

Angela Rogensues, President
Dave Dwyer, Asst. Secretary-Mayor Pro-Tem

Melody Magee, Vice President
Gary Boike
Henry Newnan

Mindy Moore, Secretary
Jonathan Lafferty

A Regular Meeting of the City Council – Tuesday, May 28, 2024 at 7:00 p.m.

Members of the audience who would like to address the City Council this evening may do so under the Audience portion and will be allowed 3 minutes to speak.

AGENDA

1 CALL TO ORDER

2 PLEDGE OF ALLEGIANCE

3 ROLL CALL

4 ADOPTION OF THE CONSENT AGENDA

5 ADOPTION OF THE AGENDA

6 CALENDAR OF PENDING MATTERS

a) Calendar

7 APPROVAL OF THE MINUTES

a) Regular Meeting Minutes-May 14, 2024

8 APPROVAL OF THE BILLS

a) General Revenue Funds

b) Water and Sewer System

c) General Fund Revenue Report - April

d) General Fund Expenditure Report - April

9 AUDIENCE PARTICIPATION– Agenda Items Only

Members of the audience who would like to address the City Council relating to agenda items this evening may do so under this Audience portion by filling out the agenda item audience form located at the right side of the stage.

10 ANNOUNCEMENTS

a) Resolution of the Warren City Council Recognizing June as Pride Month.

11 PUBLIC HEARINGS/ADMINISTRATIVE HEARINGS

a) PUBLIC HEARING: (Tabled 2/13/2024) Request to approve the demolition of a house and garage at 11309 Ford through the nuisance abatement program. CONSIDERATION AND ADOPTION OF A RESOLUTION.

- b) **PUBLIC HEARING: (Tabled 2/13/2024 & Re-tabled 4/9/2024)** Request to approve the demolition of a house and shed at 7551 Prospect through the nuisance abatement program. CONSIDERATION AND ADOPTION OF A RESOLUTION.
- c) **PUBLIC HEARING:** Request to review and confirm Special Assessment Roll No. 530, relating to 20800 Groesbeck, demolition of a commercial building, through the nuisance abatement process. CONSIDERATION AND ADOPTION OF A RESOLUTION.
- d) **PUBLIC HEARING:** Request to review and confirm Special Assessment Roll No. 531, relating to 8081 Hupp, demolition of a house and shed, through the nuisance abatement process. CONSIDERATION AND ADOPTION OF A RESOLUTION.
- e) **PUBLIC HEARING:** SUBDIVISION LOT SPLIT; located on the southeast corner of Twelve Mile Road and Adler Drive; 12980 Twelve Mile Road; Section 14; Osama Razooq (Warren C. Avey/Urban Land Consultants); PSL5230003.
- f) **PUBLIC HEARING:** Proposed Draft for the City of Warren Van Dyke Corridor Plan; An Addendum to the City of Warren Master Plan; A comprehensive initiative for a rigorous three (3) year study encompassing resident and business surveys, as well as strategic engagements with key stakeholders, including City, County, and State Officials. By February 2022, Beckett & Raeder, Inc. completed their preliminary study of the Van Dyke Corridor. This proposal is for a resolution to adopt and recommend to City Council and is an addendum to the 2021 City of Warren Master Plan; city of Warren; Tom Bommarito, DDA/TIFA Director (Beckett & Raeder, Inc., Planning Consultants).
- g) **ADMINISTRATIVE HEARING:** Request for a two (2) year extension for a previously approved request for public alley vacation; located between Globe Avenue and Nagel Street; approximately 100 ft. south of Nine Mile Road; Section 35; 12000 Nine Mile; Matt Knio; PEV210001.

12 MISCELLANEOUS CORRESPONDENCE:

- a) CONSIDERATION AND ADOPTION OF A RESOLUTION authorizing an agreement between the City of Warren and Macomb Community Action for grass and snow services, part of the CDBG Program Year Budget, in the amount of \$40,000.00, for low and moderate income senior citizens and severely disabled adults residing in the City of Warren.
- b) CONSIDERATION AND ADOPTION OF A RESOLUTION for the adoption of 2024-2025 Housing Community Development Action Plan Application for 2024-2025 CDBG, HOME, and HOPWA Funds.
- c) CONSIDERATION AND ADOPTION OF A RESOLUTION approving Grant Application under the fiscal year 2024 Law Enforcement Mental Health and Wellness Act Implementation Projects, and authorizing the Mayor and Clerk to execute memorandum of understanding relating to grant fund expenditures in the approximate amount of \$200,000.00 from the Bureau of Justice Assistance.
- d) CONSIDERATION AND ADOPTION OF A RESOLUTION granting DTE Electric Company and Overhead and Underground Easement and approving an easement agreement for properties at 7575, 7583, and 7591 Continental and Continental Parcel No. 13-28-483-022; and Granting DTE Energy on Overhead and Underground Easement and approving an easement agreement for property at 7592 Republic, Parcel No. 13-28-483-008. Additionally, request for temporary suspension of Council Rules 18.1 and 11.1 to waive reconsideration of resolutions granting the easements.

13 COUNCIL BUSINESS:

14 CORRESPONDENCE FROM THE MAYOR:

- a) **(Tabled 5.14.2024)** (Formerly 4m) Request of the City Treasurer and Public Service Director to waive the bidding process and authorize one (1) year of online service and support to BS&A Software, in the annual amount of \$48,921.00. CONSIDERATION AND ADOPTION OF A RESOLUTION.
- b) Request of the 37th District Court, Legal, City Retirement, Police and Fire Retirement, and Street lighting for an increase in budgeted revenues and appropriations of funds between line items in the amount of \$101,625.00 and an additional appropriation of funds in the amount of \$30,000.00 to provide sufficient funding in the several accounts within the General Fund Budget for the balance of the 2024 fiscal year. CONSIDERATION AND ADOPTION OF A RESOLUTION.
- c) Request of the 37th District Court for an increase in budgeted revenues and appropriations in the amount of \$71,176.00 to account for the receipt of a Michigan State Court Administrative Grant; Clean Slate Overtime reimbursement. CONSIDERATION AND ADOPTION OF A RESOLUTION.

- d) Request of Building Inspections, Public Service and Property Maintenance for a transfer of funds between line items in the amount of \$30,600.00 to provide sufficient funding in the several accounts within the General Fund Budget for the balance of the 2024 fiscal year; additional funds are necessary to cover increased utility costs and contractual obligations. CONSIDERATION AND ADOPTION OF A RESOLUTION.
- e) Request of the Police Department for an increase in budgeted revenues and appropriations in the amount of \$10,000.00 to account for the receipt of additional PA 302 Training funds received from the State of Michigan. CONSIDERATION AND ADOPTION OF A RESOLUTION.
- f) CONSIDERATION AND ADOPTION OF A RESOLUTION for a change order request for the BS&A Cloud Migration Project, from a total amount of \$855,465.00 to a total amount of \$859,505.00 (an increase of \$4,040.00) to the sole source provider, BS&A Software; SOL-W-1107.
- g) Request of the Parks and Recreation Department to furnish and install playground equipment at Licht Park from webuildfun, Inc., utilizing the Sourcewell Cooperative Contract #010521-LTS with PlayPower, Inc., in the total amount of \$597,469.90. CONSIDERATION AND ADOPTION OF A RESOLUTION.
- h) Request of the Parks and Recreation Department to furnish and install of playground equipment at Veterans Park from Playcore Wisconsin dba Game Time, utilizing the Omnia Partners Cooperative Contract #2017001134, in the total amount not to exceed \$598,749.32. CONSIDERATION AND ADOPTION OF A RESOLUTION.
- i) CONSIDERATION AND ADOPTION OF A RESOLUTION to approve Contract Modification No. 2 and Final to City Contract W-22-738, Toepfer Road Water Main Replacement (Hoover Rd. to Groesbeck Hwy.), increasing the current contract amount by \$102,824.02 resulting in a final contract amount of \$1,784,497.51; and to issue Payment No. 7 and Final in the amount of \$177,675.80 to Aielli Construction Company.
- j) CONSIDERATION AND ADOPTION OF A RESOLUTION to award bid and contract for City Project P-24-811, Miller & Denton – Pavement Reconstruction (ITB-W-0959) to the low bidder, Zuniga Cement Construction, Inc., in the total bid amount not to exceed \$1,469,722.75.
- k) Notice of appointment of David Koss to the position of Water Superintendent.
- l) Notice of appointment of Kevin Kitka to the position of Sanitation Superintendent.
- m) Request of the Human Resources Department to award bid ITB-W-1195 to furnish recruitment services for the City of Warren for a one (1) year period, with options to extend for four (4) additional one-year periods to Amy Cell, LLC, in the annual amount not to exceed \$75,000.00. CONSIDERATION AND ADOPTION OF A RESOLUTION.

15 AUDIENCE PARTICIPATION – General Topics

Members of the audience who would like to address the City Council this evening may do so under this Audience portion by filling out the general audience form located at the right side of the stage.

16 COUNCIL RESPONSE TO AUDIENCE (optional)

17 ADJOURNMENT

**MINDY MOORE
Secretary of the Council**

Any person with a disability who needs accommodation for participation in this meeting should contact the Warren City Council Office at (586) 258-2052 – 48 hours in advance of the meeting to request assistance.

CONSENT AGENDA

The following routine items are presented for City Council approval without discussion, as a single agenda item, in order to expedite the meeting. Should any Council Member wish to discuss or disapprove any item it must be dropped from the blanket motion of approval and considered as a separate item.

Item 4:

- a) Request for a closed session pursuant to Section 8(e) of Public Act 267 of 1976 in the matter of George Dedeian v City of Warren, MCCC Case No. 2024-001557-CE. Hon. Diane M. Druzinski.
- b) Request for a closed session pursuant to Section 8(e) of Public Act 267 of 1976 in the matter of Daevon Shade v City of Warren, U.S.D.C-Eastern Division, Case No. 2:24-cv-10623-MAG. Hon. Mark A. Goldsmith.
- c) Request of the 37th District Court to award bid ITB-W-1161 to furnish and deliver printed forms for the 37th District Court for a one (1) year period with the option to renew for three (3) additional one (1) year periods, in an annual amount not to exceed \$50,732.93. CONSIDERATION AND ADOPTION OF A RESOLUTION.
- d) Request of the Department of Public Works (DPW) to purchase two (2) new work trucks with dump bodies, and related equipment/services in an amount not to exceed \$173,452.00; STA-W-1244. CONSIDERATION AND ADOPTION OF A RESOLUTION.
- e) Request of the Fire Department to purchase eight (8) Motorola Handheld Portable APX Radios, accessories, activation fees and the first year's annual maintenance fees for a total amount of \$62,544.54 utilizing the State of Michigan Contract #190000001544; STA-W-1241. CONSIDERATION AND ADOPTION OF A RESOLUTION.
- f) Request of the Fire Department to extend the award for Apple Computer equipment and supplies through Apple, Inc. for the period of July 1, 2024 through June 30, 2029, in an annual amount not to exceed \$35,000.00. CONSIDERATION AND ADOPTION OF A RESOLUTION.
- g) Request of the Police Department to award the purchase of one (1) Police vehicle utilizing the State of Michigan Cooperative Vehicle Contract #071B7700177 in the amount of \$51,522.00. CONSIDERATION AND ADOPTION OF A RESOLUTION.
- h) Request of the I.S. Department to award the purchase Proofpoint Email Security Suite and Support Services from GovConnection, Inc., utilizing the Sourcewell Cooperative Contract #121923, for a three (3) year period in the total amount of \$109,038.93 (\$36,346.31 annually). CONSIDERATION AND ADOPTION OF A RESOLUTION.
- i) Request of the Parks and Recreation Department to purchase Fitness Center Equipment from Fitness Things, Inc., utilizing the Sourcewell Cooperative Contract #081120 in a total amount of \$30,999.48 when factoring in trade-in amounts. CONSIDERATION AND ADOPTION OF A RESOLUTION.
- j) Request of the Water Division to award purchase of Neptune Water Meters and Registers to the sole distributor in the State of Michigan, Ferguson Waterworks, for a one-year period, in an amount not to exceed \$275,000.00; SOL-W-1139. CONSIDERATION AND ADOPTION OF A RESOLUTION.
- k) Request of the Water Division to award of bid ITB-W-1197 for furnishing Copper Water Supply Parts for a one (1) year period, with the option to renew for one (1) additional one (1) year period, to the low-responsible and cost-effective bidder, Core & Main LP, in an annual amount not to exceed \$119,330.05. CONSIDERATION AND ADOPTION OF A RESOLUTION.
- l) Request of the Waste Water Treatment Plant to award of bid ITB-W-1194, to replace sand filter valves, to the low-responsible and cost-effective bidder, CSM Mechanical, Inc., in an amount not to exceed \$334,315.00. CONSIDERATION AND ADOPTION OF A RESOLUTION.
- m) Request of the Waste Water Treatment Plant to award of bid ITB-W-1145, for replacing the roof on buildings I and J, to the low-responsible and cost-effective bidder, Schena Roofing & Sheet Metal Company, in the total amount not to exceed \$424,500.00. CONSIDERATION AND ADOPTION OF A RESOLUTION.

- n) CONSIDERATION AND ADOPTION OF A RESOLUTION to purchase multi-functional devices (MFD), related office equipment, and corresponding Maintenance Services to Applied Innovation, through the Farmington Hills Cooperative Contract (FH-22-23-2346), for a period commencing on September 1, 2024 through January 8, 2028, in an amount not exceeding \$384,000.00.

- o) Request to vacate public alley and utility easements and the North/South 18 ft. wide public alley associated with Fire Station #1; located on the Northwest corner of Van Dyke Avenue and Continental Avenue; 23209-23211 Van Dyke Avenue; Section 28, Wilburt McAdams c/o City of Warren. PEV240001 – Set Public Hearing Date – June 25, 2024.



May 14, 2024

City Council
City of Warren

CITY ATTORNEY'S OFFICE

One City Square, Suite 400
WARREN, MI 48093
(586) 574-4671
FAX (586) 574-4530
www.cityofwarren.org

RE: GEORGE DEDEIAN v CITY OF WARREN
MCCC CASE NO. 2024-001557-CE
Hon. Diane M. Druzinski

Dear Honorable Council:

Please be advised that the above lawsuit was served on the City of Warren on or about April 19, 2024, and a copy of the same was forwarded to you by the City Clerk on that date.

Plaintiff George Dedeian filed the action to enjoin the City from demolishing the structure at 2128 Michael, Warren, Michigan 48091 (Property) and alleging a due process violation. On November 28, 2023 Council adopted the resolution to declare the vacant house and basement a nuisance and ordered its abatement. The plaintiff alleges he has lived in the house since 1984, and that he is able to repair the house. He is seeking an injunction to prevent the demolition and issuance of permits to allow him to move forward with repairs.

The lawsuit will be defended in-house by Assistant City Attorney II, Laura Sullivan.

Please place this matter on the next regular agenda to schedule a closed session regarding this litigation pursuant to section 8(e) of Public Act 267 of 1976. At the time Council convenes the closed session, a two-thirds roll call vote is required.

Respectfully submitted,

A handwritten signature in blue ink that reads "Mary Michaels".

Mary Michaels
Acting City Attorney

MM/vlt Dedeian, G 2024 - Mayor and Council ltrs ID 105170

cc: Lori M. Stone, Mayor



CITY ATTORNEY'S OFFICE

One City Square, Suite 400
WARREN, MI 48093
(586) 574-4671
FAX (586) 574-4530
www.cityofwarren.org

May 15, 2024

City Council
City of Warren

RE: DAEVON SHADE v CITY OF WARREN
U.S.D.C.-Eastern Division, Case No. 2:24-cv-10623-MAG
Hon. Mark A. Goldsmith

Dear Honorable Councilmembers:

Please be advised that the above lawsuit was served on the City of Warren on or about April 30, 2024, and a copy of the same was forwarded to you by the City Clerk on that date.

Plaintiff alleges violations of the Fourth and Fifth Amendments of the U.S. Constitution relative to the traffic stop and arrest for Resisting and Obstructing on May 23, 2023. He is seeking compensatory and emotional distress damages in the amount of \$5,000,000.00. The lawsuit has been assigned to the law firm of Secrest Wardle.

Please place this matter on the next regular agenda to schedule a closed session regarding this litigation pursuant to section 8(e) of Public Act 267 of 1976. At the time Council convenes the closed session, a two-thirds roll call vote is required.

Very truly yours,

A handwritten signature in blue ink that reads "Mary Michaels".

Mary Michaels
Acting City Attorney

MM/s105308

cc: Lori M. Stone, Mayor



CITY CONTROLLER'S OFFICE
ONE CITY SQUARE, SUITE 425
WARREN, MI 48093-5289
(586) 574-4600
FAX (586) 574-4614
www.cityofwarren.org

DATE: MAY 16, 2024
TO: MINDY MOORE, SECRETARY, WARREN CITY COUNCIL
SUBJECT: AWARD OF BID ITB-W-1161 – PRINTING OF 37TH DISTRICT COURT FORMS

The Purchasing Division concurs with the 37th District Court and recommends that City Council award bid ITB-W-1161; to Furnish and Deliver Printed Forms for the 37th District Court for a one (1) year period with the option to renew for three additional one-year periods, with mutual consent of both parties, to the low responsible and cost-effective bidder, Image Printing Company, Inc., 1902 Crooks Road, Royal Oak, MI 48073 in an annual amount not to exceed not to exceed \$50,732.93.

On Wednesday, May 15, 2024 at 1:00PM, electronic bids were publicly opened for ITB-W-1161; To Furnish and Deliver Printed forms for the 37th District Court. Bids were solicited through the BidNet® (MITN) system. Six (6) vendors responded with bids, with one not being considered due to the fact that the vendor did not attend the mandatory pre-bid meeting. These bids are summarized on the attached bid tabulation sheets submitted for your review.

If approved by your honorable body, Image Printing will be responsible for printing most of the court's envelopes and forms (see bid tabulation for listing of forms) with the exception of the following:

- Civil Forms – purchased through Target Information
- Case Management System (JIS) specific forms – purchased through MetCom
- Miscellaneous, low volume forms – purchased from various vendors

The 37th District Court is also requesting that an additional \$5,000.00 be added to the bid total of \$45,732.93. This \$5,000.00 will be used in the event a new form is needed or an existing form is needed that does not appear on the bid tabulation sheet. These forms must follow the same format as one of the forms from the ITB-W-1161 bid solicitation.

The 37th District Court has utilized Image Printing in the past and have been pleased with their work.

This award, if approved by your honorable body, shall commence on the official date of City Council approval, or July 1, 2024, whichever occurs later and have a one-year term with options to renew for three additional one-year periods, with mutual consent of both parties.

Funds are available in the following Account: 101-1136-72700.

Respectfully Submitted,



Craig Treppa
Purchasing Agent

Approved By:	Signature	Date
Budget Director:		5/20/2024
Controller:		5/20/2024
MAYOR:		5/20/2024

AS-READ BID TABULATION

City of Warren 1 City Square Warren MI 48093		BID: ITB-W-1161 Bid Opening Date: 5/15/2024 Department: 37th District Court
Product or Service: PRINTING OF FORMS		
BIDDER	GRAND TOTAL	
AVALON	DID NOT ATTEND THE MANDATORY PRE-BID MEETING, THEREFORE, NOT ACCEPTED	
DELPRINTING & DESIGN	\$83,767.00	
IMAGE PRINTING	\$45,732.93	
MAPLE PRESS PRINTING & DESIGN	\$63,519.00	
METCOM	\$75,511.30	
MODERN PRINTING SERVICES, INC.	\$99,126.00	

DEL PRINTING
AS-READ BID DETAIL

PRINTING OF
COURT FORMS

A FORM #	B DESCRIPTION	C ONE-TIME SET-UP FEE	E PRICE PER ORDER FOR 2,500	F PRICE PER ORDER FOR 5,000	G ESTIMATED ANNUAL ORDERS		H EXTENDED PRICE
					2,500	5,000	
					1	BLANK #10 ENVELOPE, NO WINDOW/NO SEAL	
2	COURT SEAL #10 ENVELOPE NO WINDOW		\$ 213.00	\$ 337.00	1	3	\$1,224.00
3	RIGHT WINDOW COURT SEAL ENVELOPE		\$ 280.00	\$ 445.00	1	5	\$2,505.00
4	LEFT WINDOW COURT SEAL ENVELOPE		\$ 225.00	\$ 360.00	1	7	\$2,745.00
5A	LEFT WINDOW COURT SEAL 6X9.5 ENVELOPE		\$ 439.00	\$ 732.00	1	7	\$5,563.00
5B	LEFT WINDOW COURT SEAL 6X9.5 ENVELOPE		\$ 439.00	\$ 732.00	1	7	\$5,563.00
6	RESTITUTION FORM		\$ 175.00	\$ 231.00	1	1	\$406.00
7	CASE NOTES		\$ 207.00	\$ 299.00	1	4	\$1,403.00
8	DISPOSITION FORM		\$ 596.00	\$ 898.00	1	4	\$4,188.00
9A	NOTICE TO APPEAR - MCC		\$ 596.00	\$ 898.00	1	1	\$1,494.00
9B	NOTICE TO APPEAR - SLF		\$ 596.00	\$ 898.00	1	1	\$1,494.00
9C	NOTICE TO APPEAR - SMB		\$ 596.00	\$ 898.00	1	1	\$1,494.00
9D	NOTICE TO APPEAR - JMC		\$ 596.00	\$ 898.00	1	1	\$1,494.00
10A	ADVICE OF RIGHTS - PAGE 1		\$ 471.00	\$ 647.00	1	3	\$2,412.00
10B	ADVICE OF RIGHTS - PAGE 2		\$ 471.00	\$ 647.00	1	3	\$2,412.00
11	WAIVER OF PRELIM EXAM		\$ 759.00	\$ 1,109.00	1	1	\$1,868.00
12	FELONY ROA		\$ 207.00	\$ 299.00	1	1	\$506.00
13	ARRAIGNMENT ATTORNEY FIRST APPEARANCE		\$ 700.00	\$ 1,018.00	1	2	\$2,736.00
14A	REQUEST FOR CAC - PAGE 1		\$ 727.00	\$ 1,034.00	1	4	\$4,863.00
14B	REQUEST FOR CAC - PAGE 2		\$ 727.00	\$ 1,034.00	1	4	\$4,863.00
15	REQUEST PAYMENT CAC		\$ 759.00	\$ 1,109.00	1	2	\$2,977.00
16	SENTENCING ORDER		\$ 596.00	\$ 898.00	1	2	\$2,392.00
17	MOTION TO AMMEND		\$ 207.00	\$ 299.00	1	2	\$805.00
18	MOTION TO AMMEND 3 PART		\$ 596.00	\$ 898.00	1	2	\$2,392.00
19A	PRETRIAL RELEASE ORDER - PAGE 1		\$ 539.00	\$ 771.00	1	2	\$2,081.00
19B	PRETRIAL RELEASE ORDER - PAGE 2		\$ 539.00	\$ 771.00	1	2	\$2,081.00
19C	PRETRIAL RELEASE ORDER - PAGE 3		\$ 539.00	\$ 771.00	1	2	\$2,081.00
19D	PRETRIAL RELEASE ORDER - PAGE 4		\$ 539.00	\$ 771.00	1	2	\$2,081.00
20	COMPLAINT MISDEMEANOR		\$ 929.00	\$ 1,260.00	1	3	\$4,709.00
21	WARRANT MISDEMEANOR - STATE		\$ 219.00	\$ 325.00	1	1	\$544.00
22	WARRANT MISDEMEANOR - CITY		\$ 207.00	\$ 299.00	1	2	\$805.00
23	LETTERHEAD		\$ 259.00	\$ 408.00	1	2	\$1,075.00
24	PSI REPORT		\$ 1,998.00	\$ 3,529.00	1	2	\$9,056.00
25	REPORT FORM		\$ 207.00	\$ 299.00	1	2	\$805.00
ESTIMATED ANNUAL PRICE:							\$83,767.00

QUESTIONS	BIDDER RESPONSE
WHAT IS YOUR TURN AROUND TIME FOR CITY ORDERS?	9-10 WORKING DAYS - OR SOONER IF NEEDED
DO YOU CHARGE FOR RUSH ORDERS?	NO
WHAT DOES YOUR COMPANY TREAT AS A RUSH ORDER (TIME FRAME)?	2-3 DAYS
IF YOU CHARGE FOR RUSH ORDERS, PLEASE DESCRIBE ALL ADDITIONAL COSTS APPLIED TO RUSH ORDERS.	NO CHARGE
HOW WILL ORDERS BE DELIVERED TO THE CITY?	DELIVERY VAN
PROVIDE THE LOCATION WHERE ORDERS WILL BE SHIPPED FROM	15435 WINDMILL DR., MACOMB, MI
DO YOU CHARGE FOR FILE CORRECTIONS?	NO
IF YOU CHARGE FOR FILE CORRECTIONS, PLEASE DESCRIBE ALL ADDITIONAL COSTS APPLIED TO FILE CORRECTIONS.	NO CHARGE
DO YOU HAVE THE ABILITY TO CORRECT .PDF OR WORD FILES?	YES
WHAT TYPES OF SOFTWARE ARE REQUIRED TO SUBMIT PRINT JOBS?	NONE
WHAT FILE FORMAT DO YOU PREFER FOR SUBMITTED PRINT JOBS?	PDF
HOW LONG DO YOU KEEP A PRINT JOB ON FILE?	10 YEARS
DO YOU CHARGE FOR DELIVERY?	NO
IF YOU CHARGE FOR DELIVERY, PLEASE DESCRIBE ALL ADDITIONAL COSTS APPLIED FOR DELIVERY FEES.	NO CHARGE
ARE THERE ANY OTHER FEES THAT WILL BE CHARGED TO THE CITY?	NO

IMAGE PRINTING CO, INC.
AS-READ BID DETAIL

FORM #	DESCRIPTION	ONE-TIME SET-UP FEE	PRICE PER ORDER FOR 2,500	PRICE PER ORDER FOR 5,000	ESTIMATED ANNUAL ORDERS		EXTENDED PRICE
					2,500	5,000	
1	BLANK #10 ENVELOPE, NO WINDOW/NO SEAL		\$ 66.00	\$ 131.98	1	2	\$329.96
2	COURT SEAL #10 ENVELOPE NO WINDOW		\$ 80.99	\$ 159.09	1	3	\$558.26
3	RIGHT WINDOW COURT SEAL ENVELOPE		\$ 101.79	\$ 198.70	1	5	\$1,095.29
4	LEFT WINDOW COURT SEAL ENVELOPE		\$ 86.17	\$ 167.00	1	7	\$1,255.17
5A	LEFT WINDOW COURT SEAL 6X9.5 ENVELOPE		\$ 178.90	\$ 348.10	1	7	\$2,615.60
5B	LEFT WINDOW COURT SEAL 6X9.5 ENVELOPE		\$ 178.90	\$ 348.10	1	7	\$2,615.60
6	RESTITUTION FORM		\$ 80.00	\$ 160.00	1	1	\$240.00
7	CASE NOTES		\$ 169.80	\$ 339.44	1	4	\$1,527.56
8	DISPOSITION FORM		\$ 173.58	\$ 347.16	1	4	\$1,562.22
9A	NOTICE TO APPEAR - MCC		\$ 287.14	\$ 531.89	1	1	\$819.03
9B	NOTICE TO APPEAR - SLF		\$ 223.81	\$ 407.81	1	1	\$631.62
9C	NOTICE TO APPEAR - SMB		\$ 223.81	\$ 407.81	1	1	\$631.62
9D	NOTICE TO APPEAR - JMC		\$ 287.14	\$ 531.89	1	1	\$819.03
10A	ADVICE OF RIGHTS - PAGE 1		\$ 155.10	\$ 310.26	1	3	\$1,085.88
10B	ADVICE OF RIGHTS - PAGE 2		\$ 155.10	\$ 310.26	1	3	\$1,085.88
11	WAIVER OF PRELIM EXAM		\$ 286.46	\$ 531.89	1	1	\$818.35
12	FELONY ROA		\$ 65.00	\$ 125.00	1	1	\$190.00
13	ARRAIGNMENT ATTORNEY FIRST APPEARANCE		\$ 277.11	\$ 554.09	1	2	\$1,385.29
14A	REQUEST FOR CAC - PAGE 1		\$ 341.13	\$ 684.27	1	4	\$3,078.21
14B	REQUEST FOR CAC - PAGE 2		\$ 341.13	\$ 684.27	1	4	\$3,078.21
15	REQUEST PAYMENT CAC		\$ 278.64	\$ 557.86	1	2	\$1,394.36
16	SENTENCING ORDER		\$ 215.67	\$ 421.12	1	2	\$1,057.91
17	MOTION TO AMMEND		\$ 65.00	\$ 130.00	1	2	\$325.00
18	MOTION TO AMMEND 3 PART		\$ 215.67	\$ 421.12	1	2	\$1,057.91
19A	PRETRIAL RELEASE ORDER - PAGE 1		\$ 215.67	\$ 421.12	1	2	\$1,057.91
19B	PRETRIAL RELEASE ORDER - PAGE 2		\$ 215.67	\$ 421.12	1	2	\$1,057.91
19C	PRETRIAL RELEASE ORDER - PAGE 3		\$ 215.67	\$ 421.12	1	2	\$1,057.91
19D	PRETRIAL RELEASE ORDER - PAGE 4		\$ 215.67	\$ 421.12	1	2	\$1,057.91
20	COMPLAINT MISDEMEANOR		\$ 510.00	\$ 1,020.00	1	3	\$3,570.00
21	WARRANT MISDEMEANOR - STATE		\$ 90.00	\$ 170.00	1	1	\$260.00
22	WARRANT MISDEMEANOR - CITY		\$ 60.00	\$ 115.00	1	2	\$290.00
23	LETTERHEAD		\$ 125.00	\$ 235.00	1	2	\$595.00
24	PSI REPORT		\$ 1,458.33	\$ 2,890.00	1	2	\$7,238.33
25	REPORT FORM		\$ 60.00	\$ 115.00	1	2	\$290.00
ESTIMATED ANNUAL PRICE:							\$45,732.93

QUESTIONS	BIDDER RESPONSE
WHAT IS YOUR TURN AROUND TIME FOR CITY ORDERS?	5 WORKING DAYS FROM PROOF APPROVAL
DO YOU CHARGE FOR RUSH ORDERS?	NO
WHAT DOES YOUR COMPANY TREAT AS A RUSH ORDER (TIME FRAME)?	2 DAY TURNAROUND
IF YOU CHARGE FOR RUSH ORDERS, PLEASE DESCRIBE ALL ADDITIONAL COSTS APPLIED TO RUSH ORDERS.	NONE APPLY
HOW WILL ORDERS BE DELIVERED TO THE CITY?	IMAGE TRUCK
PROVIDE THE LOCATION WHERE ORDERS WILL BE SHIPPED FROM	1902 CROOKS ROAD, ROYAL OAK, MICHIGAN
DO YOU CHARGE FOR FILE CORRECTIONS?	NO
IF YOU CHARGE FOR FILE CORRECTIONS, PLEASE DESCRIBE ALL ADDITIONAL COSTS APPLIED TO FILE CORRECTIONS.	NONE APPLY
DO YOU HAVE THE ABILITY TO CORRECT .PDF OR WORD FILES?	YES
WHAT TYPES OF SOFTWARE ARE REQUIRED TO SUBMIT PRINT JOBS?	PDF, TIF, WORD
WHAT FILE FORMAT DO YOU PREFER FOR SUBMITTED PRINT JOBS?	PDF
HOW LONG DO YOU KEEP A PRINT JOB ON FILE?	36 MONTHS
DO YOU CHARGE FOR DELIVERY?	NO
IF YOU CHARGE FOR DELIVERY, PLEASE DESCRIBE ALL ADDITIONAL COSTS APPLIED FOR DELIVERY FEES.	NONE APPLY
ARE THERE ANY OTHER FEES THAT WILL BE CHARGED TO THE CITY?	NONE

MAPLE PRESS PRINTING
AS-READ BID DETAIL

A FORM #	B DESCRIPTION	C ONE-TIME SET-UP FEE	E PRICE PER ORDER FOR 2,500	F PRICE PER ORDER FOR 5,000	G ESTIMATED ANNUAL ORDERS		H EXTENDED PRICE
					2,500	5,000	
					1	BLANK #10 ENVELOPE, NO WINDOW/NO SEAL	
2	COURT SEAL #10 ENVELOPE NO WINDOW		\$ 134.00	\$ 235.00	1	3	\$839.00
3	RIGHT WINDOW COURT SEAL ENVELOPE		\$ 172.00	\$ 318.00	1	5	\$1,762.00
4	LEFT WINDOW COURT SEAL ENVELOPE		\$ 141.50	\$ 250.00	1	7	\$1,891.50
5A	LEFT WINDOW COURT SEAL 6X9.5 ENVELOPE		\$ 425.00	\$ 518.00	1	7	\$4,051.00
5B	LEFT WINDOW COURT SEAL 6X9.5 ENVELOPE		\$ 425.00	\$ 518.00	1	7	\$4,051.00
6	RESTITUTION FORM		\$ 125.00	\$ 220.00	1	1	\$345.00
7	CASE NOTES		\$ 108.00	\$ 170.00	1	4	\$788.00
8	DISPOSITION FORM		\$ 498.00	\$ 715.00	1	4	\$3,358.00
9A	NOTICE TO APPEAR - MCC		\$ 498.00	\$ 715.00	1	1	\$1,213.00
9B	NOTICE TO APPEAR - SLF		\$ 498.00	\$ 715.00	1	1	\$1,213.00
9C	NOTICE TO APPEAR - SMB		\$ 498.00	\$ 715.00	1	1	\$1,213.00
9D	NOTICE TO APPEAR - JMC		\$ 498.00	\$ 715.00	1	1	\$1,213.00
10A	ADVICE OF RIGHTS - PAGE 1		\$ 370.00	\$ 499.00	1	3	\$1,867.00
10B	ADVICE OF RIGHTS - PAGE 2		\$ 370.00	\$ 499.00	1	3	\$1,867.00
11	WAIVER OF PRELIM EXAM		\$ 620.00	\$ 905.00	1	1	\$1,525.00
12	FELONY ROA		\$ 118.00	\$ 175.00	1	1	\$293.00
13	ARRAIGNMENT ATTORNEY FIRST APPEARANCE		\$ 506.00	\$ 730.00	1	2	\$1,966.00
14A	REQUEST FOR CAC - PAGE 1		\$ 615.00	\$ 907.00	1	4	\$4,243.00
14B	REQUEST FOR CAC - PAGE 2		\$ 615.00	\$ 907.00	1	4	\$4,243.00
15	REQUEST PAYMENT CAC		\$ 636.00	\$ 955.00	1	2	\$2,546.00
16	SENTENCING ORDER		\$ 498.00	\$ 715.00	1	2	\$1,928.00
17	MOTION TO AMMEND		\$ 118.00	\$ 175.00	1	2	\$468.00
18	MOTION TO AMMEND 3 PART		\$ 498.00	\$ 715.00	1	2	\$1,928.00
19A	PRETRIAL RELEASE ORDER - PAGE 1		\$ 498.00	\$ 715.00	1	2	\$1,928.00
19B	PRETRIAL RELEASE ORDER - PAGE 2		\$ 498.00	\$ 715.00	1	2	\$1,928.00
19C	PRETRIAL RELEASE ORDER - PAGE 3		\$ 498.00	\$ 715.00	1	2	\$1,928.00
19D	PRETRIAL RELEASE ORDER - PAGE 4		\$ 498.00	\$ 715.00	1	2	\$1,928.00
20	COMPLAINT MISDEMEANOR		\$ 703.00	\$ 1,000.00	1	3	\$3,703.00
21	WARRANT MISDEMEANOR - STATE		\$ 129.00	\$ 198.75	1	1	\$327.75
22	WARRANT MISDEMEANOR - CITY		\$ 108.00	\$ 173.00	1	2	\$454.00
23	LETTERHEAD		\$ 159.00	\$ 236.00	1	2	\$631.00
24	PSI REPORT		\$ 1,110.00	\$ 2,050.00	1	2	\$5,210.00
25	REPORT FORM		\$ 72.00	\$ 140.00	1	2	\$352.00
ESTIMATED ANNUAL PRICE:							\$63,519.00

QUESTIONS	BIDDER RESPONSE
WHAT IS YOUR TURN AROUND TIME FOR CITY ORDERS?	ENVELOPES & CUT SHEET FORMS 3-5 WORKDAYS, SNAPOUT FORMS 7-10 WORKDAYS
DO YOU CHARGE FOR RUSH ORDERS?	NO CHARGE FOR RUSH ORDERS
WHAT DOES YOUR COMPANY TREAT AS A RUSH ORDER (TIME FRAME)?	ENVELOPES & CUT SHEET FORMS 1-2 WORKDAYS, SNAPOUT FORMS 5-7 WORKDAYS
IF YOU CHARGE FOR RUSH ORDERS, PLEASE DESCRIBE ALL ADDITIONAL COSTS APPLIED TO RUSH ORDERS.	
HOW WILL ORDERS BE DELIVERED TO THE CITY?	DELIVERIES WILL BE MADE BY A MAPLE PRESS VAN
PROVIDE THE LOCATION WHERE ORDERS WILL BE SHIPPED FROM	NOTHING WILL BE SHIPPED
DO YOU CHARGE FOR FILE CORRECTIONS?	NO CHARGE FOR MINOR
IF YOU CHARGE FOR FILE CORRECTIONS, PLEASE DESCRIBE ALL ADDITIONAL COSTS APPLIED TO FILE CORRECTIONS.	
DO YOU HAVE THE ABILITY TO CORRECT .PDF OR WORD FILES?	YES
WHAT TYPES OF SOFTWARE ARE REQUIRED TO SUBMIT PRINT JOBS?	ADOBE
WHAT FILE FORMAT DO YOU PREFER FOR SUBMITTED PRINT JOBS?	HIGH RES PDF
HOW LONG DO YOU KEEP A PRINT JOB ON FILE?	5-10 YEARS
DO YOU CHARGE FOR DELIVERY?	NO CHARGE
IF YOU CHARGE FOR DELIVERY, PLEASE DESCRIBE ALL ADDITIONAL COSTS APPLIED FOR DELIVERY FEES.	
ARE THERE ANY OTHER FEES THAT WILL BE CHARGED TO THE CITY?	NO

METCOM, INC.
AS-READ BID DETAIL

A FORM #	B DESCRIPTION	C ONE-TIME SET-UP FEE	E PRICE PER ORDER FOR 2,500	F PRICE PER ORDER FOR 5,000	G ESTIMATED ANNUAL ORDERS		H EXTENDED PRICE
					2,500	5,000	
1	BLANK #10 ENVELOPE, NO WINDOW/NO SEAL	\$0.00	\$ 123.50	\$ 229.60	1	2	\$582.70
2	COURT SEAL #10 ENVELOPE NO WINDOW	\$0.00	\$ 143.00	\$ 268.00	1	3	\$947.00
3	RIGHT WINDOW COURT SEAL ENVELOPE	\$0.00	\$ 173.00	\$ 328.50	1	5	\$1,815.50
4	LEFT WINDOW COURT SEAL ENVELOPE	\$0.00	\$ 151.50	\$ 286.00	1	7	\$2,153.50
5A	LEFT WINDOW COURT SEAL 6X9.5 ENVELOPE	\$0.00	\$ 430.00	\$ 842.00	1	7	\$6,324.00
5B	LEFT WINDOW COURT SEAL 6X9.5 ENVELOPE	\$0.00	\$ 430.00	\$ 842.00	1	7	\$6,324.00
6	RESTITUTION FORM	\$0.00	\$ 191.50	\$ 275.00	1	1	\$466.50
7	CASE NOTES	\$0.00	\$ 132.00	\$ 270.00	1	4	\$1,212.00
8	DISPOSITION FORM	\$0.00	\$ 375.00	\$ 710.00	1	4	\$3,215.00
9A	NOTICE TO APPEAR - MCC	\$0.00	\$ 580.00	\$ 1,095.00	1	1	\$1,675.00
9B	NOTICE TO APPEAR - SLF	\$0.00	\$ 450.00	\$ 870.00	1	1	\$1,320.00
9C	NOTICE TO APPEAR - SMB	\$0.00	\$ 450.00	\$ 870.00	1	1	\$1,320.00
9D	NOTICE TO APPEAR - JMC	\$0.00	\$ 580.00	\$ 980.00	1	1	\$1,560.00
10A	ADVICE OF RIGHTS - PAGE 1	\$0.00	\$ 290.40	\$ 527.80	1	3	\$1,873.80
10B	ADVICE OF RIGHTS - PAGE 2	\$0.00	\$ 290.40	\$ 527.80	1	3	\$1,873.80
11	WAIVER OF PRELIM EXAM	\$0.00	\$ 860.00	\$ 1,250.00	1	1	\$2,110.00
12	FELONY ROA	\$0.00	\$ 189.00	\$ 355.00	1	1	\$544.00
13	ARRAIGNMENT ATTORNEY FIRST APPEARANCE	\$0.00	\$ 440.00	\$ 835.00	1	2	\$2,110.00
14A	REQUEST FOR CAC - PAGE 1	\$0.00	\$ 530.00	\$ 925.00	1	4	\$4,230.00
14B	REQUEST FOR CAC - PAGE 2	\$0.00	\$ 530.00	\$ 925.00	1	4	\$4,230.00
15	REQUEST PAYMENT CAC	\$0.00	\$ 515.40	\$ 955.80	1	2	\$2,427.00
16	SENTENCING ORDER	\$0.00	\$ 410.50	\$ 661.00	1	2	\$1,732.50
17	MOTION TO AMMEND	\$0.00	\$ 152.50	\$ 275.00	1	2	\$702.50
18	MOTION TO AMMEND 3 PART	\$0.00	\$ 160.00	\$ 285.00	1	2	\$730.00
19A	PRETRIAL RELEASE ORDER - PAGE 1	\$0.00	\$ 410.50	\$ 780.00	1	2	\$1,970.50
19B	PRETRIAL RELEASE ORDER - PAGE 2	\$0.00	\$ 410.50	\$ 780.00	1	2	\$1,970.50
19C	PRETRIAL RELEASE ORDER - PAGE 3	\$0.00	\$ 410.50	\$ 780.00	1	2	\$1,970.50
19D	PRETRIAL RELEASE ORDER - PAGE 4	\$0.00	\$ 385.00	\$ 730.00	1	2	\$1,845.00
20	COMPLAINT MISDEMEANOR	\$0.00	\$ 680.00	\$ 1,250.00	1	3	\$4,430.00
21	WARRANT MISDEMEANOR - STATE	\$0.00	\$ 171.50	\$ 315.00	1	1	\$486.50
22	WARRANT MISDEMEANOR - CITY	\$0.00	\$ 157.50	\$ 275.00	1	2	\$707.50
23	LETTERHEAD	\$0.00	\$ 414.00	\$ 764.00	1	2	\$1,942.00
24	PSI REPORT	\$0.00	\$ 2,065.00	\$ 2,990.00	1	2	\$8,045.00
25	REPORT FORM	\$0.00	\$ 149.00	\$ 258.00	1	2	\$665.00
ESTIMATED ANNUAL PRICE:							\$75,511.30

QUESTIONS	BIDDER RESPONSE
WHAT IS YOUR TURN AROUND TIME FOR CITY ORDERS?	ONE (1) - TWELVE (12) PRODUCTION DAYS
DO YOU CHARGE FOR RUSH ORDERS?	NO
WHAT DOES YOUR COMPANY TREAT AS A RUSH ORDER (TIME FRAME)?	INSTEAD OF CLASSIFYING ORDERS INTO RUSH AND NON-RUSH, WE PRIORITIZE ORDERS THAT INCLUDE A REQUIRED IN-HANDS DATE.
IF YOU CHARGE FOR RUSH ORDERS, PLEASE DESCRIBE ALL ADDITIONAL COSTS APPLIED TO RUSH ORDERS.	N/A
HOW WILL ORDERS BE DELIVERED TO THE CITY?	VIA UPS, FEDEX & LOCAL VEHICLE
PROVIDE THE LOCATION WHERE ORDERS WILL BE SHIPPED FROM	STAIN CLAIR SHORES, MICHIGAN; TROY, MICHIGAN; CANTON, MICHIGAN; TOLEDO OHIO; FORT WAYNE, INDIANA
DO YOU CHARGE FOR FILE CORRECTIONS?	NO
IF YOU CHARGE FOR FILE CORRECTIONS, PLEASE DESCRIBE ALL ADDITIONAL COSTS APPLIED TO FILE CORRECTIONS.	N/A
DO YOU HAVE THE ABILITY TO CORRECT .PDF OR WORD FILES?	YES
WHAT TYPES OF SOFTWARE ARE REQUIRED TO SUBMIT PRINT JOBS?	OUR ERP WILL ACCEPT ORDERS FROM ALL SOFTWARE TYPES
WHAT FILE FORMAT DO YOU PREFER FOR SUBMITTED PRINT JOBS?	PDF; EPS
HOW LONG DO YOU KEEP A PRINT JOB ON FILE?	DIGITAL CLOUD STORAGE ALLOWS FOR UNLIMITED ACCESS TO ORDER HISTORY
DO YOU CHARGE FOR DELIVERY?	NO
IF YOU CHARGE FOR DELIVERY, PLEASE DESCRIBE ALL ADDITIONAL COSTS APPLIED FOR DELIVERY FEES.	N/A
ARE THERE ANY OTHER FEES THAT WILL BE CHARGED TO THE CITY?	NO

MODERN PRINTING SERVICES, INC.
AS-READ BID DETAIL

A FORM #	B DESCRIPTION	C ONE-TIME SET-UP FEE	E PRICE PER ORDER FOR 2,500	F PRICE PER ORDER FOR 5,000	G ESTIMATED ANNUAL ORDERS		H EXTENDED PRICE
					2,500	5,000	
					1	BLANK #10 ENVELOPE, NO WINDOW/NO SEAL	
2	COURT SEAL #10 ENVELOPE NO WINDOW		\$ 160.00	\$ 280.00	1	3	\$1,000.00
3	RIGHT WINDOW COURT SEAL ENVELOPE		\$ 198.00	\$ 365.00	1	5	\$2,023.00
4	LEFT WINDOW COURT SEAL ENVELOPE		\$ 175.00	\$ 310.00	1	7	\$2,345.00
5A	LEFT WINDOW COURT SEAL 6X9.5 ENVELOPE		\$ 330.00	\$ 625.00	1	7	\$4,705.00
5B	LEFT WINDOW COURT SEAL 6X9.5 ENVELOPE		\$ 330.00	\$ 625.00	1	7	\$4,705.00
6	RESTITUTION FORM		\$ 118.00	\$ 183.00	1	1	\$301.00
7	CASE NOTES		\$ 130.00	\$ 220.00	1	4	\$1,010.00
8	DISPOSITION FORM		\$ 615.00	\$ 1,150.00	1	4	\$5,215.00
9A	NOTICE TO APPEAR - MCC		\$ 615.00	\$ 1,150.00	1	1	\$1,765.00
9B	NOTICE TO APPEAR - SLF		\$ 615.00	\$ 1,150.00	1	1	\$1,765.00
9C	NOTICE TO APPEAR - SMB		\$ 615.00	\$ 1,150.00	1	1	\$1,765.00
9D	NOTICE TO APPEAR - JMC		\$ 615.00	\$ 1,150.00	1	1	\$1,765.00
10A	ADVICE OF RIGHTS - PAGE 1		\$ 374.00	\$ 726.00	1	3	\$2,552.00
10B	ADVICE OF RIGHTS - PAGE 2		\$ 374.00	\$ 726.00	1	3	\$2,552.00
11	WAIVER OF PRELIM EXAM		\$ 780.00	\$ 1,535.00	1	1	\$2,315.00
12	FELONY ROA		\$ 130.00	\$ 220.00	1	1	\$350.00
13	ARRAIGNMENT ATTORNEY FIRST APPEARANCE		\$ 615.00	\$ 1,150.00	1	2	\$2,915.00
14A	REQUEST FOR CAC - PAGE 1		\$ 1,006.00	\$ 1,434.00	1	4	\$6,742.00
14B	REQUEST FOR CAC - PAGE 2		\$ 1,006.00	\$ 1,434.00	1	4	\$6,742.00
15	REQUEST PAYMENT CAC		\$ 780.00	\$ 1,535.00	1	2	\$3,850.00
16	SENTENCING ORDER		\$ 615.00	\$ 1,150.00	1	2	\$2,915.00
17	MOTION TO AMMEND		\$ 130.00	\$ 220.00	1	2	\$570.00
18	MOTION TO AMMEND 3 PART		\$ 615.00	\$ 1,150.00	1	2	\$2,915.00
19A	PRETRIAL RELEASE ORDER - PAGE 1		\$ 615.00	\$ 1,150.00	1	2	\$2,915.00
19B	PRETRIAL RELEASE ORDER - PAGE 2		\$ 615.00	\$ 1,150.00	1	2	\$2,915.00
19C	PRETRIAL RELEASE ORDER - PAGE 3		\$ 615.00	\$ 1,150.00	1	2	\$2,915.00
19D	PRETRIAL RELEASE ORDER - PAGE 4		\$ 615.00	\$ 1,150.00	1	2	\$2,915.00
20	COMPLAINT MISDEMEANOR		\$ 1,363.00	\$ 1,990.00	1	3	\$7,333.00
21	WARRANT MISDEMEANOR - STATE		\$ 159.00	\$ 267.00	1	1	\$426.00
22	WARRANT MISDEMEANOR - CITY		\$ 130.00	\$ 220.00	1	2	\$570.00
23	LETTERHEAD		\$ 411.00	\$ 707.00	1	2	\$1,825.00
24	PSI REPORT		\$ 2,700.00	\$ 5,400.00	1	2	\$13,500.00
25	REPORT FORM		\$ 130.00	\$ 220.00	1	2	\$570.00
ESTIMATED ANNUAL PRICE:							\$99,126.00

QUESTIONS	BIDDER RESPONSE
WHAT IS YOUR TURN AROUND TIME FOR CITY ORDERS?	MOST ITEMS ARE 5-7 WORK DAYS. SOME ITEMS WILL TAKE LONGER.
DO YOU CHARGE FOR RUSH ORDERS?	NO
WHAT DOES YOUR COMPANY TREAT AS A RUSH ORDER (TIME FRAME)?	N/A
IF YOU CHARGE FOR RUSH ORDERS, PLEASE DESCRIBE ALL ADDITIONAL COSTS APPLIED TO RUSH ORDERS.	N/A
HOW WILL ORDERS BE DELIVERED TO THE CITY?	OUR TRUCK OR UPS
PROVIDE THE LOCATION WHERE ORDERS WILL BE SHIPPED FROM	8850 DIXIE HWY., FAIR HAVEN, MI 48023
DO YOU CHARGE FOR FILE CORRECTIONS?	NO
IF YOU CHARGE FOR FILE CORRECTIONS, PLEASE DESCRIBE ALL ADDITIONAL COSTS APPLIED TO FILE CORRECTIONS.	N/A
DO YOU HAVE THE ABILITY TO CORRECT .PDF OR WORD FILES?	YES
WHAT TYPES OF SOFTWARE ARE REQUIRED TO SUBMIT PRINT JOBS?	N/A
WHAT FILE FORMAT DO YOU PREFER FOR SUBMITTED PRINT JOBS?	PDF
HOW LONG DO YOU KEEP A PRINT JOB ON FILE?	NO LIMIT
DO YOU CHARGE FOR DELIVERY?	NOT FOR CONTRACT WORK
IF YOU CHARGE FOR DELIVERY, PLEASE DESCRIBE ALL ADDITIONAL COSTS APPLIED FOR DELIVERY FEES.	N/A
ARE THERE ANY OTHER FEES THAT WILL BE CHARGED TO THE CITY?	NO

Modern Printing Services, Inc. bid the following exceptions: Items 11 and 15 will be printed on white-yellow-pink-gold, instead of white-yellow-pink-blue.

State of Michigan

37th DISTRICT COURT

JOHN M. CHMURA
CHIEF JUDGE

SUZANNE L. FAUNCE
CHIEF JUDGE PRO TEM

MICHAEL C. CHUPA
DISTRICT JUDGE

STEVEN M. BIEDA
DISTRICT JUDGE



ANNETTE GATTARI-ROSS
COURT ADMINISTRATOR/MAGISTRATE

Warren Division
8300 Common Road
Warren, Michigan 48093-2380
Phone: (586)574-4900

Center Line Division
7070 East Ten Mile Road
Center Line, Michigan 48015-1100
Phone: (586)757-8333

May 16, 2024

Mr. Craig Treppa
Purchasing Agent, City of Warren
One City Square, Suite 425
Warren, MI 48093

RE: ITB-W-1161 PRINTING OF 37TH DISTRICT COURT FORMS

Dear Mr. Treppa:

The Court's recommendation is to award this contract to Image Printing Co Inc. for court form printing services at an estimated annual price not to exceed \$50,732.93 (See bid tabulation for a summary and specific cost breakdown). The court is requesting an additional \$5,000 over the bid calculation to account for any additional forms that may arise during the contracted period.

The bid as presented will provide the printing of envelopes and forms utilized at the court for all purposes, excluding civil forms, which are purchased through Target Information, and case management system (JIS) specific forms, which will be purchased through Metcom. The court has awarded a bid in the past to Image Printing, for the printing of our yearly Case Binder Files, and they have provided quality products and excellent customer service.

Term dates for this bid are as follows: 7/1/24-6/30/25.

Funds are available in the Court's Office Supply fund, account number 101-1136-72700.
If you have any questions, please contact me at your earliest convenience.

Respectfully submitted,

A handwritten signature in cursive script that reads "Annette Gattari-Ross".

Annette Gattari-Ross
Court Administrator/Magistrate
37th District Court

AGR/kmb
Attachment
C: file

RESOLUTION

Document No: ITB-W-1161

Product or Service: Printing of 37th District Court Forms

Requesting Department: 37th District Court

At a Regular Meeting of the City Council of the City of Warren, County of Macomb, Michigan, held on _____ 2024, at 7 p.m. Local Time, in the Council Chamber at the Warren Community Center Auditorium, 5460 Arden, Warren, Michigan.

PRESENT: Councilmembers: _____

ABSENT: Councilmembers: _____

The following preamble and resolution were offered by Councilmember _____ and supported by Councilmember _____.

Electronic bids were accepted, publicly opened and read on 5-15-24 at 1 p.m.

The following bids have been received by City Council:

BIDDERS: AMOUNT:

Please see attached bid tabulation

The bid of Image Printing Company, Inc., 1902 Crooks Road, Royal Oak, MI 48073 has been determined to be the low responsible and cost-effective bid for award.

Funds are available in account numbers: 101-1136-72700.

IT IS RESOLVED, that the bid of Image Printing Company, Inc. is hereby accepted by City Council for a one-year period, with options to renew for three additional

one-year periods in an annual amount not to exceed \$50,732.93, commencing on the official date of City Council approval, or July 1, 2024 whichever occurs later.

IT IS FURTHER RESOLVED, that the 37th District Court has an additional \$5,000.00 (included in the \$50,732.93) to be used for new forms that are needed or existing forms that do not appear on the bid tabulation sheet. These forms must follow the same format as one of the forms from the ITB-W-1161 bid solicitation.

IT IS FURTHER RESOLVED, that the Purchasing Agent and/or Mayor and City Clerk are authorized to execute any such documents that are necessary for this approval consistent with the terms of the:

- Bid document
- Contract
- Resolution

and in such form that meets with the satisfaction of the City Attorney if review is required.

AYES: Councilmembers: _____

NAYS: Councilmembers: _____

RESOLUTION DECLARED ADOPTED this ____ day of _____, 2024.

Mindy Moore
Secretary of the Council



DATE: MAY 17, 2024
 TO: MINDY MOORE, SECRETARY OF WARREN CITY COUNCIL
 SUBJECT: AWARD RECOMMENDATION TO PURCHASE TWO (2) NEW WORK TRUCKS WITH DUMP BODIES; STA-W-1244.

The Purchasing Division concurs with the Department of Public Works (DPW) and recommends that City Council approve an award to the vendors listed below, at the prices indicated, for the purpose of purchasing two (2) Work Trucks, and related equipment/services in an amount not to exceed \$173,452.00.

If the City Council approves these purchases, payment shall be authorized to be made immediately upon successful completion from the recommended vendors.

PRICING SUMMARY			
VENDOR	DESCRIPTION	UNIT PRICE	EXTENDED PRICE (Quantity of 2)
Todd Wenzel Buick-GMC 35100 Ford Road Westland, MI 48185	Two (2) 2024 Chevrolet Silverado 3500HD 4x4 Reg Cab/Chassis	\$50,628.00	\$101,256.00
Truck and Trailer Specialties 6726 Hanna Lake Dutton, MI 49316	Two (2) Crysteel 9' S-Tipper Dump Bodies	\$ 36,098.00	\$ 72,196.00
GRAND TOTAL:			\$173,452.00

The City is seeking approval from your honorable body to purchase two (2) 2024 Chevrolet Silverado Cab/Chassis utilizing the State of Michigan MiDeal Vehicle Contract #071B7700178 (attached).

On December 1, 2023, 2020 Rochester Hills City Council approved the extension of award RFP-RH-20-023 through September 30, 2025, Dump Body and Related Equipment to Truck & Trailer Specialties, Inc.

The City is also seeking approval to purchase two (2) Crysteel 9' S-Tipper Dump Bodies, and related equipment/services utilizing the above referenced Rochester Hills Cooperative Contract with Truck & Trailer Specialties # RH-20-023 (attached).

If approved by your honorable body, these work trucks will be utilized by the DPW as everyday work trucks to complete various tasks throughout the City.

Funds are available in the DPW Vehicle & Equipment Account: 101-1442-98103.

Respectfully Submitted,



Craig Treppa
Purchasing Agent

Approved By:	Signature	Date
Budget Director:		5/20/2024
Controller:		5/22/2024
MAYOR:		5/22/24



STATE OF MICHIGAN
CENTRAL PROCUREMENT SERVICES
 Department of Technology, Management, and Budget
 320 S. WALNUT ST., LANSING, MICHIGAN 48933
 P.O. BOX 30026 LANSING, MICHIGAN 48909

CONTRACT CHANGE NOTICE

Change Notice Number **6**
 to
 Contract Number **071B7700178**

CONTRACTOR	TODD WENZEL CHEVROLET
	3156 Highland Dr. , Po Box 310
	Hudsonville, MI 49426
	Albert Li
	734-721-1144 4265
	ali@toddwenzel.com
	CV0127388

STATE	Various	SW
	Yvon Dufour	DTMB
	(517) 249-0455	
	dufoury@michigan.gov	

CONTRACT SUMMARY			
VEHICLES - PATROL, PASSENGER, TRUCKS AND VANS			
August 1, 2017	November 30, 2022	1 - 2 Year	November 30, 2024
<input type="checkbox"/> P-Card <input type="checkbox"/> PRC <input type="checkbox"/> Other <input checked="" type="checkbox"/> Yes <input type="checkbox"/> No			
DESCRIPTION OF CHANGE NOTICE			
<input type="checkbox"/>		<input type="checkbox"/>	November 30, 2024
\$250,001.00	\$0.00	\$250,001.00	
DESCRIPTION			
Effective 11/13/2023, pricing on this contract is hereby updated, per revised Schedule D - Pricing (attached). All other terms, conditions, specifications and pricing remain the same. Per contractor proposal, and DTMB Procurement approval.			



Todd Wenzel Buick-GMC and Chevrolet

Albert Li | (734) 713-1065 | ali@toddwenzel.com

City of Warren DPW

Prepared For: Scott Raedel

(586) 759-9292

sraedel@cityofwarren.org

Vehicle: [Fleet] 2024 Chevrolet Silverado 3500HD CC (CK31003) 4WD Reg Cab 146" WB, 60" CA
Work Truck

TODD WENZEL CHEVROLET

3156 Highland Dr, PO Box 310

Hudsonville, MI 49426

State of Michigan MiDeal Contract # 071B7700178

MiDeal Spec # 0111-4WDM

City of Warren (DPW) Pricing

(MiDeal Pricing)

2024 Chevrolet Silverado 3500HD Reg Cab 4x4 Chassis

14000# GVWR Gas V8 / Allison Trans Reg Cab 4x4 60"CA

2024 Chevrolet Silverado 3500HD Reg 4x4 Chassis \$ 44,377.00

Prices Quoted are for a MiDeal Dealer Incoming Order.
FOB Warren, MI



Todd Wenzel Buick-GMC and Chevrolet

Albert Li | (734) 713-1065 | ali@toddwenzel.com

Vehicle: [Fleet] 2024 Chevrolet Silverado 3500HD CC (CK31003) 4WD Reg Cab 146" WB, 60" CA Work Truck (✔ Complete)

Price Summary

PRICE SUMMARY		MSRP
Base Price		\$47,500.00
Total Options		\$1,133.00
Vehicle Subtotal		\$48,633.00
Destination Charge		\$1,995.00
Grand Total		\$50,628.00

This document contains information considered Confidential between GM and its Clients uniquely. The information provided is not intended for public disclosure. Prices, specifications, and availability are subject to change without notice, and do not include certain fees, taxes and charges that may be required by law or vary by manufacturer or region. Performance figures are guidelines only, and actual performance may vary. Photos may not represent actual vehicles or exact configurations. Content based on report preparer's input is subject to the accuracy of the input provided.

Data Version: 22394, Data Updated: May 6, 2024 6:41:00 PM PDT.



Todd Wenzel Buick-GMC and Chevrolet

Albert Li | (734) 713-1065 | ali@toddwenzel.com

Vehicle: [Fleet] 2024 Chevrolet Silverado 3500HD CC (CK31003) 4WD Reg Cab 146" WB, 60" CA Work Truck (✔ Complete)

Selected Model and Options

MODEL

CODE	MODEL
CK31003	2024 Chevrolet Silverado 3500HD CC 4WD Reg Cab 146" WB, 60" CA Work Truck

COLORS

CODE	DESCRIPTION
01U	Special Exterior Color.

OPTIONS

CODE	DESCRIPTION
FE9	Emissions, Federal requirements
L8T	Engine, 6.6L V8 with Direct Injection and Variable Valve Timing, gasoline
MKM	Transmission, Allison 10-Speed automatic
GT4	Rear axle, 3.73 ratio
1WT	Work Truck Preferred Equipment Group
PYW	Wheels, 17" (43.2 cm) painted steel
QZT	Tires, LT235/80R17E all-terrain, blackwall
9L3	Spare tire delete
AZ3	Seats, front 40/20/40 split-bench
H1T	Jet Black, Cloth seat trim
IOR	Audio system, Chevrolet Infotainment 3 system, 7" diagonal HD color touchscreen, AM/FM stereo
ZLQ	WT Fleet Convenience Package
VYU	Snow Plow Prep Package
K4Z	Battery, auxiliary, 700 cold-cranking amps/70 Amp-hr
KW5	Alternator, 220 amps
NZZ	Skid Plates
V46	Bumper, front chrome
9L7	Upfitter switch kit, (5)
K34	Cruise control, electronic
R9L	Deleted 3 Years of Remote Access
01U	Special Exterior Color.

This document contains information considered Confidential between GM and its Clients uniquely. The information provided is not intended for public disclosure. Prices, specifications, and availability are subject to change without notice, and do not include certain fees, taxes and charges that may be required by law or vary by manufacturer or region. Performance figures are guidelines only, and actual performance may vary. Photos may not represent actual vehicles or exact configurations. Content based on report preparer's input is subject to the accuracy of the input provided.

Data Version: 22394. Data Updated: May 6, 2024 6:41:00 PM PDT.



Todd Wenzel Buick-GMC and Chevrolet

Albert LI | (734) 713-1065 | ali@toddwenzel.com

Vehicle: [Fleet] 2024 Chevrolet Silverado 3500HD CC (CK31003) 4WD Reg Cab 146" WB, 60" CA Work Truck (✔ Complete)

OPTIONS	
CODE	DESCRIPTION
9W3	Paints, solid, Wheatland Yellow.
TGK	Special Paint.
5N5	Rear Camera Kit.
Options Total	

This document contains information considered Confidential between GM and its Clients uniquely. The information provided is not intended for public disclosure. Prices, specifications, and availability are subject to change without notice, and do not include certain fees, taxes and charges that may be required by law or vary by manufacturer or region. Performance figures are guidelines only, and actual performance may vary. Photos may not represent actual vehicles or exact configurations. Content based on report preparer's input is subject to the accuracy of the input provided.
Data Version: 22384. Data Updated: May 6, 2024 6:41:00 PM PDT.



Todd Wenzel Buick-GMC and Chevrolet

Albert Li | (734) 713-1065 | ali@toddwenzel.com

Vehicle: [Fleet] 2024 Chevrolet Silverado 3500HD CC (CK31003) 4WD Reg Cab 146" WB, 60" CA Work Truck (✔ Complete)

Standard Equipment

Mechanical

Engine, 6.6L V8 with Direct Injection and Variable Valve Timing, gasoline (401 hp [299 kW] @ 5200 rpm, 464 lb-ft of torque [629 N-m] @ 4000 rpm) (STD)

Transmission, Allison 10-Speed automatic (STD)

Rear axle, 3.73 ratio (Requires (L8T) 6.6L V8 gas engine. Not available with (L5P) Duramax 6.6L Turbo-Diesel V8 engine.)

Auto-locking rear differential

Air filter, heavy-duty

Air filtration monitoring

Transfer case, two-speed, electronic shift with push button controls (Requires 4WD models.)

Four wheel drive

Cooling, external engine oil cooler

Cooling, auxiliary external transmission oil cooler

Battery, heavy-duty 720 cold-cranking amps/80 Amp-hr, maintenance-free with rundown protection and retained accessory power (Included and only available with (L8T) 6.6L V8 gas engine.)

Alternator, 170 amps (Requires (L8T) 6.6L V8 gas engine.)

Trailer brake controller, integrated

Recovery hooks, front, frame-mounted, Black

Body, Chassis Cab

Frame, fully-boxed, hydroformed front section and an open "C" rear section

GVWR, 14,000 lbs. (6350 kg)

Suspension Package

Steering, Recirculating Ball with smart flow power steering system

Brakes, 4-wheel antilock, 4-wheel disc with DURALIFE rotors

Fuel tank, front and rear, 63.5 gallon

Capped Fuel Fill

Exterior

Wheels, 17" (43.2 cm) painted steel

Tires, LT235/80R17E all-terrain, blackwall

Dual Rear Wheels

Wheel trim, painted center caps

This document contains information considered Confidential between GM and its Clients uniquely. The information provided is not intended for public disclosure. Prices, specifications, and availability are subject to change without notice, and do not include certain fees, taxes and charges that may be required by law or vary by manufacturer or region. Performance figures are guidelines only, and actual performance may vary. Photos may not represent actual vehicles or exact configurations. Content based on report preparer's input is subject to the accuracy of the input provided.

Data Version: 22394. Data Updated: May 6, 2024 6:41:00 PM PDT.



Todd Wenzel Buick-GMC and Chevrolet

Albert LI | (734) 713-1065 | ali@toddwenzel.com

Vehicle: [Fleet] 2024 Chevrolet Silverado 3500HD CC (CK31003) 4WD Reg Cab 146" WB, 60" CA Work Truck (✔ Complete)

Exterior

Bumpers, front, Black

Bumper, rear, delete

Moldings, beltline, Black

Grille (Front grille bar with "CHEVROLET" molded in Black, includes Black mesh Inserts with small Gold bowtie emblem.)

Headlamps, halogen reflector with halogen Daytime Running Lamps

IntelliBeam, automatic high beam on/off

Lamps, Smoked Amber roof marker, (LED)

Lamps, cargo area, cab mounted integrated with center high mount stop lamp with switch in bank on left side of steering wheel

Mirrors, outside power-adjustable vertical trailing with heated upper glass, lower convex mirrors, integrated turn signals, manual folding/extending (extends 3.31" [84.25mm]) (Standard on Regular Cab models. Included and only available with (PCV) WT Convenience Package or (ZLQ) WT Fleet Convenience Package.)

Mirror caps, Black

Glass, solar absorbing, tinted

Door handles, Black grained

Entertainment

Audio system, Chevrolet Infotainment 3 system, 7" diagonal HD color touchscreen, AM/FM stereo Bluetooth audio streaming for 2 active devices, voice command pass-through to phone, Wireless Apple CarPlay and Wireless Android Auto compatibility (STD)

Audio system feature, 2-speakers (Requires Regular Cab model.)

Bluetooth for phone, connectivity to vehicle infotainment system

Wi-Fi Hotspot capable (Terms and limitations apply. See onstar.com or dealer for details.)

Interior

Seats, front 40/20/40 split-bench with covered armrest storage and under-seat storage (lockable) (STD)

Seat adjuster, driver 4-way manual

Seat adjuster, passenger 4-way manual

Vinyl seat trim

Floor covering, rubberized-vinyl

Steering wheel, urethane

Instrument cluster 6-gauge cluster featuring speedometer, fuel level, engine temperature, tachometer, voltage and oil pressure

Compass, located in instrument cluster

This document contains information considered Confidential between GM and its Clients uniquely. The information provided is not intended for public disclosure. Prices, specifications, and availability are subject to change without notice, and do not include certain fees, taxes and charges that may be required by law or vary by manufacturer or region. Performance figures are guidelines only, and actual performance may vary. Photos may not represent actual vehicles or exact configurations. Content based on report preparer's input is subject to the accuracy of the input provided.

Data Version: 22394. Data Updated: May 6, 2024 6:41:00 PM PDT.



Todd Wenzel Buick-GMC and Chevrolet

Albert Li | (734) 713-1065 | ali@toddwenzel.com

Vehicle: [Fleet] 2024 Chevrolet Silverado 3500HD CC (CK31003) 4WD Reg Cab 146" WB, 60" CA Work Truck (✔ Complete)

Interior

Driver Information Center, 3.5" diagonal monochromatic display

Exterior Temperature Display located in radio display

Brake lining wear indicator

Window, power front, drivers express up/down

Window, power front, passenger express down

Door locks, power

Remote Keyless Entry, with 2 transmitters

Power outlet, front auxillary, 12-volt

USB Ports, 2, Charge/Data ports located on instrument panel

Air conditioning, single-zone

Mirror, inside rearview, manual tilt

Assist handles front A-pillar mounted for driver and passenger

Chevrolet Connected Access capable (Subject to terms. See onstar.com or dealer for details.)

Back-up alarm calibration. This calibration will allow installation of an aftermarket back-up alarm by disabling rear perimeter lighting (Not available with (BS3) Back-up alarm.)

Safety-Mechanical

StabiliTrak, stability control system with Proactive Roll Avoidance and traction control, includes electronic trailer sway control and hill start assist

Automatic Emergency Braking

Front Pedestrian Braking

Safety-Exterior

Daytime Running Lamps with automatic exterior lamp control

Safety-Interior

Airbags Dual-stage frontal airbags for driver and front outboard passenger; Seat-mounted side impact airbags for driver and front outboard passenger; Head-curtain airbags for front and rear outboard seating positions; Includes front outboard Passenger Sensing System for frontal outboard passenger airbag (Always use seat belts and child restraints. Children are safer when properly secured in a rear seat in the appropriate child restraint. See the Owner's Manual for more information.)

Following Distance Indicator

Forward Collision Alert

Tire Pressure Monitoring System with Tire Fill Alert (does not apply to spare tire)

This document contains information considered Confidential between GM and its Clients uniquely. The information provided is not intended for public disclosure. Prices, specifications, and availability are subject to change without notice, and do not include certain fees, taxes and charges that may be required by law or vary by manufacturer or region. Performance figures are guidelines only, and actual performance may vary. Photos may not represent actual vehicles or exact configurations. Content based on report preparer's input is subject to the accuracy of the input provided.

Data Version: 22394. Date Updated: May 6, 2024 6:41:00 PM PDT.



Todd Wenzel Buick-GMC and Chevrolet

Albert Li | (734) 713-1065 | all@toddwenzel.com

Vehicle: [Fleet] 2024 Chevrolet Silverado 3500HD CC (CK31003) 4WD Reg Cab 146" WB, 60" CA Work Truck (✔ Complete)

Safety-Interior

Teen Driver a configurable feature that lets you activate customizable vehicle settings associated with a key fob, to help encourage safe driving behavior. It can limit certain available vehicle features, and it prevents certain safety systems from being turned off. An in-vehicle report card gives you information on driving habits and helps you to continue to coach your new driver

Buckle to Drive prevents vehicle from being shifted out of Park until driver seat belt is fastened; times out after 20 seconds and encourages seat belt use

OnStar and Chevrolet connected services capable (Terms and limitations apply. See onstar.com or dealer for details.)

3 Years of Remote Access The Remote Access Plan gives you simplified remote control of your properly equipped vehicle and unlocks a variety of great features in your myChevrolet mobile app. See dealer for details. (Remote Access Plan does not include emergency or security services. See onstar.com for details and limitations. Available on select Apple and Android devices. Service availability, features and functionality vary by vehicle, device, and the plan you are enrolled in. Terms apply. Device data connection required.)

WARRANTY

Basic Years: 3

Basic Miles/km: 36,000

Drivetrain Years: 5

Drivetrain Miles/km: 60,000

Drivetrain Note: 3.0L & 6.0L Duramax® Turbo-Diesel engines, and certain commercial, government, and qualified fleet vehicles: 5 years/100,000 miles

Corrosion Years (Rust-Through): 6

Corrosion Years: 3

Corrosion Miles/km (Rust-Through): 100,000

Corrosion Miles/km: 36,000

Roadside Assistance Years: 5

Roadside Assistance Miles/km: 60,000

Roadside Assistance Note: 3.0L & 6.0L Duramax® Turbo-Diesel engines, and certain commercial, government, and qualified fleet vehicles: 5 years/100,000 miles

Maintenance Note: First Visit: 12 Months/12,000 Miles

This document contains information considered Confidential between GM and its Clients uniquely. The information provided is not intended for public disclosure. Prices, specifications, and availability are subject to change without notice, and do not include certain fees, taxes and charges that may be required by law or vary by manufacturer or region. Performance figures are guidelines only, and actual performance may vary. Photos may not represent actual vehicles or exact configurations. Content based on report preparer's input is subject to the accuracy of the input provided.

Data Version: 22394. Data Updated: May 6, 2024 6:41:00 PM PDT.



innovative by nature

Bryan K. Barnett
Mayor

CONTRACT AMENDMENT

City Council

City of Rochester Hills
Purchasing Division
1000 Rochester Hills Drive
Rochester Hills, MI 48309

Ravi Yalamanchi
District 1

Re: RFP-RH-20-023

Adam Kochenderfer
District 2

Contract Amendment 1 - Truck and Trailer Specialties. - Truck Body

Greg Hooper
District 3

This contract is amended as follows:

Nathan Klomp
District 4

Single and Tandem Axle Dump Trucks, Parts, and Related Equipment/Services

James Rosen
At-Large

This is a Contract Amendment, dated this 1st day of December, 2023, to the Single and Tandem Axle Dump Trucks, Parts, and Related Services between Truck and Trailer Specialties ("Contractor"), a Michigan corporation, whose address is 6726 Hanna Lake Road, S.E., Dutton, MI 49316, and the City of Rochester Hills ("City") a Michigan municipal corporation, whose address is 1000 Rochester Hills Drive, Rochester Hills, Michigan 48309, dated September 25th, 2020.

Mark Hadel
At-Large

1. The parties agree that by execution of this Addendum that the contract's two year renewal option of the contract has been exercised and the new term of the contract will expire as of September 30, 2025.

Michael Webber
At-Large

2. All other provisions of the contract shall remain the same

In witness whereof, the Parties hereto have executed this Addendum the day and year written above.

Contractor hereby acknowledges receipt of and understanding of the above amendment.

Daniel J. Bouwman
Daniel J. Bouwman, President
Truck and Trailer Specialties

Daniel J. Bouwman Pres.
Printed name and title
Truck & Trailer Specialties, Inc.
Company name

The above referenced contract amendment is hereby executed this

1st day of December 2023 at
Rochester Hills, Michigan.

Bryan Barnett
Bryan Barnett
Mayor

TRUCK & TRAILER Specialties, Inc.

900 Grand Oaks Drive | Howell, MI 48843 | www.ttspec.com | ph: (517) 552-3855 | fx: (517) 552-3666

May 17, 2024

City of Warren
12821 Stephens, Warren, MI 48089
Attn: Scott Raedel, ph: (586) 759-9261
HQ0003638

Equipment Quotation

The following pricing will be based on City of Rochester Hills RFP-RH-20-023 contract awarded September 2020

Chassis: 2024 GMC3500 Sierra, Reg Cab, DRW, 4x4, 60" CA, gas engine, auto trans, upfitter switches, camera, dual fuel tanks, vinyl floor & plow prep

Install Crysteel 9' S-Tipper Dump Body including the following:

108" length, 87" inside width, 96" outside width
Front: 10-gauge 201 stainless steel, 40" high
Sides: 10-gauge 201 stainless steel, rigid sides 14" high
Tailgate: 10-gauge 201 stainless steel, 3-panel, 22" high with quick-drop release handle
Capacity: 3-4 cubic yards
Floor: 3/16" AR450 floor
Understructure: Western-style crossmemberless
¼ straight integral full-width cabshield 10-gauge stainless steel with punched window in bulkhead
Boxed top rail
Square rear corner posts with integral tarp hooks, banjo chain slots & single 6" oval cut-out for STT lights
Include 3-holes in rear sill for clearance lighting

Install Crysteel Lo-Boy full-subframe scissor Hoist with body prop including the following:

Model LBS-516 with double-acting hydraulics, 50-degree dump angle
Capacity: 9.8 tons
Handheld 12-volt power pack with push-button control in cab

Install Manual Tarp System including the following:

Hand-crank style, mounted at the cabshield with mesh tarp material and rear tarp hooks

Install Custom stainless steel toolbox built inside dump front bed with hinged, slanted top including:

Toolbox to extend across full-width of dump interior
Top of toolbox at dump bulkhead to be at board pocket height, 22"
Depth of toolbox to be at least 12"
Front lid to be easily accessible over dump side, at side height, 14"

Install Custom Lighting & Electrical including the following:

Chassis upfitter switches for warning lights
One (1) SoundOff Pinnacle (mo. EPL7PDPC) amber/green mini lightbar centered on cabshield bracket
Twelve (12) SoundOff mPower (mo. EMPS20V38-P) amber/green flashers flush-mounted:
Two (2) on chassis grille (separate switch)
Two (2) side-facing on front fenders
Four (4) on cabshield, two front-facing & two side-facing
Two (2) rear-facing outside of front pillar on bracket, one each side
Two (2) rear-facing at top of rear pillar, one each side
Two (2) SoundOff 6" oval LED S/T/T in bottom cut-out of rear pillar, one each side

TRUCK & TRAILER *Specialties, Inc.*

900 Grand Oaks Drive | Howell, MI 48843 | www.ttspec.com | ph: (517) 552-3855 | fx: (517) 552-3666

LED body clearance lights and reflectors

Betts junction box at rear of dump

Backup alarm

Install Factory camera at rear

Install Rear Hitch Assembly including the following:

¾" steel mounting plate with multi-drill holes

Heavy-duty "D" rings for safety chains

OEM STT lights mounted alongside of hitch plate

Bolt-on 2-5/16" pintle/ball hitch

7-way flat-pin RV plug

Electric Brake Controller (to come with chassis/confirmed at chassis order)

Install Underbed Toolbox frame-mounted on driverside including the following:

Bawer (mo. TU822008) 24" wide x 18" deep x 18" high

Polished stainless construction toolbox, frame-mounted on curbside

Patented lockable T-handle, gas-shock door openers & rubber gasket seal

Install Western 8'6" Pro Plus Straight Plow including the following:

Snow deflector, cast-iron shoes, blade guides, loose hand-held controller, mounting & wiring

Receiver kit

UltraMount2 system

Install Mudflaps after drive tires

Paint Dump underbody, hoist and rear hitch painted Black

Above installed equipment pricing: \$36,098.00 ea.

Payment Terms: Net 30. Pricing effective for 30 days.

Pricing does not include any of the Rochester Hills RFQ discounts that may be applicable.

2% discount off total taken at invoice if payment received within 30 days.

FOB: City of Warren

Delivery: 5-6 months ARO, depending on chassis arrival

Thank you for the opportunity to quote.

Respectfully submitted by,

Jon Luea/Brian Bouwman

DATE: May 20, 2024
TO: Craig Treppa, Purchasing Agent, Controller's Office
FROM: Scott Raedel, Superintendent, Division of Public Works
RE: Purchase of two (2) new 2024 Chevrolet Silverado 3500 Zone Trucks

Craig,

The Division of Public Works (DPW) is requesting to purchase two (2) new 2024 Chevrolet 3500HD CC 4WD regular cab, 146" WB, 60" CA Work Truck, at a cost of \$50,628.00 each, for a total of \$101,256.00. Pricing for this is available to the City of Warren through the MiDeal contract, reference #071B7700178. DPW is also requesting the purchase of two (2) dump bodies from Truck & Trailer Specialties, at a cost of \$36,098.00 each, (for a total of \$72,196.00 for both dump bodies). Pricing for this is available to the City of Warren through the City of Rochester Hills, bid #RHP-RH-20-023. The total cost for these truck builds is \$173,452.00.

Funds are available in DPW Vehicle & Equipment account 101-1442-98103.

These new zone trucks will be replacing two of the older trucks in our fleet.

Zone trucks are DPW's most used vehicles. They are used in a variety of tasks including: towing trailers, hauling cold patch, hauling topsoil and other aggregates, carrying tools and equipment, as well as a variety of other tasks.

I will be available for any questions you or City Council may have in regards to this purchase or any future purchases by the Division of Public Works. I can be reached at (586) 759-9292.

Sincerely,



Scott Raedel
Superintendent
Division of Public Works

Attachments

SR/pkr

RESOLUTION

Product or Service: Two (2) 2024 Work Trucks

Document No: STA-W-1224

Requesting Department: Department of Public Works (DPW)

At a Regular Meeting of the City Council of the City of Warren, County of Macomb, Michigan, held on _____ at 7 p.m. Local Time, in the Council Chamber at the Warren Community Center Auditorium, 5460 Arden, Warren, Michigan.

PRESENT: Councilmembers: _____

ABSENT: Councilmembers: _____

The following preamble and resolution were offered by Councilmember _____ and supported by Councilmember _____.

Pursuant to Section 2-344 of the Code of Ordinances, the City may either participate in, sponsor, conduct, or administer a cooperative purchasing agreement for the procurement of any supplies, equipment, goods or services with one (1) or more public procurements units.

Upon performing a diligent inquiry, the DPW Superintendent has determined that is it necessary in the interest of the City, to acquire two (2) 2024 Work Trucks consisting of the cab/chassis from Todd Wenzel Buick-GMC, utilizing the State of Michigan Cooperative Contract # 071B7700178 and the dump bodies from Truck & Trailer Specialties, utilizing the Rochester Hills Cooperative Contract #RFP-20-023 at the prices indicated in the table below.

Funds are available in account number: 101-1422-98103.

PRICING SUMMARY			
VENDOR	DESCRIPTION	UNIT PRICE	EXTENDED PRICE (Quantity of 2)
Todd Wenzel Buick-GMC 35100 Ford Road Westland, MI 48185	Two (2) 2024 Chevrolet Silverado 3500HD 4x4 Reg Cab/Chassis	\$50,628.00	\$101,256.00
Truck and Trailer Specialties 6726 Hanna Lake Dutton, MI 49316	Two (2) Crysteel 9' S-Tipper Dump Bodies	\$ 36,098.00	\$ 72,196.00
GRAND TOTAL:			\$173,452.00

IT IS RESOLVED, that the cooperative purchase through Todd Wenzel Chevrolet and Truck & Trailer Specialties is hereby accepted by City Council in a total amount of \$173,452.00 (\$101,256.00 for Todd Wenzel and \$72,196.00 for Truck & Trailer Specialties) and payment is authorized by City Council to be paid to the vendors immediately upon successful completion and delivery from the vendors shown in the table.

IT IS FURTHER RESOLVED, that the Purchasing Agent and/or Mayor and City Clerk are authorized to execute any such documents that are necessary for this approval consistent with the terms of the:

- Cooperative Bid document
- Contract
- Resolution

and in such form that meets with the satisfaction of the City Attorney if review is required.

AYES: Councilmembers: _____

NAYS: Councilmembers: _____

DATE: MAY 15, 2024
 TO: MINDY MOORE, SECRETARY, WARREN CITY COUNCIL
 SUBJECT: FILE STA-W-1241; PURCHASE OF EIGHT (8) MOTOROLA HANDHELD PORTABLE APX RADIOS UTILIZING THE STATE OF MICHIGAN CONTRACT #190000001544

The Purchasing Division concurs with the Fire Department and recommends that City Council authorize the purchase of eight (8) Motorola Handheld Portable APX Radios, accessories, activation fees and the first year's annual maintenance fees from the vendors listed below, in the total amount of \$62,544.54.

VENDOR	DESCRIPTION	TOTAL COST
Motorola Solutions, Inc. 1301 E. Algonquin Road Schaumburg, IL 60196	2 - APX-8000 Radios (\$11,713.75 ea) 6 - APX-6000 Radios (\$ 6,076.17 ea)	\$ 59,884.54
Macomb County Emergency Management & Communications 117 S. Groesbeck Mt. Clemens, MI 48043	Annual Macomb County Fee (\$82.50 per device) for the maintenance of the "800" system.	\$ 660.00
State of Michigan Department of Management and Budget P.O. Box 30681 Lansing, MI 48909	Activation of radios to the State-wide system (\$250.00 per device)	\$ 2,000.00
GRAND TOTAL:		\$ 62,544.54

The Fire Department is requesting approval to purchase:

- Two (2) APX-8000 Mobile Radios
- Six (6) APX-6000 Mobile Radios
- Related supporting equipment and accessories
- "800 System" Maintenance
- Activation of the eight (8) radios

If approved by your honorable body, the Fire Department will be issuing these radios to its 40-hour/week personnel and the current radios being replaced will become part of the department's inventory for the operations division.

These new radios will be Phase II Compliant, which means that they will be able to be used when the department transitions to the new upgraded system (anticipated to occur in the 2025 fiscal year).

This purchase will be made utilizing the State of Michigan MiDeal Contract #190000001544.

Each radio will have a 5-year warranty on parts and labor.

Funds are available in the following Account: 101-1336-98401.

Respectfully Submitted,



Craig Treppa
Purchasing Agent

Approved By:	Signature	Date
Budget Director:		5/20/2024
Controller:		5/20/2024
MAYOR:		5/21/2024

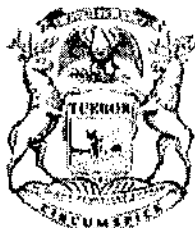

STATE OF MICHIGAN
CENTRAL PROCUREMENT SERVICES
 Department of Technology, Management, and Budget
 525 W. ALLEGAN ST., LANSING, MICHIGAN 48913
 P.O. BOX 30026 LANSING, MICHIGAN 48909

CONTRACT CHANGE NOTICE

Change Notice Number **2**
 to
 Contract Number **190000001544**

CONTRACTOR	MOTOROLA SOLUTIONS INC
	500 W. Monroe St.
	Chicago, IL 60661
	Melanie Leenhouts
	616-706-1723
	melanie.leenhouts@motorolasolutions.com
CV0016903	

STATE	Program Manager	Kate Jannereth	DTMB
		517-881-1031	
		jannerethk@Michigan.gov	
	Contract Administrator	Valerie Hiltz	DTMB
		(517) 249-0459	
		hiltzv@michigan.gov	

CONTRACT SUMMARY

MPPSCS CONTINUED SYSTEM UPDATES, EQUIPMENT, MAINTENANCE AND UPGRADES, AND ANCILLARY SYSTEMS PRODUCTS

INITIAL EFFECTIVE DATE	INITIAL EXPIRATION DATE	INITIAL AVAILABLE OPTIONS	EXPIRATION DATE BEFORE
October 1, 2019	December 31, 2029	0 - 0 Year	December 31, 2029
PAYMENT TERMS		DELIVERY TIMEFRAME	
NET 45		As per Delivery Order	
ALTERNATE PAYMENT OPTIONS			EXTENDED PURCHASING
<input type="checkbox"/> P-Card <input type="checkbox"/> PRC <input type="checkbox"/> Other			<input checked="" type="checkbox"/> Yes <input type="checkbox"/> No

MINIMUM DELIVERY REQUIREMENTS

N/A

DESCRIPTION OF CHANGE NOTICE

OPTION	LENGTH OF OPTION	EXTENSION	LENGTH OF EXTENSION	REVISED EXP. DATE
<input type="checkbox"/>		<input type="checkbox"/>		December 31, 2029
CURRENT VALUE	VALUE OF CHANGE NOTICE	ESTIMATED AGGREGATE CONTRACT VALUE		
\$99,900,000.00	\$0.00	\$99,900,000.00		

DESCRIPTION

Effective July 1, 2021 this contract is adding scope to Schedule A via Attachment 10- Critical Connect Subscription Service, adding Schedule H- Subscription Services Schedule, and updating Schedule B, all as attached.

All other terms, conditions, specifications and pricing remain the same. Per Contractor and Agency agreement and DTMB Central Procurement Services approval.

Purchase Order Checklist	
Marked as PO/ Contract/ Notice to Proceed on Company Letterhead (PO will not be processed without this)	
PO Number/ Contract Number	
PO Date	
Vendor = Motorola Solutions, Inc.	
Payment (Billing) Terms/ State Contract Number	
Bill-To Name on PO must be equal to the <i>Legal</i> Bill-To Name	
Bill-To Address	
Ship-To Address (If we are shipping to a MR location, it must be documented on PO)	
Ultimate Address (If the Ship-To address is the MR location then the Ultimate Destination address must be documented on PO)	
PO Amount must be equal to or greater than Order Total	
Non-Editable Format (Word/ Excel templates cannot be accepted)	
Bill To Contact Name & Phone # and EMAIL for customer accounts payable dept	
Ship To Contact Name & Phone #	
Tax Exemption Status	
Signatures (As required)	



WARREN POLICE DEPT, CITY OF
APX8000 AND APX6000 PORTABLE RADIO KITS

04/25/2024

The design, technical, pricing, and other information ("Information") furnished with this submission is confidential proprietary information of Motorola Solutions, Inc. or the Motorola Solutions entity providing this quote ("Motorola") and is submitted with the restriction that it is to be used for evaluation purposes only. To the fullest extent allowed by applicable law, the information is not to be disclosed publicly or in any manner to anyone other than those required to evaluate the Information without the express written permission of Motorola. MOTOROLA, MOTO, MOTOROLA SOLUTIONS, and the Stylized M Logo are trademarks or registered trademarks of Motorola Trademark Holdings, LLC and are used under license. All other trademarks are the property of their respective owners. © 2020 Motorola Solutions, Inc. All rights reserved.



QUOTE-2601801

04/25/2024

WARREN POLICE DEPT, CITY OF
Warren Fire Deptment
23295 SCHOENHERR
Warren, MI 48093

RE: Motorola Quote for APX8000 AND APX6000 PORTABLE RADIO KITS
Dear Bill Alter,

Motorola Solutions is pleased to present WARREN POLICE DEPT, CITY OF with this quote for quality communications equipment and services. The development of this quote provided us the opportunity to evaluate your requirements and propose a solution to best fulfill your communications needs.

This information is provided to assist you in your evaluation process. Our goal is to provide WARREN POLICE DEPT, CITY OF with the best products and services available in the communications industry. Please direct any questions to EDWARD HORVATH at EDHORVATH@CALLMC.COM.

We thank you for the opportunity to provide you with premier communications and look forward to your review and feedback regarding this quote.

Sincerely,

EDWARD HORVATH
Sr. Account Executive

Motorola Solutions Manufacturer's Representative



QUOTE-2601801
 APX8000 AND APX6000 PORTABLE
 RADIO KITS

Billing Address:
 WARREN POLICE DEPT, CITY OF
 Warren Fire Deptment
 23295 SCHOENHERR
 Warren, MI 48093
 US

Shipping Address:
 Warren Fire Deptment
 23295 SCHOENHERR
 Warren, MI 48093
 US

Quote Date:04/25/2024
 Expiration Date:06/24/2024
 Quote Created By:
 EDWARD HORVATH
 Sr. Account Executive
 EDHORVATH@CALLMC.COM
 3132183450

End Customer:
 WARREN POLICE DEPT, CITY OF
 Bill Alter
 fireadmin@warrenfiredept.org
 586-756-2800 x 3910

Contract: 35115 - STATE OF MICHIGAN,
 MA# 190000001544
 Payment Terms:30 NET

Line #	Item Number	Description	Qty	List Price	Sale Price	Ext. Sale Price
	APX™ 8000 Series	APX8000				
1	H91TGD9PW7AN	APX 8000 ALL BAND PORTABLE MODEL 3.5	2	\$7,774.00	\$5,830.50	\$11,661.00
1a	H869BW	ENH: MULTIKEY	2	\$363.00	\$272.25	\$544.50
1b	Q806CB	ADD: ASTRO DIGITAL CAL OPERATION	2	\$567.00	\$425.25	\$850.50
1c	Q361AN	ADD: P25 9600 BAUD TRUNKING	2	\$330.00	\$247.50	\$495.00
1d	QA00580AA	ADD: TDMA OPERATION	2	\$495.00	\$371.25	\$742.50
1e	Q15AJ	ADD: AES/DES-XL/DES-OFB ENCRYPTION AND ADP	2	\$879.00	\$659.25	\$1,318.50
1f	Q887AU	ADD: 5Y ESSENTIAL SERVICE	2	\$306.00	\$306.00	\$612.00
1g	QA09007AA	ADD: OUT OF THE BOX WIFI PROVISIONING	2	\$0.00	\$0.00	\$0.00
1h	QA09001AB	ADD: WIFI CAPABILITY	2	\$330.00	\$247.50	\$495.00
1i	H38BS	ADD: SMARTZONE OPERATION	2	\$1,650.00	\$1,237.50	\$2,475.00



Any sales transaction following Motorola's quote is based on and subject to the terms and conditions of the valid and executed written contract between Customer and Motorola (the "Underlying Agreement") that authorizes Customer to purchase equipment and/or services or license software (collectively "Products"). If no Underlying Agreement exists between Motorola and Customer, then Motorola's Standard Terms of Use and Motorola's Standard Terms and Conditions of Sales and Supply shall govern the purchase of the Products.
 Motorola Solutions, Inc.: 500 West Monroe, United States - 60661 - #: 36-115800



QUOTE-2601801
APX8000 AND APX6000 PORTABLE
RADIO KITS

Line #	Item Number	Description	Qty	List Price	Sale Price	Ext. Sale Price
1j	QA09113AB	ADD: BASELINE RELEASE SW	2	\$0.00	\$0.00	\$0.00
2	PMNN4486A	BATT IMPRES 2 LIION R IP67 3400T	2	\$188.27	\$99.00	\$198.00
3	NNTN8860B	CHARGER, SINGLE-UNIT, IMPRES 2, 3A, 115VAC, US/NA	8	\$186.50	\$139.88	\$1,119.04
4	PMMN4136B	XVP830 REMOTE SPEAKER MICROPHONE NO CHANNEL KNOB	8	\$486.00	\$364.50	\$2,916.00
	APX™ 6000 Series	APX6000				
5	H98UCF9PW6BN	APX6000 700/800 MODEL 2.5 PORTABLE	6	\$3,595.00	\$2,696.25	\$16,177.50
5a	H869BZ	ENH; MULTIKEY	6	\$363.00	\$272.25	\$1,633.50
5b	Q361AR	ADD: P25 9600 BAUD TRUNKING	6	\$330.00	\$247.50	\$1,485.00
5c	QA00580AC	ADD: TDMA OPERATION	6	\$495.00	\$371.25	\$2,227.50
5d	Q15AK	ADD: AES/DES-XL/DES-OFB ENCRYPTION AND ADP	6	\$879.00	\$659.25	\$3,955.50
5e	Q887AU	ADD: 5Y ESSENTIAL SERVICE	6	\$306.00	\$306.00	\$1,836.00
5f	H122BR	ALT: 1/4 WAVE 7/8 STUBBY (NAR6595)	6	\$26.00	\$19.50	\$117.00
5g	H38BT	ADD: SMARTZONE OPERATION	6	\$1,320.00	\$990.00	\$5,940.00
5h	QA09113AB	ADD: BASELINE RELEASE SW	6	\$0.00	\$0.00	\$0.00
5i	Q806BM	ADD: ASTRO DIGITAL CAI OPERATION	6	\$567.00	\$425.25	\$2,551.50
6	PMNN4485A	BATT IMPRES 2 LIION R IP68 2550T	6	\$168.63	\$89.00	\$534.00

Subtotal \$79,442.32
 Total Discount Amount \$19,557.78
Grand Total \$59,884.54(USD)

Notes:



Any sales transaction following Motorola's quote is based on and subject to the terms and conditions of the valid and executed written contract between Customer and Motorola (the "Underlying Agreement") that authorizes Customer to purchase equipment and/or services or license software (collectively "Products"). If no Underlying Agreement exists between Motorola and Customer, then Motorola's Standard Terms of Use and Motorola's Standard Terms and Conditions of Sales and Supply shall govern the purchase of the Products.
 Motorola Solutions, Inc.: 500 West Monroe, United States - 60661 - #: 36-1115809



QUOTE-2601801
APX8000 AND APX6000 PORTABLE
RADIO KITS

- Pricing contained herein does not include the one-time MPSCS activation fee of \$250.00 per radio. Total for this quote would be \$2,000.00 invoiced by MPSCS directly to your department. Programming to be performed by Macomb County Radio Department.
- Unless otherwise noted, this quote excludes sales tax or other applicable taxes (such as Goods and Services Tax, sales tax, Value Added Tax and other taxes of a similar nature). Any tax the customer is subject to will be added to invoices.



Any sales transaction following Motorola's quote is based on and subject to the terms and conditions of the valid and executed written contract between Customer and Motorola (the "Underlying Agreement") that authorizes Customer to purchase equipment and/or services or license software (collectively "Products"). If no Underlying Agreement exists between Motorola and Customer, then Motorola's Standard Terms of Use and Motorola's Standard Terms and Conditions of Sales and Supply shall govern the purchase of the Products.
Motorola Solutions, Inc. 500 West Monroe, United States - 60661 ~ #: 36-1115800

Purchase Order Checklist	
Marked as PO/ Contract/ Notice to Proceed on Company Letterhead (PO will not be processed without this)	
PO Number/ Contract Number	
PO Date	
Vendor = Motorola Solutions, Inc.	
Payment (Billing) Terms/ State Contract Number	
Bill-To Name on PO must be equal to the <i>Legal</i> Bill-To Name	
Bill-To Address	
Ship-To Address (If we are shipping to a MR location, it must be documented on PO)	
Ultimate Address (If the Ship-To address is the MR location then the Ultimate Destination address must be documented on PO)	
PO Amount must be equal to or greater than Order Total	
Non-Editable Format (Word/ Excel templates cannot be accepted)	
Bill To Contact Name & Phone # and EMAIL for customer accounts payable dept	
Ship To Contact Name & Phone #	
Tax Exemption Status	
Signatures (As required)	

May 9, 2024

Craig Treppa
Purchasing Agent

Subject: Handheld portable radios (APX – 6000 & APX – 8000)

Craig



WARREN FIRE DEPARTMENT

23295 Schoenherr
Warren, MI 48089
(586) 756-2800
www.cityofwarren.org

The fire department desires to purchase eight (8) handheld portable radios from Motorola Solutions in the total amount of \$59,884.54. The purchase will include two (2) APX – 8000 radios in the \$11,713.75 per radio inclusive of accessories along with six (6) APX – 6000 radios in the total amount of \$36,457.04 and unit cost of \$6,076.17 inclusive of all accessories. Additionally, the project will require the department to pay a templating fee of \$250.00 per radio and total cost of \$2,000.00 as well as the Macomb County Radio programming fee in the amount of \$82.50 per radio and total cost of \$660.00. The total project cost equals **\$62,544.54**. The eight (8) handheld portable radios will be used by 40-hour personnel and their old radios will become part of our inventory for the operations division of the department. The new radios are phase II compliant and therefore when we purchase the next generation of radios these radios will be compatible with the new radios ensuring that we are not wasting taxpayer money or radios that cannot be used when we transition to the upgraded system.

The radios that are being purchased are not the ruggedized versions of the radios that we have purchased in the past and therefore they cost less than the ruggedized versions of the same radio. Additionally, the two (2) APX – 8000 radios also have additional channel and feature capabilities that are not needed for everyday operations. With the purchase of these additional eight (8) radios it is anticipated that the department will have a sufficient quantity of portable radios to ensure that we have enough radios until we take delivery of the new phase II compliant radios that we are anticipating ordering sometime in the upcoming fiscal year. Assuming that we do move forward with the current plan to purchase the phase II compliant radios the department does not expect that Motorola will be able to deliver the new radios to the department for approximately 12-18 months after the contract is approved by council and ordered by the city.

Funds are available in Account # 101-1336-98401.

Please direct questions to my attention at Ext. 3100.

Wilburt McAdams
Fire Commissioner

Sole Procurement

Document No: STA-W-1241

Product or Service: Motorola Handheld Portable Radios (APX – 6000 & APX – 8000)

Requesting Department: Fire Department

At a Regular Meeting of the City Council of the City of Warren, County of Macomb, Michigan, held on _____, 2024, at 7 p.m. Eastern Daylight-Saving Time, in the Council Chamber at the Warren Community Center Auditorium, 5460 Arden, Warren, Michigan.

PRESENT: Councilmembers: _____

ABSENT: Councilmembers: _____

The following preamble and resolution were offered by Councilmember _____ and supported by Councilmember _____.

Upon performing a diligent inquiry, the Fire Commissioner has determined that it is necessary in the interests of the Fire Department and the City, to acquire supplies, materials, equipment and/or goods from a sole source. Justification for a sole source purchase includes that the City selected Motorola Solutions Inc., as the sole source manufacturer (State of Michigan Contract # MA190000001544) of portable and base radios and related accessories that are used by the fire, police, and public services departments. Additionally, the fire department desires to maintain standardization of equipment used by our department and other city departments. The eight (8) new handheld portable radios will be issued to fire administration personnel and their current ruggedized radios will be added to our inventory of existing portable radios used by the operations division to ensure that we have enough radios until the new radios are purchased and delivered to the department as early as 2025.

The Purchasing Agent has conducted a review and concurs with the sole procurement.



CITY CONTROLLER'S OFFICE

ONE CITY SQUARE, SUITE 425

WARREN, MI 48093-5289

(586) 574-4600

FAX (586) 574-4614

www.cityofwarren.org

DATE: MAY 15, 2024

TO: MINDY MOORE, SECRETARY, WARREN CITY COUNCIL

SUBJECT: TRI-W-0664; RECOMMENDATION TO EXTEND THE AWARD FOR APPLE COMPUTER EQUIPMENT AND SUPPLIES FOR THE FIRE DEPARTMENT

The Purchasing Division concurs with the Fire Department and recommends that City Council authorize the participation of the Fire Department in the extension of the REMC Contract #6640182 (see the attached amendment), for the purchase of Apple Computer Equipment and Supplies through Apple Inc., One Apple Park Way, Cupertino, CA 95014, for the period of July 1, 2024 through June 30, 2029, in an annual amount not to exceed \$35,000.00.

On April 12, 2022 Warren City Council approved an award to Apple, Inc., for Apple computer equipment and supplies for a two-year period, in an annual amount not to exceed \$35,000.00.

The Fire Department utilizes Apple Inc. to purchase its Apple Computer supplies, including monitors, printers, etc. They have utilized Apple Inc. for many years and have been satisfied with their product, service, and pricing.

If approved by your honorable body, this agreement will commence on July 1, 2024 or official date of City Council approval, whichever occurs later, and run through June 30, 2029.

Funds are available in the Fire Department Account: 101-1336-74000.

Respectfully submitted,

Craig Treppa
Purchasing Agent

Approved By:	Signature	Date
Budget Director:		5/20/2024
Controller:		5/20/2024
MAYOR:		5/21/2024



Apple

Confidential Information





Amendment to the Contract

This amendment ("**Amendment**") amends the 2019-2024 COMPUTERS AND NETWORKING CONTRACT ("**Contract**") entered into on February 12, 2019 by and between Apple Inc., located at One Apple Park Way, Cupertino, California 95014 ("**Apple**") and:

Company Legal Name ("**Department**"): REMC ASSOCIATION OF MICHIGAN

DBA Name: REMC ASSOCIATION

Address: P.O. BOX 607, MARQUETTE, MI 49855

Capitalized terms used but not defined in this Amendment have the meanings set forth in the Contract.

In the event of any conflict between the terms of this Amendment and the Contract, the terms of this Amendment will prevail.

The Parties hereby agree to amend the Contract as follows:

1. **Section III.A. Term.** This section is stricken in its entirety and replaced with the following:

A. Term. The term of this Contract shall begin on the Effective Date and end on June 30, 2029.

2. **Section IV.A. Pricing.** The following is added as a second paragraph to this section:

At the beginning of February of each year of the Contract, the Parties agree to work together on a new Award Letter which sets forth the agreed upon device pricing, model, specifications, and value adds (if applicable) for that year in lieu of any REMC SAVE bid response by Apple. Price proposals set forth in the Award Letter are based on the current device specified per product description and are subject to change by Apple without notice to REMC.

3. **Effect of Amendment to Agreement**

Except as set forth in this Amendment, the Agreement shall continue in full force and effect in accordance with its terms.

The duly authorized representatives of the Parties execute this Amendment as of the Effective Date stated below.





REMC Association

SIGNATURE: Heather J. Kowalski

PRINT NAME: Heather J. Kowalski

PRINT TITLE: President

DATE: 2/7/24

Apple Inc.

SIGNATURE: Johnny Mendoza

PRINT NAME: Johnny Mendoza

PRINT TITLE: Project Coordinator

EFFECTIVE DATE: 2/8/2024





May 14, 2024

Craig Treppa
Purchasing Agent

WARREN FIRE DEPARTMENT

23295 Schoenherr
Warren, MI 48089
(586) 756-2800
www.cityofwarren.org

Subject: REMC Save Apple Purchasing Agreement

Craig

The fire department desires to extend the purchasing agreement with Apple Government Purchasing for an additional five (5) years through June 30, 2029, in the amount of up to \$35,000.00 per fiscal year. The fire department using Apple computers as well as apple-based hardware and software applications. Over the last several years the department has been able to replace outdated computers, hardware, and software as needed to maintain our network at the fire administration building, fire stations and the laptops and tablets used in fire apparatus and squads.

The department expects to continue using apple products for the foreseeable future and therefore, having a blanket purchase order with Apple and REMC will save the city money as well as allow the department to efficiently make needed purchases to maintain our network of computers, purchases licenses for the software installed on computer and purchase all other ancillary tools, parts, and supplies.

Funds are available in Account # 101-1336-74000.

Please contact me with questions at Ext. 3100.

Professionally,

A handwritten signature in black ink that reads "W. McAdams".

Wilburt McAdams
Fire Commissioner



WARREN FIRE DEPARTMENT
INTER-DEPARTMENT COMMUNICATION
OFFICE OF THE MIS DIVISION

MEMO TO: Commissioner McAdams *WMA*
FROM: MIS Specialist Bill Alter
DATE: May 3, 2024
SUBJECT: REMC Save Apple Purchasing Agreement

Commissioner:

As you know, we purchased Apple computers, devices, and accessories using Apple Government Purchasing with pricing based on the REMC Save pricing agreement. The current contract expires on June 30, 2024. Apple and REMC Save have agreed to renew the contract until June 30, 2029.

This purchasing agreement has been a huge asset to the Fire Department as we continue to update our technology infrastructure. Over the past three years the department has been able to replace computers and devices as old as 20 years. Using this agreement, we can continue to update and deploy the newest technology.

The MIS Division is requesting the approval of this purchasing agreement for the Fire Department to be able to purchase Apple computers, devices, and accessories at a cost of up to \$35,000 per fiscal year until the expiration of the contract on June 30, 2029.

Please see the attached purchasing contract from Apple.

Please let me know if you have any questions.

Bill Alter
MIS Specialist

RESOLUTION

Document No: TRI-W-0664 Extension

Product or Service: Apple computer equipment, devices, and supplies

Requesting Department: Fire

At a Regular Meeting of the City Council of the City of Warren, County of Macomb, Michigan, held on _____, 2024 at 7 p.m. Local Time, in the Council Chamber at the Warren Community Center Auditorium, 5460 Arden, Warren, Michigan.

PRESENT: Councilmembers: _____

ABSENT: Councilmembers: _____

The following preamble and resolution were offered by Councilmember _____ and supported by Councilmember _____.

On April 12, 2022 this Council adopted a resolution to award the purchase of Apple computer equipment and supplies to Apple Inc., for a two-year period, in an annual amount not to exceed \$35,000.00.

Pursuant to Section 2-344 of the Code of Ordinances, the City may either participate in, sponsor, conduct, or administer a cooperative purchasing agreement for the procurement of any supplies, equipment, goods or services with one (1) or more public procurement units.

Upon performing a diligent inquiry, the Fire Commissioner has determined that it is necessary in the interests of the Fire Department and the City, to extend the award for purchasing Apple computer equipment, devices, and supplies through the REMC Association of Michigan (REMC SAVE) contract #640182 (see attached contract and amendment), from Apple Inc., One Apple Park Way, Cupertino, CA 95014, commencing

on July 1, 2024 or the official date of City Council approval, whichever occurs later, and run through June 30, 2029, at an annual amount not to exceed \$35,000.00.

Apple Inc. has been selected for the cooperative purchase. The purchasing agent has conducted a review and concurs with the cooperative purchasing.

Funds are available in account number: 101-1336-74000

IT IS RESOLVED, that the cooperative purchase though Apple Inc. is hereby accepted by City Council commencing July 1, 2024 or on the official date of City Council approval, whichever occurs later, and runs through June 30, 2029, at an annual amount not to exceed \$35,000.00.

IT IS FURTHER RESOLVED, that the remit to address for Apple Inc., is PO Box 281877, Atlanta, GA 30384-1877.

IT IS FURTHER RESOLVED, that the Purchasing Agent and/or Mayor and City Clerk are authorized to execute any such documents that are necessary for this approval consistent with the terms of the:

- Cooperative Bid Document
- Contract
- Resolution

and in such form that meets with the satisfaction of the City Attorney if review is required.

AYES: Councilmembers: _____

NAYS: Councilmembers: _____

RESOLUTION DECLARED ADOPTED this _____ day of _____, 2024.

Mindy Moore
Secretary of the Council



CITY CONTROLLER'S OFFICE

ONE CITY SQUARE, SUITE 425

WARREN, MI 48093-5289

(586) 574-4600

FAX (586) 574-4614

www.cityofwarren.org

DATE: MAY 7, 2024

TO: MINDY MOORE, SECRETARY, WARREN CITY COUNCIL

SUBJECT: FILE STA-W-1224 - PURCHASE OF ONE (1) POLICE VEHICLE THROUGH THE STATE OF MICHIGAN MIDEAL CONTRACT #071B7700177

The Purchasing Division concurs with the Police Department and recommends that City Council award the purchase of one (1) Police Vehicle utilizing the State of Michigan Cooperative Vehicle Contract #071B7700177 in the amount of \$51,522.00.

If the City Council approves this purchase, payment shall be authorized to be made immediately upon successful delivery from the recommended vendor.

This vehicle will be used by a Warren Police Officer assigned to the Home Security Branch of the Federal Government.

Due to the confidential nature of this purchase, the backup information (name of the vendor, make and model of the vehicle, etc.) is being kept confidential. Your honorable body can obtain this information by contacting Staff Sergeant Mark Ptaszek or the Purchasing Agent, Craig Treppa.

Funds are available in the amount of \$51,522.00 from the Drug Forfeiture Account: 261-9261-82214.

Respectfully Submitted,

Craig Treppa
Purchasing Agent

Approved By:	Signature	Date
Budget Director:		5/20/2024
Controller:		5/20/2024
MAYOR:		5/21/2024



WARREN POLICE DEPARTMENT
20000 CIVIC CENTER BLVD.
WARREN, MI 48093
(586) 574-4700
FAX (586) 574-4662
www.cityofwarren.org

May 6, 2024

Mr. Craig Treppa, Purchasing Agent, City of Warren

RE: VEHICLE PURCHASE FOR POLICE-UTILIZING MICHIGAN "MI-DEAL" CONTRACT #071B7700177

Dear Mr. Treppa:

Just recently, the City of Warren Police Department has committed members of the Warren Police Department to various entities like Homeland Security, C.H.I.E.F., and D.E.A./TFO positions. These moves were executed on behalf of Commissioner Rushton and Mayor Lori Stone to assist in combating narcotics and various criminal elements in and around our city.

A specific K-9 Officer was chosen as a representative of the Warren Police Department to be assigned to Homeland Security Branch of the Federal Government. The Officer is currently using a Black 2023 Chevrolet Tahoe that is up-fitted for Police Patrol. This vehicle is not suited to the needs as an Undercover Officer. It would be fiscally irresponsible to remove the "upfitting" to the vehicle when it can be used as a K-9 Patrol Unit for Warren Police for other K-9 Units.

The Police Department is requesting the purchase of the "**Vehicle A**" for the Plain-Clothes work that the Officer will be doing. This vehicle would be without a cage or police markings, and allows the Officer to effectively surveil targets of investigations without being recognized as an Officer, and effectively move around assigned areas without immediate detection. This vehicle would only be assigned to the Officer and K-9 for these purposes.

The quote from the Fleet Manager from the respective company indicates "**Vehicle A**" as described is available and would cost \$51,522.00. It is the recommendation/request of the Warren Police Department to purchase this vehicle. The account to purchase the vehicle would be under Forfeiture account #261-9261-82214 in cooperation with a Michigan Mi-Deal Contract #071B7700177.

<u>Quantity</u>	<u>Vehicle</u>		<u>Total Cost</u>
1	<u>VEHICLE "A"</u> Undercover Vehicle Homeland Security	\$51,522.00 Michigan State Contract #071B7700177	\$51,522.00

As you are aware, the seizures that narcotics officers make supply funds to the Forfeiture account upon disposition. It is the Warren Police Departments' belief that this vehicle will be more than paid for by the work of the Designated Homeland Security officer within a year. Thank you in advance for your assistance. If you have any questions, please contact me at 574-4768.

Respectfully,

Mark Plaszek Staff Sergeant
Administrative Services Bureau

Charles Rushton, Commissioner

RESOLUTION

Document No: STA-W-1224
Product or Service: Police Vehicle
Requesting Department: Police Department

At a Regular Meeting of the City Council of the City of Warren, County of Macomb, Michigan, held on _____ 2024 at 7 p.m. Local Time, in the Council Chamber at the Warren Community Center Auditorium, 5460 Arden, Warren, Michigan.

PRESENT: Councilmembers: _____

ABSENT: Councilmembers: _____

The following preamble and resolution were offered by Councilmember _____ and supported by Councilmember _____.

Pursuant to Section 2-344 of the Code of Ordinances, the City may either participate in, sponsor, conduct, or administer a cooperative purchasing agreement for the procurement of any supplies, equipment, goods or services with one (1) or more public procurement units.

Upon performing a diligent inquiry, the Commissioner of the Police Department has determined that it is necessary in the interest of the Police Department and the City, to acquire supplies, equipment, or goods pursuant to cooperative purchasing.

The Police Department recommends awarding the purchase of one (1) Police Vehicle utilizing the State of Michigan Cooperative Vehicle Contract #071B7700177 in the amount of \$51,522.00.

The vehicle will be used by a Warren Police Officer assigned to the Home Security Branch of the Federal Government.

Due to the confidential nature of this purchase, the backup information (name of the vendor, make and model of the vehicle, etc.) is being kept confidential. Your honorable body can obtain this information by contacting the Police Department or the Purchasing Agent.

The purchasing agent has conducted a review and concurs with the cooperative purchasing.

Funds in the amount of \$51,522.00 are available in the following Account: 261-9261-82214.

IT IS RESOLVED, that the cooperative purchase is hereby accepted by City Council.

IT IS FURTHER RESOLVED, that City Council authorizes payment to be made to the awarded vendor immediately upon City acceptance of the vehicle.

IT IS FURTHER RESOLVED, that the Purchasing Agent and/or Mayor and City Clerk are authorized to execute any such documents that are necessary for this approval consistent with the terms of the:

- X Cooperative Bid Documents
- Contract
- X Resolution

and in such form that meets with the satisfaction of the City Attorney if review is required.

AYES: Councilmembers: _____

NAYS: Councilmembers: _____

RESOLUTION DECLARED ADOPTED this _____ day of _____, 2024.

Mindy Moore
Secretary of the Council

CERTIFICATION

STATE OF MICHIGAN)
) SS.
COUNTY OF MACOMB)

I, Sonja Buffa, duly elected City Clerk for the City of Warren, Macomb County, Michigan, hereby certifies that the foregoing is a true and correct copy of the resolution adopted by the Council of the City of Warren at its meeting held on _____, 2024.

Sonja Buffa
City Clerk



CITY CONTROLLER'S OFFICE

ONE CITY SQUARE, SUITE 425
WARREN, MI 48093-5289
(586) 574-4600
FAX (586) 574-4614
www.cityofwarren.org

DATE: MAY 6, 2024
TO: MINDY MOORE, SECRETARY, WARREN CITY COUNCIL
SUBJECT: TRI-W-1215; AWARD RECOMMENDATION FOR THE PURCHASE OF PROOFPOINT EMAIL SECURITY SUITE AND SUPPORT SERVICES UTILIZING THE SOURCEWELL COOPERATIVE CONTRACT #121923

The Purchasing Division concurs with the I.S.Department and recommends that City Council award the purchase of Proofpoint Email Security Suite and Support Services from GovConnction, Inc., 732 Milford Road, Merrimack, NH 03054, Sourcewell Cooperative Contract #121923, for a three year period in the total amount of \$109,038.93 (\$36,346.31 annually).

The City's email server has been hit extremely hard with phishing and spam attempts. Although Microsoft offers basic protections, it is not robust enough to provide the needed protections the City requires. Email security suites can help protect email accounts and communications from unauthorized access, compromise, or loss. They can also help to detect and resolve email threats, which would otherwise lead to breaches and the risk of harmful viruses, such as malware, and others.

The I.S. Manager is recommending the purchase of Proofpoint Email Security Suite and Support Services, as they are the recognized leader in enterprise level email security. In fact, they have been rated the top 3 on Gartner's magic quadrant over the last six years. Gartner's magic quadrant is the resource that the I.S. industry uses to measure performance and viability of a vendor.

Funds for these purchases are available in the following Account: 101-1258-98001.

Respectfully submitted,

Craig Treppa
Purchasing Agent

Approved By:	Signature	Date
Budget Director:		5/20/2024
Controller:		5/20/2024
MAYOR:		5/21/2024



Solicitation Number: RFP #121923

CONTRACT

This Contract is between Sourcewell, 202 12th Street Northeast, P.O. Box 219, Staples, MN 56479 (Sourcewell) and GovConnection, Inc. dba Connection – Public Sector Solutions, 732 Milford Road, Merrimack, NH 03054 (Supplier).

Sourcewell is a State of Minnesota local government unit and service cooperative created under the laws of the State of Minnesota (Minnesota Statutes Section 123A.21) that offers cooperative procurement solutions to government entities. Participation is open to eligible federal, state/province, and municipal governmental entities, higher education, K-12 education, nonprofit, tribal government, and other public entities located in the United States and Canada. Sourcewell issued a public solicitation for Technology Products and Services with Related Solutions from which Supplier was awarded a contract in Category 1.

Supplier desires to contract with Sourcewell to provide equipment, products, or services to Sourcewell and the entities that access Sourcewell's cooperative purchasing contracts (Participating Entities).

1. TERM OF CONTRACT

A. **EFFECTIVE DATE.** This Contract is effective upon the date of the final signature below.

EXPIRATION DATE AND EXTENSION. This Contract expires February 27, 2028, unless it is cancelled sooner pursuant to Article 22. This Contract allows up to three additional one-year extensions upon the request of Sourcewell and written agreement by Supplier. Sourcewell retains the right to consider additional extensions beyond seven years as required under exceptional circumstances.

B. **SURVIVAL OF TERMS.** Notwithstanding any expiration or termination of this Contract, all payment obligations incurred prior to expiration or termination will survive, as will the following: Articles 11 through 14 survive the expiration or cancellation of this Contract. All other rights will cease upon expiration or termination of this Contract.

**Proposal Evaluation
Technology Products and Services with Related Solutions RFP #121923
Category 1**



Requirement	Appix, Inc.	Autilive, LLC	ByteStream, LLC	CDN Services, LLC	Comerge Technology Solutions USA, LLC	Clare Tech Services, Inc.	GoCommastika, Inc.	HP Inc.	Reaser, Inc.	Real System Solutions, Inc.	Mareo Technologies, LLC
Compliance to RFP	14	33	46	46	41	42	43	44	44	45	46
Requirements	128	101	314	348	307	362	348	306	339	339	350
Ability to Sell RFP Product	27	47	53	64	67	65	65	65	62	62	67
Service	18	80	78	30	65	78	43	66	63	63	74
Ability to Sell RFP Product	11	43	37	44	43	41	43	47	43	43	54
Service	21	87	58	65	58	60	61	66	61	61	68
Ability to Sell RFP Product	23	33	42	42	42	41	41	41	41	41	50
Service	50	52	147	185	173	175	175	170	173	173	150
Ability to Sell RFP Product	11	18	33	33	18	18	18	18	18	18	17
Service	1600	1600	1600	1600	1600	1600	1600	1600	1600	1600	1600
Total Points	171	171	171	171	171	171	171	171	171	171	171
Total Order	171	171	171	171	171	171	171	171	171	171	171

Requirement	New Tech Solutions, Inc.	People Wireless Solutions Technology Solutions	Recruitment Learning, Inc.	SH International Corp	Sigma Creative Group, Inc.	Solstice Information Resource Corp	Stargate Communications	Waldman Technology	Zenics, LLC
Compliance to RFP	42	42	42	44	44	44	43	43	43
Requirements	320	320	320	321	321	321	321	321	320
Ability to Sell RFP Product	66	64	64	66	66	66	62	62	67
Service	81	83	83	85	85	85	73	73	84
Ability to Sell RFP Product	18	18	18	18	18	18	18	18	18
Service	51	51	51	50	50	50	50	50	41
Ability to Sell RFP Product	172	172	172	172	172	172	172	172	172
Service	172	172	172	172	172	172	172	172	172
Ability to Sell RFP Product	71	71	71	71	71	71	71	71	71
Service	171	171	171	171	171	171	171	171	171
Total Points	71	71	71	71	71	71	71	71	71
Total Order	71	71	71	71	71	71	71	71	71

Declassified by:
Ken Austin
48356185461840
Ken Austin, MBA, CPPM, MSP-CPP, Procurement Manager

Declassified by:
Michael Minoz
00024E0D3E45
Michael Minoz, CPPM, Senior Procurement Analyst

Declassified by:
Nicole Lueh
2878E30136A34E1
Nicole Lueh, Procurement Analyst



SALES QUOTE

GovConnection, Inc.
732 Milford Road
Merrimack, NH 03054

Account Executive: Daniel Loofe
Phone: (800) 800-0019 ext. 75530
Fax: 603-683-0834
Email: daniel.loofe@connection.com

25629707.02

PLEASE REFER TO THE ABOVE
QUOTE # WHEN ORDERING

Date: 5/9/2024
Valid Through: 6/8/2024
Account #: S02598

Customer Contact: Shumon Hakim
Email: shakim@cityofwarren.org

Phone: (586) 574-4612
Fax:

QUOTE PROVIDED TO: AB#: 19758 CITY OF WARREN PURCHASING DEPT SUITE 425 1 CITY SQUARE WARREN, MI 48093 US (586) 574-4600	SHIP TO: AB#: 15394253 CITY OF WARREN SHUMON HAKIM 1 CITY SQ STE 420 WARREN, MI 48093 US (586) 574-4612
---	---

DELIVERY	FOB	SHIP VIA	SHIP WEIGHT	TERMS	CONTRACT ID#
5-30 Days A/R/O	Destination	Small Pkg Ground Service Level	.00 lbs	Net 30	SOURCEWELL #121923

Important Notice: — THIS QUOTATION IS SUBJECT TO THE FOLLOWING Terms of Sale: All purchases from GovConnection, Inc. are subject to the Terms and Conditions of our Sourcewell Contract # 121923. Any Order accepted by GovConnection for the items included in this Quotation is expressly limited to those Terms and Conditions; any other terms and conditions referenced or appearing in your Purchase Order are considered null and void. No other terms and conditions shall apply without the written consent of GovConnection, Inc. Please refer to our Quote Number in your order.

* Line #	Qty	Item #	Mfg. Part #	Description	Mfg.	Price	Ext
1	1,001	41788236	PFPT-B-P0F-S-A	Corp. NPRE Email Protect TAP URL Attachment Def TAP URL Iso (VAP only) Thrt Resp AutoPull F-Sec SaaS Proofpoint	Proofpoint	\$ 36.31	\$ 36,346.31
2	1	41781518	PP-SUP-PS	Corp. Platinum Level Support Proofpoint	Proofpoint	\$ -	\$ -
3	1	41660886	PP-PST-IS-IMP	Corp. Infosec PS Implementation Services Proofpoint	Proofpoint	\$ -	\$ -
Subtotal						\$	36,346.31
Fee						\$	0.00
Shipping and Handling						\$	0.00
Tax							Exempt
Total						\$	36,346.31



ORDERING INFORMATION

GovConnection, Inc. DBA Connection
SOURCEWELL Contract # 121923
Contract Expiration: 27 February 2028

Please contact your account manager with questions.

Ordering Address
GovConnection, Inc.
732 Milford Road
Merrimack, NH 03054

Remittance Address
GovConnection, Inc.
PO Box 536477
Pittsburgh, PA 15253-5906

Please reference the Contract # on all purchase orders.

TERMS & CONDITIONS

Payment Terms:	NET 30 (subject to approved credit)
FOB Point:	DESTINATION (within Continental US)
Maximum Order Limitation:	NONE
Delivery Time:	1-30 DAYS ARO
FEIN:	52-1837891
DUNS Number:	80-967-8782
Cage Code:	OGTJ3
Business Size:	LARGE

WARRANTY: Manufacturer's Standard Commercial Warranty

NOTE: It is the end user's responsibility to review, understand and agree to the terms of any End User License Agreement (EULA).

Important Notice: --- THIS QUOTATION IS SUBJECT TO THE FOLLOWING Terms of Sale: All purchases from GovConnection, Inc. are subject to the Terms and Conditions of our Sourcewell Contract # 121923. Any Order accepted by GovConnection for the items included in this Quotation is expressly limited to those Terms and Conditions; any other terms and conditions referenced or appearing in your Purchase Order are considered null and void. No other terms and conditions shall apply without the written consent of GovConnection, Inc. Please refer to our Quote Number in your order.

If you require a hard copy invoice for your credit card order, please visit the link below and click on the Proof of Purchase/Invoice link on the left side of the page to print one: <https://www.govconnection.com/web/Shopping/ProofOfPurchase.htm>

Notice on Tariff Tax Impacts: Please be aware that the pricing shown in this quote is potentially subject to change at time of order placement due Federal Government tax law changes resulting in increases in Tariff's assessed on imports and exports, which are outside our control and the control of our suppliers. Please confirm pricing with your Account Manager prior to order placement. We apologize for this inconvenience.

Please forward your Contract or Purchase Order to:
SLEDOPS@connection.com
QUESTIONS: Call 800-800-0019
FAX: 603.683.0374



INFORMATION SYSTEMS
ONE CITY SQUARE, SUITE 420
WARREN, MI 48093-6726
(586) 574-4612
www.cityofwarren.org

To: Craig Treppa
From: Shumon Hakim
Date: May 6, 2024

Re: Proofpoint Email Security Suite

For the last few months, our email server has been hit hard with spam and phishing attempts. Microsoft offers basic protection that does not provide the protection we need. Email security suites can help protect email accounts and communications from unauthorized access, loss, or compromise. They can help detect and resolve email threats such as phishing or spoofing, which can lead to breaches and the risk of malware or other harmful computer viruses.

I am requesting the purchase of Proofpoint Email Security Suite. Proofpoint is the leader in enterprise level email security. For the past 6 years they have been rated in the top 3 on Gartner's magic quadrant, a resource most of the IT industry use to measure performance and viability of a vendor. The vendor I recommend for the purchase is Govconnection. Purchases from Govconnection are subject to the terms and conditions of our Sourcewell contract #121923.

Price: \$36,346.31 per year (3-year price fix)

Funding account number: 101-1258-98001

Thank you for your assistance in the matter.

A handwritten signature in black ink, appearing to read "Shumon Hakim". The signature is fluid and cursive, with a long horizontal stroke at the end.

Shumon Hakim
Information Systems Manager

RESOLUTION

Document No: TRI-W-1215

Product or Service: Proofpoint Email Security Editing Suite and Support Services

Requesting Department: I.S.

At a Regular Meeting of the City Council of the City of Warren, County of Macomb, Michigan, held on _____, 2024 at 7 p.m. Local Time, in the Council Chamber at the Warren Community Center Auditorium, 5460 Arden, Warren, Michigan.

PRESENT: Councilmembers: _____

ABSENT: Councilmembers: _____

The following preamble and resolution were offered by Councilmember _____ and supported by Councilmember _____.

Pursuant to Section 2-344 of the Code of Ordinances, the City may either participate in, sponsor, conduct, or administer a cooperative purchasing agreement for the procurement of any supplies, equipment, goods or services with one (1) or more public procurement units.

Upon performing a diligent inquiry, the I.S. Manager has determined that it is necessary in the best interest of the I.S. Department and the City, to acquire Proofpoint Email Security Suite and Support Services pursuant to cooperative purchasing.

The purchase will be made from GovConnection, Inc., 732 Milford Road, Merrimack, NH 03054 utilizing the Sourcewell Cooperative Contract #121923 in a total amount of \$109,038.93 (\$36,346.31 annually) for a three year period.

The purchasing agent has conducted a review and concurs with the cooperative purchasing.

Funds are available in Account: 101-1258-98001.

IT IS RESOLVED, that the purchase of Proofpoint Email Security Suite, utilizing the Sourcewell Cooperative Contract #121923 in an amount of \$109,038.93 (\$36,346.31 annually), for a three year period, is hereby accepted by City Council.

IT IS FURTHER RESOLVED, that the award shall commence upon successful completion of a trial period and activation of the Proofpoint Email Security Suite.

IT IS FURTHER RESOLVED, that the Purchasing Agent and/or Mayor and City Clerk are authorized to execute any such documents that are necessary for this approval consistent with the terms of the:

- Cooperative Bid Document
- Contract (Sourcewell)
- Resolution

and in such form that meets with the satisfaction of the City Attorney if review is required.

AYES: Councilmembers: _____

NAYS: Councilmembers: _____

RESOLUTION DECLARED ADOPTED this _____ day of _____, 2024.

Mindy Moore
Secretary of the Council

CERTIFICATION

STATE OF MICHIGAN)
) SS.
COUNTY OF MACOMB)

I, Sonja Buffa, duly elected City Clerk for the City of Warren, Macomb County, Michigan, hereby certifies that the foregoing is a true and correct copy of the resolution adopted by the Council of the City of Warren at its meeting held on _____, 2024.

Sonja Buffa
City Clerk



CITY CONTROLLER'S OFFICE

ONE CITY SQUARE, SUITE 425

WARREN, MI 48093-5289

(586) 574-4600

FAX (586) 574-4614

www.cityofwarren.org

DATE: MAY 7, 2024

TO: MINDY MOORE, SECRETARY, WARREN CITY COUNCIL

SUBJECT: FILE TRI-W-1223 - PURCHASE FITNESS CENTER EQUIPMENT UTILIZING THE SOURCEWELL COOPERATIVE CONTRACT #081120

The Purchasing Division concurs with the Parks and Recreation (P&R) Department and recommends that City Council award the purchase of Fitness Equipment to Fitness Things, Inc., 35539 Schoolcraft Road, Livonia, MI 48150, utilizing the Sourcewell Cooperative Contract #081120 in a total amount of \$30,999.48 when factoring in trade-in amounts offered by Fitness Things (see pricing summary below).

QUOTE #	DESCRIPTION	QTY.	NET COST	TRADE-IN	TOTAL COST
29950	Dumbbells & Kettlebells	Lot	\$ 2,425.23	(\$ 192.50)	\$ 2,232.73
29951	Treadmills	5 Each	\$ 31,266.75	(\$ 2,500.00)	\$ 28,766.75
TOTALS:			\$ 33,691.98	(\$ 2,692.50)	\$ 30,999.48

The P&R Department is seeking to purchase new treadmills (qty. 5), kettlebells (qty. 9), and dumbbells (qty. 11) while trading in some of its older equipment (550lbs of dumbbells and five treadmills) from Fitness Things, Inc. in order to best meet the needs of the WCC patrons.

The City has used Fitness Things, Inc. for many years and had success with their products and services.

Funds are available in the following Account: 208-9208-98411.

Respectfully Submitted,

Craig Treppa
Purchasing Agent

Approved By:	Signature	Date
Budget Director:		5/20/2024
Controller:		5/20/2024
MAYOR:		5/21/2024



Solicitation Number: RFP #081120

CONTRACT

This Contract is between Sourcewell, 202 12th Street Northeast, P.O. Box 219, Staples, MN 56479 (Sourcewell) and Life Fitness LLC, 9525 Bryn Mawr Ave., Rosemont, IL 60018 (Vendor).

Sourcewell is a State of Minnesota local government agency and service cooperative created under the laws of the State of Minnesota (Minnesota Statutes Section 123A.21) that offers cooperative procurement solutions to government entities. Participation is open to federal, state/province, and municipal governmental entities, higher education, K-12 education, nonprofit, tribal government, and other public entities located in the United States and Canada.

Vendor desires to contract with Sourcewell to provide equipment, products, or services to Sourcewell and the entities that access Sourcewell's cooperative purchasing contracts (Participating Entities).

1. TERM OF CONTRACT

- A. **EFFECTIVE DATE.** This Contract is effective upon the date of the final signature below.
- B. **EXPIRATION DATE AND EXTENSION.** This Contract expires October 1, 2024, unless it is cancelled sooner pursuant to Article 24. This Contract may be extended up to one additional one-year period upon request of Sourcewell and with written agreement by Vendor.
- C. **SURVIVAL OF TERMS.** Articles 11 through 16 survive the expiration or cancellation of this Contract.

2. EQUIPMENT, PRODUCTS, OR SERVICES

- A. **EQUIPMENT, PRODUCTS, OR SERVICES.** Vendor will provide the Equipment, Products, or Services as stated in its Proposal submitted under the Solicitation Number listed above. Vendor's Equipment, Products, or Services Proposal (Proposal) is attached and incorporated into this Contract.

All Equipment and Products provided under this Contract must be new/current model. Vendor may offer close-out or refurbished Equipment or Products if they are clearly indicated in



Fitness Things
 35539 Schoolcraft Rd.
 Livonia MI 48150
 United States

The Single Source Solution for
 Fitness Equipment, Delivery,
 Installation, and Service

Warren Community Center
 5460 Arden
 Warren MI 48092
 United States

Quotation # 29950

Quotation Date:
 04/29/2024

Expiration:
 05/06/2024

Salesperson:
 Jason Swekel 734-934-2859

Description	Quantity	Unit Price	Taxes	Amount
[TSD-005-050R] USA Troy 12-Sided Rubber Encased Dumbbell 5-50 Lbs Set (5 Lb Increments)	1.000 Unit(s)	1,338.00	Government	\$ 1,338.00
[TSD-005R] USA Troy 5 Lb 12-Sided Rubber Encased Dumbbell	2.000 Unit(s)	14.57	Government	\$ 29.14
[TSD-010R] USA Troy 10 Lb 12-Sided Rubber Encased Dumbbell	2.000 Unit(s)	27.99	Government	\$ 55.98
[TSD-015R] USA Troy 15 Lb 12-Sided Rubber Encased Dumbbell	2.000 Unit(s)	38.42	Government	\$ 76.84
[TSD-020R] USA Troy 20 Lb 12-Sided Rubber Encased Dumbbell	2.000 Unit(s)	51.20	Government	\$ 102.40
[TSD-025R] USA Troy 25 Lb 12-Sided Rubber Encased Dumbbell	2.000 Unit(s)	64.02	Government	\$ 128.04
[CKB-015] USA VTX 15 Lb Troy Rubber Club Kettlebell	1.000 Unit(s)	26.55	Government	\$ 26.55
[CKB-010] USA VTX 10 Lb Troy Rubber Club Kettlebell	1.000 Unit(s)	17.70	Government	\$ 17.70
[CKB-020] USA VTX 20 Lb Troy Rubber Club Kettlebell	1.000 Unit(s)	35.39	Government	\$ 35.39
[CKB-025] USA VTX 25 Lb Troy Rubber Club Kettlebell	1.000 Unit(s)	44.24	Government	\$ 44.24
[CKB-030] USA VTX 30 Lb Troy Rubber Club Kettlebell	1.000 Unit(s)	53.09	Government	\$ 53.09
[CKB-035] USA VTX 35 Lb Troy Rubber Club Kettlebell	1.000 Unit(s)	61.95	Government	\$ 61.95

All credit cards may be subject to a 3% fee. Terms are available with the completion of a credit application and approved credit terms. Change orders or returns may result in a restocking fee of up to 25%. Price are subject to change



Fitness Things
 35539 Schoolcraft Rd.
 Livonia MI 48150
 United States

The Single Source Solution for
 Fitness Equipment, Delivery,
 Installation, and Service

[CKB-040] USA VTX 40 Lb Troy Rubber Club Kettlebell	1.000	70.79	Government	\$ 70.79
	Unit(s)			
[CKB-045] USA VTX 45 Lb Troy Rubber Club Kettlebell	1.000	79.64	Government	\$ 79.64
	Unit(s)			
[CKB-050] USA VTX 50 Lb Troy Rubber Club Kettlebell	1.000	88.48	Government	\$ 88.48
	Unit(s)			
FREIGHT, DELIVERY, AND INSTALLATION				
[Freight-Equipment] Freight-Equipment	1.000	120.00	Government	\$ 120.00
	Unit(s)			
[Commercial Installation] Commercial Installation (2 man/hr)	1.000	97.00	Government	\$ 97.00
	Hour(s)			
			Subtotal	\$ 217.00
TRADE-IN				
[TRADE IN] TRADE IN - Existing dumbbells - 5-50 @.35 / lb.	1.000	-192.50	Government	\$ -192.50
	Unit(s)			
			Subtotal	\$ -192.50

Untaxed Amount	\$ 2,232.73
Taxes	\$ 0.00
Total	\$ 2,232.73

Payment terms: 30 Net Days

All credit cards may be subject to a 3% fee. Terms are available with the completion of a credit application and approved credit terms. Change orders or returns may result in a restocking fee of up to 25%. Price are subject to change



Fitness Things
 35539 Schoolcraft Rd.
 Livonia MI 48150
 United States

The Single Source Solution for
 Fitness Equipment, Delivery,
 Installation, and Service

Warren Community Center
 5460 Arden
 Warren MI 48092
 United States

Quotation # 29951

Quotation Date:
 04/29/2024

Expiration:
 05/06/2024

Salesperson:
 Jason Swekel 734-934-2859

Description	Quantity	Unit Price	Taxes	Amount
<i>Lifefitness Cardio Products - Life Fitness #081120-LFF Sourcewell Pricing</i>				
[ASPT-SL-ALLXN-13] Life Fitness Aspire Treadmill w/SL Console	5.000 Unit(s)	5,849.35	Government	\$ 29,246.75
[INTEGRATED-RECVR-02] Life Fitness Integrity Mye Receiver (1 Per Console) - SI Console Only	3.000 Unit(s)	220.00	Government	\$ 660.00
[SL-MYE-BRACKET] Life Fitness Integrity Mye Receiver Bracket (1 Per Console) - SI Console Only	3.000 Unit(s)	19.00	Government	\$ 57.00
FREIGHT, DELIVERY, AND INSTALLATION				
[Freight-Equipment] Freight-Equipment	1.000 Unit(s)	478.00	Government	\$ 478.00
[Commercial Installation] Commercial Installation (2 man/hr)	1.000 Hour(s)	825.00	Government	\$ 825.00
Subtotal				\$ 1,303.00
TRADE-IN				
[TRADE IN] TRADE IN - MATRIX T5 TREADMILLS	5.000 Unit(s)	-500.00	Government	\$ -2,500.00
Subtotal				\$ -2,500.00
Untaxed Amount				\$ 28,766.75
Taxes				\$ 0.00
Total				\$ 28,766.75

Payment terms: 30 Net Days

All credit cards may be subject to a 3% fee. Terms are available with the completion of a credit application and approved credit terms. Change orders or returns may result in a restocking fee of up to 25%. Price are subject to change



April 30, 2024

PARKS AND RECREATION

5460 ARDEN
WARREN, MI 48093
(586) 268-8400

www.cityofwarren.org

Craig Treppa
City of Warren
One City Square
Suite 425
Warren, MI. 48093

Re: Fitness Center Equipment

Dear Mr. Treppa,

The Parks & Recreation Department is requesting to purchase 5 new treadmills for the Warren Community Center. The new treadmills will be replacing old treadmills. The Parks & Recreation Department will trade in the old equipment with new and updated fitness equipment to best suit the needs of the residents of Warren. The Department was diligent on searching for the proper type and manufacturer of this equipment. Attached is quote #29951 for a cost of \$28,766.75.

The Parks & Recreation Department would also like to purchase weights and kettlebells to replace the old equipment. Attached is quote #29950 for a cost of \$2,232.73.

The City relied on Sourcewell bid #081120-LFF for pricing. The funding for this new equipment is budgeted and is available in account #9208-98411.

The Parks & Recreation Department recommends awarding the attached bid to Fitness Things Inc., 35539 Schoolcraft Road, Livonia, MI 48150. The bid price of this equipment is \$30,999.48. The specifications of the equipment, the Sourcewell contract and bid is attached.

If you have any questions or require any additional information, please contact me.

Sincerely,

A handwritten signature in black ink that reads "Anthony Casasanta".

Anthony Casasanta,
Acting Director, Parks & Recreation

RESOLUTION

Document No: TRI-W-1223
Product or Service: Fitness Equipment
Requesting Department: Parks & Recreation

At a Regular Meeting of the City Council of the City of Warren, County of Macomb, Michigan, held on _____ 2024 at 7 p.m. Local Time, in the Council Chamber at the Warren Community Center Auditorium, 5460 Arden, Warren, Michigan.

PRESENT: Councilmembers: _____

ABSENT: Councilmembers: _____

The following preamble and resolution were offered by Councilmember _____ and supported by Councilmember _____.

Pursuant to Section 2-344 of the Code of Ordinances, the City may either participate in, sponsor, conduct, or administer a cooperative purchasing agreement for the procurement of any supplies, equipment, goods or services with one (1) or more public procurement units.

Upon performing a diligent inquiry, the Acting Parks and Recreation (P&R) Director has determined that it is necessary in the interest of the P&R Department and the City, to acquire supplies, equipment, or goods pursuant to cooperative purchasing and through a cooperative purchase.

The P&R Department recommends awarding the purchase of Dumbbells, Kettlebells, and Treadmills to Fitness Equipment, Inc., 35539 Schoolcraft Road, Livonia, 48150, utilizing the Sourcwell Cooperative Contract #081120, in a total amount of \$30,999.48 when factoring in trade-in amounts offered by Fitness Things, Inc. (see pricing summary below):

QUOTE #	DESCRIPTION	QTY.	NET COST	TRADE-IN	TOTAL COST
29950	Dumbbells & Kettlebells	Lot	\$ 2,425.23	(\$ 192.50)	\$ 2,232.73
29951	Treadmills	5 Each	\$ 31,266.75	(\$ 2,500.00)	\$ 28,766.75
TOTALS:			\$ 33,691.98	(\$ 2,692.50)	\$ 30,999.48

The purchasing agent has conducted a review and concurs with the cooperative purchasing.

Funds are available in the following Account: 208-9208-98411.

IT IS RESOLVED, that the purchase through Fitness Things, Inc. is hereby accepted by City Council in an amount of \$30,999.48.

IT IS FURTHER RESOLVED, that the Purchasing Agent and/or Mayor and City Clerk are authorized to execute any such documents that are necessary for this approval consistent with the terms of the:

- Cooperative Bid Documents
- Contract
- Resolution

and in such form that meets with the satisfaction of the City Attorney if review is required.

AYES: Councilmembers: _____

NAYS: Councilmembers: _____

RESOLUTION DECLARED ADOPTED this _____ day of _____, 2024.

Mindy Moore
Secretary of the Council

CERTIFICATION

STATE OF MICHIGAN)
) SS.
COUNTY OF MACOMB)

I, Sonja Buffa, duly elected City Clerk for the City of Warren, Macomb County, Michigan, hereby certifies that the foregoing is a true and correct copy of the resolution adopted by the Council of the City of Warren at its meeting held on _____, 2024.

Sonja Buffa
City Clerk



CITY CONTROLLER'S OFFICE

ONE CITY SQUARE, SUITE 425

WARREN, MI 48093-5289

(586) 574-4600

FAX (586) 574-4614

www.cityofwarren.org

DATE: MAY 7, 2024

TO: MINDY MOORE, SECRETARY, WARREN CITY COUNCIL

SUBJECT: SOL-W-1139; AWARD OF NEPTUNE WATER METERS AND REGISTERS TO SOLE SOURCE PROVIDER

The Purchasing Department concurs with the Water Division and recommends that the purchase of Neptune Water Meters and Registers be awarded to the sole distributor in the State of Michigan, Ferguson Waterworks, 24425 Schoenherr, Warren, MI 48089, for a one-year period, in an amount not to exceed \$275,000.00.

These meters, registers, and connection parts will be used to maintain the residential, commercial, and industrial water meters in the Water Distribution System for the City of Warren.

Ferguson Waterworks is the sole distributor in the State of Michigan for Neptune water meters and registers (see attached). A list of the meters and registers purchased throughout the year is attached for your review.

If approved by your honorable body, this award will commence on the June 26, 2024 or upon the official date of City Council approval, whichever occurs later and have a term of one (1) year.

All payments are to be mailed to Ferguson Waterworks, P.O. Box 802817, Chicago, IL 802817.

Funds for this purchase are available in the Water and Sewer Budget Account 592-0000-11000.

Respectfully Submitted,

Craig Treppa
Purchasing Agent

Approved By:	Signature	Date
BUDGET DIRECTOR:		5/20/24
CONTROLLER:		5/20/2024
MAYOR:		5/21/2024



Find a Sales Contact



Neptune is ready to help your water utility manage data, protect assets, and optimize operations. Contact your nearest Neptune representative today.

US

Michigan

Search

MICHIGAN



Sam Mitchell
Territory Manager

Phone: (517)420-0428
smitchell@neptuneitg.com
Service Area: Michigan, Ohio

HIDE DISTRIBUTORS

Ferguson Waterworks
Distributor

Matt Rizzo
Phone: (248) 585-3700
matt.rizzo@ferguson.com
Service Area: Michigan

Contact Us



COLUMN		
A	B	C
ITEM	DESCRIPTION	UNIT COST
NEPTUNE WATER METERS- WITH ATTACHED REGISTERS PROGRAMMED TO CODE RFMIU8IDTDI		
1	5/8" X 3/4" T-10 WATER METER PROCODER AUTO C/F 6 WHL	\$146.70
2	1" T-10 WATER METER PROCODER AUTO 3BD C/F 6 WHL	\$293.41
3	1 1/2" T-10 WATER METER PROCODER AUTO 3BD C/F 6 WHL	\$626.59
4	2" T-10 WATER METER PROCODER AUTO PIT C/F 6WHL	\$803.76
5	2" TRU/FLO COMPOUND 3BD CUFT-PIT	\$1,949.18
6	3" TRU/FLO COMPOUND 3BD CUFT-PIT	\$2,924.42
7	4" TRU/FLO COMPOUND 3BD CUFT-PIT	\$3,922.30
8	6" TRU/FLO COMPOUND 3 BD CUFT-PIT	\$6,615.54
9	8" TRU/FLO COMPOUND 3 BD CUFT-PIT (6"x8" Tru/Flo)	\$10,980.41
NEPTUNE REGISTERS- ALL PROGRAMMED TO CODE RFMIU8IDTDI		
10	5/8" T-10 REGISTER PROCODER AUTO 3BD C/F 6WHL	\$95.66
11	3/4" T-10 REGISTER PROCODER AUTO 3BD C/F 6WHL	\$95.66
12	1" T-10 REGISTER PROCODER AUTO 3BD C/F 6WHL	\$95.66
13	1 1/2" T-10 REGISTER PROCODER AUTO 3BD C/F 6WHL	\$95.66
14	2" T-10 REGISTER PROCODER AUTO 3BD C/F 6WHL	\$95.66
15	3" PIT REGISTER PROCODER AUTO 3BD C/F 6 WHL	\$114.14
16	4" PIT REGISTER PROCODER AUTO 3BD C/F 6 WHL	\$114.14
17	6" PIT REGISTER PROCODER AUTO 3BD C/F 6 WHL	\$114.14
18	8" PIT REGISTER PROCODER AUTO 3BD C/F 6 WHL	\$114.14
UME WITH REGISTERS PROGRAMMED TO CODE RFMIU8IDTDI		
19	3" UME COMPOUND TRU/FLO AUTO 3B CUFT- PIT	\$1,821.43
20	4" UME COMPOUND TRU/FLO AUTO 3B CUFT-PIT	\$2,428.57
21	6" UME TRU/FLO AUTO 3BD CUFT-PIT	\$3,642.86

COLUMN		
A	B	C
ITEM	DESCRIPTION	UNIT COST
MISC. METER ITEMS		
22	3/4" COUPLING 5/8" X 3/4" MTR SWIVEL NUT BY 3/4" MALE IRON PIPE THREAD	\$15.54
23	1" COUPLING 1" MTR SWIVEL NUT BY 1" MALE IRON PIPE THREAD	\$23.93
24	1 1/2" METER FLANGE BY 1 1/2" FEMALE IRON PIPE THREAD	\$69.17
25	2" METER FLANGE BY 2" FEMALE IRON PIPE THREAD	\$90.31
26	3" METER FLANGE	\$305.87
27	4" METER FLANGE	\$426.32
28	6" METER FLANGE	\$711.02
29	8" METER FLANGE	\$847.53
30	5/8" METER CHAMBERS	\$18.81
31	1" METER CHAMBERS	\$48.18
32	2" METER CHAMBERS	\$141.04
33	TRIMBLE NOMAD 900B	N/A
34	TRIMBLE NOMAD 900B CHARGER & CABLES	N/A
35	2" THRU 4" METER TESTING AT DESIGNATED LOCATION	N/A
36	6" THRU 8" METER TESTING AT DESIGNATED LOCATION	N/A
37	10" THRU 12" METER TESTING AT DESIGNATED LOCATION	N/A

NEPTUNE MACH 10 ULTRASONIC METER		
METER SIZE - LENGTH - HEIGHT		
38	5/8" x 7 1/2" x 3 3/16"	\$235.04
39	5/8" x 3/4" x 7 1/2" x 3 3/16"	\$235.04
40	1" x 10 3/4" x 3 11/16"	\$321.90
41	1 1/2" x 10" x 6 1/4"	\$829.93
42	1 1/2" x 13" x 6 1/4"	\$829.93
43	1 1/2" x 12 5/8" x 6 1/4"	\$829.93
44	2" x 10" x 6 1/2"	\$837.97

COLUMN		
A	B	C
ITEM	DESCRIPTION	UNIT COST
45	2" x 15 1/2" x 6 1/2"	\$837.97
46	2" x 17" x 6 1/2"	\$837.97
METER SIZE - LENGTH - HEIGHT		
47	2" x 15 1/4" x 6 1/2"	\$837.97
48	3" x 12" x 9.5"	\$2,479.26
49	3" x 17" x 9.5"	\$2,535.81
50	4" x 14" x 11"	\$3,199.26
51	4" x 20" x 11"	\$3,302.64
52	6" x 18" x 12 3/4"	\$6,008.78
53	6" x 24" x 12 3/4"	\$6,100.68
54	8" x 20" x 15 3/5"	\$9,258.78
55	10" x 26" x 17 9/10"	\$11,566.89
56	12" x 19 7/10" x 20"	\$13,479.05



Water Division
12821 Stephens Road
Warren, MI 48089
(586) 759-9200

David Koss
Deputy Superintendent

May 7, 2024

Craig Treppa, Purchasing Agent
Purchasing Division of the City of Warren

Re: SOL-W-1139 – Neptune Water Meters

Dear Mr. Treppa:

The Water Division is recommending the award of sole source contract to Ferguson Waterworks to purchase Neptune water meters and meter components at an estimated cost not to exceed \$275,000 for a one-year period. The bid summary attached represents a list of meter type, sizes and appurtenances that the Department may need on an annual basis. We are requesting council to approve up to \$275,000 as we anticipate the continuance of repair and/or replacement of large meters in the next year.

This bid as presented will maintain the required residential, commercial and industrial water meters and connection parts as required in the Water Distribution System in the City of Warren. Funds are available in the Water and Sewer System Meter inventory account #592-0000-11000.

I will be available to City Council for any questions they may have in regards to this proposal. I can be reached at my office at 586.759.9224 or my cell at 586.610.1031.

If you concur with my recommendations, please forward to the Mayor and City Council for approval.

Sincerely,

A handwritten signature in black ink, appearing to read "DKoss".

David Koss, Deputy Superintendent
City of Warren Water Division

cc: David Muzzarelli

RESOLUTION

Document No: SOL-W-1139
Product or Service: Neptune Water Meters & Registers
Requesting Department: Water

At a Regular Meeting of the City Council of the City of Warren, County of Macomb, Michigan, held on _____, 2024 at 7 p.m. Local Time, in the Council Chamber at the Warren Community Center Auditorium, 5460 Arden, Warren, Michigan.

PRESENT: Councilmembers: _____

ABSENT: Councilmembers: _____

The following preamble and resolution were offered by Councilmember _____ and supported by Councilmember _____.

Upon performing a diligent inquiry, the Water Division Superintendent has determined that it is necessary in the interests of the Water Division and the City, to acquire Neptune water meters and registers from the sole authorized distributor in the State of Michigan.

Ferguson Waterworks, 24425 Schoenherr, Warren MI 48089 is the sole source distributor in the State of Michigan for Neptune water meters and registers.

The Purchasing Agent has conducted a review and concurs with the sole procurement.

Funds are available annually in the following account:

Water and Sewer System Meter Inventory Account: 592-0000-11000.

All payments are to be mailed to Ferguson Waterworks, P.O. Box 802817, Chicago, IL 802817.

IT IS RESOLVED, that the sole source purchase through Ferguson Waterworks is hereby accepted by City Council for a one-year period in an amount not to exceed \$275,000.00.

IT IS FURTHER RESOLVED, that the award shall commence on June 26, 2024 or upon the official date of City Council approval, whichever occurs later.

IT IS FURTHER RESOLVED, that the Purchasing Agent and/or Mayor and City Clerk are authorized to execute any such documents that are necessary for this approval consistent with the terms of the:

- Contract
- Resolution

and in such form that meets with the satisfaction of the City Attorney if review is required.

AYES: Councilmembers: _____

NAYS: Councilmembers: _____

RESOLUTION DECLARED ADOPTED this _____ day of _____, 2024.

Mindy Moore
Secretary of the Council



CITY CONTROLLER'S OFFICE

ONE CITY SQUARE, SUITE 425

WARREN, MI 48093-5289

(586) 574-4600

FAX (586) 574-4614

www.cityofwarren.org

DATE: MAY 20, 2024
TO: MINDY MOORE, SECRETARY OF WARREN CITY COUNCIL
SUBJECT: AWARD OF BID ITB-W-1197 FOR THE PURCHASE OF COPPER WATER SUPPLY PARTS

The Purchasing Division concurs with the Water Division and recommends that Bid ITB-W-1197, for furnishing Copper Water Supply Parts for a one (1) year period, with the option to renew for one (1) additional one-year period, with mutual consent of both parties, be awarded to the low-responsible and cost-effective bidder, Core & Main LP, 6575 23 Mile Road, Shelby Township, MI 48316, in an annual amount not to exceed \$119,330.05.

On April 24, 2024, at 1:00 PM electronic bids for ITB-W-1197; To Furnish Copper Water Supply parts to the Water Division were publicly opened. Bids were solicited through the BidNet® (MITN) procurement system. Four (4) vendors responded with bids, which are summarized on the attached bid tabulation sheets submitted for your review.

The Water Division will utilize this bid to assist in maintaining all required water service connection accessories in the Water Division System.

If approved by your honorable body, the award will commence on the official date of City Council approval or June 15, 2024, whichever occurs later, and shall have a term of one (1) year. There is an option to renew the award for one (1) additional one-year period, with mutual consent of both parties.

Funds are available in Water Maintenance Inventory Account: 592-0000-11100.

Respectfully Submitted,

Craig Treppa
Purchasing Agent

Approved By:	Signature	Date
Budget Director:		5/20/2024
Controller		5/22/2024
MAYOR:		5/22/24

AS-READ BID SUMMARY

City of Warren
1 City Square
Warren MI 48093

BID: ITB-W-1197
Bid Opening Date: 4/24/2024
Department: WATER

PRODUCT OR SERVICE: COPPER WATER SUPPLY PARTS

BIDDER	GRAND TOTAL
CORE AND MAIN, LP	\$ 119,330.05
ETNA SUPPLY COMPANY	\$ 131,328.90
FERGUSON WATER WORKS	\$ 122,896.00
PROGRESSIVE PLUMBING SUPPLY	NOT SIGNED, THEREFORE, NOT ACCEPTED

ITEM	DESCRIPTION	BRAND	EST. QTY./YEAR	U/M	UNIT PRICE	EXTENDED PRICE
1	3/4" K Copper Tubing (100' Rolls)	Any	1500	Feet	\$ 5.80	\$ 8,700.00
2	1" K Copper Tubing (100' Rolls)	Any	1500	Feet	\$ 7.70	\$ 11,550.00
3	3/4" Curb Valve - 6104 Min Ball VLV FLR X FLR	A.Y. McDonald	200	Each	\$ 76.96	\$ 15,392.00
4	1" Curb Valve - 6104 Min Ball VLV FLR X FLR	A.Y. McDonald	50	Each	\$ 103.86	\$ 5,193.00
5	1 1/2" Curb Valve - 6104 Min Ball VLV FLR X FLR	A.Y. McDonald	15	Each	\$ 244.06	\$ 3,660.90
6	2" Curb Valve - 6104 Min Ball VLV FLR X FLR	A.Y. McDonald	12	Each	\$ 394.83	\$ 4,737.96
7	3/4" Corp Valves - 4701 Corp AWWA CC X FLR	A.Y. McDonald	150	Each	\$ 31.98	\$ 4,797.00
8	1" Corp Valves - 4701 Corp AWWA CC X FLR	A.Y. McDonald	35	Each	\$ 48.88	\$ 1,710.80
9	1 1/2" Corp Valves - 4701 Corp AWWA CC X FLR	A.Y. McDonald	15	Each	\$ 149.94	\$ 2,249.10
10	2" Corp Valves - 4701 Corp AWWA CC X FLR	A.Y. McDonald	12	Each	\$ 261.92	\$ 3,143.04
11	3/4" Union 3PT FLR X FLR MC - 4758	A.Y. McDonald	100	Each	\$ 17.70	\$ 1,770.00
12	3/4" Lead to Copper unions Compression	A.Y. McDonald	50	Each	\$ 36.25	\$ 1,812.50
13	LF 3/4 CTS X CTS COMP COUP	A.Y. McDonald	10	Each	\$ 19.20	\$ 192.00
14	LF 1 CTS X CTS COMP COUP	A.Y. McDonald	20	Each	\$ 21.96	\$ 439.20
15	LF 1-1/2 CTS X CTS COMP COUP	A.Y. McDonald	10	Each	\$ 73.48	\$ 734.80
16	LF 2 CTS X CTS COMP COUP	A.Y. McDonald	10	Each	\$ 99.23	\$ 992.30
17	LF 3/4 CC X CTS PJ BALL CORP	A.Y. McDonald	10	Each	\$ 50.87	\$ 508.70
18	LF 1 CC X CTS PJ BALL CORP	A.Y. McDonald	10	Each	\$ 66.90	\$ 669.00
19	LF 1-1/2 CC X CTS PJ BALL CORP	A.Y. McDonald	10	Each	\$ 149.94	\$ 1,499.40
20	LF 2 CC X CTS PJ BALL CORP	A.Y. McDonald	10	Each	\$ 248.00	\$ 2,480.00
21	LF 3/4 CTS X CTS BALL CURB ST	A.Y. McDonald	10	Each	\$ 76.10	\$ 761.00
22	LF 1 CTS X CTS BALL CURB ST	A.Y. McDonald	15	Each	\$ 111.12	\$ 1,666.80
23	LF 1-1/2 CTS X CTS PJ BALL CURB VLV	A.Y. McDonald	10	Each	\$ 257.83	\$ 2,578.30
24	LF 2 CTS X CTS PJ BALL CURB VLV	A.Y. McDonald	10	Each	\$ 359.53	\$ 3,595.30
25	3/4 CTS PET / HDPE DR9 INS STFNR	A.Y. McDonald	20	Each	\$ 2.07	\$ 41.40

ITEM	DESCRIPTION	BRAND	EST. QTY./YEAR	U/M	UNIT PRICE	EXTENDED PRICE
26	1 CTS PET / HDPE DR9 INS STFNR	A.Y. McDonald	20	Each	\$ 2.20	\$ 44.00
27	1-1/2 CTS PET INS STFNR	A.Y. McDonald	20	Each	\$ 3.03	\$ 60.60
28	2 CTS PET INS STFNR	A.Y. McDonald	10	Each	\$ 3.03	\$ 30.30
29	12GA 30MM 1000 FT COP TRCR WIRE BLU	A.Y. McDonald	3	Each	\$ 210.00	\$ 630.00
30	3/4" CTS 250 PSI NSF BLUE SDR9	A.Y. McDonald	100	Per ft	\$ 0.35	\$ 35.00
31	1" CTS 250 PSI NSF BLUE SDR9	A.Y. McDonald	900	Per ft	\$ 0.57	\$ 513.00
32	1-1/2" CTS 250 PSI NSF BLUE SDR9	A.Y. McDonald	900	Per ft	\$ 1.18	\$ 1,062.00
33	2" CTS 250 PSI NSF BLUE SDR9	A.Y. McDonald	900	Per ft	\$ 2.03	\$ 1,827.00
34	1" Union 3PT FLR X FLR MC- 4758	A.Y. McDonald	75	Each	\$ 31.03	\$ 2,327.25
35	1 1/2" Union 3PT FLR X FLR MC- 4758	A.Y. McDonald	10	Each	\$ 93.09	\$ 930.90
36	2" Union 3PT FLR X FLR MC- 4758	A.Y. McDonald	10	Each	\$ 151.89	\$ 1,518.90
37	3/4" Brass Plus - 73206 CC Plug	A.Y. McDonald	10	Each	\$ 10.17	\$ 101.70
38	1" Brass Plus - 73206 CC Plug	A.Y. McDonald	10	Each	\$ 14.78	\$ 147.80
39	1" to 3/4" Reducer Bushing - 747011 AWWA X AWWA Bushing	A.Y. McDonald	25	Each	\$ 16.65	\$ 416.25
40	1 1/4" x 5'6" Curb Box with Bushing - 5615WB-curb box rod not needed	A.Y. McDonald	275	Each	\$ 60.72	\$ 16,698.00
41	2" x 5'6" Curb Box with Bushing - 5624-curb box rod not needed	Mueller H-10304	50	Each	\$ 114.19	\$ 5,709.50
42	1 1/4" Stop Box Cap with Pentagon Plug - 5614L	A.Y. McDonald	120	Each	\$ 14.88	\$ 1,785.60
43	1 1/2" Stop Box Cap with Pentagon Plug - 5623L	A.Y. McDonald	50	Each	\$ 13.05	\$ 652.50
44	2" Stop Box Cap with Pentagon Plug - 5624L	A.Y. McDonald	50	Each	\$ 22.15	\$ 1,107.50
45	1 1/4" Pentagon Plug - 5614BP	A.Y. McDonald	125	Each	\$ 3.95	\$ 493.75
46	3/4" FLR x 1" COMP (CTS)	A.Y. McDonald	50	Each	\$ 20.91	\$ 1,045.50
47	1" FLR x 1" COMP (CTS)	A.Y. McDonald	50	Each	\$ 26.37	\$ 1,318.50
GRAND TOTAL:						\$ 119,330.05

Core and Main bid the following exceptions: Due to the current extreme volatility in the copper market, pricing for line items #1-2 are good for 30 days, after which new pricing will need to be obtained. -Item #41 is Mueller brand, H-10304, as AYM no longer makes the requested curb box. Spec sheet is attached.

ITEM	DESCRIPTION	BRAND	EST. QTY./YEAR	U/M	UNIT PRICE	EXTENDED PRICE
1	¾" K Copper Tubing (100' Rolls)	Any	1500	Feet	\$ 6.05	\$ 9,075.00
2	1" K Copper Tubing (100' Rolls)	Any	1500	Feet	\$ 8.03	\$ 12,045.00
3	¾" Curb Valve - 6104 Min Ball VLV FLR X FLR	Ford Meter Box	200	Each	\$ 80.00	\$ 16,000.00
4	1" Curb Valve - 6104 Min Ball VLV FLR X FLR	Ford Meter Box	50	Each	\$ 108.50	\$ 5,425.00
5	1 ½" Curb Valve - 6104 Min Ball VLV FLR X FLR	Ford Meter Box	15	Each	\$ 255.00	\$ 3,825.00
6	2" Curb Valve - 6104 Min Ball VLV FLR X FLR	Ford Meter Box	12	Each	\$ 412.50	\$ 4,950.00
7	¾" Corp Valves - 4701 Corp AWWA CC X FLR	Ford Meter Box	150	Each	\$ 33.40	\$ 5,010.00
8	1" Corp Valves - 4701 Corp AWWA CC X FLR	Ford Meter Box	35	Each	\$ 51.05	\$ 1,786.75
9	1 ½" Corp Valves - 4701 Corp AWWA CC X FLR	Ford Meter Box	15	Each	\$ 156.65	\$ 2,349.75
10	2" Corp Valves - 4701 Corp AWWA CC X FLR	Ford Meter Box	12	Each	\$ 273.70	\$ 3,284.40
11	¾" Union 3PT FLR X FLR MC - 4758	Ford Meter Box	100	Each	\$ 18.50	\$ 1,850.00
12	¾" Lead to Copper unions Compression	Ford Meter Box	50	Each	\$ 37.00	\$ 1,850.00
13	LF ¾ CTS X CTS COMP COUP	Ford Meter Box	10	Each	\$ 20.05	\$ 200.50
14	LF 1 CTS X CTS COMP COUP	Ford Meter Box	20	Each	\$ 22.95	\$ 459.00
15	LF 1-1/2 CTS X CTS COMP COUP	Ford Meter Box	10	Each	\$ 76.80	\$ 768.00
16	LF 2 CTS X CTS COMP COUP	Ford Meter Box	10	Each	\$ 103.65	\$ 1,036.50
17	LF ¾ CC X CTS PJ BALL CORP	Ford Meter Box	10	Each	\$ 53.15	\$ 531.50
18	LF 1 CC X CTS PJ BALL CORP	Ford Meter Box	10	Each	\$ 59.90	\$ 599.00
19	LF 1-1/2 CC X CTS PJ BALL CORP	Ford Meter Box	10	Each	\$ 156.65	\$ 1,566.50
20	LF 2 CC X CTS PJ BALL CORP	Ford Meter Box	10	Each	\$ 259.10	\$ 2,591.00
21	LF ¾ CTS X CTS BALL CURB ST	Ford Meter Box	10	Each	\$ 72.75	\$ 727.50
22	LF 1 CTS X CTS BALL CURB ST	Ford Meter Box	15	Each	\$ 109.40	\$ 1,641.00
23	LF 1-1/2 CTS X CTS PJ BALL CURB VLV	Ford Meter Box	10	Each	\$ 261.75	\$ 2,617.50
24	LF 2 CTS X CTS PJ BALL CURB VLV	Ford Meter Box	10	Each	\$ 268.00	\$ 2,680.00
25	¾ CTS PET / HDPE DR9 INS STFNR	Ford Meter Box	20	Each	\$ 2.70	\$ 54.00

ITEM	DESCRIPTION	BRAND	EST. QTY./YEAR	U/M	UNIT PRICE	EXTENDED PRICE
26	1 CTS PET / HDPE DR9 INS STFNR	Ford Meter Box	20	Each	\$ 2.70	\$ 54.00
27	1-1/2 CTS PET INS STFNR	Ford Meter Box	20	Each	\$ 4.10	\$ 82.00
28	2 CTS PET INS STFNR	Ford Meter Box	10	Each	\$ 4.10	\$ 41.00
29	12GA 30MM 1000 FT COP TRCR WIRE BLU	Ford Meter Box	3	Each	\$ 250.00	\$ 750.00
30	3/4" CTS 250 PSI NSF BLUE SDR9	Ford Meter Box	100	Per ft	\$ 0.30	\$ 30.00
31	1" CTS 250 PSI NSF BLUE SDR9	Ford Meter Box	900	Per ft	\$ 0.48	\$ 432.00
32	1-1/2" CTS 250 PSI NSF BLUE SDR9	Ford Meter Box	900	Per ft	\$ 1.03	\$ 927.00
33	2" CTS 250 PSI NSF BLUE SDR9	Ford Meter Box	900	Per ft	\$ 1.74	\$ 1,566.00
34	1" Union 3PT FLR X FLR MC- 4758	Ford Meter Box	75	Each	\$ 32.35	\$ 2,426.25
35	1 1/2" Union 3PT FLR X FLR MC- 4758	Ford Meter Box	10	Each	\$ 97.25	\$ 972.50
36	2" Union 3PT FLR X FLR MC- 4758	Ford Meter Box	10	Each	\$ 158.70	\$ 1,587.00
37	3/4" Brass Plus - 73206 CC Plug	Ford Meter Box	10	Each	\$ 8.40	\$ 84.00
38	1" Brass Plus - 73206 CC Plug	Ford Meter Box	10	Each	\$ 12.30	\$ 123.00
39	1" to 3/4" Reducer Bushing - 747011 AWWA X AWWA Bushing	Ford Meter Box	25	Each	\$ 13.85	\$ 346.25
40	1 1/2" x 5'6" Curb Box with Bushing - 5615WB-curb box rod not needed	Ford Meter Box	275	Each	\$ 101.00	\$ 27,775.00
41	2" x 5'6" Curb Box with Bushing - 5624-curb box rod not needed	Ford Meter Box	50	Each	\$ 57.00	\$ 2,850.00
42	1 1/4" Stop Box Cap with Pentagon Plug - 5614L	Ford Meter Box	120	Each	\$ 15.50	\$ 1,860.00
43	1 1/2" Stop Box Cap with Pentagon Plug - 5623L	Ford Meter Box	50	Each	\$ 13.80	\$ 690.00
44	2" Stop Box Cap with Pentagon Plug - 5624L	Ford Meter Box	50	Each	\$ 23.55	\$ 1,177.50
45	1 1/4" Pentagon Plug - 5614BP	Ford Meter Box	125	Each	\$ 4.20	\$ 525.00
46	3/4" FLR x 1" COMP (CTS)	Ford Meter Box	50	Each	\$ 32.50	\$ 1,625.00
47	1" FLR x 1" COMP (CTS)	Ford Meter Box	50	Each	\$ 49.65	\$ 2,482.50
GRAND TOTAL:						\$ 131,328.90

ITEM	DESCRIPTION	BRAND	EST. QTY./YEAR	U/M	UNIT PRICE	EXTENDED PRICE
1	½" K Copper Tubing (100' Rolls)	Any	1500	Feet	\$ 6.24	\$ 9,360.00
2	1" K Copper Tubing (100' Rolls)	Any	1500	Feet	\$ 8.28	\$ 12,420.00
3	¾" Curb Valve - 6104 Min Ball VLV FLR X FLR	Ford Meter Box	200	Each	\$ 83.00	\$ 16,600.00
4	1" Curb Valve - 6104 Min Ball VLV FLR X FLR	Ford Meter Box	50	Each	\$ 112.00	\$ 5,600.00
5	1 ½" Curb Valve - 6104 Min Ball VLV FLR X FLR	Ford Meter Box	15	Each	\$ 260.00	\$ 3,900.00
6	2" Curb Valve - 6104 Min Ball VLV FLR X FLR	Ford Meter Box	12	Each	\$ 421.00	\$ 5,052.00
7	¾" Corp Valves - 4701 Corp AWWA CC X FLR	Ford Meter Box	150	Each	\$ 35.00	\$ 5,250.00
8	1" Corp Valves - 4701 Corp AWWA CC X FLR	Ford Meter Box	35	Each	\$ 53.00	\$ 1,855.00
9	1 ½" Corp Valves - 4701 Corp AWWA CC X FLR	Ford Meter Box	15	Each	\$ 160.00	\$ 2,400.00
10	2" Corp Valves - 4701 Corp AWWA CC X FLR	Ford Meter Box	12	Each	\$ 279.00	\$ 3,348.00
11	¾" Union 3PT FLR X FLR MC - 4758	Ford Meter Box	100	Each	\$ 19.00	\$ 1,900.00
12	¾" Lead to Copper unions Compression	Ford Meter Box	50	Each	\$ 39.00	\$ 1,950.00
13	LF ¾ CTS X CTS COMP COUP	Ford Meter Box	10	Each	\$ 21.00	\$ 210.00
14	LF 1 CTS X CTS COMP COUP	Ford Meter Box	20	Each	\$ 24.00	\$ 480.00
15	LF 1-1/2 CTS X CTS COMP COUP	Ford Meter Box	10	Each	\$ 79.00	\$ 790.00
16	LF 2 CTS X CTS COMP COUP	Ford Meter Box	10	Each	\$ 105.00	\$ 1,050.00
17	LF ¾ CC X CTS PJ BALL CORP	Ford Meter Box	10	Each	\$ 55.00	\$ 550.00
18	LF 1 CC X CTS PJ BALL CORP	Ford Meter Box	10	Each	\$ 72.00	\$ 720.00
19	LF 1-1/2 CC X CTS PJ BALL CORP	Ford Meter Box	10	Each	\$ 160.00	\$ 1,600.00
20	LF 2 CC X CTS PJ BALL CORP	Ford Meter Box	10	Each	\$ 265.00	\$ 2,650.00
21	LF ¾ CTS X CTS BALL CURB ST	Ford Meter Box	10	Each	\$ 75.00	\$ 750.00
22	LF 1 CTS X CTS BALL CURB ST	Ford Meter Box	15	Each	\$ 113.00	\$ 1,695.00
23	LF 1-1/2 CTS X CTS PJ BALL CURB VLV	Ford Meter Box	10	Each	\$ 269.00	\$ 2,690.00
24	LF 2 CTS X CTS PJ BALL CURB VLV	Ford Meter Box	10	Each	\$ 378.00	\$ 3,780.00
25	¾ CTS PET / HDPE DR9 INS STFNR	Ford Meter Box	20	Each	\$ 2.00	\$ 40.00

ITEM	DESCRIPTION	BRAND	EST. QTY./YEAR	U/M	UNIT PRICE	EXTENDED PRICE
26	1 CTS PET / HDPE DR9 INS STFNR	Ford Meter Box	20	Each	\$ 2.00	\$ 40.00
27	1-1/2 CTS PET INS STFNR	Ford Meter Box	20	Each	\$ 2.80	\$ 56.00
28	2 CTS PET INS STFNR	Ford Meter Box	10	Each	\$ 2.80	\$ 28.00
29	12GA 30MM 1000 FT COP TRCR WIRE BLU	Ford Meter Box	3	Each	\$ 147.00	\$ 441.00
30	3/4" CTS 250 PSI NSF BLUE SDR9	Ford Meter Box	100	Per ft	\$ 0.31	\$ 31.00
31	1" CTS 250 PSI NSF BLUE SDR9	Ford Meter Box	900	Per ft	\$ 0.75	\$ 675.00
32	1-1/2" CTS 250 PSI NSF BLUE SDR9	Ford Meter Box	900	Per ft	\$ 1.25	\$ 1,125.00
33	2" CTS 250 PSI NSF BLUE SDR9	Ford Meter Box	900	Per ft	\$ 1.75	\$ 1,575.00
34	1" Union 3PT FLR X FLR MC- 4758	Ford Meter Box	75	Each	\$ 34.00	\$ 2,550.00
35	1 1/2" Union 3PT FLR X FLR MC- 4758	Ford Meter Box	10	Each	\$ 100.00	\$ 1,000.00
36	2" Union 3PT FLR X FLR MC- 4758	Ford Meter Box	10	Each	\$ 163.00	\$ 1,630.00
37	3/4" Brass Plus - 73206 CC Plug	Ford Meter Box	10	Each	\$ 10.00	\$ 100.00
38	1" Brass Plus - 73206 CC Plug	Ford Meter Box	10	Each	\$ 14.00	\$ 140.00
39	1" to 3/4" Reducer Bushing - 747011 AWWA X AWWA Bushing	Ford Meter Box	25	Each	\$ 14.50	\$ 362.50
40	1 1/2" x 5'6" Curb Box with Bushing - 5615WB-curb box rod not needed	Ford Meter Box	275	Each	\$ 66.00	\$ 18,150.00
41	2" x 5'6" Curb Box with Bushing - 5624-curb box rod not needed	Ford Meter Box	50	Each	NO BID	NO BID
42	1 1/2" Stop Box Cap with Pentagon Plug - 5614L	Ford Meter Box	120	Each	\$ 17.00	\$ 2,040.00
43	1 1/2" Stop Box Cap with Pentagon Plug - 5623L	Ford Meter Box	50	Each	\$ 14.00	\$ 700.00
44	2" Stop Box Cap with Pentagon Plug - 5624L	Ford Meter Box	50	Each	\$ 24.00	\$ 1,200.00
45	1 1/2" Pentagon Plug - 5614BP	Ford Meter Box	125	Each	\$ 4.50	\$ 562.50
46	3/4" FLR x 1" COMP (CTS)	Ford Meter Box	50	Each	\$ 31.00	\$ 1,550.00
47	1" FLR x 1" COMP (CTS)	Ford Meter Box	50	Each	\$ 46.00	\$ 2,300.00
GRAND TOTAL:						\$ 122,896.00

Ferguson Waterworks bid the following exceptions: Line 41 AY McDonald part # 5624 has been made obsolete and they no longer make the part.



Water Division
12821 Stephens Road
Warren, MI 48089
(586) 759-9200

May 20, 2024

Craig Treppa, Purchasing Agent
Purchasing Division of the City of Warren

Re: ITB-W-1197 - Copper Water Supply Parts

Dear Mr. Treppa:

The Water Division is recommending to award this contract to Core and Main LP for the purchase of copper and brass water service accessories at an estimated cost not to exceed \$119,330.05 (See attached Bid Summary for details).

The bid as presented will maintain all required water service connection accessories in the Water Distribution System in the City of Warren. Core and Main LP has supplied and furnished water service parts in the past with exceptional service.

Funds are available in the Water and Sewer System Budget in account #592-0000-11100.

I will be available to City Council for any questions they may have in regards to this proposal. I can be reached at my office at 586.759.9224 or my cell at 586.610.1031.

If you concur with my recommendations, please forward to the Mayor and City Council for approval.

Thank you,

David Koss, Superintendent
City of Warren Water Division

RESOLUTION

Document No: ITB-W-1197
Product or Service: Copper Water Supply Parts
Requesting Department: Water Division

At a Regular Meeting of the City Council of the City of Warren, County of Macomb, Michigan, held on _____, 2024 at 7 p.m. Local Time, in the Council Chamber at the Warren Community Center Auditorium, 5460 Arden, Warren, Michigan.

PRESENT: Councilmembers: _____

ABSENT: Councilmembers: _____

The following preamble and resolution were offered by Councilmember _____ and supported by Councilmember _____.

Sealed bids were accepted, publicly opened and read on Wednesday, April, 24 2024.

The following qualified bids have been received by City Council:

<u>BIDDER:</u>	<u>AMOUNT:</u>
----------------	----------------

Please see attached bid tabulation

The bid of Core and Main LP, 6575 23 Mile Road, Shelby Township, MI 48316 has been determined to be the low responsible and cost-effective bid to furnish Copper Water Supply Parts. This contract is for a one (1) year period, which shall commence on June 15, 2024, or upon the official date of Warren City Council approval, whichever occurs later. There is an option to renew for one (1) additional one-year period, with mutual consent of both parties.

Funds are available in account number: 592-0000-11100

IT IS RESOLVED, that the bid of Core and Main LP is hereby accepted by City Council in an annual amount not to exceed \$ 119,330.05, for a one (1) year period, commencing on June 15, 2024, or upon the official date of Warren City Council approval, whichever occurs later, with an option to renew for one (1) additional one-year period, with mutual consent of both parties.

IT IS FURTHER RESOLVED, that the Purchasing Agent and/or Mayor and City Clerk are authorized to execute any such documents that are necessary for this approval consistent with the terms of the:

- Bid document
- Contract
- Resolution

and in such form that meets with the satisfaction of the City Attorney if review is required.

AYES: Councilmembers: _____

NAYS: Councilmembers: _____

RESOLUTION DECLARED ADOPTED this ____ day of _____, 2024.

Mindy Moore
Secretary of the Council



CITY CONTROLLER'S OFFICE
 ONE CITY SQUARE, SUITE 425
 WARREN, MI 48093-5289
 (586) 574-4600
 FAX (586) 574-4614
 www.cityofwarren.org

DATE: MAY 15, 2024
 TO: MINDY MOORE, SECRETARY, WARREN CITY COUNCIL
 SUBJECT: AWARD OF BID ITB-W-1194: TO REPLACE SAND FILTER VALVES AT THE WASTE WATER TREATMENT PLANT (WWTP)

The Purchasing Division concurs with the Waste Water Treatment Plant Division Head and recommends that City Council approve the award of bid ITB-W-1194; to replace sand filter valves, to the low responsible and cost-effective bidder, CSM Mechanical, Inc., 1235 Holden Avenue, Milford, MI 48381 in an amount not to exceed \$334,315.00.

On Wednesday, May 8, 2024 at 1:00 PM electronic bids were publicly opened for ITB-W-1194; To Replace Sand Filter Valves. Invitations to bid were posted on the BidNet (MITN) system. Four (4) vendors responded with a bid. All bids are summarized on the attached bid tabulation form submitted for your review.

The scope of this project includes the replacement of several valves in the WWTP Sand Filter Building that are critical to plant operations. The Waste Water Treatment Plant has utilized CSM Mechanical, Inc. for similar work in the past and has been satisfied with their service.

Funds are available in the following Account: 592-9047-98080.

Respectfully Submitted,

Craig Treppa
 Purchasing Agent

Approved By:	Signature	Date
Budget Director:		5/20/2024
Controller:		5/20/2024
MAYOR:		5/21/2024

AS-READ BID SUMMARY

City of Warren
1 City Square
Warren MI 48093

BID: ITB-W-1194
Bid Opening Date: 5/8/2024
Department: WWTP

PRODUCT OR SERVICE: SAND FILTER VALVE REPLACEMENTS

BIDDER	GRAND TOTAL
CSM MECHANICAL, LLC.	\$ 334,315.00
MIDWEST POWER SYSTEMS	\$ 376,000.00
PROCESS PIPING AND EQUIPMENT	\$ 432,500.00
WEISS CONSTRUCTION, CO., LLC.	\$ 829,230.00

ITEM	DESCRIPTION	UNITS	QTY	UNIT PRICE	AMOUNT
1	BONDS AND INSURANCE EXPENSES	LS	1	\$ 4,230.90	\$ 4,230.90
2	MOBILIZATION, DEMOBILIZATION and RESTORATION COMPLETE (Not to exceed 5% of total bid amount)	LS	1	\$ 10,934.90	\$ 10,934.90
3	FURNISH AND INSTALL 36" DEZURIK AWWA C504 BUTTERFLY VALVE OR APPROVED EQUAL	EA	2	\$ 39,015.35	\$ 78,030.70
4	FURNISH AND INSTALL 30" VAL-MATIC AWWA C504 150B BUTTERFLY VALVE OR APPROVED EQUAL	EA	1	\$ 19,195.02	\$ 19,195.02
5	FURNISH 10" VAL-MATIC SWING FLEX CHECK VALVE 510A OR APPROVED EQUAL	EA	4	\$ 2,447.75	\$ 9,791.00
6	INSTALL 10" VAL-MATIC SWING FLEX CHECK VALVE 510A OR APPROVED EQUAL	EA	2	\$ 2,016.32	\$ 4,032.64
7	FURNISH 20" DEZURIK C504 BAW BUTTERFLY VALVE WITH TW-7 PNEUMATIC CYLINDER ACTUATOR OR APPROVED EQUAL	EA	4	\$ 14,712.00	\$ 58,848.00
8	INSTALL 20" DEZURIK C504 BAW BUTTERFLY VALVE WITH TW-7 PNEUMATIC CYLINDER ACTUATOR OR APPROVED EQUAL	EA	3	\$ 6,918.40	\$ 20,755.20
9	REMOVE 12" BUTTERFLY VALVE AND REPLACE WITH 12" CAP	EA	11	\$ 1,954.24	\$ 21,496.64
10	REMOVE 20' OF 1/2" COPPER AIR LINE AND REPLACE WITH SHUT OFF VALVE	EA	12	\$ 375.00	\$ 4,500.00
11	PERMIT COSTS ALLOWANCE, CONTINGENCY ITEM	LS	1	\$ 2,500.00	\$ 2,500.00
12	UNFORESEEN SITE CONDITIONS ALLOWANCE, CONTINGENCY ITEM	LS	1	\$ 100,000.00	\$ 100,000.00
GRAND TOTAL:					\$ 334,315.00

ITEM	DESCRIPTION	UNITS	QTY	UNIT PRICE	AMOUNT
1	BONDS AND INSURANCE EXPENSES	LS	1	\$ 7,500.00	\$ 7,500.00
2	MOBILIZATION, DEMOBILIZATION and RESTORATION COMPLETE (Not to exceed 5% of total bid amount)	LS	1	\$ 7,500.00	\$ 7,500.00
3	FURNISH AND INSTALL 36" DEZURIK AWWA C504 BUTTERFLY VALVE OR APPROVED EQUAL	EA	2	\$ 55,000.00	\$ 110,000.00
4	FURNISH AND INSTALL 30" VAL-MATIC AWWA C504 150B BUTTERFLY VALVE OR APPROVED EQUAL	EA	1	\$ 26,000.00	\$ 26,000.00
5	FURNISH 10" VAL-MATIC SWING FLEX CHECK VALVE 510A OR APPROVED EQUAL	EA	4	\$ 2,500.00	\$ 10,000.00
6	INSTALL 10" VAL-MATIC SWING FLEX CHECK VALVE 510A OR APPROVED EQUAL	EA	2	\$ 3,000.00	\$ 6,000.00
7	FURNISH 20" DEZURIK C504 BAW BUTTERFLY VALVE WITH TW-7 PNEUMATIC CYLINDER ACTUATOR OR APPROVED EQUAL	EA	4	\$ 13,000.00	\$ 52,000.00
8	INSTALL 20" DEZURIK C504 BAW BUTTERFLY VALVE WITH TW-7 PNEUMATIC CYLINDER ACTUATOR OR APPROVED EQUAL	EA	3	\$ 8,500.00	\$ 25,500.00
9	REMOVE 12" BUTTERFLY VALVE AND REPLACE WITH 12" CAP	EA	11	\$ 2,200.00	\$ 24,200.00
10	REMOVE 20' OF 1/2" COPPER AIR LINE AND REPLACE WITH SHUT OFF VALVE	EA	12	\$ 400.00	\$ 4,800.00
11	PERMIT COSTS ALLOWANCE, CONTINGENCY ITEM	LS	1	\$ 2,500.00	\$ 2,500.00
12	UNFORESEEN SITE CONDITIONS ALLOWANCE, CONTINGENCY ITEM	LS	1	\$ 100,000.00	\$ 100,000.00
GRAND TOTAL:					\$ 376,000.00

ITEM	DESCRIPTION	UNITS	QTY	UNIT PRICE	AMOUNT
1	BONDS AND INSURANCE EXPENSES	LS	1	\$ 8,200.00	\$ 8,200.00
2	MOBILIZATION, DEMOBILIZATION and RESTORATION COMPLETE (Not to exceed 5% of total bid amount)	LS	1	\$ 11,600.00	\$ 11,600.00
3	FURNISH AND INSTALL 36" DEZURIK AWWA C504 BUTTERFLY VALVE OR APPROVED EQUAL	EA	2	\$ 40,750.00	\$ 81,500.00
4	FURNISH AND INSTALL 30" VAL-MATIC AWWA C504 150B BUTTERFLY VALVE OR APPROVED EQUAL	EA	1	\$ 41,100.00	\$ 41,100.00
5	FURNISH 10" VAL-MATIC SWING FLEX CHECK VALVE 510A OR APPROVED EQUAL	EA	4	\$ 2,700.00	\$ 10,800.00
6	INSTALL 10" VAL-MATIC SWING FLEX CHECK VALVE 510A OR APPROVED EQUAL	EA	2	\$ 6,200.00	\$ 12,400.00
7	FURNISH 20" DEZURIK C504 BAW BUTTERFLY VALVE WITH TW-7 PNEUMATIC CYLINDER ACTUATOR OR APPROVED EQUAL	EA	4	\$ 17,200.00	\$ 68,800.00
8	INSTALL 20" DEZURIK C504 BAW BUTTERFLY VALVE WITH TW-7 PNEUMATIC CYLINDER ACTUATOR OR APPROVED EQUAL	EA	3	\$ 13,000.00	\$ 39,000.00
9	REMOVE 12" BUTTERFLY VALVE AND REPLACE WITH 12" CAP	EA	11	\$ 4,600.00	\$ 50,600.00
10	REMOVE 20' OF 1/2" COPPER AIR LINE AND REPLACE WITH SHUT OFF VALVE	EA	12	\$ 500.00	\$ 6,000.00
11	PERMIT COSTS ALLOWANCE, CONTINGENCY ITEM	LS	1	\$ 2,500.00	\$ 2,500.00
12	UNFORESEEN SITE CONDITIONS ALLOWANCE, CONTINGENCY ITEM	LS	1	\$ 100,000.00	\$ 100,000.00
GRAND TOTAL:					\$ 432,500.00

ITEM	DESCRIPTION	UNITS	QTY	UNIT PRICE	AMOUNT
1	BONDS AND INSURANCE EXPENSES	LS	1	\$ 10,000.00	\$ 10,000.00
2	MOBILIZATION, DEMOBILIZATION and RESTORATION COMPLETE (Not to exceed 5% of total bid amount)	LS	1	\$ 8,890.00	\$ 8,890.00
3	FURNISH AND INSTALL 36" DEZURIK AWWA C504 BUTTERFLY VALVE OR APPROVED EQUAL	EA	2	\$ 84,130.00	\$ 168,260.00
4	FURNISH AND INSTALL 30" VAL-MATIC AWWA C504 150B BUTTERFLY VALVE OR APPROVED EQUAL	EA	1	\$ 211,330.00	\$ 211,330.00
5	FURNISH 10" VAL-MATIC SWING FLEX CHECK VALVE 510A OR APPROVED EQUAL	EA	4	\$ 3,400.00	\$ 13,600.00
6	INSTALL 10" VAL-MATIC SWING FLEX CHECK VALVE 510A OR APPROVED EQUAL	EA	2	\$ 11,400.00	\$ 22,800.00
7	FURNISH 20" DEZURIK C504 BAW BUTTERFLY VALVE WITH TW-7 PNEUMATIC CYLINDER ACTUATOR OR APPROVED EQUAL	EA	4	\$ 19,400.00	\$ 77,600.00
8	INSTALL 20" DEZURIK C504 BAW BUTTERFLY VALVE WITH TW-7 PNEUMATIC CYLINDER ACTUATOR OR APPROVED EQUAL	EA	3	\$ 16,080.00	\$ 48,240.00
9	REMOVE 12" BUTTERFLY VALVE AND REPLACE WITH 12" CAP	EA	11	\$ 11,950.00	\$ 131,450.00
10	REMOVE 20' OF 1/2" COPPER AIR LINE AND REPLACE WITH SHUT OFF VALVE	EA	12	\$ 2,880.00	\$ 34,560.00
11	PERMIT COSTS ALLOWANCE, CONTINGENCY ITEM	LS	1	\$ 2,500.00	\$ 2,500.00
12	UNFORESEEN SITE CONDITIONS ALLOWANCE, CONTINGENCY ITEM	LS	1	\$ 100,000.00	\$ 100,000.00
GRAND TOTAL:					\$ 829,230.00

Weiss Construction bid the following exceptions: Quotes received on bid day for specified ValMatic 30' Butterfly Valves indicate that they are 48-50 wk lead time, yet the project duration is only 200 days, before LDs. Deduct \$50,000 to waive LDs.



PUBLIC SERVICE DEPARTMENT
WASTE WATER TREATMENT PLANT
32360 Warkop
Warren, Michigan 48093
(586) 264-2530
www.cityofwarren.org

May 13, 2024

Ms. Mindy Moore
City Council Secretary

RE: CONSIDERATION AND ADOPTION OF RESOLUTION to Award Bid and Approve Contract for City Project WWTP-24-001, WWTP Sand Filter Valve Replacements (ITB-W-1194) to the low bidder, CSM Mechanical Inc. in the total bid amount not to exceed \$334,315.00 and authorizing Mayor and Clerk to execute a Contract.

Electronic bids were received and publicly read via Zoom Video Conferencing on May 8, 2024 for the City project WWTP-24-001, WWTP Sand Filter Valve Replacement (ITB-W-1194). The project was advertised on the BidNet Direct (MITN) procurement system on April 17, 2024.

The scope of the project includes the replacement of several valves in the WWTP Sand Filter Building that are critical to plant operations.

The low bidder is CSM Mechanical Inc. with a grand total bid amount of \$334,315.00.

CSM Mechanical Inc. has satisfactorily completed similar work bid at the Wastewater Treatment Plant and at other facilities in the Metro area and appears to be qualified to perform the project work.

Based on the review of the bids, it is recommended that the City award Contract WWTP-24-001, WWTP Sand Filter Valve Replacements (ITB-W-1194) be made to the low bidder CSM Mechanical Inc., in the total bid amount not to exceed \$334,315.00

The availability of the funding for this work, as stated in the attached City Council resolution, has been confirmed and approved by the Budget Director.

Please place this item on the May 28, 2024 City Council agenda for approval consideration.

Funding for this work is available in the 2024 FY Capital Outlays Account No. 592-9047-98080.

Should you have any questions regarding this matter, I can be reached in my office at (586) 264-2530 ext. 8103.

Sincerely,

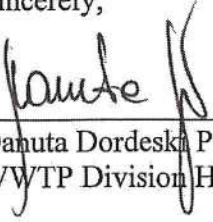

Danuta Dordeska P.E.
WWTP Division Head

Read and Concurred:



Dave Muzzarelli
Public Service Director

Read and Concurred:



Craig Treppa
Purchasing Agent

Funding Approval:

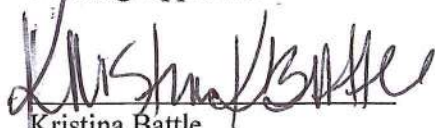

Kristina Battle
Budget Director

Contract Form Approval:



Mary Michaels
Acting City Attorney

Recommended to Council:

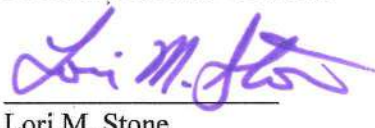

Lori M. Stone
Mayor

DD/jrj

Attachments: Bid tabulation
City Council Resolution

RESOLUTION

Document No: ITB-W-1194

Product or Service: Sand Filter Valve Replacements

Requesting Department: Waste Water Treatment Plant

At a Regular Meeting of the City Council of the City of Warren, County of Macomb, Michigan, held on _____, 2024 at 7 p.m. Local Time, in the Council Chamber at the Warren Community Center Auditorium, 5460 Arden, Warren, Michigan.

PRESENT: Councilmembers: _____

ABSENT: Councilmembers: _____

The following preamble and resolution were offered by Councilmember _____ and supported by Councilmember _____.

Electronic bids were accepted on the BidNet (MITN) system, publicly opened and read on May 8, 2024.

The following bids have been received by City Council:

BIDDER:

AMOUNT:

Please see attached bid tabulation

The bid of CSM Mechanical, Inc., 1235 Holden Ave., Milford, MI 48381, has been determined to be the low responsible and cost-effective bidder to replace sand filter valves in the Waste Water Treatment Plant Sand Filter Building in an amount of \$334,315.00.

Funds are available in the following Account: 592-9047-98080.

IT IS RESOLVED, that the bid of CSM Mechanical, Inc. is hereby accepted by City Council to replace sand filter valves in an amount of \$334,315.00.

IT IS FURTHER RESOLVED, that the Purchasing Agent and/or Mayor and City Clerk are authorized to execute any such documents that are necessary for this approval consistent with the terms of the:

- Bid document
- Contract
- Resolution

and in such form that meets with the satisfaction of the City Attorney if review is required.

AYES: Councilmembers: _____

NAYS: Councilmembers: _____

RESOLUTION DECLARED ADOPTED this ____ day of _____, 2024.

Mindy Moore
Secretary of the Council



CITY CONTROLLER'S OFFICE
ONE CITY SQUARE, SUITE 425
WARREN, MI 48093-5289
(586) 574-4600
FAX (586) 574-4614
www.cityofwarren.org

DATE: MAY 16, 2024
TO: MINDY MOORE, SECRETARY, WARREN CITY COUNCIL
SUBJECT: RECOMMENDATION FOR ROOF REPLACEMENT OF BUILDINGS I AND J OF THE WASTE WATER TREATMENT PLANT (WWTP); ITB-W-1145

The Purchasing Division concurs with the Waste Water Treatment Plant (WWTP) and recommends that Bid ITB-W-1145, for Replacing the Roof on Buildings I and J of the WWTP, be awarded to the low responsible and cost effective bidder, Schena Roofing & Sheet Metal Company (Schena Roofing), 28299 Kehrig Drive, Chesterfield, MI 48047, in the total amount not to exceed \$424,500.00.

On May 1, 2024 at 1:00 PM electronic bids for ITB-W-1145; to Replace the Roof on Buildings I and J of the WWTP was publicly opened. Bids were solicited through BidNet® (MITN). Four (4) vendors responded with a bid, which included a base bid and an alternate bid. Schena Roofing submitted two (2) voluntary alternates, as well. The bid results are summarized on the attached bid tabulation sheet submitted for your review.

The roofs on WWTP buildings I and J are twenty-four (24) years old, out of warranty, and have deteriorated to a point that they need to be replaced in order to protect the expensive and critical sludge dewatering and incineration equipment that these buildings house.

The City asked for pricing that required a minimum R-20 insulation (base bid) and pricing that required an average R-20 insulation (alternate bid). Schena Roofing submitted the lowest bid for both the base bid (\$443,985.00) and the alternate bid (\$424,500.00). In addition, Schena Roofing submitted two voluntary alternate bids.

After evaluating the bids with Hubbell, Roth & Clark (HRC), the City's engineering firm on this project, the WWTP is recommending that the City award the low alternate bid submitted by Schena Roofing in the amount of \$424,500.00. HRC agrees with this recommendation.

Schena Roofing has installed similar roof systems on four (4) separate building at the WWTP and also provides roof maintenance and warranty services for the WWTP to the satisfaction of the City.

Funds for this purchase are available in the following Account: 592-9047-98080.

Respectfully Submitted,

Craig Treppa
Purchasing Agent

Approved By:	Signature	Date
Budget Director:		5/20/2024
Controller:		5/20/2024
MAYOR:		5/20/2024

BID TABULATION ITB-W-1145
 WWTP BUILDING I & J ROOF REPLACEMENT
 BID OPENING: 5/1/2024
 CITY OF WARREN - ONE CITY SQUARE, WARREN, MI 48093
 MACOMB COUNTY, MICHIGAN
 HRC Project Number - 20210638

Bloom Roofing Systems Inc.
 12238 Emerson Dr.
 Brighton, MI 48116

JD Candler Roofing
 6111 Sterling Dr. N,
 Sterling Heights, MI 48312

Newton Crane Roofing, Inc
 353 N. Cass Ave.
 Pontiac, MI 48342

Schena Roofing & Sheet Metal
 Co. Inc
 28299 Kehrig St.
 Chesterfield, MI 48047

Item	Quantity	Unit	Total Cost	Total Cost	Total Cost	Total Cost
BASE BID						
1. Bonds	1	LS	\$ 4,723.00	\$ 3,000.00	\$ 9,000.00	INCL
2. Demolition	1	LS	\$ 185,931.00	\$ 167,000.00	\$ 65,000.00	INCL
3. New Roofing- Complete	1	LS	\$ 370,782.00	\$ 272,000.00	\$ 400,000.00	\$ 423,985.00
4. Silicon Coating at I9 Roof	1	LS	\$ 19,364.00	\$ 10,000.00	\$ 6,000.00	INCL
5. Mandatory Contingency Allowance	1	LS	\$ 20,000.00	\$ 20,000.00	\$ 20,000.00	\$ 20,000.00
TOTAL AMOUNT OF BASE BID	1	LS	\$ 600,260.00 *	\$ 472,000.00	\$ 500,000.00	\$ 443,985.00
* Items 1-5 did not equal listed total						
ALTERNATE BID						
1. Bonds	1	LS	\$	\$ 3,000.00	\$ 9,000.00	INCL
2. Demolition	1	LS	\$	\$ 167,000.00	\$ 65,000.00	INCL
3. New Roofing- Complete	1	LS	\$	\$ 258,000.00	\$ 393,000.00	\$ 404,500.00
4. Silicon Coating at I9 Roof	1	LS	\$	\$ 10,000.00	\$ 6,000.00	INCL
5. Mandatory Contingency Allowance	1	LS	\$	\$ 20,000.00	\$ 20,000.00	\$ 20,000.00
TOTAL AMOUNT OF ALTERNATE BID	1	LS	NO BID	\$ 458,000.00	\$ 493,000.00	\$ 424,500.00
UNIT PRICING ITEMS						
1. Wood Nailer Replacement	1	LF	\$ 11.00	\$ 4.00	\$ 7.00	\$ 3.50
2. Drain replacement	1	EA	\$ 1,500.00	\$ 1,250.00	\$ 2,600.00	\$ 1,600.00
3. Concrete Roof Deck Repair	1	SF	TBD	\$ 28.00	\$ 250.00	T&M
4. Metal Roof Deck Repair	1	SF	\$ 12.00	\$ 13.00	\$ 14.00	\$ 14.50
VOLUNTARY ALTERNATE A			\$ 576,500.00			\$ 433,775.00
VOLUNTARY ALTERNATE B						\$ 386,988.00

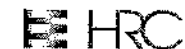



WASTE WATER TREATMENT PLANT
32360 WARKOP
WARREN, MI 48093-6726
(586) 264-2530

MEMO TO: Craig Treppa, Purchasing Agent
Office of the Controller

FROM: Joseph Kovalcik, Wastewater Specialist
Division of Waste Water Treatment

SUBJECT: Award Recommendation for Bid ITB-W-1145
WWTP - Building I & J Roof Replacement

DATE: May 15, 2024

Sealed bids were received and publicly read aloud on May 1, 2024, for bid ITB-W-1145, Building I & J Roof Replacement Project for the City of Warren Wastewater Treatment Division. The roofs on Building I and J are 24 years old, out of warranty, deteriorating and in need of replacement in order to protect the expensive critical sludge dewatering and incineration equipment that is housed inside.

Bids were solicited through the Bid Net (MiTN) System on April 2, 2024. Bids were received from four different roofing companies and publicly read aloud on May 1, 2024. The bids are summarized on the attached bid tabulation.

The specifications for the Base Bid required a minimum R-20 insulation. The specifications for the Alternate Bid allowed for an average R-20 insulation which would provide a cost savings alternate for the project.

After careful evaluation of all of the bids it was determined that Schena Roofing & Sheet Metal Co., Inc. of Chesterfield Township, Michigan, submitted the lowest base bid (\$443,985.00) and submitted the lowest alternate bid (\$424,500.00) as well as submitted two voluntary alternate bids, voluntary alternate bid A (\$433,775.00) and voluntary alternate bid B (\$386,988.00).

Schena Roofing & Sheet Metal Co., Inc. has installed a similar new roof system on Buildings Y (2011), J-Section 1 (2017), C (2018) and N (2019) and has been providing roof maintenance and repair services at the Warren WWTP since 2013 in a satisfactory manner.

After careful evaluation of the Schena Roofing & Sheet Metal Co., Inc. bids a decision was made to seek approval for the lowest alternate bid submitted by Schena Roofing & Sheet Metal Co., Inc., in the amount not to exceed \$424,500.00.

Therefore, in consideration of the above, please take the steps necessary to award bid ITB-W-1145, WWTP Building I & J Roof Replacement, to the lowest qualified bidder, Schena Roofing & Sheet Metal Co., Inc., for the Alternate Bid option, in the amount not to exceed \$424,500.00.

Funds are available in the 24 FY Water and Sewer System Budget, Capital Outlays, Account # 592-9047-98080.

Your usual fine cooperation is appreciated.

Sincerely

Joseph Kovalcik
WWTP Wastewater Specialist

Read and Concurred

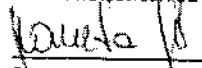
Donna Dordeshi, P.E.
WWTP Division Head

Attachments: Bid Tabulation, Resolution

CC: D. Muzzarelli - Director of Public Service
K. Battle - Budget Director, Controller's Office
J. Kovalcik - WWTP Wastewater Specialist

RESOLUTION

Document No: ITB-W-1145
Product or Service: Building I & J Roof Replacement
Requesting Department: Public Service - WWTP

At a regular meeting of the City Council of the City of Warren, County of Macomb, Michigan, held on _____, 2024, at 7 p.m. Eastern daylight savings Time, in the Council Chamber at the Warren Community Center Auditorium, 5460 Arden, Warren, Michigan.

PRESENT: Councilpersons _____

ABSENT: Councilpersons _____

The following preamble and resolution were offered by Councilperson _____ and supported by Councilperson _____.

On May 1, 2024, bids were received for City Project ITB-W-1145, WWTP Building I & J Roof Replacement, pursuant to the standard sealed bid procedure.

The City Council has received and reviewed the bids as listed on the attached bid tabulation.

The WWTP Division Head has recommended that the contract for City Project ITB-W-1145, WWTP Building I & J Roof Replacement, be awarded to Schena Roofing & Sheet Metal Co., Inc., for the Alternate Bid option, in the total bid amount not to exceed \$424,500.00.

Funding is available in the 2024 FY Water & Sewer System Budget, Capital Outlays, Account #592-9047-98080.

THEREFORE, BE IT RESOLVED, pursuant to the recommendation of the WWTP Division Head, that the City Council by formal motion approves the award of bid ITB-W-1145, WWTP Building I & J Roof Replacement to Schena Roofing & Sheet Metal Co, Inc., 28299 Kehring St., Chesterfield, Michigan 48047, for the Alternate Bid option, in the total bid amount not to exceed \$424,500.00.

BE IT FURTHER RESOLVED, that the Purchasing Agent and/or Mayor and City Clerk are authorized to execute any such documents that are necessary for this approval consistent with the terms of the:

- Bid Document
- Contract
- Resolution

and in such form that meets with the satisfaction of the City Attorney if review is required.

AYES: Councilpersons: _____

NAYS: Councilpersons: _____

RESOLUTION DECLARED ADOPTED this _____ day of _____, 2024.

Mindy Moore
Secretary of the Council



CITY CONTROLLER'S OFFICE
ONE CITY SQUARE, SUITE 425
WARREN, MI 48093-5289
(586) 574-4600
FAX (586) 574-4614
www.cityofwarren.org

DATE: MAY 15, 2024
TO: MINDY MOORE, SECRETARY, WARREN CITY COUNCIL
SUBJECT: TRI-W-1229; AWARD RECOMMENDATION FOR FURNISHING MULTI-FUNCTIONAL DEVICES (MFD) AND MAINTENANCE SERVICES FOR THE CITY OF WARREN

The Purchasing Department recommends that City Council award the purchase of multi-functional devices (MFD), related office equipment, and corresponding Maintenance Services for the City of Warren, to Applied Innovation, 24050 Northwestern Highway, Southfield, MI 48076, through the Farmington Hills Cooperative Contract (FH-22-23-2346), for a period commencing on September 1, 2024 through January 8, 2028, in the not to exceed amounts shown in the chart below.

TERM	MAINTENANCE	MFD DEVICES	TOTAL
9/1/24 thru 1/8/25	\$19,000.00	\$20,000.00	\$39,000.00
1/9/25 thru 1/8/26	\$55,000.00	\$60,000.00	\$115,000.00
1/9/26 thru 1/8/27	\$55,000.00	\$60,000.00	\$115,000.00
1/9/27 thru 1/8/28	\$55,000.00	\$60,000.00	\$115,000.00
GRAND TOTAL:			\$384,000.00

On January 10, 2023, Farmington Hills awarded Applied Innovation with a MFD Management contract that is extendable to the City of Warren. Applied Innovation has been providing the City with MFD and maintenance services for many years and the City has been pleased with Applied Innovation's professionalism, timeliness, and service.

By utilizing an authorized service dealer, the City is guaranteed that toner, developer, and replacement parts are Original Equipment Manufacturer (OEM) parts, which prolong the life of the equipment. In addition, the service technicians are certified to work on the City's Ricoh and Canon machines, which means that they are trained to quickly and accurately identify any problems with the equipment and provide the proper solution to keep the equipment running at optimal service levels.

This maintenance agreement will include all labor, travel, parts, toner, developer and supplies necessary to keep the copiers in original design performance condition. Staples and paper are not included in the maintenance agreement charges.

The City currently owns forty-seven (47) multi-functional devices (MFDs) that are being maintained by Applied Innovation.

Applied Innovation has not increased their maintenance fees since 2018. They will remain at \$.0059 for every black copy/print and \$.059 for every color copy/print. These rates will remain constant through the contract period.



If approved by your honorable body, this award shall commence on September 1, 2024 and run through January 8, 2028.

Funds are available in the various departmental accounts.

Respectfully Submitted,

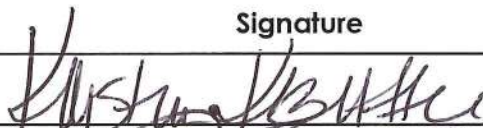

Craig Treppa
Purchasing Agent

Approved By:	Signature	Date
Budget Director:		5/20/2024
Controller:		5/20/2024
MAYOR:		5/21/2024



DEPARTMENT OF CENTRAL SERVICES

ADDENDUM NOTICE NO. 2

OF

CONTRACT NO. FH- 22-23-2346
COPIER & PRINTER MANAGEMENT

NAME & ADDRESS OF VENDOR: Applied Innovation 24050 Northwestern Highway Southfield, MI 48076 Contact-Anna Stewart 248.755.5208 astewart@AppliedInnovation.com Brad Kimball 303-506-7803 bkimball@AppliedInnovation.com	CONTRACT TERM: Current-January 9, 2023 – January 8, 2028 Renewal Option 1- January 9, 2028-January 8, 2030
TERMS: Net 30	BUYER: Michelle Aranowski, Director of Central Services (248) 871-2426 maranowski@fhgov.com
F.O.B.: Delivered	COOPERATIVE: Extension approved to all MITN Purchasing Cooperative Members

NATURE OF CHANGE(S):

Change #1 -Effective immediately, new Cannon models added to agreement.

Change #2 – New purchases or lease will increase 2%.

All other terms, conditions, specifications and pricing provisions remain unchanged.

AUTHORITY/REASON:

Requested by Applied Innovations, Original Approval of agreement 01/09/2023, CMR 1-23-09

FARMINGTON HILLS ESTIMATED CONTRACT VALUE:

\$775,000.00 (FIVE YEAR LEASE)

AUTHORIZATION OF ADDENDUM #1

SIGNED: /s/MICHELLE ARANOWSKI

PRINTED: MICHELLE ARANOWSKI

TITLE: DIRECTOR OF CENTRAL SERVICES

DATE: 02/2/2024

**MASTER AGREEMENT
COPIER & PRINTER MANAGEMENT**

THIS AGREEMENT made and entered into this 10TH day of JANUARY, 2023, by and between the City of Farmington Hills, Oakland County, Michigan, on behalf of themselves, the 47th District Court and the MITN Purchasing Cooperative, Party of the First Part, hereinafter called OWNER, and Party of the Second Part, APPLIED INNOVATION, 24050 NORTHWESTERN HIGHWAY, SOUTHFIELD, MI 48076 hereinafter called the CONTRACTOR.

WITNESSETH, that the Contractor and the Owner, for the consideration hereinafter named agree as follows:

ARTICLE I - THE WORK

It is agreed that the Contractor shall furnish all the insurance, labor & materials to deliver service and products (leased or purchased) shown and called for in the request for proposals titled:

FH-22-23-2346 Copier & Printer Managements

prepared by the City of Farmington Hills, Central Services Department, Oakland County, Michigan, acting as, and in these Contract Documents entitled, the Contract Manager, and shall do everything required by the Contract Documents.

ARTICLE II - THE TIME

It is agreed that the Contractor shall begin work under this Contract upon receipt of written notice to proceed and that the contractor will fulfill all contract requirements for a period of five (5) years from date of contract award. It is further agreed that The City of Farmington Hills acting on behalf of themselves & the MITN Purchasing Cooperative may opt to extend the pricing, terms and conditions of this contract for two (2) additional years upon mutual consent.

ARTICLE III - OWNER'S RIGHT TO CANCEL

It is agreed that if at any time the Contractor should abandon this work; or if he should be adjudged a bankrupt, or if his performance of this Contract is being unnecessarily or unreasonably delayed; or if he should make a general assignment for the benefit of his creditors; or if a receiver should be appointed on account of his insolvency; or if he should persistently or repeatedly fail to fulfill portions of the contract requirements the Owner shall have the right to cancel the Contract with thirty (30) days written notice. Failure to perform specified duties listed herein after two (2) written notices shall constitute grounds for cancellation

ARTICLE IV - ASSIGNMENT OF CONTRACT

It is agreed that the Contractor shall not assign or transfer this Contract or sublet any part of the work embraced in it, except with the written consent of the Owner to do so.

ARTICLE V - THE CONTRACT SUM

And it is agreed that, in consideration of the faithful and entire performance by the Contractor of his obligations under this contract, the Owner, shall pay to him, at the time and in the manner hereinafter stipulated, an amount as determined by the measured quantities and the respective unit prices herein named within thirty (30) days of receipt of the Contractor's invoices. Requested to do so, supported if requested, by sworn statements, satisfactory evidence that all persons who have supplied labor.

The person representing the Contractor who will submit written invoices for payment is designated as

Electronic. The person representing the Owner to whom invoices are to be submitted and questions regarding payment for the *City of Farmington Hills* is Donna Dean, Accounts Payable Clerk.

CITY OF FARMINGTON HILLS
DEPARTMENT OF CENTRAL SERVICES
PURCHASING DIVISION
31555 W. ELEVEN MILB ROAD
FARMINGTON HILLS, MI 48336-1165
www.fhgov.com



PHONE 248-871-2435
FAX 248-871-2431

It is agreed that no issues regarding payment of invoices shall affect the delivery of goods and services & no orders shall be held by the Contractor by the Owner shall be deemed or construed as an acceptance of any part of the work under this contract.

IN WITNESS WHEREOF, the parties have caused these presents to be signed personally or by their duly authorized officers or agents and their seals affixed and duly attested the day and year first written above for Copier & Printer Management.

City of Farmington Hills - Municipality

WITNESSES

[Signature] 1/18/23 BY: Gary Mekjian, City Manager/Date

[Signature] 1/18/23 BY: Pam Smith, City Clerk/Date

CONTRACTOR

WITNESSES

[Signature] BY JOHN KONYVENBELT 1/16/23
Contractor/Date

[Signature] BY: Kirk Morgan 1/16/23
Corporate Counsel

Contractor's signature (s) must be notarized:

STATE OF Michigan

COUNTY OF Kent

Subscribed and sworn to before me this 16th day of January 2023



[Signature]
Notary Public

County Kent

My Commission Expires: March 16th, 2028

APPLIED INNOVATION - 2024 COPIER USAGE

MAINTENANCE CHARGES BASED ON COPIER USAGE MARCH 2023 - APRIL 2024					
#	DEPARTMENT	MODEL NUMBER	ID #	BLACK PRINTS	COLOR PRINTS
				AVERAGE ANNUAL COST FOR COPIES/PRINTS	AVERAGE ANNUAL COST FOR COPIES/PRINTS
1	Assessing	Ricoh MPC6004	57688	\$566.40	\$2,652.00
2	Attorney - Courthouse	Ricoh 3054	54942	\$397.32	
3	Attorney - City Hall	Ricoh MPC6004EX	89078	\$733.44	\$951.24
4	Building	Ricoh MP5001	92531	\$2,124.00	\$1,997.40
5	CDBG	Ricoh MP5001	41041	\$709.56	
6	Clerk	MP5055SP	85816	\$705.84	
7	Communications	Ricoh MPC3504	57970	\$203.16	\$128.88
8	Controller	MP5055SP	100466	\$984.00	
9	Council	Ricoh MP C5503	44412	\$1,699.20	\$0.00
10	Court - Civil	Ricoh MP 3554SP	57908	\$261.48	
11	Court - Main Office	Ricoh MP6055SP	89120	\$662.04	
12	Court - Main Probation	Ricoh IM3500	110057	\$377.04	
13	Court - Center Line	Ricoh IM3500	166203	\$339.84	
14	DPW	Ricoh MP2852SP	34549	\$141.60	
15	DPW	Ricoh IM4000	152961	\$212.40	
16	Drug Court	Ricoh MP3555spad	55798	\$221.88	
17	Engineering	Ricoh IMC4510	150662	\$601.80	\$239.76
18	Fire	Ricoh MP5001	40605	\$708.00	
19	Fire	Ricoh MP5055SP	100887	\$283.20	
20	Library Civic Center - Patron	Ricoh MPC3004	74165	\$433.80	\$96.12
21	Library Civic Center - Patron	Ricoh MPC3004EX	89264	\$232.08	\$0.00
22	Library Civic Center	Canon DXC5840i	152669	\$601.80	\$296.04
23	Library Busch Branch	Ricoh MPC3004	74166	\$394.44	\$344.52
24	Library Burnette Branch	Ricoh MPC3004	74167	\$409.44	\$351.60
25	Library Miller Branch - Staff	Ricoh MPC3004EX	84230	\$673.32	\$124.08
26	Library Miller Branch - Patrons	Ricoh MPC3004	74168	\$212.40	\$0.00
27	Mayor	Ricoh MPC6502SP	44721	\$778.80	\$3,759.24
28	Parks & Rec CC	Ricoh MP5002SP	44623	\$778.56	
29	Personnel	Ricoh MP5055SP	100868	\$714.96	
30	Planning/Prop Maintenance	Ricoh MP C5503	39821	\$1,005.96	\$4,748.40
31	Police - Administration	Ricoh MP5054SP	49826	\$438.36	
32	Police - Administration	Ricoh MP5055SP	92821	\$424.80	
33	Police - Jail	Ricoh IM5000	151019	\$669.60	
34	Police - Traffic	Ricoh IM5000	109658	\$566.40	
35	Police - Traffic	Ricoh MP5054SP	55310	\$1,200.12	
36	Police - SID	Ricoh MP5054	55182	\$566.40	
37	Police - Records	Ricoh MP5054	55445	\$912.24	
38	Public Service	Ricoh IMC4500	152368	\$594.00	\$143.16
39	Rental	Canon/IR6055	133088	\$899.16	\$805.08
40	Sanitation	Ricoh MPC3004EX	74956	\$389.04	\$987.24
41	Senior Housing	Canon IR6055	39127	\$236.04	
42	Senior Housing	Ricoh MPC3004EX	85825	\$566.40	\$1,919.64
43	Treasurer	Ricoh IM5000	129560	\$360.00	
44	Water Garage - 1st Floor	Ricoh MP2852SP	166731	\$120.00	
45	Water Garage - 2nd Floor	Ricoh IM3500	109822	\$212.40	
46	Water Accounting	Ricoh MP5000	109942	\$566.40	
47	WWTP	Ricoh MP5002SP	34972	\$149.64	
ESTIMATED ANNUAL MAINTENANCE CHARGES:		BLACK (\$0.0059 cost per click):		\$27,038.76	
		COLOR (\$0.059 cost per click):			\$19,544.40
ESTIMATED ANNUAL COST:				\$46,583.16	

New Multi-Functional Devices (MFD) were approved in Fiscal Year 2025 budget for the Mayor's Office and Parks & Recreation Dept.

RESOLUTION

Document No: TRI-W-1229

Product or Service: Purchase of Multi-Functional Devices, Related Office Equipment, and Corresponding Maintenance Services

Requesting Department: Various

At a Regular Meeting of the City Council of the City of Warren, County of Macomb, Michigan, held on _____, 2024 at 7 p.m. Local Time, in the Council Chamber at the Warren Community Center Auditorium, 5460 Arden, Warren, Michigan.

PRESENT: Councilmembers: _____

ABSENT: Councilmembers: _____

The following preamble and resolution were offered by Councilmember _____ and supported by Councilmember _____.

Pursuant to Section 2-344 of the Code of Ordinances, the City may either participate in, sponsor, conduct, or administer a cooperative purchasing agreement for the procurement of any supplies, equipment, goods or services with one (1) or more public procurement units.

Upon performing a diligent inquiry, the Purchasing Agent has determined that it is necessary in the interests of the City, to purchase multi-functional devices and corresponding maintenance services for the City utilizing a cooperative contract (FH-22-23-2346) initiated by the City of Farmington Hills, MI, from Applied Innovation, 24050 Northwestern Highway, Southfield, MI 48076.

On January 10, 2023, the City of Farmington Hills, MI awarded Applied Innovation with a cooperative MFD Management contract (FH-22-23-2346) that was extendable to the City of Warren.

The purchasing agent has conducted a review and concurs with the cooperative purchase.

IT IS RESOLVED, that the cooperative contract with Applied Innovation, 24050 Northwestern Highway, Southfield, MI 48076, through the City of Farmington Hills, MI, is hereby accepted by City Council.

IT IS FURTHER RESOLVED, that the agreement shall commence on September 1, 2024 and conclude on January 8, 2028, in the not to exceed amounts shown in the chart below, for the purchase or multi-functional devices and corresponding maintenance services.

TERM	MAINTENANCE	MFD DEVICES	TOTAL
9/1/24 thru 1/8/25	\$19,000.00	\$20,000.00	\$39,000.00
1/9/25 thru 1/8/26	\$55,000.00	\$60,000.00	\$115,000.00
1/9/26 thru 1/8/27	\$55,000.00	\$60,000.00	\$115,000.00
1/9/27 thru 1/8/28	\$55,000.00	\$60,000.00	\$115,000.00
GRAND TOTAL:			\$384,000.00

IT IS FURTHER RESOLVED, that the remit to address for Applied Innovation shall be 7718 Solution Center, Chicago, IL 60677-7007.

IT IS FURTHER RESOLVED, that funds are available in the various Departmental Accounts.

IT IS FURTHER RESOLVED, that the Purchasing Agent and/or Mayor and City Clerk are authorized to execute any such documents that are necessary for this approval consistent with the terms of the:

- Cooperative Bid Document
- Contract
- Resolution

and in such form that meets with the satisfaction of the City Attorney if review is required.

AYES: Councilmembers: _____

NAYS: Councilmembers: _____

RESOLUTION DECLARED ADOPTED this _____ day of _____, 2024.

Mindy Moore
Secretary of the Council

CERTIFICATION

STATE OF MICHIGAN)
) SS.
COUNTY OF MACOMB)

I, Sonja Buffa, duly elected City Clerk for the City of Warren, Macomb County, Michigan, hereby certifies that the foregoing is a true and correct copy of the resolution adopted by the Council of the City of Warren at its meeting held on _____, 2024.

Sonja Buffa
City Clerk



PLANNING DEPARTMENT

ONE CITY SQUARE, SUITE 315
WARREN, MI 48093-5283
(586) 574-4687
FAX (586) 574-4645
www.cityofwarren.org

May 9, 2024

TO: Lori M. Stone, Mayor

FROM: Ronald F. Wuerth, Planning Director

RE: REQUEST TO VACATE PUBLIC ALLEY AND UTILITY EASEMENTS; vacate alley and utility easements and the North/South 18 ft. wide public alley associated with Fire Station #1; located on the Northwest corner of Van Dyke Avenue and Continental Avenue; 23209-23211 Van Dyke Avenue; Section 28, Wilburt McAdams c/o City of Warren. PEV240001

At a public hearing on April 22, 2024, the Planning Commission adopted a resolution pertaining to the above-captioned matter. The resolution, as adopted, is a recommendation to the City Council to APPROVE the request to vacate public alley and utility easements.

You will find attached herewith a copy of the resolution, petitioner's letter, staff findings and recommendation, map, minutes, and plat in connection with this matter.

Should you and/or your staff wish to discuss the details of this project or to go over any of the items in this packet, myself and the Planning staff are available for assistance.

Sincerely,

A handwritten signature in blue ink that reads "Ronald F. Wuerth".

Ronald F. Wuerth, AICP
Planning Director

/mzm

Attachments



PLANNING DEPARTMENT

ONE CITY SQUARE, SUITE 315
WARREN, MI 48093-5283
(586) 574-4687
FAX (586) 574-4645
www.cityofwarren.org

May 9, 2024

TO: Mindy Moore, Secretary
Warren City Council

FROM: Mayor, Planning Commission and Planning Director

RE: REQUEST TO VACATE PUBLIC ALLEY AND UTILITY EASEMENTS; vacate alley and utility easements and the North/South 18 ft. wide public alley associated with Fire Station #1; located on the Northwest corner of Van Dyke Avenue and Continental Avenue; 23209-23211 Van Dyke Avenue; Section 28, Wilburt McAdams c/o City of Warren. PEV240001

At a public hearing on April 22, 2024, the Planning Commission adopted a resolution pertaining to the above-captioned matter. The resolution, as adopted, is a recommendation to the City Council to APPROVE the request to vacate public alley and utility easements.

You will find attached herewith a copy of the resolution, petitioner's letter, staff findings and recommendation, map, minutes, and plat in connection with this matter.

Please schedule this matter for formal action by the City Council. If you have any questions or need additional information, please contact the Planning Director, Ronald Wuertth.

Thank you for your cooperation in this matter.

Respectfully submitted,

Read and Concur:

Handwritten signature of Mahmuda Mouri in black ink.

Mahmuda Mouri
Commission Secretary

Handwritten signature of the Mayor in black ink.

Mayor

/mzm

Attachments

RESOLUTION TO VACATE
PUBLIC ALLEY AND UTILITY EASEMENTS
23209-23211 VAN DYKE AVENUE

A regular meeting of the City Council of the City of Warren, Macomb County, Michigan held on _____, 2024, at 7 p.m. Eastern Daylight Savings Time in at the Warren Community Center, Warren, Michigan.

PRESENT: _____

ABSENT: _____

The following preamble and resolution was offered by Councilmember _____ and supported by Councilmember _____:

On April 22, 2024, the Planning Commission adopted the attached resolution, recommending to the Council of the City of Warren approval of the following four (4) vacations (1 public alley and 3 utility easement vacations) associated with the new Fire Station #1 building to be located on the northwest corner of Van Dyke Ave. and Continental Ave.:

- a) The 18 ft. wide north/south public alley and to remove any easement rights within the vacated public alley abutting Lots 14 through Lot 19 of Roth's Subdivision.
- b) The 5 ft. wide public utility easement located along the south 5 ft. of the east 32 feet of Lot 10 through Lot 14 of Roth's Subdivision.
- c) The 5 ft. wide public utility easement located along the north 5 ft. of Lots 372 through 376 of Piper's Van Dyke Subdivision No.2.
- d) The 8 ft. wide public utility easement located along the west 8 ft. of Lots 377 through 379 of Piper's Van Dyke Subdivision No.2.

Subject to the petitioner complying with the conditions imposed as follows:

1. The Land Division Act includes various procedures pertaining to the amendment of plats, and Petitioner is responsible for complying with any further procedures as may be necessary under Michigan Land Division Act (MCL 560.221 et. Seq.) to complete the vacation.
2. Approval is obtained from City Council. The petitioner must complete the conditions within two (2) years or the approval by City Council shall automatically be revoked.
3. The petitioner must provide the Planning Department with documentation indicating that all conditions as assigned are completed. The department then notifies the City Clerk that a certified copy of the resolution shall be recorded with the Macomb County Register of Deeds.
4. A complaint must be filed by the petitioner in Circuit Court to vacate the public utility easement. As part of the proceedings in Circuit Court, a new revised subdivision plat must be prepared reflecting the changes. The revised plat shall be recorded with the Macomb County Register of Deeds. As an alternative, the petitioner may, by non-judicial process, relinquish the public utility easement by written agreement between certain affected parties. A copy of the court order or relinquishment and the recorded documents must be provided to the Planning Department, Assessing Department, Department of Law, Building Division and City Clerk.

BE IT RESOLVED, the Council of the City of Warren hereby approves the public alley and utility easement vacations for the above-mentioned property of 23209-23211 Van Dyke Avenue.

AYES: _____

NAYS: _____

RESOLUTION DECLARED ADOPTED this _____ day of _____, 2024.

MINDY MOORE
Secretary of the Council

CERTIFICATION

STATE OF MICHIGAN)
) SS.
COUNTY OF MACOMB)

I, Sonja Buffa, duly elected City Clerk for the City of Warren, Macomb County, Michigan, hereby certify that the foregoing is a true and correct copy of the resolution adopted by the Council of the City of Warren at its meeting held on _____, 2024.

SONJA BUFFA
City Clerk

When recorded return to:

City Clerk
One City Square, Suite 205
Warren, Michigan 48093-5285

Drafted by:

Melissa Z. Maisano
Planning Department
City of Warren
One City Square, Suite 315
Warren, Michigan 48093-5285

RESOLUTION

The Planning Commission of the City of Warren having published Notice of Public Hearing in accordance with the statutes and ordinances governing the same and having held a public hearing thereon on Monday, the 22nd day of April, 2024, in the Council Chamber at the Warren Community Center Auditorium, 5460 Arden, Warren, Michigan, and having considered the objections raised thereto, resolves to recommend for approval, and does so recommend to the Council of the City of Warren, the following four (4) vacations (1 public alley and 3 utility easement vacations) associated with the new Fire Station #1 building to be located on the northwest corner of Van Dyke Ave. and Continental Ave.:

- a) The 18 ft. wide north/south public alley and to remove any easement rights within the vacated public alley abutting Lots 14 through Lot 19 of Roth's Subdivision.
- b) The 5 ft. wide public utility easement located along the south 5 ft. of the east 32 feet of Lot 10 through Lot 14 of Roth's Subdivision.
- c) The 5 ft. wide public utility easement located along the north 5 ft. of Lots 372 through 376 of Piper's Van Dyke Subdivision No.2.
- d) The 8 ft. wide public utility easement located along the west 8 ft. of Lots 377 through 379 of Piper's Van Dyke Subdivision No.2.

Subject to the petitioner complying with the conditions imposed as follows:

1. The Land Division Act includes various procedures pertaining to the amendment of plats, and Petitioner is responsible for complying with any further procedures as may be necessary under Michigan Land Division Act (MCL 560.221 et. Seq.) to complete the vacation.
2. Approval is obtained from City Council. The petitioner must complete the conditions within two (2) years or the approval by City Council shall automatically be revoked.
3. The petitioner must provide the Planning Department with documentation indicating that all conditions as assigned are completed. The department then notifies the City Clerk that a certified copy of the resolution shall be recorded with the Macomb County Register of Deeds.

4. A complaint must be filed by the petitioner in Circuit Court to vacate the public utility easement. As part of the proceedings in Circuit Court, a new revised subdivision plat must be prepared reflecting the changes. The revised plat shall be recorded with the Macomb County Register of Deeds. As an alternative, the petitioner may, by non-judicial process, relinquish the public utility easement by written agreement between certain affected parties. A copy of the court order or relinquishment and the recorded documents must be provided to the Planning Department, Assessing Department, Department of Law, Building Division and City Clerk.

RESOLUTION adopted at the meeting of April 22, 2024.

PLANNING COMMISSION OF THE CITY OF WARREN



Warren Smith, Chair

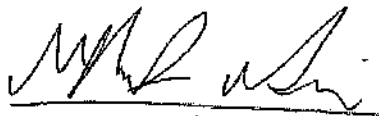

Mahmuda Mouri, Secretary



PLANNING DEPARTMENT

ONE CITY SQUARE, SUITE 315

WARREN, MI 48093-5283

(586) 574-4687

Fax (586) 574-4645

www.cityofwarren.org

April 26, 2024

City of Warren
Wilburt McAdams
23295 Schoenherr Road
Warren, MI 48089

RE: REQUEST TO VACATE PUBLIC ALLEY AND UTILITY EASEMENTS; vacate alley and utility easements and the North/South 18 ft. wide public alley associated with Fire Station #1; located on the Northwest corner of Van Dyke Avenue and Continental Avenue; 23209-23211 Van Dyke Avenue; Section 28, Wilburt McAdams c/o City of Warren. PEV240001

Dear Commissioner McAdams:

At its meeting of April 22, 2024, the City of Warren Planning Commission voted to recommend for **APPROVAL** the following four (4) vacations (1 public alley and 3 utility easement vacations) associated with the new Fire Station #1 building to be located on the northwest corner of Van Dyke Ave. and Continental Ave.:

- a) The 18 ft. wide north/south public alley and to remove any easement rights within the vacated public alley abutting Lots 14 through Lot 19 of Roth's Subdivision.
- b) The 5 ft. wide public utility easement located along the south 5 ft. of the east 32 feet of Lot 10 through Lot 14 of Roth's Subdivision.
- c) The 5 ft. wide public utility easement located along the north 5 ft. of Lots 372 through 376 of Piper's Van Dyke Subdivision No.2.
- d) The 8 ft. wide public utility easement located along the west 8 ft. of Lots 377 through 379 of Piper's Van Dyke Subdivision No.2.

Subject to the petitioner complying with the conditions imposed as follows:

1. The Land Division Act includes various procedures pertaining to the amendment of plats, and Petitioner is responsible for complying with any further procedures as may be necessary under Michigan Land Division Act (MCL 560.221 et. Seq.) to complete the vacation.

2. Approval is obtained from City Council. The petitioner must complete the conditions within two (2) years or the approval by City Council shall automatically be revoked.
3. The petitioner must provide the Planning Department with documentation indicating that all conditions as assigned are completed. The department then notifies the City Clerk that a certified copy of the resolution shall be recorded with the Macomb County Register of Deeds.
4. A complaint must be filed by the petitioner in Circuit Court to vacate the public utility easement. As part of the proceedings in Circuit Court, a new revised subdivision plat must be prepared reflecting the changes. The revised plat shall be recorded with the Macomb County Register of Deeds. As an alternative, the petitioner may, by non-judicial process, relinquish the public utility easement by written agreement between certain affected parties. A copy of the court order or relinquishment and the recorded documents must be provided to the Planning Department, Assessing Department, Department of Law, Building Division and City Clerk.

And furthermore recommendations were received from the following divisions and departments:

TAXES: No delinquent taxes.

ENGINEERING: Preliminary review of this site resulted in no comments from the Engineering Division.

DPW: Based on our foreman's investigation this will not affect DPW operations.

FIRE: The Warren Fire Department approves this site plan. If you have any questions please contact me at 586-756-2800 ext. 3300.

MCPW: No objections.

Should you have any questions, please do not hesitate to contact our office at 586-574-4687.

Sincerely,

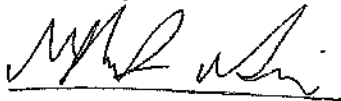

Mahmuda Mouri
Commission Secretary

/mzm

cc: Mayor
Ronald F. Wuerth, Planning Director
Mary Michaels, Chief Assistant City Attorney
Everett Murphy, Chief Zoning Inspector
James Kazanowski, Fire Department

6.) REQUEST TO VACATE PUBLIC ALLEY & UTILITY EASEMENTS

23209 & 23211 VAN DYKE

Process # PEV240001

Section 28

Wilburt McAdams c/o City of Warren

April 22, 2024

Page 1

FINDINGS

1. The petitioner is requesting four (4) vacations (1 alley and 3 easement vacations) associated with the new Fire Station #1 building to be located on the northwest corner of Van Dyke Ave. and Continental Ave. The conditions of vacating the alley and easements were part of the November 21, 2022 Planning Commission recommendation for the site plan for the new building (Fire Station #1).
2. **CHARACTERISTICS OF THE 18 FT. WIDE NORTH/SOUTH PUBLIC ALLEY (ROTH'S SUBDIVISION) IN QUESTION CAN BE SUMMARIZED AS FOLLOWS:**
 - a) The alley has a total width of 18 ft. and a length of 112 ft. The alley is surfaced with grass.
 - b) The public alley is located abutting Lots 14 through Lot 19 of Roth's Subdivision.

The abutting property owner (City of Warren) would have full ownership of the vacated alley.
 - c) The petitioner's purpose for the proposed alley vacation and associated easements within the alley, is to use the property for the new Fire Station #1 building and site.
3. **CHARACTERISTICS OF THE 5 FT. WIDE PUBLIC UTILITY EASEMENT (ROTH'S SUBDIVISION) IN QUESTION CAN BE SUMMARIZED AS FOLLOWS:**
 - a) The easement has a total width of 5 ft. and a length of 182 ft. (the length affected for the site in question; the total length extends west until Peters Ave.) The easement is surfaced with grass. There are utility poles with overhead wires located within the easement area.
 - b) The easement is located along the south 5 ft. of the east 32 feet of Lot 10 through Lot 14 of Roth's Subdivision.
 - c) The petitioner's purpose for the proposed easement vacation request is use the property for the new Fire Station #1 building and site.
4. **CHARACTERISTICS OF THE 5 FT. WIDE PUBLIC UTILITY EASEMENT (PIPER'S VAN DYKE SUBDIVISION NO.2) IN QUESTION CAN BE SUMMARIZED AS FOLLOWS:**
 - a) The easement has a total width of 5 ft. and a length of 200 ft. (the length affected for the site in question; the total length extends west until Peters Ave.)

6.) REQUEST TO VACATE PUBLIC ALLEY & UTILITY EASEMENTS

23209 & 23211 VAN DYKE

Process # PEV240001

Section 28

Wilburt McAdams c/o City of Warren

April 22, 2024

Page 2

The easement is surfaced with grass and pavement. There are utility poles with overhead wires located within the easement area.

- b) The public easement is located along the north 5 ft. of Lots 372 through 376 of Piper's Van Dyke Subdivision No.2.
- c) The petitioner's purpose for the proposed easement vacation request is use the property for the new Fire Station #1 building and site.

5. **CHARACTERISTICS OF THE 8 FT. WIDE PUBLIC UTILITY EASEMENT IN QUESTION CAN BE SUMMARIZED AS FOLLOWS:**

- a) The easement has a total width of 8 ft. and a length of 116 ft. The easement is surfaced pavement. There are utility poles with overhead wires located within the easement area.
- b) The public easement is located along the west 8 ft. of Lots 377 through 379 of Piper's Van Dyke Subdivision No.2.
- c) The petitioner's purpose for the proposed easement vacation request is use the property for the new Fire Station #1 building and site.

6. **CURRENT STATUS OF APPLICATION**

- a) The present hearing will be the initial formal review of this application by the Planning Commission.
- b) Chapter 34: Streets, sidewalks and other public places; Article II vacating public ways; Section 34-28, Consent by owners; hearing, notice not required; this petition was duly executed by all owners of record of the property contiguous and adjacent to the therefore, no publication of notice of public hearing is required. The City of Warren owns all the land adjacent to the proposed public alley vacation and easement vacations.

NOTE: Per Acting Chief City Attorney Mary Michaels, the ownership of the ownership for the two locations (new Fire Station site, and new Habitat site) will be finalized soon. The City of Warren and Habitat for Humanity have an agreement which involves Habitat relocating to the former Maybelle Burnette library (22005 Van Dyke Ave), and the City to own the former Habitat site for the new Fire Station building adjacent to Civic Center South and the current Maybelle Burnette library (23345 Van Dyke). Habitat is already operating out of 22005 Van Dyke, and has no further interest in the site that will house the new Fire Station #1.

6.) REQUEST TO VACATE PUBLIC ALLEY & UTILITY EASEMENTS

23209 & 23211 VAN DYKE

Process # PEV240001

Section 28

Wilburt McAdams c/o City of Warren

April 22, 2024

Page 3

- c) The Land Division Act provides that "permanent structures may not be erected within easement limits by the owner of the fee but the owner shall have the right to make any other use of the land not inconsistent with the rights of public utilities or the other uses as noted on the plat". This application will involve vacating all easements within the 18 ft. n/s alley and the three (3) other easements as indicated on the subdivision plats.
- d) On November 8, 2023, the Zoning Board of Appeals GRANTED the petitioner permission to:
- 1) Construct a building no less than 11' from the south (side) property line along Continental.
 - 2) Construct a controlled access gate no less than 11' 8" ft. along the south (side) property line along Continental.
 - 3) Construct a 6' high decorative fence no less than 11' 8" ft. along the south (side) property along Continental.
 - 4) Construct a fence that extends 10 ft. past the front building line.
 - 5) Waive required masonry wall along the west property line.
 - 6) Erect 2 wall signs on the east elevation as follows:
 - a. Fire "logo" 173.9 square ft.
 - b. "Warren Fire Department" 80 square ft.
- e) On November 21, 2022, the Planning Commission APPROVED the site plan for new building for Fire Station #1.
- f) On December 7, 2016, the Building Division issued Fence Permit No. PF16-00409 for 115 lineal feet of 4 ft. high wire chain link fence (Parcel 13-28-483-008/7592 Republic).
- g) On December 7, 2016, the Building Division issued Demolition Permit No. PD16-059 to demolish the block wall (Parcel 13-28-483-008/7592 Republic).
- h) On June 25, 1986, the Building Division issued Building Permit No. 108509 for a new parking lot measuring 20 ft. x 40 ft. and containing 800 sq. ft. (Lots 377-379).
- i) On November 1, 1956, the Building Division issued Building Permit No. 25257 for a block commercial building measuring 76 ft. x 80 ft. and containing 6,080 sq. ft. (Lots 378-379).

6.) REQUEST TO VACATE PUBLIC ALLEY & UTILITY EASEMENTS

23209 & 23211 VAN DYKE

Process # PEV240001

Section 28

Wilburt McAdams c/o City of Warren

April 22, 2024

Page 4

- j) On October 19, 1946, the Building Division issued Building Permit No. 5293 for a new cement block commercial addition measuring 20 ft. x 20 ft. and containing 400 sq. ft. (Lots 18-19).

4. GENERAL DESCRIPTION OF ABUTTING PROPERTIES IS AS FOLLOWS:

- a) The property to the north (formerly across Republic Ave.) is zoned C-2, R-1-P, and R-1-C, and contains Civic Center South (Library, City Hall Annex, Police Station, and public park).
- b) The properties to the east across Van Dyke Ave. are zoned C-2 and contain a commercial building (First Choice Muffler and Brake shop) and vacant land.
- c) The properties to the south across Continental Ave. are zoned R-1-P and C-2 and contain vacant property.
- d) The properties to the west are zoned R-1-C, and contain single-family dwellings.
5. Notice letters were sent to the local school district, all City of Warren departments and divisions and affected utilities. Letters have been received from City of Warren Engineering and the Warren Fire Department. DPW also provided comments indicating concerns with the vacation.

There were no objections, written and/or stated, to the alley vacation or easement vacations.

6. A review of the area by the Planning Staff of the area in question indicates that there are overhead utility poles in the areas of the easements. The public alley is unimproved, and does not function as a public alley, and its vacation will have no effect to the neighborhood. The utilities will need to be relocated in order to allow for the new City of Warren Fire Station #1 building to be constructed. This is a City project; therefore, any affected utilities will be relocated to the satisfaction of the utility providers.

6.) REQUEST TO VACATE PUBLIC ALLEY & UTILITY EASEMENTS
23209 & 23211 VAN DYKE
Process # PEV240001
Section 28
Wilburt McAdams c/o City of Warren
April 22, 2024
Page 5

RECOMMENDATION

It is recommended that the following four (4) vacations (1 public alley and 3 utility easement vacations) associated with the new Fire Station #1 building to be located on the northwest corner of Van Dyke Ave. and Continental Ave. be VACATED:

- a) The 18 ft. wide north/south public alley and to remove any easement rights within the vacated public alley abutting Lots 14 through Lot 19 of Roth's Subdivision.
- b) The 5 ft. wide public utility easement located along the south 5 ft. of the east 32 feet of Lot 10 through Lot 14 of Roth's Subdivision.
- c) The 5 ft. wide public utility easement located along the north 5 ft. of Lots 372 through 376 of Piper's Van Dyke Subdivision No.2.
- d) The 8 ft. wide public utility easement located along the west 8 ft. of Lots 377 through 379 of Piper's Van Dyke Subdivision No.2.

Subject to the petitioner complying with the conditions imposed as follows:

1. The Land Division Act includes various procedures pertaining to the amendment of plats, and Petitioner is responsible for complying with any further procedures as may be necessary under Michigan Land Division Act (MCL 560.221 et. Seq.) to complete the vacation.
2. Approval is obtained from City Council. The petitioner must complete the conditions within two (2) years or the approval by City Council shall automatically be revoked.
3. The petitioner must provide the Planning Department with documentation indicating that all conditions as assigned are completed. The department then notifies the City Clerk that a certified copy of the resolution shall be recorded with the Macomb County Register of Deeds.
4. A complaint must be filed by the petitioner in Circuit Court to vacate the public utility easement. As part of the proceedings in Circuit Court, a new revised subdivision plat must be prepared reflecting the changes. The revised plat shall be recorded with the Macomb County Register of Deeds. As an alternative, the petitioner may, by non judicial process, relinquish the public utility easement by written agreement between certain affected parties. A copy of the court order or relinquishment and the recorded documents must be provided to the Planning Department, Assessing Department, Department of Law, Building Division and City Clerk.

6.) REQUEST TO VACATE PUBLIC ALLEY & UTILITY EASEMENTS
23209 & 23211 VAN DYKE
Process # PEV240001
Section 28
Wilburt McAdams c/o City of Warren
April 22, 2024
Page 6

And furthermore recommendation were received from the following division and departments to notify the petitioner that these items will be addressed during the Building Division permit process:

TAXES: No delinquent taxes.

ENGINEERING: Preliminary review of this site resulted in no comments from the Engineering Division.

DPW: Based on our foreman's investigation this will not affect DPW operations.

FIRE: The Warren Fire Department approves this site plan. If you have any questions please contact me at 586-756-2800 ext. 3300.

MCPW: No objections.

REQUEST TO VACATE PUBLIC ALLEY AND UTILITY EASEMENTS; vacate alley and utility easements and the North/South 18ft. wide public alley associated with Fire Station #1; located on the Northwest corner of Van Dyke Avenue and Continental Avenue; 23209-23211 Van Dyke Avenue; Section 28, Wilburt McAdams c/o City of Warren. PEV240001

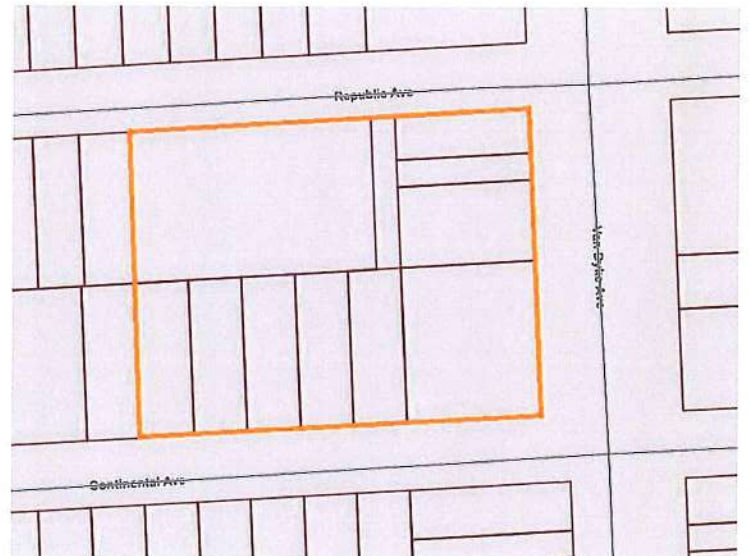

Warren Planning Department
One City Square, Suite 315
Warren, MI 48093
Office: 586-574-4687
CityofWarren.org



His family is here tonight so I want to present this resolution in remembrance of John Kupiec.

Mr. John Kupiec - I'm John's son, John Kupiec. For those of you who knew my father you knew he took this role quite seriously, he took everything in life seriously. He coached quite of few kids in our neighborhood when we were younger. This is my sister Karen, she's the oldest by a longshot and her husband Bob. My wife Kelly, my sister Pat and her son Michael, and my younger sister Carolyn and her husband Ron. My dad had four kids, six grandkids and seven great grandkids to carry on his legacy.

He was a hard-working guy, he came from nothing and built a pretty good life. We grew up in the house that he passed away in at 29709 Orville Drive and loved every minute of it. My sisters and I took swimming lessons right here at Warren High School, we used to walk all the way from Orville Drive to here to take swimming lessons without my mom and dad. Back then you could do that and not worry about it.

I want to thank you all for recognizing my father for his years of service. For those of you who attended his funeral it happened kind of suddenly. We are hoping that he's up in heaven and he's going to bring us a Superbowl this year, as you know the Lions were his passion. Thanks again, and God Bless You.

Chair Smith – God bless you and your family, thank you for coming and representing Commissioner Kupiec tonight.

I'd like to recognize Councilman Magee tonight.

6. PUBLIC HEARING ITEMS:

Members of the audience who wish to address the Planning Commission this evening for a public hearing item may do so by first checking in with the court reporter at the right of the stage and will have three (3) minutes to speak.

REQUEST TO VACATE PUBLIC ALLEY AND UTILITY

EASEMENTS: Vacate alley and utility easements and the North/South 18 ft. wide public alley associated with Fire Station #1; located on the Northwest corner of Van Dyke Avenue and Continental Avenue; 23209-23211 Van Dyke Avenue; Section 28, Wilburt McAdams c/o City of Warren. PEV240001.

PETITIONERS PORTION:

Mr. Wilburt McAdams – This is one of the steps in moving forward in combining these properties that will allow us to build fire station #1 in the south end of the city. I'm looking forward to that process continuing. We are awaiting some utility pole relocations in order to restart construction there. We have demolished the building and the next step for us is to get these utility poles moved as well as what's before you here tonight, the combining of these properties into a single property and look forward to taking that step tonight. I'm here to answer any questions you might have.

Secretary Mouri reads the following correspondence:

TAXES: No Delinquent Taxes.

ENGINEERING: Preliminary review of this site resulted in no comments from the Engineering Division.

DPW: Based on our foreman's investigation this will not affect DPW operations.

FIRE: The Warren Fire Department approves this site plan. If you have any questions, please contact me at 586-756-2800 ext. 3300.

MCPW: No Objections

Mr. Ron Wuerth reads the recommendation of the Staff:

MOTION:

A motion was made by Vice Chair Boniecki to approve, supported by Commissioner Tutt.

COMMISSIONERS PORTION:

Chair Smith – Thank you sir for coming and I'm glad we are going to keep moving forward on this.

ROLL CALL

The motion carried as follows:

Vice Chair Boniecki.....	Yes
Commissioner Tutt.....	Yes
Assistant Secretary Chowdhury.....	Yes
Commissioner Robinson.....	Yes
Commissioner Ansar.....	Yes
Secretary Mouri.....	Yes
Chair Smith.....	Yes

End of Item 4

Calendar Pending Matters

Warren City Council Requests for Information

Meeting Date	Request	Requestor	Responding Department	Due Date/Status
12/12/2023	Request for Clerk to update Municode and reply to Council	Moore	Clerk	12/19/2023
12/19/2023	Civil Service violations of the OMA-copies of the CSC rules and procedures and the back up information including meeting notice and agenda from February 2022	Moore	Human Resources/ Civil Service	1/9/2024

**WARREN CITY COUNCIL
REGULAR MEETING
May 14, 2024**

A Regular Meeting of the Warren City Council was held Tuesday, May 14, 2024, at 7:00 p.m. at the Warren Community Center, 5460 Arden Road, Warren, Michigan 48092.

MEMBERS OF THE COUNCIL PRESENT:

Angela Rogensues, President
Melody Magee, Vice President
Mindy Moore, Council Secretary
Dave Dwyer, Assistant Council Secretary-Mayor Pro Tem
Gary Boike, Council Member
Jonathan Lafferty, Council Member
Henry Newnan, Council Member

ABSENT: None

1. CALL TO ORDER

Council President Rogensues called the meeting to order at 7:00 p.m.

2. PLEDGE OF ALLEGIANCE

3. ROLL CALL

All Members were present.

4. ADOPTION OF THE CONSENT AGENDA

Motion:

Motion to approve was made by Council Member Moore with a support motion by Council Member Lafferty with the request to move items 4j and 4m to the main agenda.

Roll Call:

A roll call vote was taken on the motion. The motion carried (7-0).

Council Member Moore	Yes
Council Member Lafferty	Yes
Council Member Boike	Yes
Council Member Newnan	Yes
Council Member Dwyer	Yes

WARREN CITY COUNCIL
REGULAR MEETING
May 14, 2024
Page 2

Council Member Magee Yes
Council Member Rogensues Yes

5. ADOPTION OF AGENDA

Motion:

Motion to approve the agenda was made by Council Member Moore with a support motion by Council Member Lafferty with the following amendments: Add item 14K, formerly item 4j, add 14L, formerly 4m, add item 13c, appointment of City Assessor F. Scott Miller, add item 12h, Settlement of Rodney Wright v City of Warren as discussed in closed session.

Roll Call:

A roll call vote was taken on the motion. The motion carried (7-0).

Council Member Moore Yes
Council Member Lafferty Yes
Council Member Newnan Yes
Council Member Boike Yes
Council Member Dwyer Yes
Council Member Magee Yes
Council Member Rogensues Yes

6. Calendar Pending Matters

a) **Calendar**

Motion:

Motion to receive and file the calendar was made by Council Member Moore and support was made by Council Member Lafferty.

Voice Vote:

A voice vote was taken on the motion. All "Ayes" recorded. The motion carried (7-0).

7. APPROVAL OF THE MINUTES

a) **Regular Meeting of April 23, 2024**

Motion:

Motion to approve was made by Council Member Moore and support motion made by Council Member Newnan.

Roll Call:

WARREN CITY COUNCIL
REGULAR MEETING
May 14, 2024
Page 3

A roll call vote was taken on the motion. The motion carried (7-0).

Council Member Moore	Yes
Council Member Newnan	Yes
Council Member Dwyer	Yes
Council Member Lafferty	Yes
Council Member Boike	Yes
Council Member Magee	Yes
Council Member Rogensues	Yes

8. APPROVAL OF THE BILLS

a) **General Revenue Funds**

Motion:

Motion to approve the General Fund list of bills was made by Council Member Moore and support motion was made by Council Member Dwyer.

Roll Call:

A roll call vote was taken on the motion. The motion carried (7-0).

Council Member Moore	Yes
Council Member Dwyer	Yes
Council Member Lafferty	Yes
Council Member Newnan	Yes
Council Member Boike	Yes
Council Member Magee	Yes
Council Member Rogensues	Yes

b) **Water and Sewer System**

Motion:

Motion to approve the Water and Sewer System bills made by Council Member Moore and support motion made by Council Member Dwyer.

Roll Call:

A roll call vote was taken on the motion. The motion carried (7-0).

Council Member Moore	Yes
Council Member Dwyer	Yes
Council Member Lafferty	Yes
Council Member Newnan	Yes
Council Member Boike	Yes
Council Member Magee	Yes

WARREN CITY COUNCIL
REGULAR MEETING
May 14, 2024
Page 4

Council Member Rogensues Yes

9. AUDIENCE PARTICPATION: Agenda Items Only

Jeff Mathews
Greg Donahoe

10. ANNOUNCEMENTS

a) Police Week Resolution

Motion:

Motion to approve was made by Council Member Moore and support motion made by Council Member Lafferty.

Voice Vote:

A voice vote was taken on the motion. All “Ayes” recorded. The motion carried (7-0).

Council Member Moore read the resolution in support of the Police Department into the record and announced the Police Ceremony that was to take place on Thursday, May 16th at the FOP hall.

Council Member Lafferty announced Cabaret would be performed by the Warren Civic Theater at Owen Jax on May 17, 18 and 19th, this is an adult performance.

Council Member Magee announced a skilled trades fair that was taking place this Thursday, May 16th.

Council Member Newnan announced the Warren Crime Commissions Senior Health Fair that was taking place at City Hall on Wednesday, May 15, 2024 at 11:00 am.

11. PUBLIC HEARINGS/ADMINISTRATIVE HEARINGS:

a) **ADMINISTRATIVE HEARING:** Request of Fred’s Unique Furniture to appeal a denial of a Secondhand Dealer Business License.

Motion:

Motion to table to a later point in the agenda while information is gathered was made by Council Member Moore and support motion made by Council Member Lafferty.

WARREN CITY COUNCIL
REGULAR MEETING
May 14, 2024
Page 5

Voice Vote:

A voice vote was taken on the motion. All “Ayes” recorded. The motion carried (7-0).

- b) **ADMINISTRATIVE HEARING:** Request of Najma Zafar for a new SDM License to be located at 28853 Bunert, Warren, MI 48088, dba Omega General Store. CONSIDERATION AND ADOPTION OF A RESOLUTION.

Motion:

Motion to approve was made by Council Member Lafferty and support motion was made by Council Member Newnan.

Roll Call:

A roll call vote was taken on the motion. The motion carried (7-0).

Council Member Lafferty	Yes
Council Member Newnan	Yes
Council Member Moore	Yes
Council Member Dwyer	Yes
Council Member Boike	Yes
Council Member Magee	Yes
Council Member Rogensues	Yes

- c) **ADMINISTRATIVE HEARING:** Request of Assaad Ibrahim Sobh for a new Tavern (Beer & Wine) License to be located at 32270 Van Dyke, Warren, Michigan 48093. CONSIDERATION AND ADOPTION OF A RESOLUTION.

Motion:

Motion to approve was made by Council Member Moore and support motion was made by Council Member Lafferty.

Roll Call:

A roll call vote was taken on the motion. The motion carried (7-0).

Council Member Moore	Yes
Council Member Lafferty	Yes
Council Member Dwyer	Yes
Council Member Newnan	Yes
Council Member Boike	Yes
Council Member Magee	Yes
Council Member Rogensues	Yes

WARREN CITY COUNCIL
REGULAR MEETING
May 14, 2024
Page 6

- a) Water Division Operation Report-First Quarter 2024.

Motion:

Motion to receive and file the calendar was made by Council Member Moore and support was made by Council Member Lafferty.

Voice Vote:

A voice vote was taken on the motion. All "Ayes" recorded. The motion carried (7-0).

- b) Request approval of a review panel to review proposals for a Health and Dental Insurance Agent and to approve one member of Council to service on the panel.

Motion:

Motion to approve was made by Council Member Lafferty and support motion was made by Council Member Newnan with the nomination of Council Member Magee to serve on the RFP.

Roll Call:

A roll call vote was taken on the motion. The motion carried (7-0).

Council Member Lafferty	Yes
Council Member Newnan	Yes
Council Member Moore	Yes
Council Member Dwyer	Yes
Council Member Boike	Yes
Council Member Magee	Yes
Council Member Rogensues	Yes

- c) Request approval of a review panel to review proposals for Cyber Security Assessment and to approve one member of Council to service on the panel.

Motion:

Motion to approve was made by Council Member Moore and support motion was made by Council Member Boike with a nomination for Council Member Lafferty to serve on the RFP.

Roll Call:

A roll call vote was taken on the motion. The motion carried (7-0).

Council Member Moore	Yes
Council Member Boike	Yes
Council Member Lafferty	Yes

WARREN CITY COUNCIL
REGULAR MEETING
May 14, 2024
Page 7

Council Member Newnan	Yes
Council Member Dwyer	Yes
Council Member Magee	Yes
Council Member Rogensues	Yes

- d) Request of the Police and Fire Retirement Commission to approve the retirement of Steven Campbell from the Police Department prior to age 50.

Motion:

Motion to approve was made by Council Member Moore and support motion was made by Council Member Newnan.

Roll Call:

A roll call vote was taken on the motion. The motion carried (7-0).

Council Member Moore	Yes
Council Member Newnan	Yes
Council Member Lafferty	Yes
Council Member Dwyer	Yes
Council Member Boike	Yes
Council Member Magee	Yes
Council Member Rogensues	Yes

- e) Request to ratify the proposed City of Warren and UAW 412-59 Extension Agreement.

Motion:

Motion to approve was made by Council Member Moore and support motion was made by Council Member Lafferty.

Roll Call:

A roll call vote was taken on the motion. The motion carried (7-0).

Council Member Moore	Yes
Council Member Lafferty	Yes
Council Member Newnan	Yes
Council Member Dwyer	Yes
Council Member Boike	Yes
Council Member Magee	Yes
Council Member Rogensues	Yes

- f) CONSIDERATION AND ADOPTION OF A RESOLUTION authorizing Quit Claim Deed to City of Warren Tax Increment Finance Authority (TIFA) for real property at 22005 Van Dyke Ave; Parcel No. 13-13-33-278-026.

WARREN CITY COUNCIL
REGULAR MEETING
May 14, 2024
Page 8

Authorizing the Mayor and the City Clerk to execute a contract.
CONSIDERATION AND ADOPTION OF A RESOLUTION.

Motion:

Motion to approve was made by Council Member Moore and support motion was made by Council Member Newnan.

Roll Call:

A roll call vote was taken on the motion. The motion carried (7-0).

Council Member Moore	Yes
Council Member Newnan	Yes
Council Member Lafferty	Yes
Council Member Dwyer	Yes
Council Member Boike	Yes
Council Member Magee	Yes
Council Member Rogensues	Yes

- g) Request of Bloom Capital, LLC, located at 6877 Miller, Warren, MI 48089, for a 60-day extension of their Adult Use Class C License.

Motion:

Motion to approve was made by Council Member Moore and support motion was made by Council Member Lafferty.

Roll Call:

A roll call vote was taken on the motion. The motion carried (7-0).

Council Member Moore	Yes
Council Member Lafferty	Yes
Council Member Newnan	Yes
Council Member Dwyer	Yes
Council Member Boike	Yes
Council Member Magee	Yes
Council Member Rogensues	Yes

- h) (Added) Request to approve settlement of the matter of Rodney Wright v City of Warren, 16th District Court; Case No. 2023-003511-CZ. Hon. James Maceroni, as discussed is closed session.

Motion:

Motion to approve was made by Council Member Moore and support motion was made by Council Member Lafferty.

WARREN CITY COUNCIL
REGULAR MEETING
May 14, 2024
Page 9

Roll Call:

A roll call vote was taken on the motion. The motion carried (7-0).

Council Member Moore	Yes
Council Member Lafferty	Yes
Council Member Newnan	Yes
Council Member Dwyer	Yes
Council Member Boike	Yes
Council Member Magee	Yes
Council Member Rogensues	Yes

13 COUNCIL BUSINESS:

- a) Proposed ordinance amendment to Chapter 37 of the Warren Code of Ordinances relating to Wrecker Licenses. (First Reading)

Motion:

Motion to approve was made by Council Member Moore and support motion was made by Council Member Lafferty.

Roll Call:

A roll call vote was taken on the motion. The motion carried (7-0).

Council Member Moore	Yes
Council Member Lafferty	Yes
Council Member Newnan	Yes
Council Member Dwyer	Yes
Council Member Boike	Yes
Council Member Magee	Yes
Council Member Rogensues	Yes

- b) Council Member Jonathan Lafferty, discussion in re: Reduction of blight in neighborhoods and update from Property Maintenance.

Motion:

Motion to approve was made by Council Member Moore and support motion was made by Council Member Lafferty.

Voice Vote:

A voice vote was taken on the motion. All "Ayes" recorded. The motion carried (7-0).

- c) (Added) Appointment of City Assessor, F. Scott Miller

WARREN CITY COUNCIL
REGULAR MEETING
May 14, 2024
Page 10

Motion:

Motion to approve was made by Council Member Moore and support motion was made by Council Member Lafferty.

Roll Call:

A roll call vote was taken on the motion. The motion carried (7-0).

Council Member Moore	Yes
Council Member Lafferty	Yes
Council Member Newnan	Yes
Council Member Dwyer	Yes
Council Member Boike	Yes
Council Member Magee	Yes
Council Member Rogensues	Yes

14 CORRESPONDENCE FROM THE MAYOR:

- a) CONSIDERATION AND ADOPTION OF A RESOLUTION approving the fiscal year 2024/2025 budget.

Motion:

Motion to approve was made by Council Member Moore and support motion was made by Council Member Lafferty with the following amendments:

**GENERAL APPROPRIATIONS
RESOLUTION ADOPTING FISCAL
YEAR 2024/2025 BUDGET AND
TAX RATE FOR FISCAL YEAR
2024/2025**

A Regular Meeting of the City Council of the City of Warren, County of Macomb, Michigan held May 14, 2024, at 7:00 p.m. Eastern Daylight Savings Time.

PRESENT: Council Members Boike, Dwyer, Lafferty, Magee, Moore, Newnan, Rogensues

ABSENT: Council Members None

WARREN CITY COUNCIL
REGULAR MEETING
May 14, 2024
Page 11

The following resolution was offered by Councilperson Moore and supported by Councilperson Lafferty.

The City of Warren proposed budget for the fiscal year of July 1, 2024 to June 30, 2025 has been submitted by the Mayor to the City Council.

A public hearing on the proposed budget was held on April 23, 2024, and the City Council has completed its review of the Mayor's proposed budget for the fiscal year 2024/2025.

THEREFORE, BE IT RESOLVED, that the Council adopts the sums to be raised by taxation for the general purpose of the City and for the payment of principal and interest on

its indebtedness as follows:

<u>Funds:</u>	<u>Tax Rate</u>
<u>General Fund</u>	
Charter Millage	8.2555
Special Levies:	
Police and Fire Pension	5.4848
Police & Fire Operating	4.6343
Emergency Medical Service	0.2746
Police	0.9210
Fire	<u>0.9210</u>
Total General Fund Operating Levy	20.4912
<u>Special Revenue</u>	
Library (Charter)	0.4582
Library (Voted)	0.7996
Sanitation	2.7514
Parks & Recreation	0.9168
2011 Local Street Repair & Maintenance	<u>1.9858</u>
Total Special Revenue Fund Levy	6.9118

WARREN CITY COUNCIL
REGULAR MEETING
May 14, 2024
Page 12

Total Levy 27.4030

BE IT FURTHER RESOLVED that the aforementioned tax rates shall be adopted as the City tax rate for fiscal year July 1, 2024 to June 30, 2025.

BE IT FURTHER RESOLVED that the 2024/2025 budget shall remain a “line-item” budget.

BE IT FURTHER RESOLVED that the City Council adopts the Mayor’s Proposed Budget for 2024/2025 with the following amendments:

HUMAN RESOURCES

- Reduce Human Resources Director to \$118,615

COMMUNITY AND ECONOMIC DEVELOPMENT

- Reduce Community Outreach Programs to \$0

ADMINISTRATIVE UNALLOCATED EXPENSE

- Reduce National Opioid Settlement Expense to \$0
- Add City Project Management – Contractual - \$50,000

CULTURAL COMMISSION

- Add \$5,000 Contractual Services

CRIME COMMISSION

- Rename Community Outreach to Community Promotion/Outreach Programs

HISTORICAL COMMISSION

- Rename Community Outreach to Community Promotion/Outreach Programs

VILLAGE HISTORICAL COMMISSION

- Rename Community Outreach to Community Promotion/Outreach Programs
- Add \$25,000 contractual services – Skate Park

FIRE DEPARTMENT

- Eliminate M.I.S. Specialist
- Add Chief Technology Officer \$123,854
- Capital Outlays – Proposed Bond Issue – Add Engine - \$1,000,000

POLICE DEPARTMENT

- Add 1 Captain position (4) \$133,577

PLANNING

- Reduce meeting allowance to \$19,275

LIBRARY

- Add Marketing/Promotions – Program Advertisement \$50,000

RECREATION

- Add \$50,000 Marketing/Promotions – Program Advertisement - \$90,000
- Add Capital Outlay-John Deere Gator \$20,000

COMMUNICATIONS

- Delete City Newsletter
- Reduce part-time employees to \$300,000
- Reduce Community Outreach Programs to \$0

DOWNTOWN DEVELOPMENT AUTHORITY OPERATIONS FUND

- Reduce Community Outreach Programs to \$0
- Reduce transfer to TIFA to \$150,000
- Delete \$1,500,000 Capital Outlay – Fire Escape
- Delete \$100,000 Capital Outlay – Historic Preservation
- Add Capital Outlay – WCC Conference Room A Improvements - \$100,000
- Remove Capital Outlay – WCC Improvements - John Deere Gator – Halmich \$20,000

TAX INCREMENT FINANCE AUTHORITY CONSTRUCTION FUND

- Reduce Community Promotions to \$50,000
- Delete \$650,000 Capital Outlays - Louie's Bar
- Other revenue reduced from \$1,000,000 to \$150,000

GENERAL FUND RESERVE

- \$5,000,000 – to be earmarked and reserved for upgrades to substandard homes Economic criteria and accounting recordkeeping to be determined
- \$2,750,000 – to be earmark for Recreational Capital Improvements Funds to

WARREN CITY COUNCIL
REGULAR MEETING
May 14, 2024
Page 15

be transferred as projects are approved

BE IT FURTHER RESOLVED, that if any portion, section, subsection, or other part of this resolution, or its application to any person or circumstance, is invalidated or declared unlawful for any reason, then such portion, section, subsection or other part shall be separable, and the remainder of the resolution shall remain in full force and effect.

AYES: Council Members Moore, Lafferty, Dwyer, Boike, Magee, Newnan, Rogensues.

NAYS: Council Members None RESOLUTION DECLARED ADOPTED THIS

14TH DAY OF MAY, 2024.

Mindy Moore

Mindy Moore, Council Secretary

CERTIFICATION

STATE OF MICHIGAN)
) SS.
COUNTY OF MACOMB)

I, SONJA BUFFA, duly elected City Clerk for the City of Warren, Macomb County, Michigan, hereby certify that the foregoing is a true and correct copy of the resolution adopted by the Council of the City of Warren at its meeting held on

May 14, 2024.

WARREN CITY COUNCIL
REGULAR MEETING
May 14, 2024
Page 16

SONJA BUFFA
City Clerk

Roll Call:

A roll call vote was taken on the motion. The motion carried (7-0).

Council Member Moore	Yes
Council Member Lafferty	Yes
Council Member Newnan	Yes
Council Member Dwyer	Yes
Council Member Boike	Yes
Council Member Magee	Yes
Council Member Rogensues	Yes

- b) Request for an ordinance amending Chapter 41 Article IV of the cod of ordinances of the City of Warren relating to Water and Sewer Rates and Charges. (Second Reading)

Motion:

Motion to approve was made by Council Member Moore and support motion was made by Council Member Newnan.

Roll Call:

A roll call vote was taken on the motion. The motion carried (7-0).

Council Member Moore	Yes
Council Member Newnan	Yes
Council Member Lafferty	Yes
Council Member Dwyer	Yes
Council Member Boike	Yes
Council Member Magee	Yes
Council Member Rogensues	Yes

Council returned to the previously tabled item 11a.

- 11a. Request of Fred's Unique Furniture to appeal a denial of a Secondhand Dealer Business License.

Motion:

Motion to remove from the table was made by Council Member Moore and support motion made by Council Member Lafferty.

WARREN CITY COUNCIL
REGULAR MEETING
May 14, 2024
Page 17

Voice Vote:

A voice vote was taken on the motion. All “Ayes” recorded. The motion carried (7-0).

Motion:

Motion to overturn the denial for one (1) year to allow for compliance and all certifications, otherwise C of O would be revoked was made by Council Member Moore and support motion made by Council Member Lafferty.

Roll Call:

A roll call vote was taken on the motion. The motion carried (7-0).

Council Member Moore	Yes
Council Member Lafferty	Yes
Council Member Newnan	Yes
Council Member Dwyer	Yes
Council Member Boike	Yes
Council Member Magee	Yes
Council Member Rogensues	Yes

- c) Request for the creation of a special revenue fund for the accounting of the Opioid Settlement Funds 1. authorizing the transfer of a total of \$951,124.00 from the general fund to the new Opioid Settlement Fund. 2. Authorizing the expenditure of those fund for Community Outreach and Prevention Programs in the full amount of \$951,124.00. CONSIDERATION AND ADOPTION OF RESOLUTIONS. (5 votes needed)

Motion:

Motion to approve was made by Council Member Moore and support motion was made by Council Member Lafferty with the amendment that no expenditure is approved. Only approving the creation of the special revenue fund and the transfer of the funds from the general fund to the new special revenue account.

Roll Call:

A roll call vote was taken on the motion. The motion carried (7-0).

Council Member Moore	Yes
Council Member Lafferty	Yes
Council Member Newnan	Yes
Council Member Dwyer	Yes
Council Member Boike	Yes
Council Member Magee	Yes

WARREN CITY COUNCIL
REGULAR MEETING
May 14, 2024
Page 18

Council Member Rogensues Yes

- d) Request of the Insurance Department for an increase in budgeted appropriations for a transfer of funds between line items in the amount of \$500,000.00 and additional appropriation of funds from the Administrative Unallocated in the amount of \$110,000.00 to provide sufficient funding in several accounts of the general fund to cover increased insurance costs and contractual obligations. CONSIDERATION AND ADOPTION OF A RESOLUTION. (5 votes needed)

Motion:

Motion to approve was made by Council Member Moore and support motion was made by Council Member Lafferty.

Roll Call:

A roll call vote was taken on the motion. The motion carried (7-0).

Council Member Moore	Yes
Council Member Lafferty	Yes
Council Member Newnan	Yes
Council Member Dwyer	Yes
Council Member Boike	Yes
Council Member Magee	Yes
Council Member Rogensues	Yes

- e) Request of the Fire Commissioner for an additional appropriation of funds in the amount of \$751,245.00 and a transfer of funds between line items in the amount of \$700,000.00 in order to cover increased operating and building maintenance costs, increased costs for the Heavy Rescue Vehicle and SCBA equipment purchase, and contractual obligations. CONSIDERATION AND ADOPTION OF A RESOLUTION. (5 votes needed)

Motion:

Motion to approve was made by Council Member Moore and support motion was made by Council Member Dwyer.

Roll Call:

A roll call vote was taken on the motion. The motion carried (7-0).

Council Member Moore	Yes
Council Member Dwyer	Yes
Council Member Newnan	Yes
Council Member Lafferty	Yes
Council Member Boike	Yes

WARREN CITY COUNCIL
REGULAR MEETING
May 14, 2024
Page 19

Council Member Magee	Yes
Council Member Rogensues	Yes

- f) Request for a transfer of funds between line items in the amount of \$76,600.00 for the Assessing Department, Controller and Police Department in order to provide sufficient funding for the balance of the 2024 fiscal year. CONSIDERATION AND ADOPTION OF A RESOLUTION. (5 votes needed)

Motion:

Motion to approve was made by Council Member Moore and support motion was made by Council Member Dwyer.

Roll Call:

A roll call vote was taken on the motion. The motion carried (7-0).

Council Member Moore	Yes
Council Member Dwyer	Yes
Council Member Newnan	Yes
Council Member Lafferty	Yes
Council Member Boike	Yes
Council Member Magee	Yes
Council Member Rogensues	Yes

- g) Request of the Police Department to extend the award for License Plate Reader Technology to Flock Safety in the total amount of \$121,000.00 for a two (2) year period. CONSIDERATION AND ADOPTION OF A RESOLUTION.

Motion:

Motion to table was made by Council Member Newnan and support motion was made by Council Member Magee.

Roll Call:

A roll call vote was taken on the motion. The motion failed (2-5).

Council Member Newnan	Yes
Council Member Magee	Yes
Council Member Moore	No
Council Member Dwyer	No
Council Member Lafferty	No
Council Member Boike	No
Council Member Rogensues	No

Motion:

WARREN CITY COUNCIL
REGULAR MEETING
May 14, 2024
Page 20

Motion to approve was made by Council Member Moore and support motion was made by Council Member Dwyer.

Roll Call:

A roll call vote was taken on the motion. The motion carried (5-2).

Council Member Moore	Yes
Council Member Dwyer	Yes
Council Member Newnan	No
Council Member Lafferty	Yes
Council Member Boike	Yes
Council Member Magee	No
Council Member Rogensues	Yes

- h) Request of the City Engineer for an additional appropriation of funds in the amount of \$1,913,036.00 to cover the increased costs for City Project P-22-758; 2022 Large Concrete Pavement Repairs and for City Project WP23-790; Toepher Road Pavement Reconstruction (Mullin to MacArthur).
CONSIDERATION AND ADOPTION OF A RESOLUTION. (5 votes needed)

Motion:

Motion to approve was made by Council Member Lafferty and support motion was made by Council Member Moore.

Roll Call:

A roll call vote was taken on the motion. The motion carried (7-0).

Council Member Lafferty	Yes
Council Member Moore	Yes
Council Member Dwyer	Yes
Council Member Newnan	Yes
Council Member Boike	Yes
Council Member Magee	Yes
Council Member Rogensues	Yes

- i) CONSIDERATION AND ADOPTION OF A RESOLUTION to approve contract modification No. 2 to City Project P-22-758, 2022, Large Concrete Pavement Repairs (ITB-W-0577), increasing the current contract amount by \$1,500,000.00 resulting in an amended contract amount of \$4,760,880.00 to Great Lakes Contracting Solutions.

Motion:

Motion to approve was made by Council Member Lafferty and support motion was made by Council Member Moore.

WARREN CITY COUNCIL
REGULAR MEETING
May 14, 2024
Page 21

Roll Call:

A roll call vote was taken on the motion. The motion carried (7-0).

Council Member Lafferty	Yes
Council Member Moore	Yes
Council Member Dwyer	Yes
Council Member Newnan	Yes
Council Member Boike	Yes
Council Member Magee	Yes
Council Member Rogensues	Yes

- j) Request of the Mayor's Office and the Treasurer's Office for an increase in budgeted appropriations in the amount of \$14,570.00 to cover increased costs in supplies and contractual obligations. CONSIDERATION AND ADOPTION OF A RESOLUTION. (5 votes needed)

Motion:

Motion to approve was made by Council Member Lafferty and support motion was made by Council Member Moore.

Roll Call:

A roll call vote was taken on the motion. The motion carried (7-0).

Council Member Lafferty	Yes
Council Member Moore	Yes
Council Member Dwyer	Yes
Council Member Newnan	Yes
Council Member Boike	Yes
Council Member Magee	Yes
Council Member Rogensues	Yes

- k) (Formerly 4j) Request of the Parks and Recreation Department to award bid ITB-W-1142, for furnishing Halmich Park Concession Building Improvements to Quadrate Construction, LLC in the total amount not to exceed \$349,959.87. CONSIDERATION AND ADOPTION OF A RESOLUTION.

Motion:

Motion to approve was made by Council Member Moore and support motion was made by Council Member Lafferty.

Roll Call:

A roll call vote was taken on the motion. The motion carried (7-0).

WARREN CITY COUNCIL
REGULAR MEETING
May 14, 2024
Page 22

Council Member Lafferty	Yes
Council Member Moore	Yes
Council Member Dwyer	Yes
Council Member Newnan	Yes
Council Member Boike	Yes
Council Member Magee	Yes
Council Member Rogensues	Yes

- I) (Tabled 5.14.2024) (Formerly 4m) Request of the City Treasurer and Public Service Director to waive the bidding process and authorize one (1) year of online service and support to BS&A Software, in the annual amount of \$48,921.00. CONSIDERATION AND ADOPTION OF A RESOLUTION.

Motion:

Motion to table to May 28th was made by Council Member Lafferty and support motion was made by Council Member Dwyer.

Roll Call:

A roll call vote was taken on the motion. The motion carried (7-0).

Council Member Lafferty	Yes
Council Member Dwyer	Yes
Council Member Moore	Yes
Council Member Newnan	Yes
Council Member Boike	Yes
Council Member Magee	Yes
Council Member Rogensues	Yes

15 AUDIENCE PARTICPATION – General Topics

Members of the audience who would like to address the City Council this evening may do so under this Audience portion by filling out the general audience form located at the right side of the stage.

Carl Martin Hoence
Michael Holowaty
Garry Watts
Kenya Coviak
Joel Vanderlinden
Gloria Sankuar
Michael Howard

16 COUNCIL RESPONSE TO AUDIENCE (optional)

WARREN CITY COUNCIL
REGULAR MEETING
May 14, 2024
Page 23

None

17 ADJOURNMENT

Motion:

Motion to adjourn was made by Council Member Moore and support motion made by Council Member Lafferty.

Voice Vote:

A voice vote was taken on the motion. All "Ayes" recorded. The motion carried (7-0).

The meeting adjourned at 9:00 p.m.

Mindy Moore
Secretary of the Council

DRAFT

Total for fund 101 GENERAL FUND	1,369,096.50
Total for fund 202 MTF ACT 51 MAJOR OPERATNG	2,093.51
Total for fund 203 MTF ACT 51 LOCAL OPERATNG	15,431.13
Total for fund 204 2011 LOCAL STREET R&M	1,259,602.03
Total for fund 208 RECREATION SPEC REVENUE	55,187.56
Total for fund 226 SANITATION SPECIAL REV	229,680.37
Total for fund 230 RENTAL ORDINANCE REVENUE	429.93
Total for fund 250 COMMUNICATIONS	15,309.12
Total for fund 259 INDIGENT DEFENSE FUND	20,478.74
Total for fund 261 DRUG FORFEITURE FUND	22,499.39
Total for fund 262 POLICE TRAINING FUND	8,553.80
Total for fund 271 LIBRARY SPECIAL REVENUE	14,642.77
Total for fund 273 CDBG ENTITLEMENT FUND	11,159.42
Total for fund 277 H.O.M.E.	603.50
Total for fund 278 HOUSING OPPORTUNITIES	42,243.00
Total for fund 281 LEAD HAZARD CONTROL GRANT	2,450.00
Total for fund 410 37TH D.C. BLDG RENOVATION	3,214.00
Total for fund 494 DDA ADMINISTRATION FUND	259.33
Total for fund 536 SENIOR HOUSING - STILWELL	26,688.74
Total for fund 537 SENIOR HOUSING-JOS. COACH	92,591.08
Total for fund 592 WATER & SEWER SYSTEM FUND	1,033,843.00
Total for fund 596 W&S PAYROLL REVOLVING FUND	12,793.16
Total for fund 701 UNALLOCATED TAX FUND	300.00
Total for fund 750 PAYROLL REVOLVING FUND	104,123.88
Total for fund 801 S/A REVOLVING FUND	14,466.00
Total for fund 802 SIDEWALK & TREE S/A FUND	469.29
TOTAL - ALL FUNDS	4,358,209.25

Check Date	Bank	Check	Vendor	Vendor Name	Amount
Bank POOL COMERICA GENERAL					
05/09/2024	POOL	666777	000265	CONSUMERS ENERGY	165.50
05/09/2024	POOL	666778	000323	DTE ENERGY	1,783.99
05/09/2024	POOL	666779	000731	AT&T	51.28
05/09/2024	POOL	666780	012239	VERIZON WIRELESS	200.48
05/09/2024	POOL	666781	014433	WINDSTREAM COMMUNICATIONS INC	8,702.16
05/09/2024	POOL	666782	015829	WOW! BUSINESS	1,320.99
05/09/2024	POOL	666783	017939	POINT & PAY	3,241.75
05/09/2024	POOL	666784	019094	THOMAS VANDEPOTTE	23.48
05/09/2024	POOL	666785	019451	LOADOMETER CORPORATION	10,590.00
05/09/2024	POOL	666786	080023	DENCAP	3,534.00
05/09/2024	POOL	666787	099998	SPARTAN PAVING LLC	643.00
05/16/2024	POOL	666788	000323	DTE ENERGY	3,711.97
05/16/2024	POOL	666789	000324	DTE ENERGY	288,073.87
05/16/2024	POOL	666790	000731	AT&T	156.18
05/16/2024	POOL	666791	011369	AT&T MOBILITY	12,840.63
05/16/2024	POOL	666792	012239	VERIZON WIRELESS	3,457.29
05/16/2024	POOL	666793	014815	BERGER CHEVROLET INC	51,522.00
05/16/2024	POOL	666794	016875	TODD WENZEL BUICK GMC	50,117.95
05/16/2024	POOL	666795	019040	AVERY BRIONES	252.00
05/16/2024	POOL	666796	080003	WARREN POLICE COMMAND	1,711.13
05/16/2024	POOL	666797	080009	WARREN MUNICIPAL FEDERAL	70,243.00
05/16/2024	POOL	666798	080079	CHPTR 13 STANDING TRUSTEE	1,277.74
05/16/2024	POOL	666799	080079	CHPTR 13 STANDING TRUSTEE	453.98
05/16/2024	POOL	666800	080118	MISDU	9,663.98
05/16/2024	POOL	666801	080172	CHAPTER 13 TRUSTEE	1,093.00
05/16/2024	POOL	666802	080221	LOCAL U227	8,310.00
05/16/2024	POOL	666803	080247	U.S. ASSET MANAGEMENT	541.65
05/16/2024	POOL	666804	099998	RUSSELL HANSEN	16.00
05/21/2024	POOL	666805	000323	DTE ENERGY	19,471.20
05/29/2024	POOL	666806	000034	AJAX TRAILERS LLC	15.96
05/29/2024	POOL	666807	000043	ALLIE BROTHERS INC	1,659.89
05/29/2024	POOL	666808	000158	BRONER INC	1,376.54
05/29/2024	POOL	666809	000171	BURWOOD BUSINESS MACHINES	138.00
05/29/2024	POOL	666810	000184	C & G PUBLISHING INC	218.50
05/29/2024	POOL	666811	000310	DEMCO INC	309.67
05/29/2024	POOL	666812	000313	DES MOINES STAMP MFG CO	101.70
05/29/2024	POOL	666813	000317	DETROIT CHEMICAL & PAPER	2,250.35
05/29/2024	POOL	666814	000329	OCCUPATIONAL HEALTH CENTERS	438.00
05/29/2024	POOL	666815	000347	DOETSCH INDUSTRIAL SERVICES INC	2,710.00
05/29/2024	POOL	666816	000371	EJ USA INC	2,286.84
05/29/2024	POOL	666817	000394	ETNA SUPPLY COMPANY	7,326.60
05/29/2024	POOL	666818	000400	FEDERAL EXPRESS CORP	240.86
05/29/2024	POOL	666819	000405	FIRE EXTINGUISHER SALES & SERVICE	741.55
05/29/2024	POOL	666820	000417	FLORENCE CEMENT CO	338,535.66
05/29/2024	POOL	666821	000466	GRAINGER INC	7,703.28
05/29/2024	POOL	666822	000484	GROESBECK GLAZING	360.00
05/29/2024	POOL	666823	000502	HAMILTON CHEVROLET INC	47,593.44
05/29/2024	POOL	666824	000542	ICLE	148.50
05/29/2024	POOL	666825	000554	JB DLCO-MULTISTATE	703.20
05/29/2024	POOL	666826	000610	KUSH PAINT COMPANY	456.50
05/29/2024	POOL	666827	000630	TEAM EQUIPMENT COMPANY	198.90
05/29/2024	POOL	666828	000634	SUBURBAN LIBRARY	39.00
05/29/2024	POOL	666829	000868	PATRICK PHOTOGRAPHIC STUDIOS	3,367.00
05/29/2024	POOL	666830	000904	QUICK MADE TROPHY SALES	20.00
05/29/2024	POOL	666831	000965	SUPPLYDEN INC	2,682.64
05/29/2024	POOL	666832	001044	GRAYBAR ELECTRIC COMPANY	3,124.01
05/29/2024	POOL	666833	001054	STATE CHEMICAL SOLUTIONS	1,257.04
05/29/2024	POOL	666834	001086	TERMINAL SUPPLY CO	1,697.43
05/29/2024	POOL	666835	001203	CITY OF WARREN	50,127.24
05/29/2024	POOL	666836	001217	CITY OF WARREN	35.85
05/29/2024	POOL	666837	001241	WARREN PIPE & SUPPLY CO	562.33
05/29/2024	POOL	666838	001253	WEINGARTZ SUPPLY	157.17
05/29/2024	POOL	666839	001258	WEST GROUP	9,601.04
05/29/2024	POOL	666840	001265	WHOLESALE TOOL CO	338.25
05/29/2024	POOL	666841	001296	ZEP MANUFACTURING COMPANY	762.51
05/29/2024	POOL	666842	002231	JOHN R SPRING & TIRE CTR	4,106.21
05/29/2024	POOL	666843	002296	UKRAINIAN CULTURAL CENTER	2,007.47
05/29/2024	POOL	666844	002376	AIELLI CONSTRUCTION CO	43,211.66
05/29/2024	POOL	666845	002443	OSCAR W LARSON CO	315.00
05/29/2024	POOL	666846	002546	MACOMB COUNTY REGISTER	270.00
05/29/2024	POOL	666847	002601	EMEDCO	1,346.74
05/29/2024	POOL	666848	002811	RONALD WUERTH	165.00
05/29/2024	POOL	666849	002915	WILLIAM BRANCH	480.00
05/29/2024	POOL	666850	002954	JADE SCIENTIFIC INC	150.75
05/29/2024	POOL	666851	003002	PIRTEK	340.26
05/29/2024	POOL	666852	003071	VICKI NORMAN	135.00
05/29/2024	POOL	666853	003257	MICHIGAN STATE FIREMEN'S	572.47
05/29/2024	POOL	666854	003260	ROCKET ENTERPRISE INC	1,134.00

Check Date	Bank	Check	Vendor	Vendor Name	Amount
05/29/2024	POOL	666855	003396	SERVICE TOWING INC	565.00
05/29/2024	POOL	666856	003558	INTERSTATE SECURITY INC	375.00
05/29/2024	POOL	666857	003773	MICHIGAN ASSOC OF CHIEFS OF POLICE	415.00
05/29/2024	POOL	666858	003851	CANFIELD EQUIP SVC INC	22,713.48
05/29/2024	POOL	666859	003860	KENNETH J WROBEL	510.00
05/29/2024	POOL	666860	003865	JOHN E REID & ASSOCIATES	580.00
05/29/2024	POOL	666861	003957	BRODART COMPANY	980.98
05/29/2024	POOL	666862	004109	MWEA	1,975.00
05/29/2024	POOL	666863	004227	INGERSOLL-RAND INDUSTRIAL US INC	3,054.83
05/29/2024	POOL	666864	004360	TETRA TECH INC	1,401.37
05/29/2024	POOL	666865	004376	AIRGAS USA LLC	925.57
05/29/2024	POOL	666866	004404	SCHENA ROOFING & SHEET	56,700.00
05/29/2024	POOL	666867	004412	METRO WELDING SUPPLY	38.75
05/29/2024	POOL	666868	004437	UNCONVENTIONAL SOLUTIONS	1,965.53
05/29/2024	POOL	666869	004462	MAURER'S TEXTILE RENTAL	271.96
05/29/2024	POOL	666870	004522	MELISSA HOPKINS	427.75
05/29/2024	POOL	666871	004540	GOODYEAR TIRE & RUBBER CO	2,773.32
05/29/2024	POOL	666872	004562	TRACTION HEAVY DUTY PARTS	268.41
05/29/2024	POOL	666873	004565	DVM UTILITIES INC	194,482.26
05/29/2024	POOL	666874	004638	PERLMUTTER PURCHASING PWR	480.00
05/29/2024	POOL	666875	004699	SOUTH MACOMB DISPOSAL AUTHORITY	132,892.46
05/29/2024	POOL	666876	004700	ETITLE AGENCY INC	625.00
05/29/2024	POOL	666877	004736	CAPP/USA	2,589.00
05/29/2024	POOL	666878	004786	FLUKE ELECTRONICS	843.60
05/29/2024	POOL	666879	004818	ALS ENVIRONMENTAL	1,000.00
05/29/2024	POOL	666880	004865	UTILITIES INSTRUMENTATION	4,536.00
05/29/2024	POOL	666881	004906	BAKER'S GAS AND WELDING SUPPLIES	202.17
05/29/2024	POOL	666882	005229	THE LIBRARY STORE INC	1,454.86
05/29/2024	POOL	666883	005686	MICHIGAN DEPT OF TREASURY	2,355.00
05/29/2024	POOL	666884	005880	PSP STORES LLC	218.55
05/29/2024	POOL	666885	006175	DAWN M WALTON	2,449.30
05/29/2024	POOL	666886	006187	HOME DEPOT CREDIT SERVICE	2,454.99
05/29/2024	POOL	666887	007271	TARGET INFORMATION	203.40
05/29/2024	POOL	666888	007481	APOLLO FIRE APPARATUS SALES & SERVI	293.75
05/29/2024	POOL	666889	007878	AJAX MATERIALS CORPORATION	6,868.80
05/29/2024	POOL	666890	008133	DEPENDABLE WHOLESALE INC	14,629.84
05/29/2024	POOL	666891	008398	B & H PHOTO - VIDEO INC	9,136.26
05/29/2024	POOL	666892	008492	PRESSURE VESSEL TESTING	798.00
05/29/2024	POOL	666893	009029	GORDON FOOD SERVICE INC	1,171.99
05/29/2024	POOL	666894	009144	COLONIAL TITLE	255.00
05/29/2024	POOL	666895	009240	AMERI TIME LLC	348.20
05/29/2024	POOL	666896	009314	CONTRACTORS CONNECTION	89.80
05/29/2024	POOL	666897	009336	DAVID WORDEN	690.00
05/29/2024	POOL	666898	009421	AIS CONSTRUCTION EQUIPMENT	863.80
05/29/2024	POOL	666899	009457	ANDREW M CANU	2,040.00
05/29/2024	POOL	666900	009600	MDOT	190.07
05/29/2024	POOL	666901	009766	LYNN BIESZKA	1,600.00
05/29/2024	POOL	666902	009874	HD EDWARDS & CO	503.20
05/29/2024	POOL	666903	010045	GREAT LAKES SECURITY HARDWARE	36.16
05/29/2024	POOL	666904	010177	UNITED PARCEL SERVICE	27.98
05/29/2024	POOL	666905	010336	B & B POOLS & SPA CORP	4,440.00
05/29/2024	POOL	666906	010559	LIFEGUARD STORE THE	296.73
05/29/2024	POOL	666907	010587	COPY COPY CENTER	449.00
05/29/2024	POOL	666908	010591	LORAIN C KENNY	400.00
05/29/2024	POOL	666909	010612	ARC DOCUMENT SOLUTIONS LLC	1,004.27
05/29/2024	POOL	666910	010776	BOUND TREE MEDICAL	4,463.89
05/29/2024	POOL	666911	010843	ULINE INC	5,011.62
05/29/2024	POOL	666912	010861	MATHEW A LICATA	1,560.00
05/29/2024	POOL	666913	010875	GOV CONNECTION INC	5,209.92
05/29/2024	POOL	666914	010996	GEMINI FORMS & SYSTEMS	2,015.50
05/29/2024	POOL	666915	011067	PAUL SCALLY	750.00
05/29/2024	POOL	666916	011162	JESSICA R BROWN	175.00
05/29/2024	POOL	666917	011163	DELL MARKETING LP	1,328.14
05/29/2024	POOL	666918	011219	CINTAS FIRST AID & SAFETY	205.38
05/29/2024	POOL	666919	011219	CINTAS FIRST AID & SAFETY	374.84
05/29/2024	POOL	666920	011239	JULIE A HLYWA	450.00
05/29/2024	POOL	666921	011249	ZUNIGA CEMENT CONSTRUCTION INC	301,043.52
05/29/2024	POOL	666922	011278	RAY ALLEN MANUFACTURING	573.25
05/29/2024	POOL	666923	011370	LISA E BIGGS	1,530.00
05/29/2024	POOL	666924	011543	JASON MALKIEWICZ	1,290.00
05/29/2024	POOL	666925	011673	DETROIT SALT	43,054.29
05/29/2024	POOL	666926	011819	IDENTISYS INCORPORATED	128.77
05/29/2024	POOL	666927	011876	VINCENZO MANZELLA	300.00
05/29/2024	POOL	666928	011882	SMART	125.33
05/29/2024	POOL	666929	011980	OTIS ELEVATOR COMPANY	4,725.00
05/29/2024	POOL	666930	012133	MJ ENVIRONMENTAL INC	3,400.00
05/29/2024	POOL	666931	012207	COMPLETION HOUSE	2,700.00
05/29/2024	POOL	666932	012535	JAMES R WOLFE	652.00
05/29/2024	POOL	666933	012574	RICHARD M KOWALEWSKI	500.00
05/29/2024	POOL	666934	012633	MICHELLE KATOPODES	176.25
05/29/2024	POOL	666935	012712	TRUCK AND TRAILER	1,268.87

Check Date	Bank	Check	Vendor	Vendor Name	Amount
05/29/2024	POOL	666936	012833	JH HART URBAN FORESTRY	630.00
05/29/2024	POOL	666937	012860	SUSAN R COLE	1,590.00
05/29/2024	POOL	666938	012928	ZOHO CORPORATION	562.13
05/29/2024	POOL	666939	012981	STATE OF MICHIGAN	10,071.22
05/29/2024	POOL	666940	013066	SHREDCORP	124.00
05/29/2024	POOL	666941	013199	AVIS CHOULAGH LAW PLLC	150.00
05/29/2024	POOL	666942	013226	EMERGENCY VEHICLES PLUS	2,371.31
05/29/2024	POOL	666943	013237	HELLEBUYCKS POWER EQUIP	924.89
05/29/2024	POOL	666944	013258	COUNTRY COURT APARTMENTS	1,191.00
05/29/2024	POOL	666945	013332	DIGIGRAPHX	280.00
05/29/2024	POOL	666946	013336	LANDSCAPE SERVICE INC	14,369.00
05/29/2024	POOL	666947	013343	EUGENIA PALMER	84.20
05/29/2024	POOL	666948	013413	ALERT ALL CORP	4,432.50
05/29/2024	POOL	666949	013577	RKA PETROLEUM COMPANIES	23,692.73
05/29/2024	POOL	666950	013611	CENTER MASS INC	1,978.00
05/29/2024	POOL	666951	013748	ROYAL HILL APARTMENTS INC	392.00
05/29/2024	POOL	666952	013751	IGNITED LIGHT AND SOUND	900.00
05/29/2024	POOL	666953	013938	CYNERGY WIRELESS PRODUCTS	35.00
05/29/2024	POOL	666954	013978	TOSHIBA BUSINESS SOLUTIONS	1,385.35
05/29/2024	POOL	666955	014130	JAMES R HILLER	505.00
05/29/2024	POOL	666956	014153	DONNA CILLUFFO	153.27
05/29/2024	POOL	666957	014316	LARRY R KIPKE ATTORNEY AT	1,620.00
05/29/2024	POOL	666958	014359	APCO SUPPLY	2,660.00
05/29/2024	POOL	666959	014429	MICHIGAN STATE POLICE	570.00
05/29/2024	POOL	666960	014466	KIRK REHN	48.68
05/29/2024	POOL	666961	014492	APPLE INC	3,284.00
05/29/2024	POOL	666962	014552	ACCUMED BILLING INC	19,172.79
05/29/2024	POOL	666963	014553	NORTHWESTERN UNIVERSITY	9,200.00
05/29/2024	POOL	666964	014594	SUBURBAN LIBRARY CO-OP	2,200.83
05/29/2024	POOL	666965	014607	FLEET PRIDE HEAVY DUTY	219.90
05/29/2024	POOL	666966	014616	COSTAR REALTY INFORMATION	1,156.68
05/29/2024	POOL	666967	014619	D/A CENTRAL INC	77,001.94
05/29/2024	POOL	666968	014625	ROMAN T NESTOROWICZ	75.00
05/29/2024	POOL	666969	014635	COMPONE ADMINISTRATORS	14,182.23
05/29/2024	POOL	666970	014642	BULLOCK ENTERPRISES LLC	1,506.00
05/29/2024	POOL	666971	014656	UNIQUE MANAGEMENT	412.50
05/29/2024	POOL	666972	014773	RICHTER & ASSOCIATES INC	728.00
05/29/2024	POOL	666973	014830	EAGLE STAR EQUIPMENT	946.19
05/29/2024	POOL	666974	014867	MICRO CENTER	772.94
05/29/2024	POOL	666975	014993	CITY ELECTRIC SUPPLY	49.90
05/29/2024	POOL	666976	015025	GRIFFIN PEST SOLUTIONS INC	2,069.00
05/29/2024	POOL	666977	015045	MICHAEL ZUIDEMA	497.98
05/29/2024	POOL	666978	015158	4 IMPRINT INC	409.06
05/29/2024	POOL	666979	015159	LABELSTOP	600.00
05/29/2024	POOL	666980	015187	BOBS SPECIALTY COMPANY	4,224.57
05/29/2024	POOL	666981	015218	PRIORITY DISPATCH CORP	425.00
05/29/2024	POOL	666982	015247	GREAT LAKES GRAPHICS INC	26,369.84
05/29/2024	POOL	666983	015343	IAN WEAVER	2,001.00
05/29/2024	POOL	666984	015391	DANIELLE HARDEN	175.00
05/29/2024	POOL	666985	015475	GENUINE PARTS COMPANY	3,731.05
05/29/2024	POOL	666986	015558	APPLIED INNOVATION	2,790.31
05/29/2024	POOL	666987	015577	NEW FRONTIER 21 LLC	1,089.00
05/29/2024	POOL	666988	015583	WOLVERINE POWER SYSTEMS	217.50
05/29/2024	POOL	666989	015621	ROBERT WEIDNER	30.00
05/29/2024	POOL	666990	015622	TG WARREN INC	695.00
05/29/2024	POOL	666991	015671	JENNA BOMMARITO CROSS	335.00
05/29/2024	POOL	666992	015679	INTEGRITY BUSINESS SOLUTIONS	749.80
05/29/2024	POOL	666993	015721	WOW! INTERNET CABLE PHONE	1,908.12
05/29/2024	POOL	666994	015729	FOUR SEASONS RADIATOR	485.00
05/29/2024	POOL	666995	015778	MTECH COMPANY	1,720.63
05/29/2024	POOL	666996	015814	CHEMSEARCH	488.95
05/29/2024	POOL	666997	015829	WOW! BUSINESS	2,523.58
05/29/2024	POOL	666998	015856	KIMBERLY DIBARTOLOMEO	210.00
05/29/2024	POOL	666999	015874	LINGUISTICA INTERNATIONAL	19.20
05/29/2024	POOL	667000	015937	WORLDWIDE INTERPRETERS	706.02
05/29/2024	POOL	667001	015948	RICHARD BREEN	651.09
05/29/2024	POOL	667002	015982	JAMES TAITE	356.26
05/29/2024	POOL	667003	015996	DR RONALD FENTON	1,250.00
05/29/2024	POOL	667004	016005	CLASS 'A' TRAINING CENTER	10,860.00
05/29/2024	POOL	667005	016069	DAVID BEAN	79.72
05/29/2024	POOL	667006	016116	MICHAEL FONTANA	600.00
05/29/2024	POOL	667007	016150	21ST CENTURY MEDIA NEWSPAPER LLC	1,512.25
05/29/2024	POOL	667008	016159	HUNTINGTON NATIONAL BANK	500.00
05/29/2024	POOL	667009	016199	CCP INDUSTRIES	766.45
05/29/2024	POOL	667010	016289	LIGHTING SUPPLY COMPANY	2,269.39
05/29/2024	POOL	667011	016310	SIGNING PROS LLC	215.00
05/29/2024	POOL	667012	016433	ADVERTISING & GRAPHICS	189.53
05/29/2024	POOL	667013	016500	MSC INDUSTRIAL SUPPLY	461.17
05/29/2024	POOL	667014	016618	CHARLES ANGLIN	75.00
05/29/2024	POOL	667015	016627	DEBORAH WEIHERMULLER	120.00
05/29/2024	POOL	667016	016816	SITE ONE LANDSCAPE SUPPLY	185.49

Check Date	Bank	Check	Vendor	Vendor Name	Amount
05/29/2024	POOL	667017	016856	FIVE STAR LANGUAGES	660.00
05/29/2024	POOL	667018	016894	M & K HOLDING COMPANY	10,401.94
05/29/2024	POOL	667019	016947	WOODWARD CAMERA	249.00
05/29/2024	POOL	667020	016994	GFL ENVIRONMENTAL USA INC	68,338.75
05/29/2024	POOL	667021	017011	ZERO WASTE USA	1,841.40
05/29/2024	POOL	667022	017080	OSBURN INDUSTRIES INC	10,387.34
05/29/2024	POOL	667023	017081	WOMEN LAWYERS ASSOCIATION OF	50.00
05/29/2024	POOL	667024	017085	EVOQUA WATER TECHNOLOGIES	643.86
05/29/2024	POOL	667025	017095	BARUZZINI CONTRACTING LLC	14,921.00
05/29/2024	POOL	667026	017163	THE FLYING LOCKSMITHS	1,330.70
05/29/2024	POOL	667027	017185	THE ASU GROUP	148,827.75
05/29/2024	POOL	667028	017186	T-MOBILE USA INC	827.05
05/29/2024	POOL	667029	017187	BESTES LANDSCAPING SUPPLIES	652.49
05/29/2024	POOL	667030	017233	THE ASU GROUP (SERVICE FEES)	5,680.00
05/29/2024	POOL	667031	017291	CARL F JARBOE	350.00
05/29/2024	POOL	667032	017292	MARK VRANA	930.00
05/29/2024	POOL	667033	017320	DEARBORN NATIONAL LIFE INSURANCE CO	55,131.17
05/29/2024	POOL	667034	017329	R S DALE COMPANY INC	3,823.15
05/29/2024	POOL	667035	017332	LIQUID WEB LLC	2,244.00
05/29/2024	POOL	667036	017338	MICHAEL SYLVESTER	75.00
05/29/2024	POOL	667037	017368	ANGELO DONOFRIO	150.00
05/29/2024	POOL	667038	017404	OFFICE EQUIPMENT RESOURCES INC	118.00
05/29/2024	POOL	667039	017423	ROY SMITH COMPANY	1,473.00
05/29/2024	POOL	667040	017425	MICHELLE LUNDQUIST	480.00
05/29/2024	POOL	667041	017429	LIVE RITE PROPERTIES LLC	540.00
05/29/2024	POOL	667042	017447	MARCO TECHNOLOGIES LLC	178.27
05/29/2024	POOL	667043	017573	AVENTRIC TECHNOLOGIES	639.00
05/29/2024	POOL	667044	017582	MARK ANTHONY CONTRACTING INC	324,360.68
05/29/2024	POOL	667045	017582	MARK ANTHONY CONTRACTING INC	263,745.00
05/29/2024	POOL	667046	017672	CLARISSA CAYTON	108.00
05/29/2024	POOL	667047	017702	NONA AGENCY LLC	588.75
05/29/2024	POOL	667048	017738	PRIORITY WASTE LLC	1,187.12
05/29/2024	POOL	667049	017750	CANIFF ELECTRIC SUPPLY	3,896.09
05/29/2024	POOL	667050	017777	SULTANA CHOWDHURY	250.00
05/29/2024	POOL	667051	017863	S A TORELLO INC	2,122.56
05/29/2024	POOL	667052	017921	GABBARA PROPERTY MANAGEMENT, LLC	3,297.00
05/29/2024	POOL	667053	017934	TRACE ANALYTICAL LABORATORIES INC	50.75
05/29/2024	POOL	667054	018001	AMERICAN PEST CONTROL INC	843.00
05/29/2024	POOL	667055	018014	TEDESCO BUILDING SERVICES INC	6,422.67
05/29/2024	POOL	667056	018042	TARGET SOLUTIONS LEARNING LLC	38,627.98
05/29/2024	POOL	667057	018078	METCOM INC	4,472.10
05/29/2024	POOL	667058	018080	ELLIOTT PROPERTIES LTD LLC	557.00
05/29/2024	POOL	667059	018085	I HEART DOGS RESCUE & ANIMAL HAVEN	1,400.00
05/29/2024	POOL	667060	018093	TARGET SPECIALTY PRODUCTS	700.00
05/29/2024	POOL	667061	018128	TROY A VAN GAMPelaERE	614.00
05/29/2024	POOL	667062	018131	PAUL RETASKIE	103.52
05/29/2024	POOL	667063	018144	HENRY FORD MACOMB HOSP	151.05
05/29/2024	POOL	667064	018157	PAUL JERZY	75.00
05/29/2024	POOL	667065	018158	ANTHONY T SIERACKI JR	75.00
05/29/2024	POOL	667066	018159	CHARLES L PERRY	75.00
05/29/2024	POOL	667067	018161	LLOYD RUDOLPH	75.00
05/29/2024	POOL	667068	018165	AUBURN HILLS LIMITED DIVIDEND	426.00
05/29/2024	POOL	667069	018217	LAWSON PRODUCTS INC	1,010.72
05/29/2024	POOL	667070	018237	VIC BOND SALES INC	1,385.50
05/29/2024	POOL	667071	018239	QUALIFIED CONSTRUCTION CORPORATION	2,703.20
05/29/2024	POOL	667072	018257	DELANO LORD BOWMAN SR	1,510.00
05/29/2024	POOL	667073	018288	GREAT LAKES CONTRACTING SOLUTIONS	200,300.78
05/29/2024	POOL	667074	018329	RPM	145.57
05/29/2024	POOL	667075	018336	COMMERCIAL CONTRACTING CORPORATION	376,295.33
05/29/2024	POOL	667076	018340	DENIS LEDUC	428.82
05/29/2024	POOL	667077	018351	ALBERT M SOPHIEA P.C.	1,600.00
05/29/2024	POOL	667078	018382	AFRIN TRANSLATION INC	197.52
05/29/2024	POOL	667079	018392	TANIA GHANEM	1,575.00
05/29/2024	POOL	667080	018395	TIMMONS GROUP INC	2,681.25
05/29/2024	POOL	667081	018422	ANNMARIE FARCHONE	175.00
05/29/2024	POOL	667082	018431	ASCENTIS CORPORATION	1,465.20
05/29/2024	POOL	667083	018432	PREZZCO INVESTMENTS	586.00
05/29/2024	POOL	667084	018442	SKIP PRINTING COMPANY	2,010.00
05/29/2024	POOL	667085	018452	ARC IMAGING RESOURCES	780.00
05/29/2024	POOL	667086	018478	SUPREME SWEEPING SERVICES INC	450.00
05/29/2024	POOL	667087	018483	JAKAB BONNER	795.28
05/29/2024	POOL	667088	018493	DMC TECHNOLOGY GROUP INC	970.00
05/29/2024	POOL	667089	018498	LINDE GAS & EQUIPMENT INC	234.32
05/29/2024	POOL	667090	018516	FOX POINTE MS LLC	30.00
05/29/2024	POOL	667091	018525	LENOX PROPERTY MANAGEMENT	1,350.00
05/29/2024	POOL	667092	018642	LIMB WALKERS TREE & SNOW	18,415.00
05/29/2024	POOL	667093	018658	THREE PALM TEE'S	574.00
05/29/2024	POOL	667094	018665	ADAM DUFF	89.66
05/29/2024	POOL	667095	018680	JOMANDAETH LLC	576.00
05/29/2024	POOL	667096	018682	THE WASHTUB	36.25
05/29/2024	POOL	667097	018689	PREMIER GROUP ASSOCIATES LC	5,093.00

Check Date	Bank	Check	Vendor	Vendor Name	Amount
05/29/2024	POOL	667098	018736	ODP BUSINESS SOLUTIONS LLC	13,718.04
05/29/2024	POOL	667099	018757	CYLER SCHREINER	77.75
05/29/2024	POOL	667100	018787	DAVID A SOPHIEA	75.00
05/29/2024	POOL	667101	018793	VC3 INC	357.48
05/29/2024	POOL	667102	018858	MACOMB COUNTY HOUSING & RENTALS	2,860.00
05/29/2024	POOL	667103	018877	THE ADAMS GROUP INC	13,646.00
05/29/2024	POOL	667104	018888	KASSEM ZAHER	1,100.00
05/29/2024	POOL	667105	018910	AUBURN HILLS PROPERTY SERVICES LLC	900.00
05/29/2024	POOL	667106	018912	SETCOM	60.00
05/29/2024	POOL	667107	018925	HALLAC PROPERTY MANAGEMENT LLC	2,022.00
05/29/2024	POOL	667108	018936	VERIZON CONNECT FLEET USA LLC	9,380.87
05/29/2024	POOL	667109	018949	MOTION & CONTROL ENTERPRISES LLC	212.76
05/29/2024	POOL	667110	018954	VARIETY FOODSERVICES INC	3,039.68
05/29/2024	POOL	667111	018962	MICHAEL J HENDRICKSON	862.00
05/29/2024	POOL	667112	018970	BMW KAR WASH LLC	118.75
05/29/2024	POOL	667113	018970	BMW KAR WASH LLC	175.75
05/29/2024	POOL	667114	018975	AG MANAGEMENT CO LLC	950.00
05/29/2024	POOL	667115	018980	LAKESHORE JANITORIAL SPECIALIST LLC	1,494.00
05/29/2024	POOL	667116	018988	FORTE APARTMENT MANAGEMENT LLC	498.00
05/29/2024	POOL	667117	019022	PAULA M SAUBER	585.00
05/29/2024	POOL	667118	019056	KFH LLC	690.00
05/29/2024	POOL	667119	019083	ROWLEYS WHOLESALE	1,498.82
05/29/2024	POOL	667120	019084	USABLUEBOOK	10,732.73
05/29/2024	POOL	667121	019099	FRASER POINTE MANOR APARTMENTS	869.00
05/29/2024	POOL	667122	019107	AMAZON CAPITAL SERVICES INC	318.94
05/29/2024	POOL	667123	019108	FRIENDLY CHRYSLER JEEP	760.40
05/29/2024	POOL	667124	019116	EASTPOINTE ANIMAL HOSPITAL	142.00
05/29/2024	POOL	667125	019117	KLOCHKO EQUIPMENT RENTAL COMPANY	902.94
05/29/2024	POOL	667126	019119	MODERN PRINTING SERVICES INC	100.00
05/29/2024	POOL	667127	019134	EUROFINS ENVIRONMENT TESTING	401.50
05/29/2024	POOL	667128	019147	BRADLEY G SMITH	820.00
05/29/2024	POOL	667129	019159	PERNICANO LAW PLLC	1,695.00
05/29/2024	POOL	667130	019166	ALFRED JONES III	3,250.00
05/29/2024	POOL	667131	019166	ALFRED JONES III	3,250.00
05/29/2024	POOL	667132	019196	BDP CC LLC	661.00
05/29/2024	POOL	667133	019197	GREAT LAKES PROPERTY MGMT CO LLC	646.00
05/29/2024	POOL	667134	019267	HP LIMITED DIVIDEND HOUSING	944.00
05/29/2024	POOL	667135	019271	REE LLC	1,100.00
05/29/2024	POOL	667136	019277	HEIGHTS OF SOUTHFIELD LLC	2,506.00
05/29/2024	POOL	667137	019290	MIMG XLIII WARREN CLUB, LLC	975.00
05/29/2024	POOL	667138	019300	ADVANCED IT PROFESSIONALS LLC	150.00
05/29/2024	POOL	667139	019303	DONALD K ROSS	200.00
05/29/2024	POOL	667140	019329	GEORGE TATARYN	1,023.00
05/29/2024	POOL	667141	019330	MD H RAHMAN	767.00
05/29/2024	POOL	667142	019331	ATN HOME TECHNOLOGY LLC	984.00
05/29/2024	POOL	667143	019333	RS AMERICAS INC	481.20
05/29/2024	POOL	667144	019337	JUDITH M MALINOWSKI	1,000.00
05/29/2024	POOL	667145	019342	HEARTS FOR HOMES INC	5,576.90
05/29/2024	POOL	667146	019344	SANTORO SERVICES LLC	24,450.00
05/29/2024	POOL	667147	019346	YVETTE BARRETT	480.00
05/29/2024	POOL	667148	019370	LYNN FRANCIS	232.00
05/29/2024	POOL	667149	019371	LAFAYETTE PLACE LOFTS LLC	267.00
05/29/2024	POOL	667150	019377	ADRIANA ROSE PICCIRILLI	270.00
05/29/2024	POOL	667151	019393	BIG BARNEY'S ROAD MAINTENANCE	9,802.00
05/29/2024	POOL	667152	019406	GREAT LAKES MULTIMEDIA SUPPLY INC	4,140.00
05/29/2024	POOL	667153	019408	PI-LIT TECHNOLOGIES	1,523.00
05/29/2024	POOL	667154	019421	SHAWN ABBASI	100.00
05/29/2024	POOL	667155	019428	ACLARA TECHNOLOGIES LLC	5,854.50
05/29/2024	POOL	667156	019429	MOTOR CITY INDUSTRIAL	9.49
05/29/2024	POOL	667157	019434	NINA WARDA	750.00
05/29/2024	POOL	667158	019437	COUNTY OF LAPEER	300.00
05/29/2024	POOL	667159	019445	PAUL BUKOWSKI	150.00
05/29/2024	POOL	667160	019447	JB ROAD REPAIR	4,250.00
05/29/2024	POOL	667161	019454	OUR MEDIA LLC	19.95
05/29/2024	POOL	667162	019455	DOLORES A HAYNES	1,100.00
05/29/2024	POOL	667163	019467	MACQUEEN	28,728.67
05/29/2024	POOL	667164	019468	RICHELIEU AMERICA LTD	185.59
05/29/2024	POOL	667165	019473	VERSATERM PUBLIC SAFETY US INC	4,369.68
05/29/2024	POOL	667166	019475	GANESH REALTY LLC	584.00
05/29/2024	POOL	667167	019476	VICTORIA YASKANIN	1,676.00
05/29/2024	POOL	667168	019477	WHITE LAKE RESIDENCE LLC	827.00
05/29/2024	POOL	667169	019489	DAVID R DRAPER	700.00
05/29/2024	POOL	667170	019490	RICHARD WYGONIK	426.50
05/29/2024	POOL	667171	019492	COURTNEY RAJTER	50.17
05/29/2024	POOL	667172	019493	MICHAEL SWAFFORD	1,170.00
05/29/2024	POOL	667173	019499	RICHARD MORROW	25.00
05/29/2024	POOL	667174	070515	ALANA JANNETTE	143.12
05/29/2024	POOL	667175	080000	LOCAL 412	1,686.75
05/29/2024	POOL	667176	080005	FOP LODGE 124	3,285.00
05/29/2024	POOL	667177	080006	INT ASSOC OF FIREFIGHTERS	14,800.81
05/29/2024	POOL	667178	080007	WARREN FIRE FIGHTER FUND	1,330.00

Check Date	Bank	Check	Vendor	Vendor Name	Amount
05/29/2024	POOL	667179	080023	DENCAP	1,483.20
05/29/2024	POOL	667180	080100	DELTA DENTAL OF MICHIGAN	18,943.51
05/29/2024	POOL	667181	080101	DELTA DENTAL OF MICHIGAN	31,093.15
05/29/2024	POOL	667182	080220	WARREN SUPERVISORS	2,520.00
05/29/2024	POOL	667183	099998	TINA M PERSHA MA LPC	300.00
05/29/2024	POOL	667184	099998	TINA M PERSHA MA LPC	300.00
05/29/2024	POOL	667185	099998	MOHAMMED AL LLAMI	31.80
05/29/2024	POOL	667186	099998	DAWSON BAILEY	39.10
05/29/2024	POOL	667187	099998	BRUCE BENDES	37.90
05/29/2024	POOL	667188	099998	BARBARA BRECHT	40.70
05/29/2024	POOL	667189	099998	CARLTON CARTER	39.90
05/29/2024	POOL	667190	099998	LAURA DECARLO	53.30
05/29/2024	POOL	667191	099998	CODY DULECKI	56.50
05/29/2024	POOL	667192	099998	KELLY FRIEND	40.30
05/29/2024	POOL	667193	099998	ELVIRA GRAFILO	17.00
05/29/2024	POOL	667194	099998	AMBER HARVEY	41.90
05/29/2024	POOL	667195	099998	NANCY KHOSHABA	40.70
05/29/2024	POOL	667196	099998	JUSTIN LIPINSKI	39.10
05/29/2024	POOL	667197	099998	GABRIEL MARTINEZ	39.10
05/29/2024	POOL	667198	099998	RONALD MESIC JR	38.30
05/29/2024	POOL	667199	099998	JEFFREY OCHALEK	52.90
05/29/2024	POOL	667200	099998	MICHAEL PEDICA	41.10
05/29/2024	POOL	667201	099998	EDWINA QUIAZON	39.90
05/29/2024	POOL	667202	099998	TONIE ROLAND	16.20
05/29/2024	POOL	667203	099998	MARK SCHERMERHORN	42.30
05/29/2024	POOL	667204	099998	LINDA STEVENS	55.70
05/29/2024	POOL	667205	099998	COLLEEN THOMAS-SCHRAM	16.20
05/29/2024	POOL	667206	099998	DONIYA VARGHESE	31.00
05/29/2024	POOL	667207	099998	RICHARD WIETNIK	43.50
05/29/2024	POOL	667208	099998	SHIRLEY WOZNIAK	40.70
05/29/2024	POOL	667209	099998	FORREST CRYDERMAN	96.42
05/29/2024	POOL	667210	099998	SFR3 LLC	61.11
05/29/2024	POOL	667211	099998	WALLSIDE WINDOWS INC	122.00
05/29/2024	POOL	667212	099998	RESTAURANT BRAND INTERNATIONAL	300.00
05/29/2024	POOL	667213	099998	READY ROOTER GROUP	1,090.50
05/29/2024	POOL	667214	099998	ESTATE OF LYDIA GRILLO	295.00
05/29/2024	POOL	667215	099998	MACOMB COUNTY TREASURER	469.29
05/29/2024	POOL	667216	099998	MACOMB COUNTY TREASURER	91.58
05/29/2024	POOL	667217	099998	KAREN DAY	15.99
05/29/2024	POOL	667218	004924	FERGUSON WATERWORKS	10,832.14
05/29/2024	POOL	667219	011088	OWEN TREE SERVICE INC	206,190.86
05/29/2024	POOL	667220	011091	WOLVERINE FREIGHTLINER EASTSIDE INC	391.69
05/29/2024	POOL	667221	013932	GARRETT DOOR CO	9,021.45
05/29/2024	POOL	667222	014756	CREST FORD INC	1,907.55
05/29/2024	POOL	667223	015304	MACOMB COMMUNITY COLLEGE	3,900.00
05/29/2024	POOL	667224	015678	KIESLER POLICE SUPPLY INC	2,675.80
05/29/2024	POOL	667225	016177	USA PLUMBING	1,526.50
05/29/2024	POOL	667226	016401	COMMPAR LLC	1,797.82
05/29/2024	POOL	667227	016454	SCI FLOOR COVERING INC	200.00

POOL TOTALS:

Total of 451 Checks:	4,358,209.25
Less 0 Void Checks:	0.00
Total of 451 Disbursements:	<u>4,358,209.25</u>

Check Date	Bank	Check #	Payee	Description	Account	Dept	Amount
Fund: 101 GENERAL FUND							
Department: 0000							
05/09/2024	POOL	666787	SPARTAN PAVING LLC	ESCROW REFUND 22-5597	25603	0000	643.00
05/16/2024	POOL	666788*#	DTE ENERGY	ELECTRIC SERVICE	09495	0000	17.63
05/16/2024	POOL	666791#	AT&T MOBILITY	CELLULAR EQUIPMENT	09494	0000	11,379.62
05/29/2024	POOL	666807	ALLIE BROTHERS INC	CLOTHING ALLOWANCE	20286	0000	169.98
				CLOTHING ALLOWANCE	20286	0000	20.00
				CLOTHING ALLOWANCE	20286	0000	14.00
				CLOTHING ALLOWANCE	20286	0000	42.00
				CLOTHING ALLOWANCE	20286	0000	7.50
				CLOTHING ALLOWANCE	20286	0000	133.98
				CLOTHING ALLOWANCE	20286	0000	15.99
				CLOTHING ALLOWANCE	20286	0000	27.99
				CLOTHING ALLOWANCE	20286	0000	35.00
				CLOTHING ALLOWANCE	20286	0000	60.00
				CLOTHING ALLOWANCE	20286	0000	59.96
				CLOTHING ALLOWANCE	20286	0000	99.99
				CLOTHING ALLOWANCE	20286	0000	84.99
				CLOTHING ALLOWANCE	20286	0000	55.96
				CLOTHING ALLOWANCE	20286	0000	6.00
				CLOTHING ALLOWANCE	20286	0000	80.00
				CLOTHING ALLOWANCE	20286	0000	3.00
				CLOTHING ALLOWANCE	20286	0000	49.99
				CLOTHING ALLOWANCE	20286	0000	108.99
				CLOTHING ALLOWANCE	20286	0000	29.98
				CLOTHING ALLOWANCE	20286	0000	32.98
				CLOTHING ALLOWANCE	20286	0000	169.98
				CLOTHING ALLOWANCE	20286	0000	38.99
				CLOTHING ALLOWANCE	20286	0000	100.00
				CLOTHING ALLOWANCE	20286	0000	10.00
				CLOTHING ALLOWANCE	20286	0000	0.93
				CLOTHING ALLOWANCE	20286	0000	3.75
				CLOTHING ALLOWANCE	20286	0000	15.99
				CLOTHING ALLOWANCE	20286	0000	36.00
				CLOTHING ALLOWANCE	20286	0000	48.99
				CLOTHING ALLOWANCE	20286	0000	29.99
				CLOTHING ALLOWANCE	20286	0000	66.99
CHECK POOL 666807 TOTAL FOR FUND 101:							1,659.89

Check Date	Bank	Check #	Payee	Description	Account	Dept	Amount
Fund: 101 GENERAL FUND							
Department: 0000							
05/29/2024	POOL	666893*#	GORDON FOOD SERVICE INC	FOOD/REFRESHMENTS	20205	0000	357.07
				FOOD/REFRESHMENTS	20205	0000	124.85
				CHECK POOL 666893 TOTAL FOR FUND 101:			<u>481.92</u>
05/29/2024	POOL	666925	DETROIT SALT	ROCK SALT	10900	0000	15,547.24
				ROCK SALT	10900	0000	3,000.88
				ROCK SALT	10900	0000	3,136.74
				ROCK SALT	10900	0000	9,239.04
				ROCK SALT	10900	0000	6,087.94
				ROCK SALT	10900	0000	6,042.45
				CHECK POOL 666925 TOTAL FOR FUND 101:			<u>43,054.29</u>
05/29/2024	POOL	666969	COMPONE ADMINISTRATORS	WORKERS COMPENSATION	20524	0000	2,118.30
				WORKERS COMPENSATION	20524	0000	12,063.93
				CHECK POOL 666969 TOTAL FOR FUND 101:			<u>14,182.23</u>
05/29/2024	POOL	666993	WOW! INTERNET CABLE PHONE	INTERNET SERVICE	12300	0000	626.16
				CABLE SERVICE	12300	0000	1,281.96
				CHECK POOL 666993 TOTAL FOR FUND 101:			<u>1,908.12</u>
05/29/2024	POOL	666997*#	WOW! BUSINESS	HIGH SPEED INTERNET SERVICE	12300	0000	1,355.88
05/29/2024	POOL	667022*#	OSBURN INDUSTRIES INC	SLAG, SAND & AGGREGATES	10900	0000	4,969.20
05/29/2024	POOL	667027#	THE ASU GROUP	LOSS FUND REIMBURSEMENT	12400	0000	(29,120.30)
				LOSS FUND REIMBURSEMENT	12400	0000	(14,002.00)
				LOSS FUND REIMBURSEMENT	12400	0000	(35,108.91)
				LOSS FUND REIMBURSEMENT	12400	0000	(13,693.13)
				CHECK POOL 667027 TOTAL FOR FUND 101:			<u>(91,924.34)</u>
05/29/2024	POOL	667110#	VARIETY FOODSERVICES INC	FOOD/REFRESHMENTS	20205	0000	920.00
05/29/2024	POOL	667160	JB ROAD REPAIR	EMULSION	10900	0000	4,250.00
05/29/2024	POOL	667165	VERSATERM PUBLIC SAFETY US INC	SOFTWARE LICENSE	12300	0000	1,747.87
				SOFTWARE LICENSE	12300	0000	2,621.81
				CHECK POOL 667165 TOTAL FOR FUND 101:			<u>4,369.68</u>

Check Date	Bank	Check #	Payee	Description	Account	Dept	Amount
Fund: 101 GENERAL FUND							
Department: 0000							
05/29/2024	POOL	667174	ALANA JANNETTE	PLAINCLOTHES EXPENDITURES	20289	0000	143.12
05/29/2024	POOL	667180#	DELTA DENTAL OF MICHIGAN	RETIREES DENTAL INSURANCE	23104	0000	9,460.39
05/29/2024	POOL	667181#	DELTA DENTAL OF MICHIGAN	P&F RETIREES DENTAL	23104	0000	1,412.50
				P&F RETIREES DENTAL	23104	0000	38.14
				P&F RETIREES DENTAL	23104	0000	2,452.15
				P&F RETIREES DENTAL	23104	0000	168.13
				P&F RETIREES DENTAL	23104	0000	11,400.46
				P&F RETIREES DENTAL	23124	0000	86.96
				CHECK POOL 667181 TOTAL FOR FUND 101:			<u>15,558.34</u>
05/29/2024	POOL	667213	READY ROOTER GROUP	ESCROW REFUND 23-5776	25603	0000	1,090.50
				Total for department 0000:			23,519.47
Department: 0080 REVENUES							
05/29/2024	POOL	666883	MICHIGAN DEPT OF TREASURY	ABANDONED VEHICLE EXCESS	63800	0080	2,355.00
05/29/2024	POOL	667211	WALLSIDE WINDOWS INC	BUILDING/ZONING/ONLINE PERMIT REFUND	47800	0080	80.00
				BUILDING/ZONING/ONLINE PERMIT REFUND	48500	0080	2.00
				BUILDING/ZONING/ONLINE PERMIT REFUND	48600	0080	40.00
				CHECK POOL 667211 TOTAL FOR FUND 101:			<u>122.00</u>
05/29/2024	POOL	667216	MACOMB COUNTY TREASURER	HOMESTEAD EXEMPTION	44500	0080	77.47
				HOMESTEAD EXEMPTION	60900	0080	14.11
				CHECK POOL 667216 TOTAL FOR FUND 101:			<u>91.58</u>
				Total for department 0080:			2,568.58
Department: 1101 COUNCIL							
05/09/2024	POOL	666781*#	WINDSTREAM COMMUNICATIONS INC	TELEPHONE SERVICE	85300	1101	27.08
05/29/2024	POOL	666986*#	APPLIED INNOVATION	COPIER MAINTENANCE	80100	1101	141.60
05/29/2024	POOL	667033*#	DEARBORN NATIONAL LIFE INSURANCE	LIFE AND AD&D PREMIUM	71900	1101	255.15
				DISABILITY PREMIUM	71900	1101	89.32
				LONG TERM DISABILITY PREMIUM	71900	1101	24.91
				CHECK POOL 667033 TOTAL FOR FUND 101:			<u>369.38</u>
				Total for department 1101:			538.06

Check Date	Bank	Check #	Payee	Description	Account	Dept	Amount
Fund: 101 GENERAL FUND							
Department: 1136 37TH DISTRICT COURT							
05/09/2024	POOL	666781*#	WINDSTREAM COMMUNICATIONS INC	TELEPHONE SERVICE	85300	1136	1,355.75
05/09/2024	POOL	666786*#	DENCAP	DENTAL PREMIUMS	71900	1136	114.00
05/16/2024	POOL	666792*#	VERIZON WIRELESS	CELLULAR SERVICE	85300	1136	180.05
05/16/2024	POOL	666804	RUSSELL HANSEN	JURY DUTY	83500	1136	16.00
05/29/2024	POOL	666812	DES MOINES STAMP MFG CO	OFFICE SUPPLY	72700	1136	51.55
				OFFICE SUPPLY	72700	1136	50.15
				CHECK POOL 666812 TOTAL FOR FUND 101:			<u>101.70</u>
05/29/2024	POOL	666835*#	CITY OF WARREN	WATER SERVICE	92000	1136	423.96
				WATER SERVICE	92000	1136	27.46
				CHECK POOL 666835 TOTAL FOR FUND 101:			<u>451.42</u>
05/29/2024	POOL	666839#	WEST GROUP	ONLINE SERVICE	98200	1136	306.99
				BOOKS	98200	1136	396.25
				ONLINE SERVICE	98200	1136	447.84
				CHECK POOL 666839 TOTAL FOR FUND 101:			<u>1,151.08</u>
05/29/2024	POOL	666885*#	DAWN M WALTON	TRAVEL EXPENSE	82248	1136	118.05
				TRAVEL EXPENSE	82249	1136	111.25
				CHECK POOL 666885 TOTAL FOR FUND 101:			<u>229.30</u>
05/29/2024	POOL	666887	TARGET INFORMATION	OFFICE SUPPLY	72700	1136	203.40
05/29/2024	POOL	666895	AMERI TIME LLC	RIBBON	80100	1136	24.00
				RIBBON	80100	1136	14.20
				MAINTENANCE AGREEMENT	80100	1136	310.00
				CHECK POOL 666895 TOTAL FOR FUND 101:			<u>348.20</u>
05/29/2024	POOL	666908	LORAIN C KENNY	COURT RECORDING SERVICE	80100	1136	400.00
05/29/2024	POOL	666913*#	GOV CONNECTION INC	COMPUTER SUPPLY	72700	1136	411.36
05/29/2024	POOL	666916	JESSICA R BROWN	COURT RECORDING SERVICES	80100	1136	175.00

Check Date	Bank	Check #	Payee	Description	Account	Dept	Amount
Fund: 101 GENERAL FUND							
Department: 1136 37TH DISTRICT COURT							
05/29/2024	POOL	666931	COMPLETION HOUSE	DRUG COURT RESIDENTIAL TREATMENT	82248	1136	2,700.00
05/29/2024	POOL	666940	SHREDCORP	DOCUMENT SHREDDING	80100	1136	84.00
				DOCUMENT SHREDDING	80100	1136	40.00
				CHECK POOL 666940 TOTAL FOR FUND 101:			<u>124.00</u>
05/29/2024	POOL	666956	DONNA CILLUFFO	TRAVEL EXPENSE	82248	1136	29.52
				TRAVEL EXPENSE	82249	1136	123.75
				CHECK POOL 666956 TOTAL FOR FUND 101:			<u>153.27</u>
05/29/2024	POOL	666986*#	APPLIED INNOVATION	COPIER MAINTENANCE	80100	1136	52.15
				COPIER MAINTENANCE	80100	1136	19.67
				COPIER MAINTENANCE	80100	1136	28.32
				COPIER MAINTENANCE	80100	1136	30.00
				COPIER MAINTENANCE	80100	1136	67.96
				COPIER MAINTENANCE	80100	1136	33.84
				DRUG COURT COPIER MAINTENANCE	82210	1136	14.71
				CHECK POOL 666986 TOTAL FOR FUND 101:			<u>246.65</u>
05/29/2024	POOL	666992	INTEGRITY BUSINESS SOLUTIONS	OFFICE SUPPLIES	72700	1136	349.90
				OFFICE SUPPLIES	72700	1136	399.90
				CHECK POOL 666992 TOTAL FOR FUND 101:			<u>749.80</u>
05/29/2024	POOL	666999	LINGUISTICA INTERNATIONAL	INTERPRETING SERVICE	80100	1136	19.20
05/29/2024	POOL	667000	WORLDWIDE INTERPRETERS	INTERPRETING SERVICE	80100	1136	211.75
				INTERPRETING SERVICE	80100	1136	269.12
				INTERPRETING SERVICE	80100	1136	225.15
				CHECK POOL 667000 TOTAL FOR FUND 101:			<u>706.02</u>
05/29/2024	POOL	667003	DR RONALD FENTON	DRUG COURT EVALUATOR	82248	1136	1,250.00
05/29/2024	POOL	667004	CLASS 'A' TRAINING CENTER	DRUG COURT DRUG TESTING	82248	1136	9,540.00
				DRUG COURT CLASSES	82249	1136	1,320.00
				CHECK POOL 667004 TOTAL FOR FUND 101:			<u>10,860.00</u>
05/29/2024	POOL	667011	SIGNING PROS LLC	INTERPRETING SERVICE	80100	1136	215.00

Check Date	Bank	Check #	Payee	Description	Account	Dept	Amount
Fund: 101 GENERAL FUND							
Department: 1136 37TH DISTRICT COURT							
05/29/2024	POOL	667017	FIVE STAR LANGUAGES	INTERPRETING SERVICE	80100	1136	180.00
				INTERPRETING SERVICE	80100	1136	160.00
				INTERPRETING SERVICE	80100	1136	160.00
				INTERPRETING SERVICE	80100	1136	160.00
				CHECK POOL 667017 TOTAL FOR FUND 101:			<u>660.00</u>
05/29/2024	POOL	667023	WOMEN LAWYERS ASSOCIATION OF	WLAM MEMBERSHIP	95800	1136	50.00
05/29/2024	POOL	667031	CARL F JARBOE	VISITING JUDGE	80103	1136	350.00
05/29/2024	POOL	667033*#	DEARBORN NATIONAL LIFE INSURANCE	LIFE AND AD&D PREMIUM	71900	1136	957.56
				DISABILITY PREMIUM	71900	1136	1,685.81
				LONG TERM DISABILITY PREMIUM	71900	1136	447.06
				CHECK POOL 667033 TOTAL FOR FUND 101:			<u>3,090.43</u>
05/29/2024	POOL	667041	LIVE RITE PROPERTIES LLC	DRUG COURT 3/4 HOUSING	82249	1136	540.00
05/29/2024	POOL	667047	NONA AGENCY LLC	INTERPRETING SERVICE	80100	1136	588.75
05/29/2024	POOL	667057	METCOM INC	COURT FORMS	72700	1136	3,350.50
				COURT FORMS	72700	1136	166.15
				COURT FORMS	72700	1136	955.45
				CHECK POOL 667057 TOTAL FOR FUND 101:			<u>4,472.10</u>
05/29/2024	POOL	667076	DENIS LEDUC	VISITING JUDGE	80103	1136	428.82
05/29/2024	POOL	667077	ALBERT M SOPHIEA P.C.	MAGISTRATE/HEARING OFFICER	80103	1136	500.00
				MAGISTRATE/HEARING OFFICER	80103	1136	300.00
				MAGISTRATE/HEARING OFFICER	80103	1136	300.00
				MAGISTRATE/HEARING OFFICER	80103	1136	500.00
				CHECK POOL 667077 TOTAL FOR FUND 101:			<u>1,600.00</u>
05/29/2024	POOL	667078	AFRIN TRANSLATION INC	INTERPRETING SERVICE	80100	1136	197.52
05/29/2024	POOL	667079	TANIA GHANEM	INTERPRETATION SERVICES	80100	1136	175.00
				INTERPRETATION SERVICES	80100	1136	175.00
				INTERPRETATION SERVICES	80100	1136	175.00
				INTERPRETATION SERVICES	80100	1136	175.00
				INTERPRETATION SERVICES	80100	1136	175.00
				INTERPRETATION SERVICES	80100	1136	175.00
				INTERPRETATION SERVICES	80100	1136	350.00
				INTERPRETATION SERVICES	80100	1136	175.00
				INTERPRETATION SERVICES	80100	1136	175.00

Check Date	Bank	Check #	Payee	Description	Account	Dept	Amount
Fund: 101 GENERAL FUND							
Department: 1136 37TH DISTRICT COURT							
CHECK POOL 667079 TOTAL FOR FUND 101:							1,575.00
05/29/2024	POOL	667081	ANMARIE FARCHONE	COURT RECORDING SERVICES	80100	1136	175.00
05/29/2024	POOL	667098*#	ODP BUSINESS SOLUTIONS LLC	OFFICE SUPPLY	72700	1136	46.38
				OFFICE SUPPLY	72700	1136	127.30
				OFFICE SUPPLY	72700	1136	103.83
				OFFICE SUPPLY	72700	1136	37.61
				OFFICE SUPPLY	72700	1136	55.51
				OFFICE SUPPLY	72700	1136	71.76
				OFFICE SUPPLY	72700	1136	37.61
				OFFICE SUPPLY	72700	1136	27.29
				OFFICE SUPPLY	72700	1136	26.98
				OFFICE SUPPLY	72700	1136	11.69
				OFFICE SUPPLY	72700	1136	360.16
				OFFICE SUPPLY	72700	1136	19.98
				OFFICE SUPPLY	72700	1136	64.55
				OFFICE SUPPLY	72700	1136	52.98
				OFFICE SUPPLY	72700	1136	152.88
				OFFICE SUPPLY	72700	1136	35.85
				OFFICE SUPPLY	72700	1136	41.92
				OFFICE SUPPLY	72700	1136	24.99
				OFFICE SUPPLY	72700	1136	309.54
				OFFICE SUPPLY	72700	1136	102.30
CHECK POOL 667098 TOTAL FOR FUND 101:							1,711.11
05/29/2024	POOL	667101	VC3 INC	IT SERVICES	80100	1136	357.48
05/29/2024	POOL	667117	PAULA M SAUBER	CONTRACTUAL SERVICES	80100	1136	279.00
				CONTRACTUAL SERVICES	80100	1136	306.00
CHECK POOL 667117 TOTAL FOR FUND 101:							585.00
05/29/2024	POOL	667126	MODERN PRINTING SERVICES INC	COURT FORMS	72700	1136	100.00
05/29/2024	POOL	667161	HOUR MEDIA LLC	HOUR DETROIT SUBSCRIPTION	95800	1136	19.95
05/29/2024	POOL	667169	DAVID R DRAPER	VISITING JUDGE	80103	1136	700.00
05/29/2024	POOL	667170	RICHARD WYGONIK	VISITING JUDGE	80103	1136	426.50
05/29/2024	POOL	667185	MOHAMMED AL LLAMI	JURY DUTY	83500	1136	31.80
05/29/2024	POOL	667186	DAWSON BAILEY	JURY DUTY	83500	1136	39.10
05/29/2024	POOL	667187	BRUCE BENDES	JURY DUTY	83500	1136	37.90

Check Date	Bank	Check #	Payee	Description	Account	Dept	Amount
Fund: 101 GENERAL FUND							
Department: 1136 37TH DISTRICT COURT							
05/29/2024	POOL	667188	BARBARA BRECHT	JURY DUTY	83500	1136	40.70
05/29/2024	POOL	667189	CARLTON CARTER	JURY DUTY	83500	1136	39.90
05/29/2024	POOL	667190	LAURA DECARLO	JURY DUTY	83500	1136	53.30
05/29/2024	POOL	667191	CODY DULECKI	JURY DUTY	83500	1136	56.50
05/29/2024	POOL	667192	KELLY FRIEND	JURY DUTY	83500	1136	40.30
05/29/2024	POOL	667193	ELVIRA GRAFILO	JURY DUTY	83500	1136	17.00
05/29/2024	POOL	667194	AMBER HARVEY	JURY DUTY	83500	1136	41.90
05/29/2024	POOL	667195	NANCY KHOSHABA	JURY DUTY	83500	1136	40.70
05/29/2024	POOL	667196	JUSTIN LIPINSKI	JURY DUTY	83500	1136	39.10
05/29/2024	POOL	667197	GABRIEL MARTINEZ	JURY DUTY	83500	1136	39.10
05/29/2024	POOL	667198	RONALD MESIC JR	JURY DUTY	83500	1136	38.30
05/29/2024	POOL	667199	JEFFREY OCHALEK	JURY DUTY	83500	1136	52.90
05/29/2024	POOL	667200	MICHAEL PEDICA	JURY DUTY	83500	1136	41.10
05/29/2024	POOL	667201	EDWINA QUIAZON	JURY DUTY	83500	1136	39.90
05/29/2024	POOL	667202	TONIE ROLAND	JURY DUTY	83500	1136	16.20
05/29/2024	POOL	667203	MARK SCHERMERHORN	JURY DUTY	83500	1136	42.30
05/29/2024	POOL	667204	LINDA STEVENS	JURY DUTY	83500	1136	55.70
05/29/2024	POOL	667205	COLLEEN THOMAS-SCHRAM	JURY DUTY	83500	1136	16.20
05/29/2024	POOL	667206	DONIYA VARGHESE	JURY DUTY	83500	1136	31.00
05/29/2024	POOL	667207	RICHARD WIETNIK	JURY DUTY	83500	1136	43.50
05/29/2024	POOL	667208	SHIRLEY WOZNIAK	JURY DUTY	83500	1136	40.70
Total for department 1136:							40,723.96
Department: 1171 MAYOR							
05/29/2024	POOL	666945	DIGIGRAPHX	BANNERS	72700	1171	235.00
				BANNERS	72700	1171	45.00
CHECK POOL 666945 TOTAL FOR FUND 101:							280.00
05/29/2024	POOL	666986*#	APPLIED INNOVATION	COPIER MAINTENANCE	80100	1171	334.71

05/22/2024 11:26 AM
 User: tcameron
 DB: Warren

CHECK DISBURSEMENT REPORT FOR CITY OF WARREN
 CHECK NUMBER 666777 - 667227

Check Date	Bank	Check #	Payee	Description	Account	Dept	Amount
Fund: 101 GENERAL FUND							
Department: 1171 MAYOR							
05/29/2024	POOL	667033*#	DEARBORN NATIONAL LIFE INSURANCE	LIFE AND AD&D PREMIUM	71900	1171	146.82
				DISABILITY PREMIUM	71900	1171	191.85
				LONG TERM DISABILITY PREMIUM	71900	1171	53.50
				CHECK POOL 667033 TOTAL FOR FUND 101:			<u>392.17</u>
05/29/2024	POOL	667098*#	ODP BUSINESS SOLUTIONS LLC	OFFICE SUPPLY	72700	1171	138.88
				OFFICE SUPPLY	72700	1171	72.26
				OFFICE SUPPLY	72700	1171	113.42
				OFFICE SUPPLY	72700	1171	10.23
				OFFICE SUPPLY	72700	1171	12.40
				OFFICE SUPPLY	72700	1171	195.10
				CHECK POOL 667098 TOTAL FOR FUND 101:			<u>542.29</u>
				Total for department 1171:			1,549.17
Department: 1209 ASSESSING							
05/09/2024	POOL	666786*#	DENCAP	DENTAL PREMIUMS	71900	1209	57.00
05/29/2024	POOL	666839#	WEST GROUP	SUBSCRIPTION	83300	1209	650.00
05/29/2024	POOL	666966	COSTAR REALTY INFORMATION	ONLINE SERVICE	80106	1209	1,156.68
05/29/2024	POOL	666986*#	APPLIED INNOVATION	COPIER MAINTENANCE	83300	1209	267.57
				COPIER MAINTENANCE	83300	1209	385.68
				CHECK POOL 666986 TOTAL FOR FUND 101:			<u>653.25</u>
05/29/2024	POOL	667006#	MICHAEL FONTANA	REIMBURSEMENT	83300	1209	350.00
05/29/2024	POOL	667033*#	DEARBORN NATIONAL LIFE INSURANCE	LIFE AND AD&D PREMIUM	71900	1209	225.85
				DISABILITY PREMIUM	71900	1209	422.36
				LONG TERM DISABILITY PREMIUM	71900	1209	100.06
				CHECK POOL 667033 TOTAL FOR FUND 101:			<u>748.27</u>
05/29/2024	POOL	667084*#	SKIP PRINTING COMPANY	PRINTING	72700	1209	420.00
				PRINTING	72700	1209	395.00
				CHECK POOL 667084 TOTAL FOR FUND 101:			<u>815.00</u>
05/29/2024	POOL	667098*#	ODP BUSINESS SOLUTIONS LLC	OFFICE SUPPLY	72700	1209	62.21

Check Date	Bank	Check #	Payee	Description	Account	Dept	Amount
Fund: 101 GENERAL FUND							
Department: 1209 ASSESSING							
				OFFICE SUPPLY	72700	1209	68.75
				OFFICE SUPPLY	72700	1209	25.17
				OFFICE SUPPLY	72700	1209	1,599.98
				OFFICE SUPPLY	72700	1209	89.09
				OFFICE SUPPLY	72700	1209	32.99
				OFFICE SUPPLY	72700	1209	25.49
				OFFICE SUPPLY	72700	1209	79.98
				CHECK POOL 667098 TOTAL FOR FUND 101:			<u>1,983.66</u>
				Total for department 1209:			6,413.86
Department: 1210 LEGAL							
05/09/2024	POOL	666786*#	DENCAP	DENTAL PREMIUMS	71900	1210	57.00
05/29/2024	POOL	666809	BURWOOD BUSINESS MACHINES	PRINTER MAINTENANCE	80100	1210	138.00
05/29/2024	POOL	666818*#	FEDERAL EXPRESS CORP	SHIPPING SERVICE	80100	1210	76.52
05/29/2024	POOL	666824	ICLE	BOOKS	95800	1210	148.50
05/29/2024	POOL	666836	CITY OF WARREN	PETTY CASH	82600	1210	5.00
				PETTY CASH	86100	1210	30.85
				CHECK POOL 666836 TOTAL FOR FUND 101:			<u>35.85</u>
05/29/2024	POOL	666839#	WEST GROUP	BOOKS	95800	1210	7,301.00
05/29/2024	POOL	666986*#	APPLIED INNOVATION	COPIER MAINTENANCE	80100	1210	32.26
05/29/2024	POOL	667033*#	DEARBORN NATIONAL LIFE INSURANCE	LIFE AND AD&D PREMIUM	71900	1210	215.78
				DISABILITY PREMIUM	71900	1210	404.25
				LONG TERM DISABILITY PREMIUM	71900	1210	88.31
				CHECK POOL 667033 TOTAL FOR FUND 101:			<u>708.34</u>
05/29/2024	POOL	667098*#	ODP BUSINESS SOLUTIONS LLC	OFFICE SUPPLY	72700	1210	115.80
				OFFICE SUPPLY	72700	1210	115.80
				CHECK POOL 667098 TOTAL FOR FUND 101:			<u>231.60</u>
				Total for department 1210:			8,729.07
Department: 1215 CLERK							

05/22/2024 11:26 AM
User: tcameron
DB: Warren

CHECK DISBURSEMENT REPORT FOR CITY OF WARREN
CHECK NUMBER 666777 - 667227

Check Date	Bank	Check #	Payee	Description	Account	Dept	Amount
Fund: 101 GENERAL FUND							
Department: 1215 CLERK							
05/09/2024	POOL	666786*#	DENCAP	DENTAL PREMIUMS	71900	1215	57.00
05/29/2024	POOL	666886*#	HOME DEPOT CREDIT SERVICE	MAINTENANCE SUPPLY	72700	1215	349.80
				MAINTENANCE SUPPLY	72700	1215	224.90
				CREDIT MEMO	72700	1215	(139.92)
				CREDIT MEMO	72700	1215	(34.98)
				CHECK POOL 666886 TOTAL FOR FUND 101:			<u>399.80</u>
05/29/2024	POOL	666986*#	APPLIED INNOVATION	COPIER MAINTENANCE	80100	1215	61.65
05/29/2024	POOL	667007*#	21ST CENTURY MEDIA NEWSPAPER LLC	ADVERTISEMENT	90000	1215	262.25
05/29/2024	POOL	667033*#	DEARBORN NATIONAL LIFE INSURANCE	LIFE AND AD&D PREMIUM	71900	1215	159.84
				DISABILITY PREMIUM	71900	1215	230.19
				LONG TERM DISABILITY PREMIUM	71900	1215	64.21
				CHECK POOL 667033 TOTAL FOR FUND 101:			<u>454.24</u>
05/29/2024	POOL	667038	OFFICE EQUIPMENT RESOURCES INC	OFFICE SUPPLIES/REPAIR	80100	1215	118.00
				Total for department 1215:			1,352.94
Department: 1220 HUMAN RESOURCES							
05/29/2024	POOL	666914#	GEMINI FORMS & SYSTEMS	OFFICE SUPPLY	72700	1220	749.50
05/29/2024	POOL	666986*#	APPLIED INNOVATION	COPIER MAINTENANCE	80100	1220	58.33
05/29/2024	POOL	667033*#	DEARBORN NATIONAL LIFE INSURANCE	LIFE AND AD&D PREMIUM	71900	1220	131.42
				DISABILITY PREMIUM	71900	1220	245.74
				LONG TERM DISABILITY PREMIUM	71900	1220	68.53
				CHECK POOL 667033 TOTAL FOR FUND 101:			<u>445.69</u>
05/29/2024	POOL	667082*#	ASCENTIS CORPORATION	TIME CLOCK FEES	80100	1220	1,271.00
05/29/2024	POOL	667144	JUDITH M MALINOWSKI	MEDICAL SERVICES	82800	1220	1,000.00
				Total for department 1220:			3,524.52
Department: 1223 CONTROLLER							
05/09/2024	POOL	666786*#	DENCAP	DENTAL PREMIUMS	71900	1223	114.00

Check Date	Bank	Check #	Payee	Description	Account	Dept	Amount
Fund: 101 GENERAL FUND							
Department: 1223 CONTROLLER							
05/29/2024	POOL	667033*#	DEARBORN NATIONAL LIFE INSURANCE	LIFE AND AD&D PREMIUM	71900	1223	313.46
				DISABILITY PREMIUM	71900	1223	656.78
				LONG TERM DISABILITY PREMIUM	71900	1223	147.22
				CHECK POOL 667033 TOTAL FOR FUND 101:			<u>1,117.46</u>
05/29/2024	POOL	667098*#	ODP BUSINESS SOLUTIONS LLC	OFFICE SUPPLY	72700	1223	104.23
05/29/2024	POOL	667122	AMAZON CAPITAL SERVICES INC	OFFICE SUPPLY	72700	1223	304.99
				OFFICE SUPPLY	72700	1223	13.95
				CHECK POOL 667122 TOTAL FOR FUND 101:			<u>318.94</u>
				Total for department 1223:			1,654.63
Department: 1237 CITY RETIREMENT							
05/09/2024	POOL	666781*#	WINDSTREAM COMMUNICATIONS INC	TELEPHONE SERVICE	85300	1237	13.11
				TELEPHONE SERVICE	85300	1237	34.68
				CHECK POOL 666781 TOTAL FOR FUND 101:			<u>47.79</u>
05/29/2024	POOL	667033*#	DEARBORN NATIONAL LIFE INSURANCE	LIFE AND AD&D PREMIUM	71900	1237	50.02
				DISABILITY PREMIUM	71900	1237	93.08
				LONG TERM DISABILITY PREMIUM	71900	1237	25.96
				LIFE AND AD&D PREMIUM	71902	1237	597.26
				LIFE AND AD&D PREMIUM	71902	1237	143.80
				CHECK POOL 667033 TOTAL FOR FUND 101:			<u>910.12</u>
05/29/2024	POOL	667179	DENCAP	DENTAL PREMIUMS	71902	1237	1,174.20
				DENTAL PREMIUMS	71902	1237	309.00
				CHECK POOL 667179 TOTAL FOR FUND 101:			<u>1,483.20</u>
05/29/2024	POOL	667180#	DELTA DENTAL OF MICHIGAN	RETIREEES DENTAL INSURANCE	71902	1237	2,384.28
				RETIREEES DENTAL INSURANCE	71902	1237	7,098.84
				CHECK POOL 667180 TOTAL FOR FUND 101:			<u>9,483.12</u>
				Total for department 1237:			11,924.23
Department: 1238 POLICE & FIRE RETIREMENT							
05/09/2024	POOL	666781*#	WINDSTREAM COMMUNICATIONS INC	TELEPHONE SERVICE	85300	1238	9.83

05/22/2024 11:26 AM
 User: tcameron
 DB: Warren

CHECK DISBURSEMENT REPORT FOR CITY OF WARREN
 CHECK NUMBER 666777 - 667227

Check Date	Bank	Check #	Payee	Description	Account	Dept	Amount
Fund: 101 GENERAL FUND							
Department: 1238 POLICE & FIRE RETIREMENT							
				TELEPHONE SERVICE	85300	1238	26.01
				CHECK POOL 666781 TOTAL FOR FUND 101:			<u>35.84</u>
05/29/2024	POOL	667033*#	DEARBORN NATIONAL LIFE INSURANCE	LIFE AND AD&D PREMIUM	71900	1238	72.82
				DISABILITY PREMIUM	71900	1238	135.77
				LONG TERM DISABILITY PREMIUM	71900	1238	37.87
				LIFE AND AD&D PREMIUM	71902	1238	503.42
				CHECK POOL 667033 TOTAL FOR FUND 101:			<u>749.88</u>
05/29/2024	POOL	667181#	DELTA DENTAL OF MICHIGAN	P&F RETIREES DENTAL	71902	1238	1,475.56
				P&F RETIREES DENTAL	71902	1238	38.13
				P&F RETIREES DENTAL	71902	1238	2,492.21
				P&F RETIREES DENTAL	71902	1238	168.10
				P&F RETIREES DENTAL	71902	1238	11,360.81
				CHECK POOL 667181 TOTAL FOR FUND 101:			<u>15,534.81</u>
				Total for department 1238:			16,320.53
Department: 1253 TREASURER							
05/09/2024	POOL	666783*#	POINT & PAY	FEB24 PROCESSING FEES	80100	1253	613.50
05/29/2024	POOL	666914#	GEMINI FORMS & SYSTEMS	OFFICE SUPPLY	72700	1253	786.88
05/29/2024	POOL	666982*#	GREAT LAKES GRAPHICS INC	PRINTING SERVICE	83600	1253	169.57
				PRINTING SERVICE	83600	1253	75.00
				CHECK POOL 666982 TOTAL FOR FUND 101:			<u>244.57</u>
05/29/2024	POOL	667033*#	DEARBORN NATIONAL LIFE INSURANCE	LIFE AND AD&D PREMIUM	71900	1253	188.85
				DISABILITY PREMIUM	71900	1253	283.49
				LONG TERM DISABILITY PREMIUM	71900	1253	65.16
				CHECK POOL 667033 TOTAL FOR FUND 101:			<u>537.50</u>
				Total for department 1253:			2,182.45
Department: 1258 INFORMATION SYSTEMS							
05/29/2024	POOL	666913*#	GOV CONNECTION INC	HARDWARE	74000	1258	311.25
				HARDWARE	74000	1258	2,245.76
				HARDWARE	74000	1258	1,122.88
				COMPUTER EQUIPMENT	74000	1258	717.72

05/22/2024 11:26 AM
 User: tcameron
 DB: Warren

CHECK DISBURSEMENT REPORT FOR CITY OF WARREN
 CHECK NUMBER 666777 - 667227

Check Date	Bank	Check #	Payee	Description	Account	Dept	Amount
Fund: 101 GENERAL FUND							
Department: 1258 INFORMATION SYSTEMS							
				COMPUTER EQUIPMENT	74000	1258	271.53
				CHECK POOL 666913 TOTAL FOR FUND 101:			<u>4,669.14</u>
05/29/2024	POOL	666938	ZOHO CORPORATION	SOFTWARE SUBSCRIPTION	80100	1258	540.00
				SOFTWARE SUBSCRIPTION	80100	1258	22.13
				CHECK POOL 666938 TOTAL FOR FUND 101:			<u>562.13</u>
05/29/2024	POOL	667033*#	DEARBORN NATIONAL LIFE INSURANCE	LIFE AND AD&D PREMIUM	71900	1258	109.82
				DISABILITY PREMIUM	71900	1258	204.77
				LONG TERM DISABILITY PREMIUM	71900	1258	57.12
				CHECK POOL 667033 TOTAL FOR FUND 101:			<u>371.71</u>
05/29/2024	POOL	667098*#	ODP BUSINESS SOLUTIONS LLC	OFFICE SUPPLY	74000	1258	268.14
				OFFICE SUPPLY	74000	1258	104.19
				OFFICE SUPPLY	74000	1258	42.99
				OFFICE SUPPLY	74000	1258	51.95
				OFFICE SUPPLY	74000	1258	31.87
				CHECK POOL 667098 TOTAL FOR FUND 101:			<u>499.14</u>
05/29/2024	POOL	667138	ADVANCED IT PROFESSIONALS LLC	CONTRACTUAL SERVICES	80100	1258	150.00
				Total for department 1258:			<u>6,252.12</u>
Department: 1265 BUILDING MAINTENANCE							
05/09/2024	POOL	666786*#	DENCAP	DENTAL PREMIUMS	71900	1265	171.00
05/29/2024	POOL	666813	DETROIT CHEMICAL & PAPER	BUILDING MAINTENANCE	77600	1265	2,250.35
05/29/2024	POOL	666821*#	GRAINGER INC	JANITORIAL SUPPLY	74000	1265	230.60
				JANITORIAL SUPPLY	74000	1265	525.00
				CHECK POOL 666821 TOTAL FOR FUND 101:			<u>755.60</u>
05/29/2024	POOL	666829	PATRICK PHOTOGRAPHIC STUDIOS	PHOTOGRAPHY/FRAMES	80110	1265	3,367.00
05/29/2024	POOL	666854#	ROCKET ENTERPRISE INC	FLAGS	77600	1265	15.00
				FLAGS	77600	1265	1,064.00
				CHECK POOL 666854 TOTAL FOR FUND 101:			<u>1,079.00</u>
05/29/2024	POOL	666866*#	SCHEMA ROOFING & SHEET	HVAC ROOF REPAIR	77600	1265	2,315.00

Check Date	Bank	Check #	Payee	Description	Account	Dept	Amount
Fund: 101 GENERAL FUND							
Department: 1265 BUILDING MAINTENANCE							
05/29/2024	POOL	666903#	GREAT LAKES SECURITY HARDWARE	KEYS/CITY HALL	74000	1265	17.16
05/29/2024	POOL	666918	CINTAS FIRST AID & SAFETY	FIRST AID SUPPLY	74000	1265	205.38
05/29/2024	POOL	666919*#	CINTAS FIRST AID & SAFETY	FIRST AID SUPPLY	74000	1265	109.59
				FIRST AID SUPPLY	74000	1265	87.61
				CHECK POOL 666919 TOTAL FOR FUND 101:			<u>197.20</u>
05/29/2024	POOL	666952#	IGNITED LIGHT AND SOUND	LIGHTING UP OF CITY HALL	74000	1265	450.00
05/29/2024	POOL	667033*#	DEARBORN NATIONAL LIFE INSURANCE	LIFE AND AD&D PREMIUM	71900	1265	264.62
				DISABILITY PREMIUM	71900	1265	494.47
				LONG TERM DISABILITY PREMIUM	71900	1265	120.87
				CHECK POOL 667033 TOTAL FOR FUND 101:			<u>879.96</u>
05/29/2024	POOL	667054*#	AMERICAN PEST CONTROL INC	PEST CONTROL SERVICES	80110	1265	60.00
				PEST CONTROL SERVICES	80110	1265	10.00
				PEST CONTROL SERVICES	80110	1265	28.00
				CHECK POOL 667054 TOTAL FOR FUND 101:			<u>98.00</u>
05/29/2024	POOL	667086	SUPREME SWEEPING SERVICES INC	SWEEPING	80110	1265	450.00
				Total for department 1265:			12,235.65
Department: 1294 ADMIN UNALLOCATED EXPENSE							
05/09/2024	POOL	666778*#	DTE ENERGY	ELECTRIC SERVICE	92002	1294	68.10
05/09/2024	POOL	666781*#	WINDSTREAM COMMUNICATIONS INC	TELEPHONE SERVICE	85300	1294	583.30
				TELEPHONE SERVICE	85300	1294	1,543.10
				TELEPHONE SERVICE	85300	1294	238.79
				CHECK POOL 666781 TOTAL FOR FUND 101:			<u>2,365.19</u>
05/09/2024	POOL	666782	WOW! BUSINESS	INTERNET SERVICE	92002	1294	1,320.99
05/16/2024	POOL	666792*#	VERIZON WIRELESS	CELLULAR SERVICE	85300	1294	41.05
05/29/2024	POOL	666835*#	CITY OF WARREN	WATER SERVICE	92001	1294	41.93
				WATER SERVICE	92001	1294	2.72

Check Date	Bank	Check #	Payee	Description	Account	Dept	Amount
Fund: 101 GENERAL FUND							
Department: 1294 ADMIN UNALLOCATED EXPENSE							
				WATER SERVICE	92002	1294	10.74
				WATER SERVICE	92002	1294	3.37
				WATER SERVICE	92002	1294	708.82
				CHECK POOL 666835 TOTAL FOR FUND 101:			<u>767.58</u>
05/29/2024	POOL	666848	RONALD WUERTH	TRAVEL EXPENSE	86400	1294	165.00
05/29/2024	POOL	666934	MICHELLE KATOPODES	TRAVEL EXPENSE	86400	1294	176.25
05/29/2024	POOL	666960	KIRK REHN	TRAVEL EXPENSE	86400	1294	48.68
05/29/2024	POOL	667005	DAVID BEAN	TRAVEL EXPENSE	86400	1294	79.72
05/29/2024	POOL	667006#	MICHAEL FONTANA	REIMBURSEMENT	86400	1294	250.00
05/29/2024	POOL	667027#	THE ASU GROUP	LOSS FUND REIMBURSEMENT	91000	1294	240,752.09
05/29/2024	POOL	667030	THE ASU GROUP (SERVICE FEES)	CLAIMS SERVICE FEES	91000	1294	5,680.00
05/29/2024	POOL	667050	SULTANA CHOWDHURY	REIMBURSEMENT	86400	1294	250.00
05/29/2024	POOL	667062	PAUL RETASKIE	TRAVEL EXPENSE	86400	1294	103.52
05/29/2024	POOL	667094	ADAM DUFF	TRAVEL EXPENSE	86400	1294	89.66
				Total for department 1294:			252,157.83
Department: 1301 POLICE DEPARTMENT							
05/09/2024	POOL	666778*#	DTE ENERGY	ELECTRIC SERVICE	92000	1301	133.79
05/09/2024	POOL	666781*#	WINDSTREAM COMMUNICATIONS INC	TELEPHONE SERVICE	85300	1301	399.52
05/09/2024	POOL	666785	LOADOMETER CORPORATION	EQUIPMENT	98402	1301	10,590.00
05/09/2024	POOL	666786*#	DENCAP	DENTAL PREMIUMS	71900	1301	912.00
05/16/2024	POOL	666793	BERGER CHEVROLET INC	VEHICLE	98402	1301	51,522.00
05/29/2024	POOL	666810*#	C & G PUBLISHING INC	ADVERTISEMENT	74000	1301	136.00
05/29/2024	POOL	666821*#	GRAINGER INC	BUILDING MAINTENANCE	93000	1301	630.03
05/29/2024	POOL	666822	GROESBECK GLAZING	BUILDING MAINTENANCE	93000	1301	360.00
05/29/2024	POOL	666835*#	CITY OF WARREN	WATER SERVICE	92000	1301	21.11

Check Date	Bank	Check #	Payee	Description	Account	Dept	Amount
Fund: 101 GENERAL FUND							
Department: 1301 POLICE DEPARTMENT							
				WATER SERVICE	92000	1301	6.63
				WATER SERVICE	92000	1301	1,006.59
				WATER SERVICE	92000	1301	21.57
				CHECK POOL 666835 TOTAL FOR FUND 101:			<u>1,055.90</u>
05/29/2024	POOL	666847	EMEDCO	OPERATING SUPPLY	88012	1301	514.77
				OPERATING SUPPLY	88012	1301	764.37
				OPERATING SUPPLY	88012	1301	67.60
				CHECK POOL 666847 TOTAL FOR FUND 101:			<u>1,346.74</u>
05/29/2024	POOL	666857	MICHIGAN ASSOC OF CHIEFS OF POLICE	TRAINING	82401	1301	100.00
				TRAINING	82401	1301	100.00
				TRAINING	82401	1301	100.00
				TRAINING	82401	1301	115.00
				CHECK POOL 666857 TOTAL FOR FUND 101:			<u>415.00</u>
05/29/2024	POOL	666860	JOHN E REID & ASSOCIATES	TRAINING	82401	1301	580.00
05/29/2024	POOL	666891*#	B & H PHOTO - VIDEO INC	OFFICE SUPPLY	72700	1301	162.42
				OFFICE SUPPLY	72700	1301	44.97
				CHECK POOL 666891 TOTAL FOR FUND 101:			<u>207.39</u>
05/29/2024	POOL	666903#	GREAT LAKES SECURITY HARDWARE	BUILDING MAINTENANCE	93000	1301	19.00
05/29/2024	POOL	666959	MICHIGAN STATE POLICE	REGISTRATION FEES	80100	1301	570.00
05/29/2024	POOL	666963	NORTHWESTERN UNIVERSITY	TRAINING	82401	1301	4,600.00
				TRAINING	82401	1301	4,600.00
				CHECK POOL 666963 TOTAL FOR FUND 101:			<u>9,200.00</u>
05/29/2024	POOL	666981	PRIORITY DISPATCH CORP	TRAINING	82402	1301	425.00
05/29/2024	POOL	666986*#	APPLIED INNOVATION	COPIER MAINTENANCE	80100	1301	35.76
				COPIER MAINTENANCE	80100	1301	68.88
				COPIER MAINTENANCE	80100	1301	47.20
				COPIER MAINTENANCE	80100	1301	76.02
				COPIER MAINTENANCE	80100	1301	106.09
				CHECK POOL 666986 TOTAL FOR FUND 101:			<u>333.95</u>

Check Date	Bank	Check #	Payee	Description	Account	Dept	Amount
Fund: 101 GENERAL FUND							
Department: 1301 POLICE DEPARTMENT							
05/29/2024	POOL	667019	WOODWARD CAMERA	EQUIPMENT MAINTENANCE	80100	1301	249.00
05/29/2024	POOL	667033*#	DEARBORN NATIONAL LIFE INSURANCE	LIFE AND AD&D PREMIUM	71900	1301	4,472.86
				DISABILITY PREMIUM	71900	1301	12,037.04
				LONG TERM DISABILITY PREMIUM	71900	1301	289.72
				CHECK POOL 667033 TOTAL FOR FUND 101:			<u>16,799.62</u>
05/29/2024	POOL	667054*#	AMERICAN PEST CONTROL INC	PEST CONTROL SERVICES	80100	1301	28.00
05/29/2024	POOL	667093	THREE PALM TEE'S	PROMOTIONAL SUPPLY	88003	1301	66.00
				PROMOTIONAL SUPPLY	88003	1301	66.00
				PROMOTIONAL SUPPLY	88003	1301	95.00
				PROMOTIONAL SUPPLY	88003	1301	95.00
				PROMOTIONAL SUPPLY	88003	1301	126.00
				PROMOTIONAL SUPPLY	88003	1301	126.00
				CHECK POOL 667093 TOTAL FOR FUND 101:			<u>574.00</u>
05/29/2024	POOL	667098*#	ODP BUSINESS SOLUTIONS LLC	OFFICE SUPPLY	72700	1301	5.02
				OFFICE SUPPLY	72700	1301	1,732.20
				OFFICE SUPPLY	72700	1301	239.44
				OFFICE SUPPLY	72700	1301	576.98
				OFFICE SUPPLY	72700	1301	185.68
				OFFICE SUPPLY	72700	1301	678.66
				CHECK POOL 667098 TOTAL FOR FUND 101:			<u>3,417.98</u>
05/29/2024	POOL	667106	SETCOM	RADIO SUPPLY	85300	1301	20.00
				RADIO SUPPLY	85300	1301	20.00
				RADIO SUPPLY	85300	1301	20.00
				CHECK POOL 667106 TOTAL FOR FUND 101:			<u>60.00</u>
05/29/2024	POOL	667110#	VARIETY FOODSERVICES INC	PRISONER FOOD	81200	1301	1,059.84
				PRISONER FOOD	81200	1301	1,059.84
				CHECK POOL 667110 TOTAL FOR FUND 101:			<u>2,119.68</u>
05/29/2024	POOL	667225*#	USA PLUMBING	PLUMBING SERVICE	93000	1301	131.00
				PLUMBING SERVICE	93000	1301	421.85
				CHECK POOL 667225 TOTAL FOR FUND 101:			<u>552.85</u>

05/22/2024 11:26 AM
User: tcameron
DB: Warren

CHECK DISBURSEMENT REPORT FOR CITY OF WARREN
CHECK NUMBER 666777 - 667227

Check Date	Bank	Check #	Payee	Description	Account	Dept	Amount
Fund: 101 GENERAL FUND							
Department: 1301 POLICE DEPARTMENT							
Total for department 1301:							102,637.45
Department: 1311 CRIME COMMISSION							
05/16/2024	POOL	666788*#	DTE ENERGY	ELECTRIC SERVICE	92000	1311	35.30
05/29/2024	POOL	666835*#	CITY OF WARREN	WATER SERVICE	92000	1311	10.78
05/29/2024	POOL	666978	4 IMPRINT INC	PROMOTIONAL SUPPLY	88001	1311	409.06
05/29/2024	POOL	666980	BOBS SPECIALTY COMPANY	PROMOTIONAL ITEMS	88001	1311	518.00
				PROMOTIONAL ITEMS	88001	1311	436.00
				PROMOTIONAL ITEMS	88001	1311	563.82
				PROMOTIONAL ITEMS	88001	1311	645.00
				PROMOTIONAL ITEMS	88001	1311	465.00
				PROMOTIONAL ITEMS	88001	1311	370.00
				PROMOTIONAL ITEMS	88001	1311	764.86
				PROMOTIONAL ITEMS	88001	1311	461.89
CHECK POOL 666980 TOTAL FOR FUND 101:							4,224.57
Total for department 1311:							4,679.71
Department: 1336 FIRE DEPARTMENT							
05/09/2024	POOL	666780	VERIZON WIRELESS	CELLULAR SERVICE	85300	1336	200.48
05/09/2024	POOL	666781*#	WINDSTREAM COMMUNICATIONS INC	TELEPHONE SERVICE	85300	1336	174.04
				TELEPHONE SERVICE	85300	1336	248.28
				TELEPHONE SERVICE	85300	1336	167.89
				TELEPHONE SERVICE	85300	1336	207.00
				TELEPHONE SERVICE	85300	1336	210.78
				TELEPHONE SERVICE	85300	1336	210.78
CHECK POOL 666781 TOTAL FOR FUND 101:							1,218.77
05/09/2024	POOL	666786*#	DENCAP	DENTAL PREMIUMS	71900	1336	627.00
05/16/2024	POOL	666788*#	DTE ENERGY	ELECTRIC SERVICE	92000	1336	780.71
				ELECTRIC SERVICE	92000	1336	967.52
CHECK POOL 666788 TOTAL FOR FUND 101:							1,748.23
05/16/2024	POOL	666791#	AT&T MOBILITY	MOBILE DEVICES/PLANS-FIRE DEPARTMENT	85300	1336	1,461.01

Check Date	Bank	Check #	Payee	Description	Account	Dept	Amount
Fund: 101 GENERAL FUND							
Department: 1336 FIRE DEPARTMENT							
05/16/2024	POOL	666792*#	VERIZON WIRELESS	CELLULAR SERVICE	85300	1336	1,258.56
05/16/2024	POOL	666794	TODD WENZEL BUICK GMC	FIRE DEPARTMENT VEHICLES	97400	1336	50,117.95
05/29/2024	POOL	666821*#	GRAINGER INC	OPERATING SUPPLY	74000	1336	356.91
				OPERATING SUPPLY	74000	1336	50.56
				OPERATING SUPPLY	74000	1336	128.26
				OPERATING SUPPLY	74000	1336	38.76
				OPERATING SUPPLY	74000	1336	23.42
				OPERATING SUPPLY	74000	1336	252.18
				OPERATING SUPPLY	74000	1336	146.18
				OPERATING SUPPLY	74000	1336	132.78
				CREDIT MEMO	74000	1336	(16.74)
				CHECK POOL 666821 TOTAL FOR FUND 101:			<u>1,112.31</u>
05/29/2024	POOL	666830	QUICK MADE TROPHY SALES	ENGRAVING SERVICES	74000	1336	20.00
05/29/2024	POOL	666833#	STATE CHEMICAL SOLUTIONS	JANITORIAL SUPPLY	74000	1336	307.30
				JANITORIAL SUPPLY	74000	1336	376.44
				CHECK POOL 666833 TOTAL FOR FUND 101:			<u>683.74</u>
05/29/2024	POOL	666835*#	CITY OF WARREN	WATER SERVICE	92000	1336	353.65
				WATER SERVICE	92000	1336	268.17
				WATER SERVICE	92000	1336	21.57
				WATER SERVICE	92000	1336	30.18
				WATER SERVICE	92000	1336	212.06
				WATER SERVICE	92000	1336	408.48
				WATER SERVICE	92000	1336	21.57
				WATER SERVICE	92000	1336	258.82
				WATER SERVICE	92000	1336	249.47
				CHECK POOL 666835 TOTAL FOR FUND 101:			<u>1,823.97</u>
05/29/2024	POOL	666853	MICHIGAN STATE FIREMEN'S	TRAINING MATERIALS	82401	1336	561.24
				TRAINING MATERIALS	82401	1336	11.23
				CHECK POOL 666853 TOTAL FOR FUND 101:			<u>572.47</u>
05/29/2024	POOL	666854#	ROCKET ENTERPRISE INC	OPERATING SUPPLY	74000	1336	55.00
05/29/2024	POOL	666866*#	SCHEMA ROOFING & SHEET	ROOF REPLACEMENT	97400	1336	51,760.00

05/22/2024 11:26 AM
 User: tcameron
 DB: Warren

CHECK DISBURSEMENT REPORT FOR CITY OF WARREN
 CHECK NUMBER 666777 - 667227

Check Date	Bank	Check #	Payee	Description	Account	Dept	Amount
Fund: 101 GENERAL FUND							
Department: 1336 FIRE DEPARTMENT							
05/29/2024	POOL	666870	MELISSA HOPKINS	REIMBURSEMENT	74000	1336	427.75
05/29/2024	POOL	666891*#	B & H PHOTO - VIDEO INC	TRAINING ROOM SUPPLIES	74000	1336	1,049.95
				TRAINING ROOM SUPPLIES	74000	1336	259.99
				CHECK POOL 666891 TOTAL FOR FUND 101:			<u>1,309.94</u>
05/29/2024	POOL	666892	PRESSURE VESSEL TESTING	OPERATING SUPPLY	74000	1336	495.00
				OPERATING SUPPLY	74000	1336	303.00
				CHECK POOL 666892 TOTAL FOR FUND 101:			<u>798.00</u>
05/29/2024	POOL	666904	UNITED PARCEL SERVICE	SHIPPING SERVICE	74000	1336	27.98
05/29/2024	POOL	666910*#	BOUND TREE MEDICAL	MEDICAL SUPPLY	72701	1336	1,537.77
				MEDICAL SUPPLY	72701	1336	1,784.53
				MEDICAL SUPPLY	72701	1336	883.20
				MEDICAL SUPPLY	72701	1336	134.90
				CHECK POOL 666910 TOTAL FOR FUND 101:			<u>4,340.40</u>
05/29/2024	POOL	666926	IDENTISYS INCORPORATED	PRINTER SUPPLIES	74000	1336	128.77
05/29/2024	POOL	666939	STATE OF MICHIGAN	QUARTERLY AMBULANCE TAX	72701	1336	10,071.22
05/29/2024	POOL	666946*#	LANDSCAPE SERVICE INC	MOWING/FERTILIZATION	80100	1336	780.00
05/29/2024	POOL	666948	ALERT ALL CORP	FIRE PREVENTION MATERIALS	80101	1336	1,200.00
				FIRE PREVENTION MATERIALS	80101	1336	480.00
				FIRE PREVENTION MATERIALS	80101	1336	480.00
				FIRE PREVENTION MATERIALS	80101	1336	322.50
				FIRE PREVENTION MATERIALS	80101	1336	1,950.00
				CHECK POOL 666948 TOTAL FOR FUND 101:			<u>4,432.50</u>
05/29/2024	POOL	666952#	IGNITED LIGHT AND SOUND	AUDIO/ LIGHTING SYSTEM-CADET CEREMONY	74000	1336	450.00
05/29/2024	POOL	666953	CYNERGY WIRELESS PRODUCTS	REPLACEMENT PARTS/RADIOS	85300	1336	35.00
05/29/2024	POOL	666961	APPLE INC	COMPUTER EQUIPMENT	74000	1336	158.00
				COMPUTER EQUIPMENT	74000	1336	1,399.00
				COMPUTER EQUIPMENT	74000	1336	1,727.00
				CHECK POOL 666961 TOTAL FOR FUND 101:			<u>3,284.00</u>

Check Date	Bank	Check #	Payee	Description	Account	Dept	Amount
Fund: 101 GENERAL FUND							
Department: 1336 FIRE DEPARTMENT							
CHECK POOL 667054 TOTAL FOR FUND 101:							201.00
05/29/2024	POOL	667056	TARGET SOLUTIONS LEARNING LLC	MANAGEMENT SYSTEM SOFTWARE	80100	1336	38,627.98
05/29/2024	POOL	667063	HENRY FORD MACOMB HOSP	EMS CERTIFICATIONS	82401	1336	151.05
05/29/2024	POOL	667087	JAKAB BONNER	TRAVEL EXPENSE	82401	1336	795.28
05/29/2024	POOL	667098*#	ODP BUSINESS SOLUTIONS LLC	OFFICE SUPPLY	74000	1336	170.78
				OFFICE SUPPLY	74000	1336	35.03
				OFFICE SUPPLY	74000	1336	391.40
				OFFICE SUPPLY	74000	1336	182.72
				OFFICE SUPPLY	74000	1336	68.38
				OFFICE SUPPLY	74000	1336	322.44
				OFFICE SUPPLY	74000	1336	14.49
				OFFICE SUPPLY	74000	1336	20.29
				OFFICE SUPPLY	74000	1336	42.31
				OFFICE SUPPLY	74000	1336	19.00
				OFFICE SUPPLY	74000	1336	171.38
				OFFICE SUPPLY	74000	1336	161.50
				OFFICE SUPPLY	74000	1336	114.95
				OFFICE SUPPLY	74000	1336	26.54
				OFFICE SUPPLY	74000	1336	38.95
CHECK POOL 667098 TOTAL FOR FUND 101:							1,780.16
05/29/2024	POOL	667099	CYLER SCHREINER	REIMBURSEMENT	74000	1336	77.75
05/29/2024	POOL	667112	BMW KAR WASH LLC	CAR WASH	80100	1336	118.75
05/29/2024	POOL	667139	DONALD K ROSS	NEW RECRUITS CEREMONY SOLO PIPING	74000	1336	200.00
05/29/2024	POOL	667153	PI-LIT TECHNOLOGIES	EMERGENCY STROBE LIGHTS	74000	1336	1,488.00
				EMERGENCY STROBE LIGHTS	74000	1336	35.00
CHECK POOL 667153 TOTAL FOR FUND 101:							1,523.00
05/29/2024	POOL	667173	RICHARD MORROW	REIMBURSEMENT	74000	1336	25.00
05/29/2024	POOL	667221#	GARRETT DOOR CO	OVERHEAD DOOR MAINTENANCE	93000	1336	4,995.00
				OVERHEAD DOOR MAINTENANCE	93000	1336	155.00
				OVERHEAD DOOR MAINTENANCE	93000	1336	655.00
				OVERHEAD DOOR MAINTENANCE	93000	1336	127.50
				OVERHEAD DOOR MAINTENANCE	93000	1336	75.00
				OVERHEAD DOOR MAINTENANCE	93000	1336	2,180.00

Check Date	Bank	Check #	Payee	Description	Account	Dept	Amount
Fund: 101 GENERAL FUND							
Department: 1336 FIRE DEPARTMENT							
				CHECK POOL 667221 TOTAL FOR FUND 101:			8,187.50
05/29/2024	POOL	667225*#	USA PLUMBING	PLUMBING SERVICE	93000	1336	345.00
				PLUMBING SERVICE	93000	1336	307.65
				CHECK POOL 667225 TOTAL FOR FUND 101:			652.65
				Total for department 1336:			222,688.16
Department: 1371 BUILDING INSPECTIONS							
05/09/2024	POOL	666783*#	POINT & PAY	FEB24 PROCESSING FEES	80100	1371	31.75
05/09/2024	POOL	666786*#	DENCAP	DENTAL PREMIUMS	71900	1371	57.00
05/16/2024	POOL	666792*#	VERIZON WIRELESS	CELLULAR SERVICE	85300	1371	100.47
05/29/2024	POOL	666894	COLONIAL TITLE	TITLE SEARCHES	80141	1371	85.00
				TITLE SEARCHES	80141	1371	85.00
				TITLE SEARCHES	80141	1371	85.00
				CHECK POOL 666894 TOTAL FOR FUND 101:			255.00
05/29/2024	POOL	667033*#	DEARBORN NATIONAL LIFE INSURANCE	LIFE AND AD&D PREMIUM	71900	1371	501.72
				DISABILITY PREMIUM	71900	1371	933.71
				LONG TERM DISABILITY PREMIUM	71900	1371	260.36
				CHECK POOL 667033 TOTAL FOR FUND 101:			1,695.79
05/29/2024	POOL	667098*#	ODP BUSINESS SOLUTIONS LLC	OFFICE SUPPLY	72700	1371	254.96
				OFFICE SUPPLY	72700	1371	256.62
				OFFICE SUPPLY	72700	1371	76.20
				OFFICE SUPPLY	72700	1371	23.99
				CHECK POOL 667098 TOTAL FOR FUND 101:			611.77
05/29/2024	POOL	667113*#	BMW KAR WASH LLC	CAR WASH	86300	1371	99.75
05/29/2024	POOL	667171	COURTNEY RAJTER	REIMBURSEMENT	72501	1371	50.17
05/29/2024	POOL	667172	MICHAEL SWAFFORD	CONTRACTUAL SERVICES	80100	1371	1,170.00
				Total for department 1371:			4,071.70
Department: 1400 PLANNING							

Check Date	Bank	Check #	Payee	Description	Account	Dept	Amount
Fund: 101 GENERAL FUND							
Department: 1400 PLANNING							
05/09/2024	POOL	666786*#	DENCAP	DENTAL PREMIUMS	71900	1400	57.00
05/29/2024	POOL	666986*#	APPLIED INNOVATION	COPIER MAINTENANCE	72700	1400	153.70
05/29/2024	POOL	667033*#	DEARBORN NATIONAL LIFE INSURANCE	LIFE AND AD&D PREMIUM	71900	1400	151.55
				DISABILITY PREMIUM	71900	1400	282.97
				LONG TERM DISABILITY PREMIUM	71900	1400	78.92
				CHECK POOL 667033 TOTAL FOR FUND 101:			<u>513.44</u>
05/29/2024	POOL	667042	MARCO TECHNOLOGIES LLC	PLOTTER TONER/PAPER	72700	1400	178.27
05/29/2024	POOL	667098*#	ODP BUSINESS SOLUTIONS LLC	OFFICE SUPPLY	72700	1400	35.37
				OFFICE SUPPLY	72700	1400	19.99
				CHECK POOL 667098 TOTAL FOR FUND 101:			<u>55.36</u>
				Total for department 1400:			957.77
Department: 1401 COMMUNITY & ECONOMIC DEVE							
05/29/2024	POOL	667033*#	DEARBORN NATIONAL LIFE INSURANCE	LIFE AND AD&D PREMIUM	71900	1401	37.89
				DISABILITY PREMIUM	71900	1401	70.90
				LONG TERM DISABILITY PREMIUM	71900	1401	11.77
				CHECK POOL 667033 TOTAL FOR FUND 101:			<u>120.56</u>
				Total for department 1401:			120.56
Department: 1410 ZONING BOARD OF APPEALS							
05/29/2024	POOL	666968	ROMAN T NESTOROWICZ	BOARD OF APPEALS	72500	1410	75.00
05/29/2024	POOL	667014	CHARLES ANGLIN	BOARD OF APPEALS	72500	1410	75.00
05/29/2024	POOL	667036	MICHAEL SYLVESTER	BOARD OF APPEALS	72500	1410	75.00
05/29/2024	POOL	667064	PAUL JERZY	BOARD OF APPEALS	72500	1410	75.00
05/29/2024	POOL	667065	ANTHONY T SIERACKI JR	BOARD OF APPEALS	72500	1410	75.00
05/29/2024	POOL	667066	CHARLES L PERRY	BOARD OF APPEALS	72500	1410	75.00
05/29/2024	POOL	667100	DAVID A SOPHIEA	BOARD OF APPEALS	72500	1410	75.00
				Total for department 1410:			525.00
Department: 1421 PUBLIC SERVICES DIRECTOR							
05/16/2024	POOL	666792*#	VERIZON WIRELESS	CELLULAR SERVICE	85300	1421	72.02

Check Date	Bank	Check #	Payee	Description	Account	Dept	Amount
Fund: 101 GENERAL FUND							
Department: 1421 PUBLIC SERVICES DIRECTOR							
05/29/2024	POOL	667033*#	DEARBORN NATIONAL LIFE INSURANCE	LIFE AND AD&D PREMIUM	71900	1421	81.99
				DISABILITY PREMIUM	71900	1421	153.25
				LONG TERM DISABILITY PREMIUM	71900	1421	42.73
				CHECK POOL 667033 TOTAL FOR FUND 101:			<u>277.97</u>
				Total for department 1421:			349.99
Department: 1422 PROPERTY MAINTENANCE							
05/09/2024	POOL	666786*#	DENCAP	DENTAL PREMIUMS	71900	1422	114.00
05/16/2024	POOL	666792*#	VERIZON WIRELESS	CELLULAR SERVICE	85300	1422	307.28
05/29/2024	POOL	666835*#	CITY OF WARREN	WATER SERVICE	92000	1422	12.08
				WATER SERVICE	92000	1422	66.11
				CHECK POOL 666835 TOTAL FOR FUND 101:			<u>78.19</u>
05/29/2024	POOL	666839#	WEST GROUP	CLEAR ONLINE SEARCH SERVICES	74000	1422	498.96
05/29/2024	POOL	666886*#	HOME DEPOT CREDIT SERVICE	BLIGHT SUPPLIES	74000	1422	137.94
05/29/2024	POOL	666907	COPY COPY CENTER	OFFICE SUPPLIES	90000	1422	449.00
05/29/2024	POOL	666943#	HELLEBUYCKS POWER EQUIP	MAINTENANCE SUPPLY	74000	1422	9.16
				MAINTENANCE SUPPLY	74000	1422	4.54
				CHECK POOL 666943 TOTAL FOR FUND 101:			<u>13.70</u>
05/29/2024	POOL	666946*#	LANDSCAPE SERVICE INC	RODENT BAITING SERVICE	80108	1422	840.00
				RODENT BAITING SERVICE	80108	1422	1,590.00
				RODENT BAITING SERVICE	80108	1422	2,594.00
				RODENT BAITING SERVICE	80108	1422	4,620.00
				RODENT BAITING SERVICE	80108	1422	2,130.00
				RODENT BAITING SERVICE	80108	1422	1,470.00
				CHECK POOL 666946 TOTAL FOR FUND 101:			<u>13,244.00</u>
05/29/2024	POOL	666986*#	APPLIED INNOVATION	COPIER MAINTENANCE	72700	1422	153.69
05/29/2024	POOL	667007*#	21ST CENTURY MEDIA NEWSPAPER LLC	NOXIOUS WEED AD	90000	1422	163.00

Check Date	Bank	Check #	Payee	Description	Account	Dept	Amount
Fund: 101 GENERAL FUND							
Department: 1422 PROPERTY MAINTENANCE							
05/29/2024	POOL	667033*#	DEARBORN NATIONAL LIFE INSURANCE	LIFE AND AD&D PREMIUM	71900	1422	115.14
				DISABILITY PREMIUM	71900	1422	215.04
				LONG TERM DISABILITY PREMIUM	71900	1422	59.98
				CHECK POOL 667033 TOTAL FOR FUND 101:			<u>390.16</u>
				Total for department 1422:			15,549.92
Department: 1426 CIVIL DEFENSE							
05/09/2024	POOL	666778*#	DTE ENERGY	ELECTRIC SERVICE	92000	1426	145.60
05/29/2024	POOL	667033*#	DEARBORN NATIONAL LIFE INSURANCE	LIFE AND AD&D PREMIUM	71900	1426	30.78
				DISABILITY PREMIUM	71900	1426	57.50
				CHECK POOL 667033 TOTAL FOR FUND 101:			<u>88.28</u>
				Total for department 1426:			233.88
Department: 1430 ANIMAL CONTROL							
05/09/2024	POOL	666786*#	DENCAP	DENTAL PREMIUMS	71900	1430	57.00
05/29/2024	POOL	666884*#	PSP STORES LLC	ANIMAL CONTROL SUPPLY	74000	1430	195.89
05/29/2024	POOL	667033*#	DEARBORN NATIONAL LIFE INSURANCE	LIFE AND AD&D PREMIUM	71900	1430	54.46
				DISABILITY PREMIUM	71900	1430	101.70
				LONG TERM DISABILITY PREMIUM	71900	1430	28.36
				CHECK POOL 667033 TOTAL FOR FUND 101:			<u>184.52</u>
05/29/2024	POOL	667059	I HEART DOGS RESCUE & ANIMAL HAVEN	ANIMAL SHELTER SERVICES	80500	1430	1,400.00
05/29/2024	POOL	667096	THE WASHTUB	LAUNDRY SERVICE	74000	1430	36.25
05/29/2024	POOL	667124	EASTPOINTE ANIMAL HOSPITAL	ANIMAL SERVICE	80500	1430	142.00
05/29/2024	POOL	667158	COUNTY OF LAPEER	ANIMAL DISPOSALS	80500	1430	300.00
				Total for department 1430:			2,315.66
Department: 1441 STREET MAINTENANCE DIV							
05/09/2024	POOL	666786*#	DENCAP	DENTAL PREMIUMS	71900	1441	285.00
05/29/2024	POOL	667033*#	DEARBORN NATIONAL LIFE INSURANCE	LIFE AND AD&D PREMIUM	71900	1441	507.94
				DISABILITY PREMIUM	71900	1441	947.64

Check Date	Bank	Check #	Payee	Description	Account	Dept	Amount
Fund: 101 GENERAL FUND							
Department: 1441 STREET MAINTENANCE DIV							
				LONG TERM DISABILITY PREMIUM	71900	1441	226.06
				CHECK POOL 667033 TOTAL FOR FUND 101:			<u>1,681.64</u>
				Total for department 1441:			1,966.64
Department: 1442 D P W GARAGE							
05/09/2024	POOL	666781*#	WINDSTREAM COMMUNICATIONS INC	TELEPHONE SERVICE	85300	1442	255.81
05/16/2024	POOL	666792*#	VERIZON WIRELESS	CELLULAR SERVICE	85300	1442	68.89
05/29/2024	POOL	666806	AJAX TRAILERS LLC	VEHICLE MAINTENANCE	86300	1442	15.96
05/29/2024	POOL	666821*#	GRAINGER INC	VEHICLE MAINTENANCE	86300	1442	234.46
				VEHICLE MAINTENANCE	86300	1442	18.00
				VEHICLE MAINTENANCE	86300	1442	9.10
				VEHICLE MAINTENANCE	86300	1442	151.66
				VEHICLE MAINTENANCE	86300	1442	42.32
				VEHICLE MAINTENANCE	86300	1442	73.28
				VEHICLE MAINTENANCE	86300	1442	117.76
				VEHICLE MAINTENANCE	86300	1442	224.96
				VEHICLE MAINTENANCE	86300	1442	71.00
				CHECK POOL 666821 TOTAL FOR FUND 101:			<u>942.54</u>
05/29/2024	POOL	666823*#	HAMILTON CHEVROLET INC	VEHICLE MAINTENANCE	86300	1442	172.73
				VEHICLE MAINTENANCE	86300	1442	97.06
				VEHICLE MAINTENANCE	86300	1442	173.10
				VEHICLE MAINTENANCE	86300	1442	61.64
				VEHICLE MAINTENANCE	86300	1442	125.08
				VEHICLE MAINTENANCE	86300	1442	46.87
				VEHICLE MAINTENANCE	86300	1442	802.31
				VEHICLE MAINTENANCE	86300	1442	12.38
				VEHICLE MAINTENANCE	86300	1442	470.12
				VEHICLE MAINTENANCE	86300	1442	204.51
				CREDIT MEMO	86300	1442	(571.36)
				CHECK POOL 666823 TOTAL FOR FUND 101:			<u>1,594.44</u>
05/29/2024	POOL	666825	JB DLCO-MULTISTATE	VEHICLE MAINTENANCE	86300	1442	703.20
05/29/2024	POOL	666827	TEAM EQUIPMENT COMPANY	TOOLS	74000	1442	198.90
05/29/2024	POOL	666833#	STATE CHEMICAL SOLUTIONS	OPERATING SUPPLY	74000	1442	573.30

Check Date	Bank	Check #	Payee	Description	Account	Dept	Amount
Fund: 101 GENERAL FUND							
Department: 1442 D P W GARAGE							
05/29/2024	POOL	666834	TERMINAL SUPPLY CO	VEHICLE MAINTENANCE	86300	1442	65.53
				VEHICLE MAINTENANCE	86300	1442	45.93
				VEHICLE MAINTENANCE	86300	1442	68.55
				VEHICLE MAINTENANCE	86300	1442	401.70
				VEHICLE MAINTENANCE	86300	1442	811.20
				VEHICLE MAINTENANCE	86300	1442	304.52
				CHECK POOL 666834 TOTAL FOR FUND 101:			<u>1,697.43</u>
05/29/2024	POOL	666835*#	CITY OF WARREN	WATER SERVICE	92000	1442	165.29
				WATER SERVICE	92000	1442	21.57
				WATER SERVICE	92000	1442	21.57
				WATER SERVICE	92000	1442	656.28
				WATER SERVICE	92000	1442	417.83
				CHECK POOL 666835 TOTAL FOR FUND 101:			<u>1,282.54</u>
05/29/2024	POOL	666837*#	WARREN PIPE & SUPPLY CO	OPERATING SUPPLY	74000	1442	54.65
				OPERATING SUPPLY	74000	1442	67.47
				OPERATING SUPPLY	74000	1442	56.12
				CHECK POOL 666837 TOTAL FOR FUND 101:			<u>178.24</u>
05/29/2024	POOL	666840*#	WHOLESALE TOOL CO	TOOLS	74000	1442	79.20
05/29/2024	POOL	666842	JOHN R SPRING & TIRE CTR	VEHICLE MAINTENANCE	86300	1442	4,106.21
05/29/2024	POOL	666851	PIRTEK	VEHICLE MAINTENANCE	86300	1442	340.26
05/29/2024	POOL	666855	SERVICE TOWING INC	VEHICLE MAINTENANCE	86300	1442	85.00
				VEHICLE MAINTENANCE	86300	1442	85.00
				VEHICLE MAINTENANCE	86300	1442	310.00
				VEHICLE MAINTENANCE	86300	1442	85.00
				CHECK POOL 666855 TOTAL FOR FUND 101:			<u>565.00</u>
05/29/2024	POOL	666858*#	CANFIELD EQUIP SVC INC	VEHICLE MAINTENANCE	86300	1442	810.00
05/29/2024	POOL	666865*#	AIRGAS USA LLC	OPERATING SUPPLY	74000	1442	229.95
				OPERATING SUPPLY	74000	1442	127.03
				OPERATING SUPPLY	74000	1442	77.99

Check Date	Bank	Check #	Payee	Description	Account	Dept	Amount
Fund: 101 GENERAL FUND							
Department: 1442 D P W GARAGE							
				OPERATING SUPPLY	74000	1442	297.78
				CHECK POOL 666865 TOTAL FOR FUND 101:			<u>732.75</u>
05/29/2024	POOL	666871	GOODYEAR TIRE & RUBBER CO	VEHICLE MAINTENANCE	86300	1442	318.00
				VEHICLE MAINTENANCE	86300	1442	563.00
				VEHICLE MAINTENANCE	86300	1442	557.00
				VEHICLE MAINTENANCE	86300	1442	127.98
				VEHICLE MAINTENANCE	86300	1442	819.08
				VEHICLE MAINTENANCE	86300	1442	270.00
				VEHICLE MAINTENANCE	86300	1442	118.26
				CHECK POOL 666871 TOTAL FOR FUND 101:			<u>2,773.32</u>
05/29/2024	POOL	666872	TRACTION HEAVY DUTY PARTS	VEHICLE MAINTENANCE	86300	1442	130.41
				VEHICLE MAINTENANCE	86300	1442	138.00
				CHECK POOL 666872 TOTAL FOR FUND 101:			<u>268.41</u>
05/29/2024	POOL	666888	APOLLO FIRE APPARATUS SALES &	VEHICLE MAINTENANCE	86300	1442	293.75
05/29/2024	POOL	666890	DEPENDABLE WHOLESALE INC	VEHICLE MAINTENANCE	86300	1442	28.50
				VEHICLE MAINTENANCE	86300	1442	509.05
				VEHICLE MAINTENANCE	86300	1442	28.50
				VEHICLE MAINTENANCE	86300	1442	1,308.50
				VEHICLE MAINTENANCE	86300	1442	2,546.00
				VEHICLE MAINTENANCE	86300	1442	344.50
				VEHICLE MAINTENANCE	86300	1442	1,712.00
				VEHICLE MAINTENANCE	86300	1442	1,392.95
				VEHICLE MAINTENANCE	86300	1442	2,741.05
				VEHICLE MAINTENANCE	86300	1442	610.79
				VEHICLE MAINTENANCE	86300	1442	5.00
				VEHICLE MAINTENANCE	86300	1442	753.20
				VEHICLE MAINTENANCE	86300	1442	1,230.00
				VEHICLE MAINTENANCE	86300	1442	615.00
				VEHICLE MAINTENANCE	86300	1442	344.50
				VEHICLE MAINTENANCE	86300	1442	495.30
				CREDIT MEMO	86300	1442	(35.00)
				CHECK POOL 666890 TOTAL FOR FUND 101:			<u>14,629.84</u>
05/29/2024	POOL	666898	AIS CONSTRUCTION EQUIPMENT	VEHICLE MAINTENANCE	86300	1442	531.72
				VEHICLE MAINTENANCE	86300	1442	155.42

Check Date	Bank	Check #	Payee	Description	Account	Dept	Amount
Fund: 101 GENERAL FUND							
Department: 1442 D P W GARAGE							
				VEHICLE MAINTENANCE	86300	1442	176.66
				CHECK POOL 666898 TOTAL FOR FUND 101:			<u>863.80</u>
05/29/2024	POOL	666902	HD EDWARDS & CO	OPERATING SUPPLY	74000	1442	503.20
05/29/2024	POOL	666913*#	GOV CONNECTION INC	ADOBE CREATIVE CLOUD	74000	1442	89.99
05/29/2024	POOL	666935	TRUCK AND TRAILER	VEHICLE MAINTENANCE	86300	1442	1,268.87
05/29/2024	POOL	666942	EMERGENCY VEHICLES PLUS	VEHICLE MAINTENANCE	86300	1442	1,377.96
				VEHICLE MAINTENANCE	86300	1442	371.70
				VEHICLE MAINTENANCE	86300	1442	621.65
				CHECK POOL 666942 TOTAL FOR FUND 101:			<u>2,371.31</u>
05/29/2024	POOL	666943#	HELLEBUYCKS POWER EQUIP	OPERATING SUPPLY	74000	1442	630.92
				OPERATING SUPPLY	74000	1442	280.27
				CHECK POOL 666943 TOTAL FOR FUND 101:			<u>911.19</u>
05/29/2024	POOL	666965	FLEET PRIDE HEAVY DUTY	VEHICLE MAINTENANCE	86300	1442	219.90
05/29/2024	POOL	666985	GENUINE PARTS COMPANY	VEHICLE MAINTENANCE	86300	1442	561.17
				VEHICLE MAINTENANCE	86300	1442	158.04
				VEHICLE MAINTENANCE	86300	1442	372.28
				VEHICLE MAINTENANCE	86300	1442	85.60
				VEHICLE MAINTENANCE	86300	1442	216.68
				VEHICLE MAINTENANCE	86300	1442	37.21
				VEHICLE MAINTENANCE	86300	1442	724.55
				VEHICLE MAINTENANCE	86300	1442	29.90
				VEHICLE MAINTENANCE	86300	1442	140.94
				VEHICLE MAINTENANCE	86300	1442	268.72
				VEHICLE MAINTENANCE	86300	1442	22.71
				VEHICLE MAINTENANCE	86300	1442	26.82
				VEHICLE MAINTENANCE	86300	1442	4.28
				VEHICLE MAINTENANCE	86300	1442	6.24
				VEHICLE MAINTENANCE	86300	1442	10.26
				VEHICLE MAINTENANCE	86300	1442	297.00
				VEHICLE MAINTENANCE	86300	1442	23.92
				VEHICLE MAINTENANCE	86300	1442	62.82
				VEHICLE MAINTENANCE	86300	1442	156.64
				VEHICLE MAINTENANCE	86300	1442	24.32
				VEHICLE MAINTENANCE	86300	1442	6.04

05/22/2024 11:26 AM
 User: tcameron
 DB: Warren

CHECK DISBURSEMENT REPORT FOR CITY OF WARREN
 CHECK NUMBER 666777 - 667227

Check Date	Bank	Check #	Payee	Description	Account	Dept	Amount
Fund: 101 GENERAL FUND							
Department: 1442 D P W GARAGE							
				VEHICLE MAINTENANCE	86300	1442	90.73
				VEHICLE MAINTENANCE	86300	1442	12.42
				VEHICLE MAINTENANCE	86300	1442	120.20
				VEHICLE MAINTENANCE	86300	1442	174.78
				VEHICLE MAINTENANCE	86300	1442	247.75
				CREDIT MEMO	86300	1442	(20.25)
				CREDIT MEMO	86300	1442	(130.72)
				CHECK POOL 666985 TOTAL FOR FUND 101:			<u>3,731.05</u>
05/29/2024	POOL	666986*#	APPLIED INNOVATION	COPIER MAINTENANCE	74000	1442	17.70
				COPIER MAINTENANCE	74000	1442	11.80
				CHECK POOL 666986 TOTAL FOR FUND 101:			<u>29.50</u>
05/29/2024	POOL	666994	FOUR SEASONS RADIATOR	VEHICLE MAINTENANCE	86300	1442	485.00
05/29/2024	POOL	666996	CHEMSEARCH	MAINTENANCE SUPPLY	74000	1442	488.95
05/29/2024	POOL	667009	CCP INDUSTRIES	MAINTENANCE SUPPLY	74000	1442	766.45
05/29/2024	POOL	667013	MSC INDUSTRIAL SUPPLY	VEHICLE MAINTENANCE	86300	1442	152.08
				VEHICLE MAINTENANCE	86300	1442	64.29
				VEHICLE MAINTENANCE	86300	1442	192.53
				VEHICLE MAINTENANCE	86300	1442	52.27
				CHECK POOL 667013 TOTAL FOR FUND 101:			<u>461.17</u>
05/29/2024	POOL	667018	M & K HOLDING COMPANY	VEHICLE MAINTENANCE	86300	1442	4,573.84
				VEHICLE MAINTENANCE	86300	1442	360.92
				VEHICLE MAINTENANCE	86300	1442	170.00
				VEHICLE MAINTENANCE	86300	1442	118.88
				VEHICLE MAINTENANCE	86300	1442	20.15
				VEHICLE MAINTENANCE	86300	1442	330.60
				VEHICLE MAINTENANCE	86300	1442	232.50
				VEHICLE MAINTENANCE	86300	1442	5,510.28
				CREDIT MEMO	86300	1442	(375.00)
				CREDIT MEMO	86300	1442	(540.23)
				CHECK POOL 667018 TOTAL FOR FUND 101:			<u>10,401.94</u>
05/29/2024	POOL	667029*#	BESTES LANDSCAPING SUPPLIES	LANDSCAPING SUPPLY	74000	1442	473.99
05/29/2024	POOL	667033*#	DEARBORN NATIONAL LIFE INSURANCE	LIFE AND AD&D PREMIUM	71900	1442	270.84

05/22/2024 11:26 AM
 User: tcameron
 DB: Warren

CHECK DISBURSEMENT REPORT FOR CITY OF WARREN
 CHECK NUMBER 666777 - 667227

Check Date	Bank	Check #	Payee	Description	Account	Dept	Amount
Fund: 101 GENERAL FUND							
Department: 1442 D P W GARAGE							
				DISABILITY PREMIUM	71900	1442	505.02
				LONG TERM DISABILITY PREMIUM	71900	1442	134.16
				CHECK POOL 667033 TOTAL FOR FUND 101:			<u>910.02</u>
05/29/2024	POOL	667054*#	AMERICAN PEST CONTROL INC	PEST CONTROL SERVICES	80100	1442	28.00
05/29/2024	POOL	667069	LAWSON PRODUCTS INC	VEHICLE MAINTENANCE	86300	1442	9.63
				VEHICLE MAINTENANCE	86300	1442	53.52
				VEHICLE MAINTENANCE	86300	1442	154.35
				VEHICLE MAINTENANCE	86300	1442	45.90
				VEHICLE MAINTENANCE	86300	1442	608.02
				VEHICLE MAINTENANCE	86300	1442	139.30
				CHECK POOL 667069 TOTAL FOR FUND 101:			<u>1,010.72</u>
05/29/2024	POOL	667085	ARC IMAGING RESOURCES	SIGN MAKING SUPPLIES	74000	1442	780.00
05/29/2024	POOL	667092	LIMB WALKERS TREE & SNOW	TREE MAINTENANCE	81400	1442	6,380.00
				TREE MAINTENANCE	81400	1442	3,335.00
				TREE MAINTENANCE	81400	1442	8,700.00
				CHECK POOL 667092 TOTAL FOR FUND 101:			<u>18,415.00</u>
05/29/2024	POOL	667098*#	ODP BUSINESS SOLUTIONS LLC	OFFICE SUPPLY	74000	1442	24.70
				OFFICE SUPPLY	74000	1442	1,458.83
				CHECK POOL 667098 TOTAL FOR FUND 101:			<u>1,483.53</u>
05/29/2024	POOL	667108	VERIZON CONNECT FLEET USA LLC	ASSET MANAGEMENT	80100	1442	9,380.87
05/29/2024	POOL	667113*#	BMW KAR WASH LLC	VEHICLE MAINTENANCE	86300	1442	9.50
05/29/2024	POOL	667123	FRIENDLY CHRYSLER JEEP	VEHICLE MAINTENANCE	86300	1442	395.60
				VEHICLE MAINTENANCE	86300	1442	364.80
				CHECK POOL 667123 TOTAL FOR FUND 101:			<u>760.40</u>
05/29/2024	POOL	667156	MOTOR CITY INDUSTRIAL	VEHICLE MAINTENANCE	86300	1442	9.49
05/29/2024	POOL	667163	MACQUEEN	VEHICLE MAINTENANCE	86300	1442	344.85
				VEHICLE MAINTENANCE	86300	1442	577.20
				VEHICLE MAINTENANCE	86300	1442	940.64

Check Date	Bank	Check #	Payee	Description	Account	Dept	Amount
Fund: 101 GENERAL FUND							
Department: 1442 D P W GARAGE							
				VEHICLE MAINTENANCE	86300	1442	97.38
				VEHICLE MAINTENANCE	86300	1442	475.58
				VEHICLE MAINTENANCE	86300	1442	251.09
				VEHICLE MAINTENANCE	86300	1442	7,301.92
				VEHICLE MAINTENANCE	86300	1442	401.38
				VEHICLE MAINTENANCE	86300	1442	3,874.50
				VEHICLE MAINTENANCE	86300	1442	126.47
				VEHICLE MAINTENANCE	86300	1442	935.65
				VEHICLE MAINTENANCE	86300	1442	422.83
				VEHICLE MAINTENANCE	86300	1442	12,319.33
				VEHICLE MAINTENANCE	86300	1442	123.04
				VEHICLE MAINTENANCE	86300	1442	272.54
				VEHICLE MAINTENANCE	86300	1442	264.27
				CHECK POOL 667163 TOTAL FOR FUND 101:			<u>28,728.67</u>
05/29/2024	POOL	667218*#	FERGUSON WATERWORKS	OPERATING SUPPLY	74000	1442	631.51
05/29/2024	POOL	667219	OWEN TREE SERVICE INC	TREE/STUMP REMOVAL	81400	1442	4,920.00
				TREE/STUMP REMOVAL	81400	1442	4,500.00
				TREE/STUMP REMOVAL	81400	1442	4,920.00
				TREE/STUMP REMOVAL	81400	1442	1,640.00
				TREE/STUMP REMOVAL	81400	1442	3,280.00
				TREE/STUMP REMOVAL	81400	1442	1,640.00
				TREE/STUMP REMOVAL	81400	1442	1,640.00
				TREE/STUMP REMOVAL	81400	1442	1,640.00
				TREE/STUMP REMOVAL	81400	1442	1,640.00
				TREE/STUMP REMOVAL	81400	1442	4,920.00
				TREE/STUMP REMOVAL	81400	1442	1,640.00
				TREE/STUMP REMOVAL	81400	1442	3,280.00
				TREE/STUMP REMOVAL	81400	1442	6,560.00
				TREE/STUMP REMOVAL	81400	1442	3,280.00
				TREE/STUMP REMOVAL	81400	1442	1,640.00
				TREE/STUMP REMOVAL	81400	1442	4,920.00
				TREE/STUMP REMOVAL	81400	1442	4,920.00
				TREE/STUMP REMOVAL	81400	1442	3,280.00
				TREE/STUMP REMOVAL	81400	1442	3,280.00
				TREE/STUMP REMOVAL	81400	1442	4,920.00
				TREE/STUMP REMOVAL	81400	1442	4,920.00
				TREE/STUMP REMOVAL	81400	1442	3,280.00
				TREE/STUMP REMOVAL	81400	1442	3,280.00
				TREE/STUMP REMOVAL	81400	1442	4,920.00
				TREE/STUMP REMOVAL	81400	1442	4,920.00
				TREE/STUMP REMOVAL	81400	1442	1,640.00
				TREE/STUMP REMOVAL	81400	1442	1,640.00
				TREE/STUMP REMOVAL	81400	1442	3,280.00

Check Date	Bank	Check #	Payee	Description	Account	Dept	Amount
Fund: 101 GENERAL FUND							
Department: 1442 D P W GARAGE							
				TREE/STUMP REMOVAL	81400	1442	3,280.00
				TREE/STUMP REMOVAL	81400	1442	1,640.00
				TREE/STUMP REMOVAL	81400	1442	1,640.00
				TREE/STUMP REMOVAL	81400	1442	1,640.00
				TREE/STUMP REMOVAL	81400	1442	3,280.00
				TREE/STUMP REMOVAL	81400	1442	3,280.00
				TREE/STUMP REMOVAL	81400	1442	1,640.00
				TREE/STUMP REMOVAL	81400	1442	3,280.00
				TREE/STUMP REMOVAL	81400	1442	3,280.00
				TREE/STUMP REMOVAL	81400	1442	1,640.00
				TREE/STUMP REMOVAL	81400	1442	1,640.00
				TREE/STUMP REMOVAL	81400	1442	3,280.00
				TREE/STUMP REMOVAL	81400	1442	4,920.00
				TREE/STUMP REMOVAL	81400	1442	1,640.00
				TREE/STUMP REMOVAL	81400	1442	1,640.00
				TREE/STUMP REMOVAL	81400	1442	4,870.00
				TREE/STUMP REMOVAL	81400	1442	1,640.00
				TREE TRIMMING	81400	1442	6,073.84
				TREE TRIMMING	81400	1442	8,912.70
				TREE TRIMMING	81400	1442	3,433.04
				TREE TRIMMING	81400	1442	4,819.46
				TREE TRIMMING	81400	1442	11,817.58
				TREE TRIMMING	81400	1442	13,137.98
				TREE TRIMMING	81400	1442	7,988.42
				TREE TRIMMING	81400	1442	11,751.56
				TREE TRIMMING	81400	1442	1,320.40
				TREE TRIMMING	81400	1442	1,518.46
				TREE TRIMMING	81400	1442	4,687.42
				CHECK POOL 667219 TOTAL FOR FUND 101:			<u>206,190.86</u>
05/29/2024	POOL	667220	WOLVERINE FREIGHTLINER EASTSIDE	VEHICLE MAINTENANCE	86300	1442	283.86
				VEHICLE MAINTENANCE	86300	1442	248.34
				VEHICLE MAINTENANCE	86300	1442	171.99
				CREDIT MEMO	86300	1442	(62.50)
				CREDIT MEMO	86300	1442	(250.00)
				CHECK POOL 667220 TOTAL FOR FUND 101:			<u>391.69</u>
05/29/2024	POOL	667221#	GARRETT DOOR CO	OVERHEAD DOOR SERVICE	93000	1442	680.00
				OVERHEAD DOOR SERVICE	93000	1442	153.95

Check Date	Bank	Check #	Payee	Description	Account	Dept	Amount
Fund: 101 GENERAL FUND							
Department: 1442 D P W GARAGE							
CHECK POOL 667221 TOTAL FOR FUND 101:							833.95
05/29/2024	POOL	667222	CREST FORD INC	VEHICLE MAINTENANCE	86300	1442	190.90
				VEHICLE MAINTENANCE	86300	1442	630.72
				VEHICLE MAINTENANCE	86300	1442	53.46
				VEHICLE MAINTENANCE	86300	1442	77.00
				VEHICLE MAINTENANCE	86300	1442	630.72
				VEHICLE MAINTENANCE	86300	1442	68.31
				VEHICLE MAINTENANCE	86300	1442	256.44
CHECK POOL 667222 TOTAL FOR FUND 101:							1,907.55
05/29/2024	POOL	667226	COMMPAR LLC	VEHICLE MAINTENANCE	86300	1442	1,142.22
				VEHICLE MAINTENANCE	86300	1442	655.60
CHECK POOL 667226 TOTAL FOR FUND 101:							1,797.82
Total for department 1442:							328,445.88
Department: 1447 ENGINEERING & INSPECTIONS							
05/09/2024	POOL	666786*#	DENCAP	DENTAL PREMIUMS	71900	1447	57.00
05/16/2024	POOL	666792*#	VERIZON WIRELESS	CELLULAR SERVICE	85300	1447	106.27
05/29/2024	POOL	666984	DANIELLE HARDEN	COURT RECORDING SERVICES	80100	1447	175.00
05/29/2024	POOL	667033*#	DEARBORN NATIONAL LIFE INSURANCE	LIFE AND AD&D PREMIUM	71900	1447	132.90
				DISABILITY PREMIUM	71900	1447	248.38
				LONG TERM DISABILITY PREMIUM	71900	1447	69.25
CHECK POOL 667033 TOTAL FOR FUND 101:							450.53
Total for department 1447:							788.80
Department: 1448 HIGHWAY STREET LIGHTING							
05/16/2024	POOL	666789*#	DTE ENERGY	STREET LIGHTING	92600	1448	281,671.30
Total for department 1448:							281,671.30
Department: 1779 COUNCIL OF COMMISSIONS							
05/29/2024	POOL	666843	UKRAINIAN CULTURAL CENTER	APPRECIATION DINNER	96137	1779	1,711.14
				APPRECIATION DINNER	96137	1779	296.33
CHECK POOL 666843 TOTAL FOR FUND 101:							2,007.47

Check Date	Bank	Check #	Payee	Description	Account	Dept	Amount
Fund: 101 GENERAL FUND							
Department: 1779 COUNCIL OF COMMISSIONS							
Total for department 1779:							2,007.47
Department: 1780 ANIMAL RIGHTS COMMISSION							
05/29/2024	POOL	667084*#	SKIP PRINTING COMPANY	PRINTING	96138	1780	648.00
				PRINTING	96138	1780	162.00
CHECK POOL 667084 TOTAL FOR FUND 101:							810.00
Total for department 1780:							810.00
Department: 1793 BEAUTIFICATION							
05/09/2024	POOL	666781*#	WINDSTREAM COMMUNICATIONS INC	TELEPHONE SERVICE	85300	1793	3.87
05/29/2024	POOL	666835*#	CITY OF WARREN	WATER SERVICE	92000	1793	12.40
05/29/2024	POOL	666914#	GEMINI FORMS & SYSTEMS	PRINTING	96103	1793	248.70
				PRINTING	96103	1793	40.00
				AWARD SUPPLY	96104	1793	147.50
				AWARD SUPPLY	96104	1793	25.00
				AWARD SUPPLY	96104	1793	17.92
CHECK POOL 666914 TOTAL FOR FUND 101:							479.12
05/29/2024	POOL	666947	EUGENIA PALMER	MILEAGE	86100	1793	84.20
Total for department 1793:							579.59
Department: 1794 CULTURAL COMMISSION							
05/29/2024	POOL	666933	RICHARD M KOWALEWSKI	FEATURE PERFORMANCE	96115	1794	500.00
05/29/2024	POOL	667130	ALFRED JONES III	PERFORMANCE	96110	1794	3,000.00
				PERFORMANCE	96115	1794	250.00
CHECK POOL 667130 TOTAL FOR FUND 101:							3,250.00
05/29/2024	POOL	667131	ALFRED JONES III	PERFORMANCE	80140	1794	3,000.00
				PERFORMANCE	96115	1794	250.00
CHECK POOL 667131 TOTAL FOR FUND 101:							3,250.00
Total for department 1794:							7,000.00
Department: 1795 HISTORICAL COMMISSION							
05/09/2024	POOL	666781*#	WINDSTREAM COMMUNICATIONS INC	TELEPHONE SERVICE	85300	1795	3.87
Total for department 1795:							3.87

05/22/2024 11:26 AM
User: tcameron
DB: Warren

CHECK DISBURSEMENT REPORT FOR CITY OF WARREN
CHECK NUMBER 666777 - 667227

Check Date	Bank	Check #	Payee	Description	Account	Dept	Amount
Fund: 101 GENERAL FUND							
Department: 1796 VILLAGE HISTORICAL COMM							
05/16/2024	POOL	666788*#	DTE ENERGY	ELECTRIC SERVICE	92000	1796	35.29
05/29/2024	POOL	666835*#	CITY OF WARREN	WATER SERVICE	92000	1796	10.79
Total for department 1796:							46.08
Total for fund 101 GENERAL FUND							1,369,096.50

Check Date	Bank	Check #	Payee	Description	Account	Dept	Amount
Fund: 202 MTF ACT 51 MAJOR OPERATNG							
Department: 0000							
05/29/2024	POOL	667008	HUNTINGTON NATIONAL BANK	AGENCY FEE	12300	0000	500.00
Total for department 0000:							500.00
Department: 2451 CONSTRUCTION							
05/29/2024	POOL	666900	MDOT	M-102 MILL AND RESURFACING	97400	2451	190.07
Total for department 2451:							190.07
Department: 2463 ROUTINE MAINTENANCE							
05/29/2024	POOL	666936*#	JH HART URBAN FORESTRY	BRANCH/LOG DISPOSAL	80100	2463	315.00
Total for department 2463:							315.00
Department: 2474 TRAFFIC SERVICES							
05/16/2024	POOL	666789*#	DTE ENERGY	STREET LIGHTING	80121	2474	1,088.44
Total for department 2474:							1,088.44
Total for fund 202 MTF ACT 51 MAJOR OPERATNG							2,093.51

Check Date	Bank	Check #	Payee	Description	Account	Dept	Amount
Fund: 203 MTF ACT 51 LOCAL OPERATNG							
Department: 3463 ROUTINE MAINTENANCE							
05/29/2024	POOL	666936*#	JH HART URBAN FORESTRY	BRANCH/LOG DISPOSAL	80100	3463	315.00
05/29/2024	POOL	667151	BIG BARNEY'S ROAD MAINTENANCE	LIQUID CALCIUM CHLORIDE	80100	3463	4,553.00
				LIQUID CALCIUM CHLORIDE	80100	3463	4,611.00
				LIQUID CALCIUM CHLORIDE	80100	3463	638.00
				CHECK POOL 667151 TOTAL FOR FUND 203:			<u>9,802.00</u>
				Total for department 3463:			10,117.00
Department: 3474 TRAFFIC SERVICES							
05/16/2024	POOL	666789*#	DTE ENERGY	STREET LIGHTING	80121	3474	5,314.13
				Total for department 3474:			5,314.13
				Total for fund 203 MTF ACT 51 LOCAL OPERATNG			15,431.13

Check Date	Bank	Check #	Payee	Description	Account	Dept	Amount
Fund: 204 2011 LOCAL STREET R&M							
Department: 0000							
05/29/2024	POOL	666820*#	FLORENCE CEMENT CO	WATER MAIN AND PAVEMENT RECONSTRUCTION	21000	0000	(236,974.96)
				WATER MAIN AND PAVEMENT RECONSTRUCTION	21001	0000	(23,697.50)
				WATER MAIN AND PAVEMENT RECONSTRUCTION	21132	0000	236,974.96
				CHECK POOL 666820 TOTAL FOR FUND 204:			<u>(23,697.50)</u>
05/29/2024	POOL	666921#	ZUNIGA CEMENT CONSTRUCTION INC	PAVEMENT RECONSTRUCTION	21000	0000	(334,492.80)
				PAVEMENT RECONSTRUCTION	21001	0000	(33,449.28)
				PAVEMENT RECONSTRUCTION	21126	0000	334,492.80
				CHECK POOL 666921 TOTAL FOR FUND 204:			<u>(33,449.28)</u>
05/29/2024	POOL	667044*#	MARK ANTHONY CONTRACTING INC	ROAD CONSTRUCTION AND WATER MAIN	21000	0000	(312,483.61)
				ROAD CONSTRUCTION AND WATER MAIN	21001	0000	(31,248.35)
				ROAD CONSTRUCTION AND WATER MAIN	21122	0000	312,483.61
				CHECK POOL 667044 TOTAL FOR FUND 204:			<u>(31,248.35)</u>
05/29/2024	POOL	667045#	MARK ANTHONY CONTRACTING INC	PARKING LOT RECONSTRUCTION	21000	0000	(293,050.00)
				PARKING LOT RECONSTRUCTION	21001	0000	(29,305.00)
				PARKING LOT RECONSTRUCTION	21124	0000	293,050.00
				CHECK POOL 667045 TOTAL FOR FUND 204:			<u>(29,305.00)</u>
05/29/2024	POOL	667073#	GREAT LAKES CONTRACTING	ROAD RECONSTRUCTION	21000	0000	(200,300.78)
				ROAD RECONSTRUCTION	21081	0000	200,300.78
				CHECK POOL 667073 TOTAL FOR FUND 204:			<u>0.00</u>
				Total for department 0000:			(117,700.13)
Department: 9204 2011 LOCAL ST REPAIR EXP							
05/29/2024	POOL	666820*#	FLORENCE CEMENT CO	WATER MAIN AND PAVEMENT RECONSTRUCTION	97400	9204	236,974.97
05/29/2024	POOL	666921#	ZUNIGA CEMENT CONSTRUCTION INC	PAVEMENT RECONSTRUCTION	97400	9204	334,492.80
05/29/2024	POOL	667044*#	MARK ANTHONY CONTRACTING INC	ROAD CONSTRUCTION AND WATER MAIN	97400	9204	312,483.61
05/29/2024	POOL	667045#	MARK ANTHONY CONTRACTING INC	PARKING LOT RECONSTRUCTION	97400	9204	293,050.00
05/29/2024	POOL	667073#	GREAT LAKES CONTRACTING	ROAD RECONSTRUCTION	97400	9204	200,300.78

Check Date	Bank	Check #	Payee	Description	Account	Dept	Amount
------------	------	---------	-------	-------------	---------	------	--------

Fund: 204 2011 LOCAL STREET R&M

Department: 9204 2011 LOCAL ST REPAIR EXP

Total for department 9204: 1,377,302.16

Total for fund 204 2011 LOCAL STREET R&M 1,259,602.03

Check Date	Bank	Check #	Payee	Description	Account	Dept	Amount
Fund: 208 RECREATION SPEC REVENUE							
Department: 0000							
05/29/2024	POOL	666949*#	RKA PETROLEUM COMPANIES	GASOLINE	10700	0000	909.89
				GASOLINE	10700	0000	1,803.23
				CHECK POOL 666949 TOTAL FOR FUND 208:			<u>2,713.12</u>
05/29/2024	POOL	666997*#	WOW! BUSINESS	HIGH SPEED INTERNET	12300	0000	774.90
				Total for department 0000:			3,488.02
Department: 9208 RECREATION EXPENDITURES							
05/09/2024	POOL	666779	AT&T	MONTHLY PHONE SERVICE	85300	9208	51.28
05/09/2024	POOL	666781*#	WINDSTREAM COMMUNICATIONS INC	TELEPHONE SERVICE	85300	9208	3.28
				TELEPHONE SERVICE	85300	9208	123.80
				TELEPHONE SERVICE	85300	9208	150.00
				TELEPHONE SERVICE	85300	9208	8.67
				TELEPHONE SERVICE	85300	9208	234.33
				TELEPHONE SERVICE	85300	9208	248.51
				TELEPHONE SERVICE	85300	9208	250.17
				CHECK POOL 666781 TOTAL FOR FUND 208:			<u>1,018.76</u>
05/09/2024	POOL	666786*#	DENCAP	DENTAL PREMIUMS	71900	9208	57.00
05/16/2024	POOL	666788*#	DTE ENERGY	ELECTRIC SERVICE	92000	9208	791.09
				ELECTRIC SERVICE	92000	9208	36.84
				ELECTRIC SERVICE	92000	9208	17.63
				CHECK POOL 666788 TOTAL FOR FUND 208:			<u>845.56</u>
05/16/2024	POOL	666792*#	VERIZON WIRELESS	CELLULAR SERVICE	85300	9208	32.52
05/16/2024	POOL	666795	AVERY BRIONES	OFFICIAL	70713	9208	252.00
05/29/2024	POOL	666819	FIRE EXTINGUISHER SALES &	FIRE EXTINGUISHER MAINTENANCE	93000	9208	741.55
05/29/2024	POOL	666821*#	GRAINGER INC	MAINTENANCE SUPPLY	77600	9208	670.99
				MAINTENANCE SUPPLY	77600	9208	156.45
				MAINTENANCE SUPPLY	77600	9208	183.86
				MAINTENANCE SUPPLY	77600	9208	15.38
				MAINTENANCE SUPPLY	77600	9208	62.43
				MAINTENANCE SUPPLY	77600	9208	332.75
				MAINTENANCE SUPPLY	77600	9208	74.58

Check Date	Bank	Check #	Payee	Description	Account	Dept	Amount
Fund: 208 RECREATION SPEC REVENUE							
Department: 9208 RECREATION EXPENDITURES							
CHECK POOL 666821 TOTAL FOR FUND 208:							1,496.44
05/29/2024	POOL	666831*#	SUPPLYDEN INC	JANITORIAL SUPPLY	77600	9208	7.50
				JANITORIAL SUPPLY	77600	9208	1,952.16
CHECK POOL 666831 TOTAL FOR FUND 208:							1,959.66
05/29/2024	POOL	666835*#	CITY OF WARREN	WATER SERVICE	92000	9208	165.29
				WATER SERVICE	92000	9208	165.29
				WATER SERVICE	92000	9208	30.18
				WATER SERVICE	92000	9208	165.29
				WATER SERVICE	92000	9208	122.24
				WATER SERVICE	92000	9208	122.24
				WATER SERVICE	92000	9208	6,044.00
				WATER SERVICE	92000	9208	122.24
				WATER SERVICE	92000	9208	165.29
				WATER SERVICE	92000	9208	53.62
				WATER SERVICE	92000	9208	165.29
				WATER SERVICE	92000	9208	370.54
				WATER SERVICE	92000	9208	165.29
				WATER SERVICE	92000	9208	165.29
				WATER SERVICE	92000	9208	9.35
				WATER SERVICE	92000	9208	165.29
				WATER SERVICE	92000	9208	9.35
				WATER SERVICE	92000	9208	2,441.31
				WATER SERVICE	92000	9208	18.70
CHECK POOL 666835 TOTAL FOR FUND 208:							10,666.09
05/29/2024	POOL	666837*#	WARREN PIPE & SUPPLY CO	MAINTENANCE SUPPLY	77600	9208	246.74
05/29/2024	POOL	666838	WEINGARTZ SUPPLY	MAINTENANCE EQUIPMENT	98411	9208	157.17
05/29/2024	POOL	666840*#	WHOLESALE TOOL CO	OPERATING SUPPLY	77600	9208	128.95
				OPERATING SUPPLY	77600	9208	106.00
CHECK POOL 666840 TOTAL FOR FUND 208:							234.95
05/29/2024	POOL	666852	VICKI NORMAN	TAI CHI INSTRUCTOR	70713	9208	135.00
05/29/2024	POOL	666866*#	SCHENA ROOFING & SHEET	BUILDING MAINTENANCE	80100	9208	2,625.00

Check Date	Bank	Check #	Payee	Description	Account	Dept	Amount
Fund: 208 RECREATION SPEC REVENUE							
Department: 9208 RECREATION EXPENDITURES							
05/29/2024	POOL	666886*#	HOME DEPOT CREDIT SERVICE	MAINTENANCE SUPPLY	80100	9208	94.86
				MAINTENANCE SUPPLY	80100	9208	381.03
				MAINTENANCE SUPPLY	80100	9208	453.03
				CHECK POOL 666886 TOTAL FOR FUND 208:			<u>928.92</u>
05/29/2024	POOL	666893*#	GORDON FOOD SERVICE INC	EVENT SUPPLY	96126	9208	149.94
				EVENT SUPPLY	96126	9208	25.98
				EVENT SUPPLY	96126	9208	221.86
				CHECK POOL 666893 TOTAL FOR FUND 208:			<u>397.78</u>
05/29/2024	POOL	666905	B & B POOLS & SPA CORP	CHLORINATOR BRIQUETTES	77600	9208	4,440.00
05/29/2024	POOL	666906	LIFEGUARD STORE THE	OPERATING SUPPLY	76000	9208	296.73
05/29/2024	POOL	666910*#	BOUND TREE MEDICAL	MEDICAL SUPPLY	77600	9208	123.49
05/29/2024	POOL	666923	LISA E BIGGS	GYMNASTICS INSTRUCTOR	70713	9208	1,530.00
05/29/2024	POOL	666975	CITY ELECTRIC SUPPLY	ELECTRICAL SUPPLY	93000	9208	49.90
05/29/2024	POOL	666979	LABELSTOP	ATHLETICS APPAREL	76000	9208	600.00
05/29/2024	POOL	666982*#	GREAT LAKES GRAPHICS INC	PRINTING - WATER BILL INSERT	88011	9208	607.77
05/29/2024	POOL	666986*#	APPLIED INNOVATION	COPIER MAINTENANCE	80100	9208	47.20
05/29/2024	POOL	666997*#	WOW! BUSINESS	CABLE FOR WCC	80100	9208	121.12
05/29/2024	POOL	667016	SITE ONE LANDSCAPE SUPPLY	MAINTENANCE SUPPLY	77600	9208	2.18
				MAINTENANCE SUPPLY	77600	9208	183.31
				CHECK POOL 667016 TOTAL FOR FUND 208:			<u>185.49</u>
05/29/2024	POOL	667021	ZERO WASTE USA	WASTE DISPOSAL BAGS	77600	9208	1,841.40
05/29/2024	POOL	667025	BARUZZINI CONTRACTING LLC	POOL/SPA REPAIR	80100	9208	421.00
				LAP POOL FILTER PUMP	97400	9208	14,500.00
				CHECK POOL 667025 TOTAL FOR FUND 208:			<u>14,921.00</u>
05/29/2024	POOL	667026	THE FLYING LOCKSMITHS	BUILDING MAINTENANCE	80100	9208	716.20
				BUILDING MAINTENANCE	80100	9208	614.50

Check Date	Bank	Check #	Payee	Description	Account	Dept	Amount
Fund: 208 RECREATION SPEC REVENUE							
Department: 9208 RECREATION EXPENDITURES							
CHECK POOL 667026 TOTAL FOR FUND 208:							1,330.70
05/29/2024	POOL	667029*#	BESTES LANDSCAPING SUPPLIES	LANDSCAPING SUPPLY	77600	9208	178.50
05/29/2024	POOL	667033*#	DEARBORN NATIONAL LIFE INSURANCE	LIFE AND AD&D PREMIUM	71900	9208	170.20
				DISABILITY PREMIUM	71900	9208	317.90
				LONG TERM DISABILITY PREMIUM	71900	9208	95.30
CHECK POOL 667033 TOTAL FOR FUND 208:							583.40
05/29/2024	POOL	667048*#	PRIORITY WASTE LLC	TRASH REMOVAL	80100	9208	37.62
				TRASH REMOVAL	80100	9208	217.36
				TRASH REMOVAL	80100	9208	300.96
				TRASH REMOVAL	80100	9208	83.60
CHECK POOL 667048 TOTAL FOR FUND 208:							639.54
05/29/2024	POOL	667060	TARGET SPECIALTY PRODUCTS	MAINTENANCE SUPPLIES	76000	9208	700.00
05/29/2024	POOL	667098*#	ODP BUSINESS SOLUTIONS LLC	OFFICE SUPPLY	72700	9208	18.02
				OFFICE SUPPLY	72700	9208	242.21
CHECK POOL 667098 TOTAL FOR FUND 208:							260.23
05/29/2024	POOL	667164	RICHELIEU AMERICA LTD	BUILDING MAINTENANCE	93000	9208	185.59
05/29/2024	POOL	667225*#	USA PLUMBING	PLUMBING SERVICE	80100	9208	321.00
Total for department 9208:							50,809.48
Department: 9210 TRANSPORT EXPENDITURES							
05/09/2024	POOL	666781*#	WINDSTREAM COMMUNICATIONS INC	TELEPHONE SERVICE	85300	9210	50.52
05/29/2024	POOL	666814*#	OCCUPATIONAL HEALTH CENTERS	MEDICAL SERVICE	80100	9210	134.00
05/29/2024	POOL	666835*#	CITY OF WARREN	WATER SERVICE	92000	9210	21.57
				WATER SERVICE	92000	9210	9.05
				WATER SERVICE	92000	9210	49.59
CHECK POOL 666835 TOTAL FOR FUND 208:							80.21
05/29/2024	POOL	666856	INTERSTATE SECURITY INC	ALARM MONITORING	80100	9210	375.00

Check Date	Bank	Check #	Payee	Description	Account	Dept	Amount
Fund: 208 RECREATION SPEC REVENUE							
Department: 9210 TRANSPORT EXPENDITURES							
05/29/2024	POOL	666928	SMART	VEHICLE MAINTENANCE	86300	9210	125.33
05/29/2024	POOL	667054*#	AMERICAN PEST CONTROL INC	PEST CONTROL SERVICE	80100	9210	67.00
				PEST CONTROL SERVICE	80100	9210	58.00
				CHECK POOL 667054 TOTAL FOR FUND 208:			125.00
				Total for department 9210:			890.06
				Total for fund 208 RECREATION SPEC REVENUE			55,187.56

Check Date	Bank	Check #	Payee	Description	Account	Dept	Amount
Fund: 226 SANITATION SPECIAL REV							
Department: 9226 SANITATION EXPENDITURES							
05/09/2024	POOL	666781*#	WINDSTREAM COMMUNICATIONS INC	TELEPHONE SERVICE	85300	9226	42.00
05/09/2024	POOL	666786*#	DENCAP	DENTAL PREMIUMS	71900	9226	342.00
05/29/2024	POOL	666814*#	OCCUPATIONAL HEALTH CENTERS	MEDICAL SERVICE	72700	9226	134.00
05/29/2024	POOL	666815	DOETSCH INDUSTRIAL SERVICES INC	RENTAL-VAC TRUCK	74000	9226	2,710.00
05/29/2024	POOL	666821*#	GRAINGER INC	MAINTENANCE SUPPLY	74000	9226	8.04
05/29/2024	POOL	666831*#	SUPPLYDEN INC	JANITORIAL SUPPLY	74000	9226	401.93
05/29/2024	POOL	666835*#	CITY OF WARREN	WATER SERVICE	92000	9226	165.29
				WATER SERVICE	92000	9226	105.76
				CHECK POOL 666835 TOTAL FOR FUND 226:			<u>271.05</u>
05/29/2024	POOL	666875	SOUTH MACOMB DISPOSAL AUTHORITY	SOLID WASTE/COMPOST	80112	9226	84,422.51
				SOLID WASTE/COMPOST	80115	9226	48,469.95
				CHECK POOL 666875 TOTAL FOR FUND 226:			<u>132,892.46</u>
05/29/2024	POOL	666886*#	HOME DEPOT CREDIT SERVICE	OPERATING SUPPLY	74000	9226	45.94
				MAINTENANCE SUPPLY	93000	9226	209.10
				CHECK POOL 666886 TOTAL FOR FUND 226:			<u>255.04</u>
05/29/2024	POOL	666909	ARC DOCUMENT SOLUTIONS LLC	PRINT SERVICES	72700	9226	1,004.27
05/29/2024	POOL	666949*#	RKA PETROLEUM COMPANIES	GASOLINE/DIESEL FUEL	75100	9226	20,979.61
05/29/2024	POOL	666986*#	APPLIED INNOVATION	COPIER MAINTENANCE	80100	9226	97.37
				COPIER MAINTENANCE	80100	9226	116.25
				CHECK POOL 666986 TOTAL FOR FUND 226:			<u>213.62</u>
05/29/2024	POOL	667020	GFL ENVIRONMENTAL USA INC	COMMINGLED RECYCLING	80115	9226	68,338.75
05/29/2024	POOL	667033*#	DEARBORN NATIONAL LIFE INSURANCE	LIFE AND AD&D PREMIUM	71900	9226	580.46
				DISABILITY PREMIUM	71900	9226	1,082.92
				LONG TERM DISABILITY PREMIUM	71900	9226	284.28

Check Date	Bank	Check #	Payee	Description	Account	Dept	Amount
Fund: 226 SANITATION SPECIAL REV							
Department: 9226 SANITATION EXPENDITURES							
CHECK POOL 667033 TOTAL FOR FUND 226:							1,947.66
05/29/2024	POOL	667054*#	AMERICAN PEST CONTROL INC	MONTHLY PEST CONTROL SERVICE	80100	9226	28.00
				PEST CONTROL SERVICES	80100	9226	65.00
CHECK POOL 667054 TOTAL FOR FUND 226:							93.00
05/29/2024	POOL	667098*#	ODP BUSINESS SOLUTIONS LLC	OFFICE SUPPLY	72700	9226	42.19
05/29/2024	POOL	667113*#	BMW KAR WASH LLC	CAR WASH	74000	9226	4.75
Total for department 9226:							229,680.37
Total for fund 226 SANITATION SPECIAL REV							229,680.37

Check Date	Bank	Check #	Payee	Description	Account	Dept	Amount
Fund: 230 RENTAL ORDINANCE REVENUE							
Department: 9230 RENTAL ORDIN EXPENDITURES							
05/16/2024	POOL	666792*#	VERIZON WIRELESS	CELLULAR SERVICE	85300	9230	28.45
05/29/2024	POOL	667033*#	DEARBORN NATIONAL LIFE INSURANCE	LIFE AND AD&D PREMIUM	71900	9230	118.40
				DISABILITY PREMIUM	71900	9230	221.35
				LONG TERM DISABILITY PREMIUM	71900	9230	61.73
				CHECK POOL 667033 TOTAL FOR FUND 230:			<u>401.48</u>
				Total for department 9230:			429.93
				Total for fund 230 RENTAL ORDINANCE REVENUE			429.93

Check Date	Bank	Check #	Payee	Description	Account	Dept	Amount
Fund: 250 COMMUNICATIONS							
Department: 9250 COMMUNICATION EXPENDITURE							
05/09/2024	POOL	666781*#	WINDSTREAM COMMUNICATIONS INC	TELEPHONE SERVICE	85300	9250	119.93
05/29/2024	POOL	666891*#	B & H PHOTO - VIDEO INC	OPERATING SUPPLIES	74000	9250	149.24
				OPERATING SUPPLIES	74000	9250	258.12
				OPERATING SUPPLIES	74000	9250	174.10
				DVDS/SLEEVES/DVD LABEL SUPPLIES	74001	9250	138.55
				DVDS/SLEEVES/DVD LABEL SUPPLIES	74001	9250	18.70
				DVDS/SLEEVES/DVD LABEL SUPPLIES	74001	9250	77.92
				DVDS/SLEEVES/DVD LABEL SUPPLIES	74001	9250	55.00
				DVDS/SLEEVES/DVD LABEL SUPPLIES	74001	9250	55.00
				DVDS/SLEEVES/DVD LABEL SUPPLIES	74001	9250	71.52
				AUDITORIUM EQUIPMENT SUPPLY	88010	9250	1,924.56
				AUDITORIUM EXPENSE	88010	9250	2,073.60
				AUDITORIUM EXPENSE	88010	9250	604.80
				AUDITORIUM EXPENSE	88010	9250	39.47
				AUDITORIUM SUPPLY	88010	9250	518.40
				AUDITORIUM SUPPLY	88010	9250	1,459.95
				CHECK POOL 666891 TOTAL FOR FUND 250:			<u>7,618.93</u>
05/29/2024	POOL	666913*#	GOV CONNECTION INC	OPERATING SUPPLY	88010	9250	39.43
05/29/2024	POOL	666982*#	GREAT LAKES GRAPHICS INC	PRINTING SERVICE	88001	9250	1,017.50
05/29/2024	POOL	667012	ADVERTISING & GRAPHICS	FIELD APPAREL	88001	9250	15.94
				FIELD APPAREL	88001	9250	33.18
				FIELD APPAREL	88001	9250	82.95
				FIELD APPAREL	88001	9250	19.48
				FIELD APPAREL	88001	9250	20.48
				FIELD APPAREL	88001	9250	17.50
				CHECK POOL 667012 TOTAL FOR FUND 250:			<u>189.53</u>
05/29/2024	POOL	667033*#	DEARBORN NATIONAL LIFE INSURANCE	LIFE AND AD&D PREMIUM	71900	9250	125.50
				DISABILITY PREMIUM	71900	9250	234.36
				LONG TERM DISABILITY PREMIUM	71900	9250	64.84
				CHECK POOL 667033 TOTAL FOR FUND 250:			<u>424.70</u>
05/29/2024	POOL	667046	CLARISSA CAYTON	REIMBURSEMENT	80147	9250	108.00

Check Date	Bank	Check #	Payee	Description	Account	Dept	Amount
Fund: 250 COMMUNICATIONS							
Department: 9250 COMMUNICATION EXPENDITURE							
05/29/2024	POOL	667098*#	ODP BUSINESS SOLUTIONS LLC	OFFICE SUPPLY	72700	9250	46.43
				OFFICE SUPPLY	72700	9250	110.67
				CHECK POOL 667098 TOTAL FOR FUND 250:			<u>157.10</u>
05/29/2024	POOL	667115	LAKESHORE JANITORIAL SPECIALIST	JANITORIAL SERVICES	80100	9250	1,494.00
05/29/2024	POOL	667152	GREAT LAKES MULTIMEDIA SUPPLY INC	CAMERA EQUIPMENT	98412	9250	2,070.00
				CAMERA EQUIPMENT	98412	9250	2,070.00
				CHECK POOL 667152 TOTAL FOR FUND 250:			<u>4,140.00</u>
				Total for department 9250:			15,309.12
				Total for fund 250 COMMUNICATIONS			15,309.12

Check Date	Bank	Check #	Payee	Description	Account	Dept	Amount
Fund: 259 INDIGENT DEFENSE FUND							
Department: 9259 INDIGENT DEFENSE EXPENDITURES							
05/29/2024	POOL	666849	WILLIAM BRANCH	COURT APPOINTED ATTORNEY	82601	9259	240.00
				COURT APPOINTED ATTORNEY	82601	9259	240.00
				CHECK POOL 666849 TOTAL FOR FUND 259:			<u>480.00</u>
05/29/2024	POOL	666859	KENNETH J WROBEL	COURT APPOINTED ATTORNEY	82601	9259	360.00
				COURT APPOINTED ATTORNEY	82601	9259	150.00
				CHECK POOL 666859 TOTAL FOR FUND 259:			<u>510.00</u>
05/29/2024	POOL	666885*#	DAWN M WALTON	COURT APPOINTED ATTORNEY	82601	9259	210.00
				COURT APPOINTED ATTORNEY	82601	9259	270.00
				COURT APPOINTED ATTORNEY	82601	9259	330.00
				COURT APPOINTED ATTORNEY	82601	9259	630.00
				COURT APPOINTED ATTORNEY	82601	9259	330.00
				COURT APPOINTED ATTORNEY	82601	9259	240.00
				COURT APPOINTED ATTORNEY	82601	9259	210.00
				CHECK POOL 666885 TOTAL FOR FUND 259:			<u>2,220.00</u>
05/29/2024	POOL	666897	DAVID WORDEN	COURT APPOINTED ATTORNEY	82601	9259	570.00
				COURT APPOINTED ATTORNEY	82601	9259	120.00
				CHECK POOL 666897 TOTAL FOR FUND 259:			<u>690.00</u>
05/29/2024	POOL	666899	ANDREW M CANU	COURT APPOINTED ATTORNEY	82601	9259	300.00
				COURT APPOINTED ATTORNEY	82601	9259	450.00
				COURT APPOINTED ATTORNEY	82601	9259	480.00
				COURT APPOINTED ATTORNEY	82601	9259	480.00
				COURT APPOINTED ATTORNEY	82601	9259	330.00
				CHECK POOL 666899 TOTAL FOR FUND 259:			<u>2,040.00</u>
05/29/2024	POOL	666912	MATTHEW A LICATA	COURT APPOINTED ATTORNEY	82601	9259	390.00
				COURT APPOINTED ATTORNEY	82601	9259	120.00
				COURT APPOINTED ATTORNEY	82601	9259	120.00
				COURT APPOINTED ATTORNEY	82601	9259	240.00
				COURT APPOINTED ATTORNEY	82601	9259	240.00
				COURT APPOINTED ATTORNEY	82601	9259	450.00
				CHECK POOL 666912 TOTAL FOR FUND 259:			<u>1,560.00</u>

Check Date	Bank	Check #	Payee	Description	Account	Dept	Amount
Fund: 259 INDIGENT DEFENSE FUND							
Department: 9259 INDIGENT DEFENSE EXPENDITURES							
05/29/2024	POOL	666915	PAUL SCALLY	COURT APPOINTED ATTORNEY	82601	9259	450.00
				COURT APPOINTED ATTORNEY	82601	9259	300.00
				CHECK POOL 666915 TOTAL FOR FUND 259:			<u>750.00</u>
05/29/2024	POOL	666920	JULIE A HLYWA	COURT APPOINTED ATTORNEY	82601	9259	450.00
05/29/2024	POOL	666924	JASON MALKIEWICZ	COURT APPOINTED ATTORNEY	82601	9259	600.00
				COURT APPOINTED ATTORNEY	82601	9259	330.00
				COURT APPOINTED ATTORNEY	82601	9259	180.00
				COURT APPOINTED ATTORNEY	82601	9259	180.00
				CHECK POOL 666924 TOTAL FOR FUND 259:			<u>1,290.00</u>
05/29/2024	POOL	666927	VINCENZO MANZELLA	COURT APPOINTED ATTORNEY	82601	9259	300.00
05/29/2024	POOL	666937	SUSAN R COLE	COURT APPOINTED ATTORNEY	82601	9259	150.00
				COURT APPOINTED ATTORNEY	82601	9259	150.00
				COURT APPOINTED ATTORNEY	82601	9259	150.00
				COURT APPOINTED ATTORNEY	82601	9259	270.00
				COURT APPOINTED ATTORNEY	82601	9259	120.00
				COURT APPOINTED ATTORNEY	82601	9259	210.00
				COURT APPOINTED ATTORNEY	82601	9259	420.00
				COURT APPOINTED ATTORNEY	82601	9259	120.00
				CHECK POOL 666937 TOTAL FOR FUND 259:			<u>1,590.00</u>
05/29/2024	POOL	666941	AVIS CHOULAGH LAW PLLC	COURT APPOINTED ATTORNEY	82601	9259	150.00
05/29/2024	POOL	666955	JAMES R HILLER	COURT APPOINTED ATTORNEY	82601	9259	175.00
				COURT APPOINTED ATTORNEY	82601	9259	330.00
				CHECK POOL 666955 TOTAL FOR FUND 259:			<u>505.00</u>
05/29/2024	POOL	666957	LARRY R KIPKE ATTORNEY AT	COURT APPOINTED ATTORNEY	82601	9259	960.00
				COURT APPOINTED ATTORNEY	82601	9259	360.00
				COURT APPOINTED ATTORNEY	82601	9259	300.00
				CHECK POOL 666957 TOTAL FOR FUND 259:			<u>1,620.00</u>
05/29/2024	POOL	666991	JENNA BOMMARITO CROSS	COURT APPOINTED ATTORNEY	82601	9259	125.00
				COURT APPOINTED ATTORNEY	82601	9259	210.00
				CHECK POOL 666991 TOTAL FOR FUND 259:			<u>335.00</u>

Check Date	Bank	Check #	Payee	Description	Account	Dept	Amount
Fund: 259 INDIGENT DEFENSE FUND							
Department: 9259 INDIGENT DEFENSE EXPENDITURES							
05/29/2024	POOL	666998	KIMBERLY DIBARTOLOMEO	COURT APPOINTED ATTORNEY	82601	9259	90.00
				COURT APPOINTED ATTORNEY	82601	9259	120.00
				CHECK POOL 666998 TOTAL FOR FUND 259:			<u>210.00</u>
05/29/2024	POOL	667015	DEBORAH WEIHERMULLER	COURT APPOINTED ATTORNEY	82601	9259	120.00
05/29/2024	POOL	667032	MARK VRANA	COURT APPOINTED ATTORNEY	82601	9259	540.00
				COURT APPOINTED ATTORNEY	82601	9259	390.00
				CHECK POOL 667032 TOTAL FOR FUND 259:			<u>930.00</u>
05/29/2024	POOL	667033*#	DEARBORN NATIONAL LIFE INSURANCE	LIFE AND AD&D PREMIUM	71900	9259	16.87
				DISABILITY PREMIUM	71900	9259	31.68
				LONG TERM DISABILITY PREMIUM	71900	9259	5.19
				CHECK POOL 667033 TOTAL FOR FUND 259:			<u>53.74</u>
05/29/2024	POOL	667037	ANGELO DONOFRIO	COURT APPOINTED ATTORNEY	82601	9259	150.00
05/29/2024	POOL	667040	MICHELLE LUNDQUIST	COURT APPOINTED ATTORNEY	82601	9259	120.00
				COURT APPOINTED ATTORNEY	82601	9259	360.00
				CHECK POOL 667040 TOTAL FOR FUND 259:			<u>480.00</u>
05/29/2024	POOL	667129	PERNICANO LAW PLLC	COURT APPOINTED ATTORNEY	82601	9259	150.00
				COURT APPOINTED ATTORNEY	82601	9259	975.00
				COURT APPOINTED ATTORNEY	82601	9259	570.00
				CHECK POOL 667129 TOTAL FOR FUND 259:			<u>1,695.00</u>
05/29/2024	POOL	667147	YVETTE BARRETT	COURT APPOINTED ATTORNEY	82601	9259	120.00
				COURT APPOINTED ATTORNEY	82601	9259	120.00
				COURT APPOINTED ATTORNEY	82601	9259	120.00
				COURT APPOINTED ATTORNEY	82601	9259	120.00
				CHECK POOL 667147 TOTAL FOR FUND 259:			<u>480.00</u>
05/29/2024	POOL	667150	ADRIANA ROSE PICCIRILLI	COURT APPOINTED ATTORNEY	82601	9259	270.00
05/29/2024	POOL	667154	SHAWN ABBASI	COURT APPOINTED ATTORNEY	82601	9259	100.00
05/29/2024	POOL	667157	NINA WARDA	COURT APPOINTED ATTORNEY	82601	9259	300.00
				COURT APPOINTED ATTORNEY	82601	9259	450.00

Check Date	Bank	Check #	Payee	Description	Account	Dept	Amount
Fund: 259 INDIGENT DEFENSE FUND							
Department: 9259 INDIGENT DEFENSE EXPENDITURES							
CHECK POOL 667157 TOTAL FOR FUND 259:							750.00
05/29/2024	POOL	667159	PAUL BUKOWSKI	COURT APPOINTED ATTORNEY	82601	9259	150.00
05/29/2024	POOL	667183	TINA M PERSHA MA LPC	SUBSTANCE ABUSE EVALUATION	80100	9259	300.00
05/29/2024	POOL	667184	TINA M PERSHA MA LPC	SUBSTANCE ABUSE EVALUATION	80100	9259	300.00
Total for department 9259:							20,478.74
Total for fund 259 INDIGENT DEFENSE FUND							20,478.74

05/22/2024 11:26 AM
User: tcameron
DB: Warren

CHECK DISBURSEMENT REPORT FOR CITY OF WARREN
CHECK NUMBER 666777 - 667227

Check Date	Bank	Check #	Payee	Description	Account	Dept	Amount
Fund: 261 DRUG FORFEITURE FUND							
Department: 9261 DRUG FORFEIT EXPENDITURES							
05/29/2024	POOL	666858*#	CANFIELD EQUIP SVC INC	UPFITTING CITY VEHICLES	82215	9261	21,903.48
05/29/2024	POOL	666884*#	PSP STORES LLC	CANINE UNIT SUPPLY	82215	9261	22.66
05/29/2024	POOL	666922	RAY ALLEN MANUFACTURING	CANINE SUPPLY	82215	9261	573.25
Total for department 9261:							22,499.39
Total for fund 261 DRUG FORFEITURE FUND							22,499.39

Check Date	Bank	Check #	Payee	Description	Account	Dept	Amount
Fund: 262 POLICE TRAINING FUND							
Department: 9262 POLICE TRAINING EXPEND							
05/29/2024	POOL	666950	CENTER MASS INC	TRAINING	86400	9262	1,978.00
05/29/2024	POOL	667223	MACOMB COMMUNITY COLLEGE	TRAINING	86400	9262	3,900.00
05/29/2024	POOL	667224	KIESLER POLICE SUPPLY INC	TRAINING SUPPLY	86400	9262	2,149.90
				TRAINING SUPPLY	86400	9262	525.90
				CHECK POOL 667224 TOTAL FOR FUND 262:			<u>2,675.80</u>
				Total for department 9262:			8,553.80
				Total for fund 262 POLICE TRAINING FUND			8,553.80

Check Date	Bank	Check #	Payee	Description	Account	Dept	Amount
Fund: 271 LIBRARY SPECIAL REVENUE							
Department: 0000							
05/29/2024	POOL	666828	SUBURBAN LIBRARY	MILLER VIDEO RECEIPTS	20271	0000	18.00
				BURNETTE VIDEO RECEIPTS	20272	0000	10.00
				BUSCH VIDEO RECEIPTS	20274	0000	11.00
				CHECK POOL 666828 TOTAL FOR FUND 271:			<u>39.00</u>
				Total for department 0000:			39.00
Department: 9271 LIBRARY EXPENDITURES							
05/09/2024	POOL	666778*#	DTE ENERGY	ELECTRIC SERVICE	92000	9271	845.81
05/09/2024	POOL	666781*#	WINDSTREAM COMMUNICATIONS INC	TELEPHONE SERVICE	85300	9271	9.83
				TELEPHONE SERVICE	85300	9271	42.55
				TELEPHONE SERVICE	85300	9271	26.01
				TELEPHONE SERVICE	85300	9271	200.69
				CHECK POOL 666781 TOTAL FOR FUND 271:			<u>279.08</u>
05/09/2024	POOL	666786*#	DENCAP	DENTAL PREMIUMS	71900	9271	57.00
05/16/2024	POOL	666788*#	DTE ENERGY	ELECTRIC SERVICE	92000	9271	793.56
05/16/2024	POOL	666790	AT&T	MONTHLY PHONE SERVICE	85300	9271	156.18
05/29/2024	POOL	666811	DEMCO INC	PROCESSING SUPPLY	72700	9271	309.67
05/29/2024	POOL	666835*#	CITY OF WARREN	WATER SERVICE	92000	9271	122.24
				WATER SERVICE	92000	9271	122.24
				WATER SERVICE	92000	9271	12.40
				WATER SERVICE	92000	9271	133.44
				WATER SERVICE	92000	9271	41.92
				WATER SERVICE	92000	9271	262.16
				CHECK POOL 666835 TOTAL FOR FUND 271:			<u>694.40</u>
05/29/2024	POOL	666861	BRODART COMPANY	PROCESSING SUPPLY	72700	9271	980.98
05/29/2024	POOL	666882	THE LIBRARY STORE INC	OPERATING SUPPLY	72700	9271	1,454.86
05/29/2024	POOL	666886*#	HOME DEPOT CREDIT SERVICE	MAINTENANCE SUPPLY	93000	9271	159.00
05/29/2024	POOL	666901	LYNN BIESZKA	TRAVEL EXPENSE	86400	9271	1,600.00

05/22/2024 11:26 AM
 User: tcameron
 DB: Warren

CHECK DISBURSEMENT REPORT FOR CITY OF WARREN
 CHECK NUMBER 666777 - 667227

Check Date	Bank	Check #	Payee	Description	Account	Dept	Amount
Fund: 271 LIBRARY SPECIAL REVENUE							
Department: 9271 LIBRARY EXPENDITURES							
05/29/2024	POOL	666911*#	ULINE INC	LIBRARY SUPPLY	72700	9271	200.44
05/29/2024	POOL	666954	TOSHIBA BUSINESS SOLUTIONS	OFFICE SUPPLY	72702	9271	1,385.35
05/29/2024	POOL	666964	SUBURBAN LIBRARY CO-OP	ENVISIONWARE ANNUAL MAINTENANCE	80117	9271	2,200.83
05/29/2024	POOL	666971	UNIQUE MANAGEMENT	COLLECTION SERVICES	80100	9271	52.00
				COLLECTION SERVICES	80100	9271	360.50
				CHECK POOL 666971 TOTAL FOR FUND 271:			<u>412.50</u>
05/29/2024	POOL	666986*#	APPLIED INNOVATION	COPIER MAINTENANCE	72702	9271	20.38
				COPIER MAINTENANCE	72702	9271	61.48
				CHECK POOL 666986 TOTAL FOR FUND 271:			<u>81.86</u>
05/29/2024	POOL	667028	T-MOBILE USA INC	MOBILE HOT SPOT SERVICE	80100	9271	827.05
05/29/2024	POOL	667033*#	DEARBORN NATIONAL LIFE INSURANCE	LIFE AND AD&D PREMIUM	71900	9271	459.39
				DISABILITY PREMIUM	71900	9271	858.69
				LONG TERM DISABILITY PREMIUM	71900	9271	208.12
				CHECK POOL 667033 TOTAL FOR FUND 271:			<u>1,526.20</u>
05/29/2024	POOL	667043	AVENTRIC TECHNOLOGIES	EQUIPMENT SUPPLY	72700	9271	213.00
				EQUIPMENT SUPPLY	72700	9271	213.00
				EQUIPMENT SUPPLY	72700	9271	54.00
				EQUIPMENT SUPPLY	72700	9271	159.00
				CHECK POOL 667043 TOTAL FOR FUND 271:			<u>639.00</u>
				Total for department 9271:			14,603.77
				Total for fund 271 LIBRARY SPECIAL REVENUE			14,642.77

Check Date	Bank	Check #	Payee	Description	Account	Dept	Amount
Fund: 273 CDBG ENTITLEMENT FUND							
Department: 9666 ADMINISTRATIVE COSTS							
05/29/2024	POOL	666986*#	APPLIED INNOVATION	COPIER MAINTENANCE	95000	9666	59.63
05/29/2024	POOL	667007*#	21ST CENTURY MEDIA NEWSPAPER LLC	PUBLIC NOTICE	95000	9666	543.50
05/29/2024	POOL	667033*#	DEARBORN NATIONAL LIFE INSURANCE	LIFE AND AD&D PREMIUM	71900	9666	57.42
				DISABILITY PREMIUM	71900	9666	107.48
				LONG TERM DISABILITY PREMIUM	71900	9666	36.59
				CHECK POOL 667033 TOTAL FOR FUND 273:			<u>201.49</u>
05/29/2024	POOL	667098*#	ODP BUSINESS SOLUTIONS LLC	OFFICE SUPPLY	95000	9666	159.93
				OFFICE SUPPLY	95000	9666	11.87
				OFFICE SUPPLY	95000	9666	9.59
				CHECK POOL 667098 TOTAL FOR FUND 273:			<u>181.39</u>
				Total for department 9666:			986.01
Department: 9706 RESID REHAB DELIVERY							
05/29/2024	POOL	666846*#	MACOMB COUNTY REGISTER	RECORDING FEES	80134	9706	210.00
05/29/2024	POOL	666876	ETITLE AGENCY INC	TITLE SEARCHES	80134	9706	125.00
				TITLE SEARCHES	80134	9706	125.00
				TITLE SEARCHES	80134	9706	125.00
				TITLE SEARCHES	80134	9706	125.00
				TITLE SEARCHES	80134	9706	125.00
				CHECK POOL 666876 TOTAL FOR FUND 273:			<u>625.00</u>
05/29/2024	POOL	666930*	MJ ENVIRONMENTAL INC	LEAD INSPECTIONS/CLEARANCES	80134	9706	475.00
				LEAD INSPECTIONS/CLEARANCES	80134	9706	475.00
				CHECK POOL 666930 TOTAL FOR FUND 273:			<u>950.00</u>
05/29/2024	POOL	666989	ROBERT WEIDNER	REIMBURSEMENT	80134	9706	30.00
05/29/2024	POOL	667033*#	DEARBORN NATIONAL LIFE INSURANCE	LIFE AND AD&D PREMIUM	71900	9706	23.09
				DISABILITY PREMIUM	71900	9706	43.18
				LONG TERM DISABILITY PREMIUM	71900	9706	12.04
				CHECK POOL 667033 TOTAL FOR FUND 273:			<u>78.31</u>
				Total for department 9706:			1,893.31

Check Date	Bank	Check #	Payee	Description	Account	Dept	Amount
Fund: 273 CDBG ENTITLEMENT FUND							
Department: 9707 RESID REHAB PROJECTS							
05/29/2024	POOL	667071	QUALIFIED CONSTRUCTION CORPORATION	REHAB PROJECT COSTS	88102	9707	2,703.20
Total for department 9707:							2,703.20
Department: 9850 UNALLOCATED EXPENSES							
05/29/2024	POOL	667145	HEARTS FOR HOMES INC	HOMLESS PREVENTION SERVICES	80199	9850	5,576.90
Total for department 9850:							5,576.90
Total for fund 273 CDBG ENTITLEMENT FUND							11,159.42

Check Date	Bank	Check #	Payee	Description	Account	Dept	Amount
Fund: 277 H.O.M.E.							
Department: 9777 PROGRAM ADMINISTRATION							
05/29/2024	POOL	666846*#	MACOMB COUNTY REGISTER	RECORDING FEES	88102	9777	60.00
05/29/2024	POOL	667007*#	21ST CENTURY MEDIA NEWSPAPER LLC	PUBLIC NOTICE	88102	9777	543.50
				Total for department 9777:			603.50
				Total for fund 277 H.O.M.E.			603.50

Check Date	Bank	Check #	Payee	Description	Account	Dept	Amount
Fund: 278 HOUSING OPPORTUNITIES							
Department: 9778 HOUSING OPPORTUNITIES EXP							
05/29/2024	POOL	666932	JAMES R WOLFE	RENTAL ASSISTANCE	80237	9778	652.00
05/29/2024	POOL	666944	COUNTRY COURT APARTMENTS	RENTAL ASSISTANCE	80237	9778	555.00
				RENTAL ASSISTANCE	80237	9778	636.00
				CHECK POOL 666944 TOTAL FOR FUND 278:			<u>1,191.00</u>
05/29/2024	POOL	666951	ROYAL HILL APARTMENTS INC	RENTAL ASSISTANCE	80237	9778	392.00
05/29/2024	POOL	666970	BULLOCK ENTERPRISES LLC	RENTAL ASSISTANCE	80237	9778	703.00
				RENTAL ASSISTANCE	80237	9778	803.00
				CHECK POOL 666970 TOTAL FOR FUND 278:			<u>1,506.00</u>
05/29/2024	POOL	666972	RICHTER & ASSOCIATES INC	RENTAL ASSISTANCE	80237	9778	728.00
05/29/2024	POOL	666983	IAN WEAVER	RENTAL ASSISTANCE	80237	9778	890.00
				RENTAL ASSISTANCE	80237	9778	1,111.00
				CHECK POOL 666983 TOTAL FOR FUND 278:			<u>2,001.00</u>
05/29/2024	POOL	666987	NEW FRONTIER 21 LLC	RENTAL ASSISTANCE	80237	9778	1,089.00
05/29/2024	POOL	666990	TG WARREN INC	RENTAL ASSISTANCE	80237	9778	695.00
05/29/2024	POOL	667052	GABBARA PROPERTY MANAGEMENT, LLC	RENTAL ASSISTANCE	80237	9778	1,200.00
				RENTAL ASSISTANCE	80237	9778	1,400.00
				RENTAL ASSISTANCE	80237	9778	697.00
				CHECK POOL 667052 TOTAL FOR FUND 278:			<u>3,297.00</u>
05/29/2024	POOL	667058	ELLIOTT PROPERTIES LTD LLC	RENTAL ASSISTANCE	80237	9778	557.00
05/29/2024	POOL	667061	TROY A VAN GAMPELAERE	RENTAL ASSISTANCE	80237	9778	614.00
05/29/2024	POOL	667068	AUBURN HILLS LIMITED DIVIDEND	RENTAL ASSISTANCE	80237	9778	426.00
05/29/2024	POOL	667072	DELANO LORD BOWMAN SR	RENTAL ASSISTANCE	80237	9778	1,510.00
05/29/2024	POOL	667083	PREZZCO INVESTMENTS	RENTAL ASSISTANCE	80237	9778	586.00
05/29/2024	POOL	667090	FOX POINTE MS LLC	RENTAL ASSISTANCE	80237	9778	30.00
05/29/2024	POOL	667091	LENOX PROPERTY MANAGEMENT	RENTAL ASSISTANCE	80237	9778	1,350.00
05/29/2024	POOL	667095	JOMANDALETH LLC	RENTAL ASSISTANCE	80237	9778	576.00
05/29/2024	POOL	667102	MACOMB COUNTY HOUSING & RENTALS	RENTAL ASSISTANCE	80237	9778	1,186.00

Check Date	Bank	Check #	Payee	Description	Account	Dept	Amount
Fund: 278 HOUSING OPPORTUNITIES							
Department: 9778 HOUSING OPPORTUNITIES EXP							
				RENTAL ASSISTANCE	80237	9778	1,674.00
				CHECK POOL 667102 TOTAL FOR FUND 278:			<u>2,860.00</u>
05/29/2024	POOL	667104	KASSEM ZAHER	RENTAL ASSISTANCE	80237	9778	1,100.00
05/29/2024	POOL	667105	AUBURN HILLS PROPERTY SERVICES LLC	RENTAL ASSISTANCE	80237	9778	900.00
05/29/2024	POOL	667107	HALLAC PROPERTY MANAGEMENT LLC	RENTAL ASSISTANCE	80237	9778	453.00
				RENTAL ASSISTANCE	80237	9778	1,046.00
				RENTAL ASSISTANCE	80237	9778	523.00
				CHECK POOL 667107 TOTAL FOR FUND 278:			<u>2,022.00</u>
05/29/2024	POOL	667111	MICHAEL J HENDRICKSON	RENTAL ASSISTANCE	80237	9778	862.00
05/29/2024	POOL	667114	AG MANAGEMENT CO LLC	RENTAL ASSISTANCE	80237	9778	950.00
05/29/2024	POOL	667116	FORTE APARTMENT MANAGEMENT LLC	RENTAL ASSISTANCE	80237	9778	498.00
05/29/2024	POOL	667118	KFH LLC	RENTAL ASSISTANCE	80237	9778	690.00
05/29/2024	POOL	667121	FRASER POINTE MANOR APARTMENTS	RENTAL ASSSISTANCE	80237	9778	869.00
05/29/2024	POOL	667132	BDP CC LLC	RENTAL ASSISTANCE	80237	9778	661.00
05/29/2024	POOL	667133	GREAT LAKES PROPERTY MGMT CO LLC	RENTAL ASSISTANCE	80237	9778	646.00
05/29/2024	POOL	667134	HP LIMITED DIVIDEND HOUSING	RENTAL ASSISTANCE	80237	9778	944.00
05/29/2024	POOL	667135	REE LLC	RENTAL ASSISTANCE	80237	9778	1,100.00
05/29/2024	POOL	667136	HEIGHTS OF SOUTHFIELD LLC	RENTAL ASSISTANCE	80237	9778	622.00
				RENTAL ASSISTANCE	80237	9778	1,035.00
				RENTAL ASSISTANCE	80237	9778	849.00
				CHECK POOL 667136 TOTAL FOR FUND 278:			<u>2,506.00</u>
05/29/2024	POOL	667137	MIMG XLIII WARREN CLUB, LLC	RENTAL ASSISTANCE	80237	9778	975.00
05/29/2024	POOL	667140	GEORGE TATARYN	RENTAL ASSISTANCE	80237	9778	1,023.00
05/29/2024	POOL	667141	MD H RAHMAN	RENTAL ASSISTANCE	80237	9778	767.00
05/29/2024	POOL	667142	ATN HOME TECHNOLOGY LLC	RENTAL ASSISTANCE	80237	9778	984.00
05/29/2024	POOL	667148	LYNN FRANCIS	RENTAL ASSISTANCE	80237	9778	232.00
05/29/2024	POOL	667149	LAFAYETTE PLACE LOFTS LLC	RENTAL ASSISTANCE	80237	9778	267.00
05/29/2024	POOL	667162	DOLORES A HAYNES	RENTAL ASSISTANCE	80237	9778	1,100.00
05/29/2024	POOL	667166	GANESH REALTY LLC	RENTAL ASSISTANCE	80237	9778	584.00

Check Date	Bank	Check #	Payee	Description	Account	Dept	Amount
Fund: 278 HOUSING OPPORTUNITIES							
Department: 9778 HOUSING OPPORTUNITIES EXP							
05/29/2024	POOL	667167	VICTORIA YASKANIN	RENTAL ASSISTANCE	80237	9778	1,676.00
05/29/2024	POOL	667168	WHITE LAKE RESIDENCE LLC	RENTAL ASSISTANCE	80237	9778	827.00
Total for department 9778:							42,243.00
Total for fund 278 HOUSING OPPORTUNITIES							42,243.00

Check Date	Bank	Check #	Payee	Description	Account	Dept	Amount
Fund: 281 LEAD HAZARD CONTROL GRANT							
Department: 9706 RESID REHAB DELIVERY							
05/29/2024	POOL	666930*	MJ ENVIRONMENTAL INC	LEAD INSPECTIONS/CLEARANCES	80179	9706	475.00
				LEAD INSPECTIONS/CLEARANCES	80179	9706	475.00
				LEAD INSPECTIONS/CLEARANCES	80179	9706	275.00
				LEAD INSPECTIONS/CLEARANCES	80179	9706	275.00
				LEAD INSPECTIONS/CLEARANCES	80179	9706	475.00
				LEAD INSPECTIONS/CLEARANCES	80179	9706	475.00
				CHECK POOL 666930 TOTAL FOR FUND 281:			<u>2,450.00</u>
				Total for department 9706:			2,450.00
				Total for fund 281 LEAD HAZARD CONTROL GRANT			2,450.00

Check Date	Bank	Check #	Payee	Description	Account	Dept	Amount
Fund: 410 37TH D.C. BLDG RENOVATION							
Department: 9410 COURT BLDG RENOVATION EXP							
05/29/2024	POOL	667035	LIQUID WEB LLC	ONBASE SERVER SERVICES	97400	9410	2,244.00
05/29/2024	POOL	667088	DMC TECHNOLOGY GROUP INC	DASCOM PRINTER	97400	9410	890.00
				DASCOM PRINTER	97400	9410	80.00
				CHECK POOL 667088 TOTAL FOR FUND 410:			970.00
				Total for department 9410:			3,214.00
				Total for fund 410 37TH D.C. BLDG RENOVATION			3,214.00

Check Date	Bank	Check #	Payee	Description	Account	Dept	Amount
Fund: 494 DDA ADMINISTRATION FUND							
Department: 9494 DDA ADMIN EXPENDITURES							
05/09/2024	POOL	666781*#	WINDSTREAM COMMUNICATIONS INC	TELEPHONE SERVICE	85300	9494	6.55
				TELEPHONE SERVICE	85300	9494	17.34
				CHECK POOL 666781 TOTAL FOR FUND 494:			<u>23.89</u>
05/09/2024	POOL	666786*#	DENCAP	DENTAL PREMIUMS	71900	9494	57.00
05/29/2024	POOL	667033*#	DEARBORN NATIONAL LIFE INSURANCE	LIFE AND AD&D PREMIUM	71900	9494	52.69
				DISABILITY PREMIUM	71900	9494	98.33
				LONG TERM DISABILITY PREMIUM	71900	9494	27.42
				CHECK POOL 667033 TOTAL FOR FUND 494:			<u>178.44</u>
				Total for department 9494:			259.33
				Total for fund 494 DDA ADMINISTRATION FUND			259.33

05/22/2024 11:26 AM
 User: tcameron
 DB: Warren

CHECK DISBURSEMENT REPORT FOR CITY OF WARREN
 CHECK NUMBER 666777 - 667227

Check Date	Bank	Check #	Payee	Description	Account	Dept	Amount
Fund: 536 SENIOR HOUSING - STILWELL							
Department: 9536 STILWELL MANOR EXPENSES							
05/09/2024	POOL	666786*#	DENCAP	DENTAL PREMIUMS	71900	9536	57.00
05/16/2024	POOL	666792*#	VERIZON WIRELESS	CELLULAR SERVICE	85300	9536	40.51
05/29/2024	POOL	666835*#	CITY OF WARREN	WATER SERVICE	92000	9536	4,123.19
				WATER SERVICE	92000	9536	21.57
				CHECK POOL 666835 TOTAL FOR FUND 536:			<u>4,144.76</u>
05/29/2024	POOL	666893*#	GORDON FOOD SERVICE INC	PARTY SUPPLY	76001	9536	73.07
05/29/2024	POOL	666946*#	LANDSCAPE SERVICE INC	MOWING/FERTILIZATION	80100	9536	345.00
05/29/2024	POOL	666967*#	D/A CENTRAL INC	SECURITY CAMERA UPGRADES	98408	9536	21,560.54
05/29/2024	POOL	667033*#	DEARBORN NATIONAL LIFE INSURANCE	LIFE AND AD&D PREMIUM	71900	9536	108.93
				DISABILITY PREMIUM	71900	9536	203.29
				LONG TERM DISABILITY PREMIUM	71900	9536	56.70
				CHECK POOL 667033 TOTAL FOR FUND 536:			<u>368.92</u>
05/29/2024	POOL	667084*#	SKIP PRINTING COMPANY	OFFICE SUPPLIES	72700	9536	96.25
05/29/2024	POOL	667098*#	ODP BUSINESS SOLUTIONS LLC	OFFICE SUPPLY	72700	9536	2.69
				Total for department 9536:			26,688.74
				Total for fund 536 SENIOR HOUSING - STILWELL			26,688.74

Check Date	Bank	Check #	Payee	Description	Account	Dept	Amount
Fund: 537 SENIOR HOUSING-JOS. COACH							
Department: 0000							
05/29/2024	POOL	667214#	ESTATE OF LYDIA GRILLO	SECURITY DEPOSIT REFUND	28500	0000	812.00
Total for department 0000:							812.00
Department: 0080 REVENUES							
05/29/2024	POOL	667214#	ESTATE OF LYDIA GRILLO	SECURITY DEPOSIT REFUND	66704	0080	158.00
				SECURITY DEPOSIT REFUND	67900	0080	(675.00)
CHECK POOL 667214 TOTAL FOR FUND 537:							<u>(517.00)</u>
Total for department 0080:							(517.00)
Department: 9537 JOS COACH MANOR EXPENSES							
05/09/2024	POOL	666777	CONSUMERS ENERGY	UTILITY SERVICE	92000	9537	13.98
				UTILITY SERVICE	92000	9537	23.62
				UTILITY SERVICE	92000	9537	13.64
				UTILITY SERVICE	92000	9537	16.09
				UTILITY SERVICE	92000	9537	21.04
				UTILITY SERVICE	92000	9537	19.30
				UTILITY SERVICE	92000	9537	24.48
				UTILITY SERVICE	92000	9537	22.74
				UTILITY SERVICE	92000	9537	10.61
CHECK POOL 666777 TOTAL FOR FUND 537:							<u>165.50</u>
05/09/2024	POOL	666781*#	WINDSTREAM COMMUNICATIONS INC	TELEPHONE SERVICE	85300	9537	207.82
				TELEPHONE SERVICE	85300	9537	197.65
				TELEPHONE SERVICE	85300	9537	221.86
CHECK POOL 666781 TOTAL FOR FUND 537:							<u>627.33</u>
05/09/2024	POOL	666786*#	DENCAP	DENTAL PREMIUMS	71900	9537	114.00
05/21/2024	POOL	666805	DTE ENERGY	ELECTRIC SERVICE	92000	9537	6,072.76
				ELECTRIC SERVICE	92000	9537	1,713.39
				ELECTRIC SERVICE	92000	9537	5,393.33
				ELECTRIC SERVICE	92000	9537	6,291.72
CHECK POOL 666805 TOTAL FOR FUND 537:							<u>19,471.20</u>
05/29/2024	POOL	666835*#	CITY OF WARREN	WATER SERVICE	92000	9537	1,451.00
				WATER SERVICE	92000	9537	2,361.42
				WATER SERVICE	92000	9537	2,361.42

05/22/2024 11:26 AM
 User: tcameron
 DB: Warren

CHECK DISBURSEMENT REPORT FOR CITY OF WARREN
 CHECK NUMBER 666777 - 667227

Check Date	Bank	Check #	Payee	Description	Account	Dept	Amount
Fund: 537 SENIOR HOUSING-JOS. COACH							
Department: 9537 JOS COACH MANOR EXPENSES							
				CHECK POOL 666835 TOTAL FOR FUND 537:			6,173.84
05/29/2024	POOL	666893*#	GORDON FOOD SERVICE INC	PARTY SUPPLY	76001	9537	219.22
05/29/2024	POOL	666929	OTIS ELEVATOR COMPANY	ELEVATOR MAINTENANCE	80100	9537	4,725.00
05/29/2024	POOL	666958	APCO SUPPLY	HOT WATER TANKS	77600	9537	2,660.00
05/29/2024	POOL	666967*#	D/A CENTRAL INC	SECURITY CAMERA UPGRADES	98408	9537	55,441.40
05/29/2024	POOL	666976	GRIFFIN PEST SOLUTIONS INC	PEST CONTROL SERVICE	80100	9537	1,645.00
				PEST CONTROL SERVICE	80100	9537	154.00
				PEST CONTROL SERVICE	80100	9537	270.00
				CHECK POOL 666976 TOTAL FOR FUND 537:			2,069.00
05/29/2024	POOL	667033*#	DEARBORN NATIONAL LIFE INSURANCE	LIFE AND AD&D PREMIUM	71900	9537	38.48
				DISABILITY PREMIUM	71900	9537	71.84
				LONG TERM DISABILITY PREMIUM	71900	9537	19.72
				CHECK POOL 667033 TOTAL FOR FUND 537:			130.04
05/29/2024	POOL	667084*#	SKIP PRINTING COMPANY	OFFICE SUPPLIES	72700	9537	288.75
05/29/2024	POOL	667098*#	ODP BUSINESS SOLUTIONS LLC	OFFICE SUPPLY	72700	9537	10.80
05/29/2024	POOL	667227	SCI FLOOR COVERING INC	CARPET INSTALLATION	80100	9537	200.00
				Total for department 9537:			92,296.08
				Total for fund 537 SENIOR HOUSING-JOS. COACH			92,591.08

Check Date	Bank	Check #	Payee	Description	Account	Dept	Amount
Fund: 592 WATER & SEWER SYSTEM FUND							
Department: 0000							
05/29/2024	POOL	666816	EJ USA INC	HYDRANT SUPPLY/PARTS	11000	0000	1,867.60
				HYDRANT SUPPLY/PARTS	11000	0000	234.69
				HYDRANT SUPPLY/PARTS	11000	0000	184.55
				CHECK POOL 666816 TOTAL FOR FUND 592:			<u>2,286.84</u>
05/29/2024	POOL	666817	ETNA SUPPLY COMPANY	COPPER SUPPLY PARTS	11100	0000	3,792.00
				REPAIR CLAMPS/SLEEVES	11100	0000	3,534.60
				CHECK POOL 666817 TOTAL FOR FUND 592:			<u>7,326.60</u>
05/29/2024	POOL	666820*#	FLORENCE CEMENT CO	WATER MAIN AND PAVEMENT RECONSTRUCTION	21000	0000	(139,175.77)
				WATER MAIN AND PAVEMENT RECONSTRUCTION	21001	0000	(13,917.58)
				WATER MAIN AND PAVEMENT RECONSTRUCTION	21132	0000	139,175.77
				CHECK POOL 666820 TOTAL FOR FUND 592:			<u>(13,917.58)</u>
05/29/2024	POOL	666844	AIELLI CONSTRUCTION CO	WATER MAIN REPLACEMENT	21001	0000	43,211.66
05/29/2024	POOL	666873#	DVM UTILITIES INC	SANITARY SEWER LINING	21000	0000	(216,091.40)
				SANITARY SEWER LINING	21001	0000	(21,609.14)
				SANITARY SEWER LINING	21127	0000	216,091.40
				CHECK POOL 666873 TOTAL FOR FUND 592:			<u>(21,609.14)</u>
05/29/2024	POOL	667044*#	MARK ANTHONY CONTRACTING INC	ROAD CONSTRUCTION AND WATER MAIN	21000	0000	(47,917.14)
				ROAD CONSTRUCTION AND WATER MAIN	21001	0000	(4,791.72)
				ROAD CONSTRUCTION AND WATER MAIN	21122	0000	47,917.14
				CHECK POOL 667044 TOTAL FOR FUND 592:			<u>(4,791.72)</u>
05/29/2024	POOL	667075#	COMMERCIAL CONTRACTING CORPORATION	DETENTION BASIN	21000	0000	(376,295.33)
				DETENTION BASIN	21024	0000	376,295.33
				CHECK POOL 667075 TOTAL FOR FUND 592:			<u>0.00</u>
05/29/2024	POOL	667209	FORREST CRYDERMAN	REFUND	04101	0000	96.42
05/29/2024	POOL	667210	SFR3 LLC	REFUND	04101	0000	61.11
05/29/2024	POOL	667217	KAREN DAY	REFUND	04101	0000	15.99
05/29/2024	POOL	667218*#	FERGUSON WATERWORKS	WATER/SEWER SUPPLY PARTS	11100	0000	689.77
				WATER/SEWER SUPPLY PARTS	11100	0000	3,680.76

Check Date	Bank	Check #	Payee	Description	Account	Dept	Amount
Fund: 592 WATER & SEWER SYSTEM FUND							
Department: 0000							
				WATER/SEWER SUPPLY PARTS	11100	0000	429.53
				WATER/SEWER SUPPLY PARTS	11100	0000	488.60
				WATER/SEWER SUPPLY PARTS	11100	0000	1,560.00
				CHECK POOL 667218 TOTAL FOR FUND 592:			<u>6,848.66</u>
				Total for department 0000:			19,528.84
Department: 1540 WATER MAINTENANCE							
05/09/2024	POOL	666778*#	DTE ENERGY	ELECTRIC SERVICE	92000	1540	547.27
05/09/2024	POOL	666781*#	WINDSTREAM COMMUNICATIONS INC	TELEPHONE SERVICE	85300	1540	767.43
05/09/2024	POOL	666784	THOMAS VANDEPUTTE	REIMBURSEMENT	74000	1540	23.48
05/16/2024	POOL	666788*#	DTE ENERGY	ELECTRIC SERVICE	92000	1540	138.03
				ELECTRIC SERVICE	92000	1540	74.29
				CHECK POOL 666788 TOTAL FOR FUND 592:			<u>212.32</u>
05/29/2024	POOL	666814*#	OCCUPATIONAL HEALTH CENTERS	MEDICAL SERVICE	74000	1540	85.00
				MEDICAL SERVICE	74000	1540	85.00
				CHECK POOL 666814 TOTAL FOR FUND 592:			<u>170.00</u>
05/29/2024	POOL	666821*#	GRAINGER INC	MAINTENANCE SUPPLY	74000	1540	449.34
				MAINTENANCE SUPPLY	74000	1540	48.46
				MAINTENANCE SUPPLY	74000	1540	54.16
				CHECK POOL 666821 TOTAL FOR FUND 592:			<u>551.96</u>
05/29/2024	POOL	666826	KUSH PAINT COMPANY	OPERATING SUPPLY	74000	1540	456.50
05/29/2024	POOL	666835*#	CITY OF WARREN	WATER SERVICE	92000	1540	428.46
				WATER SERVICE	92000	1540	21.57
				CHECK POOL 666835 TOTAL FOR FUND 592:			<u>450.03</u>
05/29/2024	POOL	666840*#	WHOLESALE TOOL CO	OPERATING SUPPLY	74000	1540	24.10
05/29/2024	POOL	666841	ZEP MANUFACTURING COMPANY	JANITORIAL SUPPLY	74000	1540	762.51
05/29/2024	POOL	666869#	MAURER'S TEXTILE RENTAL	FACILITY MAINTENANCE	97500	1540	45.27
				FACILITY MAINTENANCE	97500	1540	45.27

Check Date	Bank	Check #	Payee	Description	Account	Dept	Amount
Fund: 592 WATER & SEWER SYSTEM FUND							
Department: 1540 WATER MAINTENANCE							
CHECK POOL 666869 TOTAL FOR FUND 592:							90.54
05/29/2024	POOL	666886*#	HOME DEPOT CREDIT SERVICE	OPERATING SUPPLIES	74000	1540	574.29
05/29/2024	POOL	666889	AJAX MATERIALS CORPORATION	BITUMINOUS PATCHING MATERIAL	74000	1540	6,868.80
05/29/2024	POOL	666896	CONTRACTORS CONNECTION	OPERATING SUPPLY	74000	1540	89.80
05/29/2024	POOL	666919*#	CINTAS FIRST AID & SAFETY	FIRST AID SUPPLY	74000	1540	177.64
05/29/2024	POOL	666974	MICRO CENTER	MOBILE ACCESSORIES	74000	1540	659.97
				MOBILE ACCESSORIES	74000	1540	112.97
CHECK POOL 666974 TOTAL FOR FUND 592:							772.94
05/29/2024	POOL	666986*#	APPLIED INNOVATION	COPIER MAINTENANCE	74000	1540	10.00
05/29/2024	POOL	666995	MTECH COMPANY	OPERATING SUPPLIES	74000	1540	1,123.37
				OPERATING SUPPLIES	74000	1540	597.26
CHECK POOL 666995 TOTAL FOR FUND 592:							1,720.63
05/29/2024	POOL	667022*#	OSBURN INDUSTRIES INC	SAND SLAG & AGGREGATE	74000	1540	3,999.06
				SAND SLAG & AGGREGATE	74000	1540	1,419.08
CHECK POOL 667022 TOTAL FOR FUND 592:							5,418.14
05/29/2024	POOL	667033*#	DEARBORN NATIONAL LIFE INSURANCE	LIFE AND AD&D PREMIUM	71900	1540	649.72
				DISABILITY PREMIUM	71900	1540	1,215.39
				LONG TERM DISABILITY PREMIUM	71900	1540	296.91
CHECK POOL 667033 TOTAL FOR FUND 592:							2,162.02
05/29/2024	POOL	667051	S A TORELLO INC	CLASS II FILL SAND	74000	1540	333.27
				CLASS II FILL SAND	74000	1540	1,287.77
				CLASS II FILL SAND	74000	1540	501.52
CHECK POOL 667051 TOTAL FOR FUND 592:							2,122.56
05/29/2024	POOL	667054*#	AMERICAN PEST CONTROL INC	PEST CONTROL SERVICES	80100	1540	28.00
				PEST CONTROL SERVICES	80100	1540	28.00

Check Date	Bank	Check #	Payee	Description	Account	Dept	Amount
Fund: 592 WATER & SEWER SYSTEM FUND							
Department: 1540 WATER MAINTENANCE							
				CHECK POOL 667054 TOTAL FOR FUND 592:			56.00
05/29/2024	POOL	667070	VIC BOND SALES INC	OPERATING SUPPLY	74000	1540	1,385.50
05/29/2024	POOL	667089	LINDE GAS & EQUIPMENT INC	OPERATING SUPPLY	74000	1540	113.26
				OPERATING SUPPLY	74000	1540	121.06
				CHECK POOL 667089 TOTAL FOR FUND 592:			<u>234.32</u>
05/29/2024	POOL	667098*#	ODP BUSINESS SOLUTIONS LLC	OFFICE SUPPLY	74000	1540	49.97
				OFFICE SUPPLY	74000	1540	279.99
				OFFICE SUPPLY	74000	1540	23.99
				CHECK POOL 667098 TOTAL FOR FUND 592:			<u>353.95</u>
05/29/2024	POOL	667113*#	BMW KAR WASH LLC	CAR WASH	74000	1540	57.00
05/29/2024	POOL	667120#	USABLUBOOK	MISC SUPPLIES	74000	1540	341.70
05/29/2024	POOL	667146	SANTORO SERVICES LLC	SPOILS REMOVAL	80250	1540	24,450.00
05/29/2024	POOL	667155	ACLARA TECHNOLOGIES LLC	OPERATING SUPPLY	74000	1540	5,854.50
				Total for department 1540:			56,705.93
Department: 1560 ADMINISTRATION							
05/09/2024	POOL	666778*#	DTE ENERGY	ELECTRIC SERVICE	92000	1560	43.42
05/09/2024	POOL	666781*#	WINDSTREAM COMMUNICATIONS INC	TELEPHONE SERVICE	85300	1560	16.38
				TELEPHONE SERVICE	85300	1560	43.35
				CHECK POOL 666781 TOTAL FOR FUND 592:			<u>59.73</u>
05/09/2024	POOL	666783*#	POINT & PAY	FEB24 PROCESSING FEES	80100	1560	2,596.50
05/09/2024	POOL	666786*#	DENCAP	DENTAL PREMIUMS	71900	1560	57.00
05/16/2024	POOL	666788*#	DTE ENERGY	ELECTRIC SERVICE	92000	1560	24.08
05/16/2024	POOL	666792*#	VERIZON WIRELESS	CELLULAR SERVICE	85300	1560	288.53
				CELLULAR SERVICE	85300	1560	36.01
				CHECK POOL 666792 TOTAL FOR FUND 592:			<u>324.54</u>

Check Date	Bank	Check #	Payee	Description	Account	Dept	Amount
Fund: 592 WATER & SEWER SYSTEM FUND							
Department: 1560 ADMINISTRATION							
05/29/2024	POOL	666810*#	C & G PUBLISHING INC	PUBLIC NOTICE AD	80100	1560	82.50
05/29/2024	POOL	666982*#	GREAT LAKES GRAPHICS INC	WATER BILL POSTAGE	80200	1560	24,500.00
05/29/2024	POOL	666986*#	APPLIED INNOVATION	COPIER MAINTENANCE	74000	1560	81.96
05/29/2024	POOL	667033*#	DEARBORN NATIONAL LIFE INSURANCE	LIFE AND AD&D PREMIUM	71900	1560	358.46
				DISABILITY PREMIUM	71900	1560	669.46
				LONG TERM DISABILITY PREMIUM	71900	1560	174.94
				CHECK POOL 667033 TOTAL FOR FUND 592:			<u>1,202.86</u>
05/29/2024	POOL	667098*#	ODP BUSINESS SOLUTIONS LLC	OFFICE SUPPLY	74000	1560	288.86
				Total for department 1560:			<u>29,261.45</u>
Department: 1580 WWTP							
05/09/2024	POOL	666786*#	DENCAP	DENTAL PREMIUMS	71900	1580	57.00
05/16/2024	POOL	666792*#	VERIZON WIRELESS	CELLULAR SERVICE	85300	1580	544.20
				CELLULAR SERVICE	85300	1580	352.48
				CHECK POOL 666792 TOTAL FOR FUND 592:			<u>896.68</u>
05/29/2024	POOL	666808	BRONER INC	MAINTENANCE SUPPLY	93001	1580	1,211.50
				MAINTENANCE SUPPLY	93001	1580	165.04
				CHECK POOL 666808 TOTAL FOR FUND 592:			<u>1,376.54</u>
05/29/2024	POOL	666818*#	FEDERAL EXPRESS CORP	SHIPPING SERVICE	74000	1580	43.00
				SHIPPING SERVICE	74000	1580	121.34
				CHECK POOL 666818 TOTAL FOR FUND 592:			<u>164.34</u>
05/29/2024	POOL	666821*#	GRAINGER INC	OPERATING SUPPLY	93001	1580	116.88
				OPERATING SUPPLY	93001	1580	1,153.62
				OPERATING SUPPLY	93001	1580	21.29
				OPERATING SUPPLY	93001	1580	277.51
				OPERATING SUPPLY	93001	1580	1,153.62
				OPERATING SUPPLY	93001	1580	179.82
				OPERATING SUPPLY	93001	1580	457.24

Check Date	Bank	Check #	Payee	Description	Account	Dept	Amount
Fund: 592 WATER & SEWER SYSTEM FUND							
Department: 1580 WWTP							
				CREDIT MEMO	93001	1580	(1,153.62)
				CHECK POOL 666821 TOTAL FOR FUND 592:			<u>2,206.36</u>
05/29/2024	POOL	666831*#	SUPPLYDEN INC	JANITORIAL SUPPLY	93001	1580	321.05
05/29/2024	POOL	666832	GRAYBAR ELECTRIC COMPANY	ELECTRICAL SUPPLY	93001	1580	2,048.40
				ELECTRICAL SUPPLY	93001	1580	204.86
				ELECTRICAL SUPPLY	93001	1580	870.75
				CHECK POOL 666832 TOTAL FOR FUND 592:			<u>3,124.01</u>
05/29/2024	POOL	666835*#	CITY OF WARREN	WATER SERVICE	92000	1580	30.18
				WATER SERVICE	92000	1580	4,776.67
				WATER SERVICE	92000	1580	122.24
				WATER SERVICE	92000	1580	17,165.56
				WATER SERVICE	92000	1580	9.05
				WATER SERVICE	92000	1580	49.59
				CHECK POOL 666835 TOTAL FOR FUND 592:			<u>22,153.29</u>
05/29/2024	POOL	666837*#	WARREN PIPE & SUPPLY CO	MAINTENANCE SUPPLY	93001	1580	26.98
				MAINTENANCE SUPPLY	93001	1580	81.53
				MAINTENANCE SUPPLY	93001	1580	4.50
				MAINTENANCE SUPPLY	93001	1580	24.34
				CHECK POOL 666837 TOTAL FOR FUND 592:			<u>137.35</u>
05/29/2024	POOL	666845	OSCAR W LARSON CO	FUEL TANK MAINTENANCE	74300	1580	315.00
05/29/2024	POOL	666850	JADE SCIENTIFIC INC	LAB SUPPLY	74300	1580	150.75
05/29/2024	POOL	666862	MWEA	MEMBERSHIP DUES	71302	1580	95.00
				MEMBERSHIP DUES	71302	1580	460.00
				MEMBERSHIP DUES	71302	1580	400.00
				MEMBERSHIP DUES	71302	1580	460.00
				MEMBERSHIP DUES	71302	1580	560.00
				CHECK POOL 666862 TOTAL FOR FUND 592:			<u>1,975.00</u>
05/29/2024	POOL	666863	INGERSOLL-RAND INDUSTRIAL US INC	MAINTENANCE SERVICE	93001	1580	3,054.83
05/29/2024	POOL	666864	TETRA TECH INC	ENGINEERING SERVICES	80100	1580	1,401.37

Check Date	Bank	Check #	Payee	Description	Account	Dept	Amount
Fund: 592 WATER & SEWER SYSTEM FUND							
Department: 1580 WWTP							
05/29/2024	POOL	666865*#	AIRGAS USA LLC	RENTAL FEE	74300	1580	192.82
05/29/2024	POOL	666867	METRO WELDING SUPPLY	MAINTENANCE SUPPLY	93001	1580	38.75
05/29/2024	POOL	666868	UNCONVENTIONAL SOLUTIONS	MAINTENANCE SUPPLIES	93001	1580	1,965.53
05/29/2024	POOL	666869#	MAURER'S TEXTILE RENTAL	MAINTENANCE SERVICE	93020	1580	49.87
				MAINTENANCE SERVICE	93020	1580	17.50
				MAINTENANCE SERVICE	93020	1580	17.50
				MAINTENANCE SERVICE	93020	1580	17.50
				MAINTENANCE SERVICE	93020	1580	49.87
				MAINTENANCE SERVICE	93020	1580	29.18
				CHECK POOL 666869 TOTAL FOR FUND 592:			<u>181.42</u>
05/29/2024	POOL	666874	PERLMUTTER PURCHASING PWR	COMPUTER SUPPLY	93001	1580	480.00
05/29/2024	POOL	666877	CAPP/USA	ELECTRICAL SUPPLY	93001	1580	2,589.00
05/29/2024	POOL	666878	FLUKE ELECTRONICS	CALIBRATION	93001	1580	843.60
05/29/2024	POOL	666879	ALS ENVIRONMENTAL	LAB ANALYSIS	74300	1580	435.00
				PFAS TESTING	74300	1580	460.00
				METALS SAMPLE & TESTING	74300	1580	105.00
				CHECK POOL 666879 TOTAL FOR FUND 592:			<u>1,000.00</u>
05/29/2024	POOL	666880	UTILITIES INSTRUMENTATION	INSTRUMENTATION CALIBRATION	93001	1580	4,536.00
05/29/2024	POOL	666881	BAKER'S GAS AND WELDING SUPPLIES	SPECIALTY GASES	74300	1580	86.72
				SPECIALTY GASES	74300	1580	115.45
				CHECK POOL 666881 TOTAL FOR FUND 592:			<u>202.17</u>
05/29/2024	POOL	666911*#	ULINE INC	SAFETY EQUIPMENT	74000	1580	3,816.32
				SAFETY EQUIPMENT	74000	1580	994.86
				CHECK POOL 666911 TOTAL FOR FUND 592:			<u>4,811.18</u>
05/29/2024	POOL	666917	DELL MARKETING LP	COMPUTER SUPPLY	93001	1580	1,328.14
05/29/2024	POOL	666949*#	RKA PETROLEUM COMPANIES	DIESEL FUEL	92005	1580	8,954.03
				CREDIT MEMO	92005	1580	(8,954.03)
				CHECK POOL 666949 TOTAL FOR FUND 592:			<u>0.00</u>

05/22/2024 11:26 AM
 User: tcameron
 DB: Warren

CHECK DISBURSEMENT REPORT FOR CITY OF WARREN
 CHECK NUMBER 666777 - 667227

Check Date	Bank	Check #	Payee	Description	Account	Dept	Amount
Fund: 592 WATER & SEWER SYSTEM FUND							
Department: 1580 WWTP							
05/29/2024	POOL	666986*#	APPLIED INNOVATION	PRINTER MAINTENANCE	93001	1580	14.15
05/29/2024	POOL	667010	LIGHTING SUPPLY COMPANY	ELECTRICAL SUPPLY	93001	1580	2,269.39
05/29/2024	POOL	667024	EVOQUA WATER TECHNOLOGIES	AUTOMATED DIGITAL METERING	74300	1580	539.44
				CHEMICALS	74300	1580	104.42
				CHECK POOL 667024 TOTAL FOR FUND 592:			<u>643.86</u>
05/29/2024	POOL	667033*#	DEARBORN NATIONAL LIFE INSURANCE	LIFE AND AD&D PREMIUM	71900	1580	845.67
				DISABILITY PREMIUM	71900	1580	1,579.38
				LONG TERM DISABILITY PREMIUM	71900	1580	440.70
				CHECK POOL 667033 TOTAL FOR FUND 592:			<u>2,865.75</u>
05/29/2024	POOL	667034	R S DALE COMPANY INC	MAINTENANCE SUPPLY	93001	1580	2,695.15
				MAINTENANCE SUPPLY	93001	1580	876.00
				MAINTENANCE SUPPLY	93001	1580	252.00
				CHECK POOL 667034 TOTAL FOR FUND 592:			<u>3,823.15</u>
05/29/2024	POOL	667039	ROY SMITH COMPANY	SPECIALTY GASES	74300	1580	1,473.00
05/29/2024	POOL	667048*#	PRIORITY WASTE LLC	TRASH REMOVAL	93001	1580	225.72
				TRASH REMOVAL	93001	1580	33.44
				CHECK POOL 667048 TOTAL FOR FUND 592:			<u>259.16</u>
05/29/2024	POOL	667049	CANIFF ELECTRIC SUPPLY	ELECTRICAL SUPPLY	93001	1580	3,802.89
				ELECTRICAL SUPPLY	93001	1580	440.70
				ELECTRICAL SUPPLY	93001	1580	96.80
				CREDIT MEMO	93001	1580	(444.30)
				CHECK POOL 667049 TOTAL FOR FUND 592:			<u>3,896.09</u>
05/29/2024	POOL	667053	TRACE ANALYTICAL LABORATORIES INC	LAB SAMPLE ANALYSIS	74300	1580	50.75
05/29/2024	POOL	667054*#	AMERICAN PEST CONTROL INC	PEST CONTROL	93001	1580	28.00
				PEST CONTROL	93001	1580	10.00
				PEST CONTROL	93001	1580	10.00
				PEST CONTROL	93001	1580	156.00
				PEST CONTROL	93001	1580	10.00
				CHECK POOL 667054 TOTAL FOR FUND 592:			<u>214.00</u>

Check Date	Bank	Check #	Payee	Description	Account	Dept	Amount
Fund: 592 WATER & SEWER SYSTEM FUND							
Department: 1580 WWTP							
05/29/2024	POOL	667055	TEDESCO BUILDING SERVICES INC	JANITORIAL SERVICE	93020	1580	5,750.67
				JAINITORIAL SERVICE	93020	1580	672.00
				CHECK POOL 667055 TOTAL FOR FUND 592:			<u>6,422.67</u>
05/29/2024	POOL	667067	LLOYD RUDOLPH	REIMBURSEMENT	96201	1580	75.00
05/29/2024	POOL	667074	RPM	MAINTENANCE SUPPLY	93001	1580	145.57
05/29/2024	POOL	667082*#	ASCENTIS CORPORATION	ATTENDANCE SERVICE	74000	1580	194.20
05/29/2024	POOL	667097	PREMIER GROUP ASSOCIATES LC	LAWN MOWING SERVICE	93001	1580	1,490.80
				LAWN MOWING SERVICE	93001	1580	3,602.20
				CHECK POOL 667097 TOTAL FOR FUND 592:			<u>5,093.00</u>
05/29/2024	POOL	667109	MOTION & CONTROL ENTERPRISES LLC	MAINTENANCE MATERIALS	93001	1580	212.76
05/29/2024	POOL	667113*#	BMW KAR WASH LLC	CAR WASH SERVICE	86300	1580	4.75
05/29/2024	POOL	667119	ROWLEYS WHOLESALE	OIL PRODUCTS	93001	1580	1,498.82
05/29/2024	POOL	667120#	USABLUEBOOK	LAB EQUIPMENT/SUPPLIES	93001	1580	179.90
				LAB EQUIPMENT/SUPPLIES	93001	1580	716.13
				CHECK POOL 667120 TOTAL FOR FUND 592:			<u>896.03</u>
05/29/2024	POOL	667125	KLOCHKO EQUIPMENT RENTAL COMPANY	EQUIPMENT SERVICE/REPAIR	93001	1580	902.94
05/29/2024	POOL	667127	EUROFINS ENVIRONMENT TESTING	LAB ANALYSIS	74000	1580	401.50
05/29/2024	POOL	667143	RS AMERICAS INC	COMPUTER SUPPLIES	93001	1580	481.20
05/29/2024	POOL	667218*#	FERGUSON WATERWORKS	OPERATING PARTS	93001	1580	827.98
				OPERATING PARTS	93001	1580	2,523.99
				CHECK POOL 667218 TOTAL FOR FUND 592:			<u>3,351.97</u>
				Total for department 1580:			90,691.89
Department: 9044 EXPENSE							
05/29/2024	POOL	666820*#	FLORENCE CEMENT CO	WATER MAIN AND PAVEMENT RECONSTRUCTION	97001	9044	139,175.77
05/29/2024	POOL	666873#	DVM UTILITIES INC	SANITARY SEWER LINING	97001	9044	216,091.40

Check Date	Bank	Check #	Payee	Description	Account	Dept	Amount
Fund: 592 WATER & SEWER SYSTEM FUND							
Department: 9044 EXPENSE							
05/29/2024	POOL	667044*#	MARK ANTHONY CONTRACTING INC	ROAD CONSTRUCTION AND WATER MAIN	97001	9044	47,917.14
Total for department 9044:							403,184.31
Department: 9047 EXPENSE							
05/29/2024	POOL	666823*#	HAMILTON CHEVROLET INC	VEHICLE PURCHASE	98080	9047	45,999.00
05/29/2024	POOL	667075#	COMMERCIAL CONTRACTING CORPORATION	DETENTION BASIN	98080	9047	376,295.33
05/29/2024	POOL	667080	TIMMONS GROUP INC	WORK ORDER SYSTEM	98040	9047	2,681.25
05/29/2024	POOL	667120#	USABLUBOOK	ELECTRICAL REPAIR	98080	9047	9,495.00
Total for department 9047:							434,470.58
Total for fund 592 WATER & SEWER SYSTEM FUND							1,033,843.00

05/22/2024 11:26 AM
User: tcameron
DB: Warren

CHECK DISBURSEMENT REPORT FOR CITY OF WARREN
CHECK NUMBER 666777 - 667227

Check Date	Bank	Check #	Payee	Description	Account	Dept	Amount
Fund: 596 W&S PAYROLL REVOLVING FUND							
Department: 0000							
05/16/2024	POOL	666797*	WARREN MUNICIPAL FEDERAL	PAYROLL DEDUCTIONS	23101	0000	8,144.00
05/16/2024	POOL	666800*	MISDU	PAYROLL DEDUCTIONS	23200	0000	850.35
05/16/2024	POOL	666801	CHAPTER 13 TRUSTEE	PAYROLL DEDUCTION	23200	0000	1,093.00
05/16/2024	POOL	666802*	LOCAL U227	UNION DUES DEDUCTIONS	23110	0000	1,830.00
05/29/2024	POOL	667175*	LOCAL 412	UNION DUES DEDUCTIONS	23112	0000	155.81
05/29/2024	POOL	667182*	WARREN SUPERVISORS	UNION DUES DEDUCTIONS	23111	0000	720.00
Total for department 0000:							12,793.16
Total for fund 596 W&S PAYROLL REVOLVING FUND							12,793.16

Check Date	Bank	Check #	Payee	Description	Account	Dept	Amount
Fund: 701 UNALLOCATED TAX FUND							
Department: 0000							
05/29/2024	POOL	667212	RESTAURANT BRAND INTERNATIONAL	DUPLICATE PAYEMENT	20222	0000	300.00
Total for department 0000:							300.00
Total for fund 701 UNALLOCATED TAX FUND							300.00

05/22/2024 11:26 AM
User: tcameron
DB: Warren

CHECK DISBURSEMENT REPORT FOR CITY OF WARREN
CHECK NUMBER 666777 - 667227

Check Date	Bank	Check #	Payee	Description	Account	Dept	Amount
Fund: 750 PAYROLL REVOLVING FUND							
Department: 0000							
05/16/2024	POOL	666796	WARREN POLICE COMMAND	PAYROLL DEDUCTIONS	23118	0000	1,711.13
05/16/2024	POOL	666797*	WARREN MUNICIPAL FEDERAL	PAYROLL DEDUCTIONS	23101	0000	62,099.00
05/16/2024	POOL	666798	CHPTR 13 STANDING TRUSTEE	PAYROLL DEDUCTION	23200	0000	1,277.74
05/16/2024	POOL	666799	CHPTR 13 STANDING TRUSTEE	PAYROLL DEDUCTION	23200	0000	453.98
05/16/2024	POOL	666800*	MISDU	PAYROLL DEDUCTIONS	23200	0000	8,813.63
05/16/2024	POOL	666802*	LOCAL U227	UNION DUES DEDUCTIONS	23110	0000	6,480.00
05/16/2024	POOL	666803	U.S. ASSET MANAGEMENT	PAYROLL DEDUCTION	23200	0000	541.65
05/29/2024	POOL	667175*	LOCAL 412	UNION DUES DEDUCTIONS	23112	0000	1,530.94
05/29/2024	POOL	667176	FOP LODGE 124	PAYROLL DEDUCTIONS	23116	0000	3,285.00
05/29/2024	POOL	667177	INT ASSOC OF FIREFIGHTERS	PAYROLL DEDUCTIONS	23113	0000	14,800.81
05/29/2024	POOL	667178	WARREN FIRE FIGHTER FUND	PAYROLL DEDUCTIONS	23114	0000	1,330.00
05/29/2024	POOL	667182*	WARREN SUPERVISORS	UNION DUES DEDUCTIONS	23111	0000	1,800.00
Total for department 0000:							104,123.88
Total for fund 750 PAYROLL REVOLVING FUND							104,123.88

Check Date	Bank	Check #	Payee	Description	Account	Dept	Amount
Fund: 801 S/A REVOLVING FUND							
Department: 9801 S/A REVOLVING EXPENDITURE							
05/29/2024	POOL	667103	THE ADAMS GROUP INC	DEMOLITION	96700	9801	13,646.00
05/29/2024	POOL	667128	BRADLEY G SMITH	ASBESTOS SURVEYS	96700	9801	380.00
				ASBESTOS SURVEYS	96700	9801	440.00
CHECK POOL 667128 TOTAL FOR FUND 801:							820.00
Total for department 9801:							14,466.00
Total for fund 801 S/A REVOLVING FUND							14,466.00

Check Date	Bank	Check #	Payee	Description	Account	Dept	Amount
Fund: 802 SIDEWALK & TREE S/A FUND							
Department: 0080 REVENUES							
05/29/2024	POOL	667215	MACOMB COUNTY TREASURER	2022 DELINQUENT TAXES	44500	0080	469.29
Total for department 0080:							469.29
Total for fund 802 SIDEWALK & TREE S/A FUND							469.29
TOTAL - ALL FUNDS							4,358,209.25

'*'-INDICATES CHECK DISTRIBUTED TO MORE THAN ONE FUND

'#'-INDICATES CHECK DISTRIBUTED TO MORE THAN ONE DEPARTMENT

CITY OF WARREN
BILLS TO BE APPROVED FOR PAYMENT
REGULAR MEETING OF MAY 28, 2024

WIRE TRANSFERS TO TAXING AUTHORITIES

<u>SCHOOL DISTRICT</u>	<u>4/29/2024</u>
FITZGERALD	174,998.92
VAN DYKE	212,948.29
EAST DETROIT	26,862.87
CENTER LINE	56,203.13
WARREN WOODS	169,891.23
WARREN CON	715,563.16
MACOMB COMM	254,421.25
MACOMB INTER	559,906.42
MACOMB COUNTY	213,947.45
TOTAL	<hr/> <u>\$2,384,742.72</u> <hr/>

TOTAL FOR APRIL 2024 DISBURSEMENTS
TO TAXING AUTHORITIES \$2,384,742.72

CITY OF WARREN
 BILLS TO BE APPROVED FOR PAYMENT
 REGULAR MEETING OF MAY 28, 2024

MISCELLANEOUS WIRE TRANSFERS

<u>TRANSFER TO</u>	<u>DATE</u>	<u>AMOUNT</u>
ICMA-DEF COMP	4/4/2024	108,425.33
ICMA-DEF COMP	4/18/2024	79,969.86
ICMA-401A	4/4/2024	142,842.09
ICMA-401A	4/18/2024	165,059.16
ICMA-ROTH IRA	4/4/2024	18,721.47
ICMA-ROTH IRA	4/18/2024	17,721.47
ICMA-RHS	4/4/2024	85,134.88
ICMA-RHS	4/18/2024	89,600.02
VOYA-DEF COMP	4/4/2024	12,205.69
VOYA-DEF COMP	4/18/2024	12,030.69
WAGWORKS	4/4/2024	20,269.99
WAGWORKS	4/18/2024	20,898.34
P&F VEBA-EE	4/16/2024	132,372.21
CITY RETIREMENT	4/26/2024	429,590.00
P&F RETIREMENT	4/26/2024	1,192,186.00
P&F VEBA	4/26/2024	630,380.00
COMPONE ADMIN	4/29/2024	10,100.00
ASU GROUP	4/17/2024	29,120.30
ASU GROUP	4/17/2024	13,693.13
ASU GROUP	4/17/2024	35,108.91
ASU GROUP	4/17/2024	14,002.00
ASU GROUP	4/30/2024	21,496.38
ASU GROUP	4/30/2024	16,763.00
ASU GROUP	4/30/2024	19,032.00
MICROSOFT	4/16/2024	3,162.00
APRIL 2024	TOTAL	\$3,319,884.92

WIRES FOR HEALTH CARE CLAIMS

<u>TRANSFER TO</u>	<u>DATE</u>	<u>AMOUNT</u>
BC/BS	4/2/2024	350,170.57
BC/BS	4/9/2024	659,259.44
BC/BS	4/16/2024	540,829.97
BC/BS	4/23/2024	904,585.65
BC/BS	4/30/2024	424,045.19
APRIL 2024	TOTAL	\$2,878,890.82

WIRE TRANSFERS TO MACOMB COUNTY

<u>TRANSFER TO</u>	<u>DATE</u>	<u>AMOUNT</u>
MACOMB COUNTY	4/29/2024	1,113,242.92

APRIL 2024	TOTAL	\$1,113,242.92
-------------------	--------------	-----------------------

WIRES FOR FEDERAL W/HOLDING TAX

<u>PAID FROM</u>	<u>DATE</u>	<u>AMOUNT</u>
COMERICA BANK	4/3/2024	492,187.01
COMERICA BANK	4/17/2024	554,836.56
APRIL 2024	TOTAL	\$1,047,023.57

CITY OF WARREN
 BILLS TO BE APPROVED FOR PAYMENT
 REGULAR MEETING OF MAY 28, 2024
 PENDING WIRE TRANSFERS

<u>TRANSFER TO</u>	<u>REASON</u>	<u>DATE REQUESTED</u>	<u>AMOUNT REQUESTED</u>
THE ASU GROUP	REIMBURSE LARGE DOLLAR CLAIM	5/20/24	45,279.84
THE ASU GROUP	REIMBURSE LARGE DOLLAR CLAIM	5/20/24	15,459.01
TOTAL	WIRES TO BE EFFECTUATED	6/3/24	<u>\$60,738.85</u>

REVENUE AND EXPENDITURE REPORT

PERIOD ENDING 04/30/2024

% Fiscal Year Completed: 83.33

GL NUMBER	DESCRIPTION	END BALANCE	2023-24		YTD BALANCE	ENCUMBERED	UNENCUMBERED	% BDGT
		06/30/2023	ORIGINAL	2023-24	04/30/2024			
		NORM (ABNORM)	BUDGET	AMENDED BUDGET	NORM (ABNORM)	YEAR-TO-DATE	BALANCE	USED
Fund 101 - GENERAL FUND								
Dept 0080 - REVENUES								
101-0080-40300	TAX COLLECTIONS	16,954.00	0.00	0.00	13,137.49	0.00	(13,137.49)	100.00
101-0080-40301	PROPERTY TAXES: CHARTER	32,046,090.04	33,808,316.00	33,808,316.00	28,342,297.08	0.00	5,466,018.92	83.83
101-0080-40303	PROPERTY TAX: P&F PENSION	19,235,040.49	20,240,407.00	20,240,407.00	16,967,048.90	0.00	3,273,358.10	83.83
101-0080-40305	PROPERTY TAX: EMS	1,076,014.44	1,124,738.00	1,124,738.00	942,892.13	0.00	181,845.87	83.83
101-0080-40306	PROPERTY TAX: POLICE	3,574,839.50	3,771,729.00	3,771,729.00	3,161,924.90	0.00	609,804.10	83.83
101-0080-40307	PROPERTY TAX: FIRE	3,574,840.40	3,771,729.00	3,771,729.00	3,161,924.90	0.00	609,804.10	83.83
101-0080-40311	PROPERTY TAX: P&F OPER.	17,957,963.95	18,978,832.00	18,978,832.00	15,910,370.91	0.00	3,068,461.09	83.83
101-0080-40400	PYMT IN LIEU OF PROP TAX	28,125.00	29,238.00	29,238.00	0.00	0.00	29,238.00	0.00
101-0080-40500	TRAILER PARK TAXES	6,049.00	3,762.00	3,762.00	4,613.50	0.00	(851.50)	122.63
101-0080-43701	IF TAX: CHARTER	210,929.79	430,295.00	430,295.00	358,580.00	0.00	71,715.00	83.33
101-0080-43703	IF TAX: P&F PENSION	162,251.41	257,612.00	257,612.00	214,680.00	0.00	42,932.00	83.33
101-0080-43705	IF TAX: EMS	7,017.02	14,315.00	14,315.00	11,930.00	0.00	2,385.00	83.34
101-0080-43706	IF TAX: POLICE	23,531.59	48,000.00	48,000.00	40,000.00	0.00	8,000.00	83.33
101-0080-43707	IF TAX: FIRE	23,531.59	48,000.00	48,000.00	40,000.00	0.00	8,000.00	83.33
101-0080-43711	IF TAX: POLICE & FIRE OP	118,408.69	241,550.00	241,550.00	201,290.00	0.00	40,260.00	83.33
101-0080-44500	PENALTIES & INT ON TAXES	450,984.39	300,000.00	300,000.00	34,166.50	0.00	265,833.50	11.39
101-0080-47600	MECHANICAL PERMITS	463,074.00	500,000.00	500,000.00	330,899.00	0.00	169,101.00	66.18
101-0080-47800	BUILDING PERMITS	1,114,228.00	1,900,000.00	1,900,000.00	521,141.40	0.00	1,378,858.60	27.43
101-0080-47900	ELECTRICAL PERMITS	558,071.52	745,000.00	745,000.00	398,329.76	0.00	346,670.24	53.47
101-0080-48000	MARIJUANA LICENSES	1,404,420.00	1,300,000.00	1,300,000.00	1,116,071.00	0.00	183,929.00	85.85
101-0080-48100	PLUMBING PERMITS	186,223.00	410,000.00	410,000.00	126,540.00	0.00	283,460.00	30.86
101-0080-48200	PLAN REVIEW FEES	312,220.00	440,000.00	440,000.00	265,191.20	0.00	174,808.80	60.27
101-0080-48300	ANIMAL LICENSES	13,225.20	25,000.00	25,000.00	11,078.10	0.00	13,921.90	44.31
101-0080-48400	SIDEWALK PERMITS	7,766.70	20,000.00	20,000.00	4,965.00	0.00	15,035.00	24.83
101-0080-48500	OTHER LICENSES & PERMITS	378,219.06	375,000.00	375,000.00	366,794.29	0.00	8,205.71	97.81
101-0080-48600	ZONING PERMITS	156,663.80	190,000.00	190,000.00	115,968.80	0.00	74,031.20	61.04
101-0080-48700	DEMOLITION PERMITS	14,700.00	0.00	0.00	13,972.00	0.00	(13,972.00)	100.00
101-0080-48800	DAY CARE REGISTRATION	0.00	0.00	0.00	45.00	0.00	(45.00)	100.00
101-0080-50500	POLICE CIVIL DEFENSE	78,592.36	0.00	0.00	55,983.85	0.00	(55,983.85)	100.00
101-0080-50501	2022 JAG GRANT	68,522.76	0.00	0.00	0.00	0.00	0.00	0.00
101-0080-50506	2020 DOJ CORONAVIRUS CESF	55,315.83	0.00	0.00	0.00	0.00	0.00	0.00
101-0080-50507	2020 JAG REVENUE	12,607.15	0.00	0.00	0.00	0.00	0.00	0.00
101-0080-50508	2019 HOMELAND SECURITY GRANT F	7,038.00	0.00	0.00	0.00	0.00	0.00	0.00
101-0080-50509	2019 JAG REVENUE - SIMULATOR	9,775.00	0.00	0.00	0.00	0.00	0.00	0.00
101-0080-50511	2020 DOJ CORONAVIRUS CESF - CC	31,315.23	0.00	0.00	4,249.50	0.00	(4,249.50)	100.00
101-0080-50513	2023 JAG REVENUE	0.00	0.00	86,318.00	0.00	0.00	86,318.00	0.00
101-0080-52800	OTHER FEDERAL GRANTS COVID19/A	37,638.50	0.00	0.00	3,617.00	0.00	(3,617.00)	100.00
101-0080-53601	COMMUNITY DEV ADMIN	98,553.79	195,000.00	195,000.00	63,637.83	0.00	131,362.17	32.63
101-0080-53603	911 DISPATCH TRAIN EQUIP	603,071.17	670,000.00	670,000.00	738,610.04	0.00	(68,610.04)	110.24
101-0080-53604	COMM DEV REIMB	80,000.00	90,000.00	90,000.00	70,907.38	0.00	19,092.62	78.79
101-0080-53619	STATE HOMELAND SEC GRT	3,286.42	0.00	0.00	0.00	0.00	0.00	0.00
101-0080-53691	SUBSTANCE ABUSE GRT FY22 REV	91,793.19	0.00	0.00	0.00	0.00	0.00	0.00
101-0080-53692	MICH DRUG COURT GRT FY22 REV	6,408.59	0.00	0.00	0.00	0.00	0.00	0.00
101-0080-53693	SUBSTANCE ABUSE GRT FY23 REV	191,465.93	0.00	0.00	57,300.03	0.00	(57,300.03)	100.00
101-0080-53694	MICH DRUG COURT GRT FY23 REV	44,760.12	0.00	0.00	12,823.00	0.00	(12,823.00)	100.00
101-0080-53697	SUBSTANCE ABUSE GRT FY 24 REV	0.00	0.00	400,000.00	148,472.14	0.00	251,527.86	37.12
101-0080-53698	MICH DRUG COURT GRT FY24 REV	0.00	0.00	23,000.00	2,535.00	0.00	20,465.00	11.02
101-0080-55900	MEDICAL MARIJUANA EXCISE TAX	9,145.48	0.00	0.00	39,485.06	0.00	(39,485.06)	100.00
101-0080-56652	BULLETPROOF VEST	18,231.46	0.00	0.00	0.00	0.00	0.00	0.00
101-0080-57300	LOCAL COMM STABILIZ SHARE	4,236,589.49	6,000,000.00	6,000,000.00	3,794,726.59	0.00	2,205,273.41	63.25
101-0080-57502	SALES TAXES	18,032,702.00	18,560,248.00	18,560,248.00	12,496,649.00	0.00	6,063,599.00	67.33
101-0080-57504	LIQUOR LICENSES	99,141.35	80,000.00	80,000.00	86,763.60	0.00	(6,763.60)	108.45
101-0080-58100	REIMB CENTER LINE COURT	525,324.46	375,000.00	375,000.00	545,390.13	0.00	(170,390.13)	145.44
101-0080-60800	BOARD OF APPEALS	32,690.00	40,000.00	40,000.00	23,445.00	0.00	16,555.00	58.61
101-0080-60900	TAX COLL FEE - NON CITY	1,425,165.88	1,300,000.00	1,300,000.00	6,042.53	0.00	1,293,957.47	0.46
101-0080-61100	CITY CLERK	128,812.50	208,624.00	208,624.00	108,894.20	0.00	99,729.80	52.20

REVENUE AND EXPENDITURE REPORT

PERIOD ENDING 04/30/2024

% Fiscal Year Completed: 83.33

GL NUMBER	DESCRIPTION	END BALANCE	2023-24		YTD BALANCE	ENCUMBERED	UNENCUMBERED	% BDGT
		06/30/2023	ORIGINAL	2023-24	04/30/2024			
		NORM (ABNORM)	BUDGET	AMENDED BUDGET	NORM (ABNORM)			
Fund 101 - GENERAL FUND								
101-0080-62100	SITE PLANS FEES	54,220.00	45,000.00	45,000.00	76,563.40	0.00	(31,563.40)	170.14
101-0080-62200	PLANNING COMMISSION FEES	32,226.44	30,000.00	30,000.00	13,875.00	0.00	16,125.00	46.25
101-0080-62300	PROCESSING PA 198 IFT CER	2,500.00	1,500.00	1,500.00	1,000.00	0.00	500.00	66.67
101-0080-62700	FORESTRY - TREE PLANTING	400.00	0.00	0.00	200.00	0.00	(200.00)	100.00
101-0080-62900	REIMB JUDGES' SAL STANDZN	156,165.08	182,896.00	182,896.00	137,172.00	0.00	45,724.00	75.00
101-0080-62910	ELECTION EXP REIMBURSEMT	91,912.02	132,000.00	132,000.00	34,055.08	0.00	97,944.92	25.80
101-0080-63100	REIMBURSE FROM SCHOOLS	565,598.66	490,000.00	490,000.00	180,000.00	0.00	310,000.00	36.73
101-0080-63200	PROBATION FEES	180,492.92	250,000.00	250,000.00	152,462.88	0.00	97,537.12	60.99
101-0080-63400	ENGINEERING & INSP FEES	121,822.00	80,000.00	80,000.00	67,597.50	0.00	12,402.50	84.50
101-0080-63404	FORECLOSURE FEE	67,350.00	70,000.00	70,000.00	67,100.00	0.00	2,900.00	95.86
101-0080-63700	TOWING ADMIN FEE	189,550.00	180,000.00	180,000.00	130,350.00	0.00	49,650.00	72.42
101-0080-63800	POLICE FEES	400,136.00	250,000.00	250,000.00	345,884.32	0.00	(95,884.32)	138.35
101-0080-63900	FIRE REVENUES	24,360.84	15,000.00	15,000.00	37,500.55	0.00	(22,500.55)	250.00
101-0080-63901	EMS REVENUE	4,111,489.69	3,800,000.00	3,800,000.00	2,943,489.73	0.00	856,510.27	77.46
101-0080-64100	WEED CUTTING	102,880.97	175,000.00	175,000.00	80,006.25	0.00	94,993.75	45.72
101-0080-65800	DISTRICT COURT FINES&FEES	3,228,296.67	4,098,982.00	4,098,982.00	2,500,984.31	0.00	1,597,997.69	61.01
101-0080-65802	DRUG COURT REVENUE	32,345.00	50,000.00	50,000.00	25,430.00	0.00	24,570.00	50.86
101-0080-65804	CIVIL FEES/DRUG TREATMENT	59,091.00	0.00	0.00	41,643.00	0.00	(41,643.00)	100.00
101-0080-65805	PROPERTY MAINTENANCE FINE	275,462.00	150,000.00	150,000.00	198,855.00	0.00	(48,855.00)	132.57
101-0080-66500	INTEREST ON INVESTMENTS	1,890,430.05	400,000.00	400,000.00	3,749,804.31	0.00	(3,349,804.31)	937.45
101-0080-66700	COURT BUILDING RENTAL	250,000.00	250,000.00	250,000.00	250,000.00	0.00	0.00	100.00
101-0080-66801	LEASE PROCEEDS	30,063.81	0.00	0.00	112,742.54	0.00	(112,742.54)	100.00
101-0080-67300	SALE OF EQUIPMENT	55,850.00	50,000.00	50,000.00	83,440.00	0.00	(33,440.00)	166.88
101-0080-67350	SALE OF PROPERTY	1,213.00	850,000.00	850,000.00	12.00	0.00	849,988.00	0.00
101-0080-67700	ADMINISTRATIVE FEES	5,620,641.37	5,834,800.00	5,834,800.00	4,862,360.00	0.00	972,440.00	83.33
101-0080-67701	FLEET MAINTENANCE FEES	769,926.00	790,010.00	790,010.00	658,350.00	0.00	131,660.00	83.33
101-0080-67802	EQUIP RENTALS/SERVICE REIMB -	252,031.54	453,000.00	453,000.00	239,957.28	0.00	213,042.72	52.97
101-0080-67803	EQUIP RENTALS - LOCAL ST	882,200.93	1,033,000.00	1,033,000.00	848,044.19	0.00	184,955.81	82.10
101-0080-67804	SALT DOME RENTAL REVENUE	5,000.00	5,000.00	5,000.00	5,000.00	0.00	0.00	100.00
101-0080-67900	MISCELLANEOUS REVENUE	39,386.29	250,000.00	250,000.00	38,622.45	0.00	211,377.55	15.45
101-0080-67907	DONATIONS	0.00	5,000.00	5,000.00	3,000.00	0.00	2,000.00	60.00
101-0080-67913	TELECOM LEASES	35,895.96	35,000.00	35,000.00	76,040.67	0.00	(41,040.67)	217.26
101-0080-67920	EMG RUBBISH / BOARDINGS	3,920.86	0.00	0.00	1,435.46	0.00	(1,435.46)	100.00
101-0080-67921	SNOW REMOVALS	1,087.50	0.00	0.00	250.00	0.00	(250.00)	100.00
101-0080-67922	RODENT BAITING	188.00	0.00	0.00	84.00	0.00	(84.00)	100.00
101-0080-67923	BLIGHT BUSTERS	81,627.50	0.00	0.00	60,962.50	0.00	(60,962.50)	100.00
101-0080-68500	NATIONAL OPIOID SETTLEMENT	758,608.40	0.00	0.00	192,514.92	0.00	(192,514.92)	100.00
101-0080-69436	TRANSFER FROM FUND 436	0.04	0.00	0.00	0.00	0.00	0.00	0.00
101-0080-69901	FUND BALANCE APPROPRIATED	0.00	15,494,339.00	25,391,218.00	0.00	0.00	25,391,218.00	0.00
Net - Dept 0080 - REVENUES		129,423,699.78	151,942,922.00	162,349,119.00	109,152,173.08	0.00	53,196,945.92	

Dept 1101 - COUNCIL

101-1101-70200	ELECTED OFFICIALS	219,884.00	219,884.00	219,884.00	183,738.40	0.00	36,145.60	83.56
101-1101-70600	PERMANENT EMPLOYEES	163,186.08	273,075.00	273,075.00	133,508.61	0.00	139,566.39	48.89
101-1101-70900	OVERTIME	2,406.70	7,839.00	7,839.00	968.10	0.00	6,870.90	12.35
101-1101-71303	CLEAN/CLOTHING ALLOWANCE	650.00	1,400.00	1,400.00	700.00	0.00	700.00	50.00
101-1101-71500	SOCIAL SECURITY	29,976.38	39,454.00	39,454.00	25,113.64	0.00	14,340.36	63.65
101-1101-71900	EMPLOYEE INSURANCES	131,335.97	198,744.00	198,744.00	127,102.72	0.00	71,641.28	63.95
101-1101-71904	RETIREE HEALTH INSURANCE	68,511.00	68,511.00	68,511.00	57,090.00	0.00	11,421.00	83.33
101-1101-71905	H.S.A. EXPENSE	7,401.51	10,319.00	10,319.00	6,517.53	0.00	3,801.47	63.16
101-1101-71906	SUPPL LIFE INSURANCE EXP	726.00	776.00	776.00	310.00	0.00	466.00	39.95
101-1101-72100	LONGEVITY	3,136.86	5,917.00	5,917.00	5,916.76	0.00	0.24	100.00
101-1101-72101	BONUS/SICK REDEMPTION	7,239.00	7,457.00	7,457.00	7,456.20	0.00	0.80	99.99
101-1101-72200	RETIREMENT FUND	124,436.00	114,558.00	114,558.00	95,470.00	0.00	19,088.00	83.34
101-1101-72201	DEFINED CONTRIBUTION EXP	40,148.15	51,565.00	51,565.00	33,809.45	0.00	17,755.55	65.57

REVENUE AND EXPENDITURE REPORT

PERIOD ENDING 04/30/2024

% Fiscal Year Completed: 83.33

GL NUMBER	DESCRIPTION	END BALANCE	2023-24		YTD BALANCE	ENCUMBERED	UNENCUMBERED	% BDGT
		06/30/2023	ORIGINAL	2023-24	04/30/2024			
		NORM (ABNORM)	BUDGET	AMENDED BUDGET	NORM (ABNORM)	YEAR-TO-DATE	BALANCE	USED
Fund 101 - GENERAL FUND								
101-1101-72700	OFFICE SUPPLIES	1,372.00	17,215.00	17,215.00	9,124.97	6,091.38	1,998.65	88.39
101-1101-80100	CONTRACTUAL SERVICES	398,050.15	425,000.00	425,000.00	213,389.34	44,805.74	166,804.92	60.75
101-1101-80102	COURT REPORTER	0.00	1,200.00	1,200.00	0.00	0.00	1,200.00	0.00
101-1101-80200	POSTAGE	250.53	1,300.00	1,300.00	666.24	0.00	633.76	51.25
101-1101-85300	TELEPHONE & RADIO	441.60	1,100.00	1,100.00	262.70	0.00	837.30	23.88
101-1101-86100	MILEAGE	0.00	450.00	450.00	0.00	0.00	450.00	0.00
101-1101-90000	PRINTING & PUBLISHING	590.50	3,500.00	3,500.00	3,415.50	0.00	84.50	97.59
101-1101-98000	OFFICE EQUIPMENT	4,884.99	0.00	0.00	0.00	0.00	0.00	0.00
Net - Dept 1101 - COUNCIL		(1,204,627.42)	(1,449,264.00)	(1,449,264.00)	(904,560.16)	(50,897.12)	(493,806.72)	
Dept 1136 - 37TH DISTRICT COURT								
101-1136-70200	ELECTED OFFICIALS	156,692.68	183,612.00	183,612.00	147,020.27	0.00	36,591.73	80.07
101-1136-70600	PERMANENT EMPLOYEES	2,706,869.78	3,108,514.00	3,108,514.00	2,346,425.99	0.00	762,088.01	75.48
101-1136-70703	CLERICAL CO-OP	225,649.28	269,520.00	269,520.00	188,822.46	0.00	80,697.54	70.06
101-1136-70716	TEMPORARY - DRUG COURT	2,937.00	0.00	149,589.00	3,625.00	0.00	145,964.00	2.42
101-1136-70900	OVERTIME	2,574.18	5,025.00	30,025.00	516.38	0.00	29,508.62	1.72
101-1136-71303	CLEAN/CLOTHING ALLOWANCE	5,725.00	16,100.00	16,100.00	6,275.00	0.00	9,825.00	38.98
101-1136-71500	SOCIAL SECURITY	235,002.02	273,043.00	284,636.00	202,282.05	0.00	82,353.95	71.07
101-1136-71900	EMPLOYEE INSURANCES	725,595.23	887,144.00	887,144.00	667,901.21	0.00	219,242.79	75.29
101-1136-71904	RETIREE HEALTH INSURANCE	639,408.00	639,408.00	639,408.00	532,840.00	0.00	106,568.00	83.33
101-1136-71905	H.S.A. EXPENSE	37,576.06	44,528.00	44,528.00	34,059.69	0.00	10,468.31	76.49
101-1136-71906	SUPPL LIFE INSURANCE EXP	3,543.94	4,464.00	4,464.00	3,157.58	0.00	1,306.42	70.73
101-1136-72100	LONGEVITY	77,768.36	87,069.00	87,069.00	64,722.82	0.00	22,346.18	74.34
101-1136-72101	BONUS/SICK REDEMPTION	52,264.42	82,366.00	82,366.00	44,251.18	0.00	38,114.82	53.73
101-1136-72200	RETIREMENT FUND	684,398.00	630,058.00	630,058.00	525,050.00	0.00	105,008.00	83.33
101-1136-72201	DEFINED CONTRIBUTION EXP	281,922.29	318,577.00	318,577.00	245,863.78	0.00	72,713.23	77.18
101-1136-72700	OFFICE SUPPLIES	104,380.34	110,000.00	110,000.00	84,028.34	29,408.57	(3,436.91)	103.12
101-1136-74006	2020 DOJ CORONAVIRUS CESF - CC	31,315.23	0.00	21,740.00	4,924.50	0.00	16,815.50	22.65
101-1136-80008	PAID STATE OF MICHIGAN	21,347.71	45,000.00	45,000.00	23,711.10	0.00	21,288.90	52.69
101-1136-80100	CONTRACTUAL SERVICES	86,529.40	138,200.00	138,200.00	102,440.98	20,346.53	15,412.49	88.85
101-1136-80103	CONT SERV/MAGIST/VIST JUD	111,816.06	82,500.00	82,500.00	60,642.10	0.00	21,857.90	73.51
101-1136-80137	CONT SERV - DATA PROC	261,472.25	356,450.00	422,234.00	84,098.27	65,784.00	272,351.73	35.50
101-1136-80200	POSTAGE	20,451.46	122,000.00	122,000.00	93,525.49	1,210.40	27,264.11	77.65
101-1136-80202	BANK SERVICE CHARGES	15,817.85	16,000.00	16,000.00	10,730.12	0.00	5,269.88	67.06
101-1136-81900	TRANSCRIPTS	0.00	650.00	650.00	0.00	0.00	650.00	0.00
101-1136-82210	DRUG COURT GRANT EXPENSE	5,909.83	15,000.00	15,000.00	5,174.20	3,820.49	6,005.31	59.96
101-1136-82244	SUBSTANCE ABUSE GRT FY22 EXP	77,773.82	0.00	0.00	0.00	0.00	0.00	0.00
101-1136-82245	MICH DRUG COURT GRT FY22 EXP	6,408.59	0.00	0.00	0.00	0.00	0.00	0.00
101-1136-82246	SUBSTANCE ABUSE GRT FY23 EXP	153,231.80	0.00	141,656.00	42,473.33	0.00	99,182.67	29.98
101-1136-82247	MICH DRUG COURT GRT FY23 EXP	44,760.12	0.00	45,240.00	12,823.00	0.00	32,417.00	28.34
101-1136-82248	SUBSTANCE ABUSE GRT FY 24 EXP	0.00	0.00	305,698.00	105,426.47	57,351.21	142,920.32	53.25
101-1136-82249	MICH DRUG COURT GRT FY24 EXP	0.00	0.00	23,000.00	9,416.00	9,334.05	4,249.95	81.52
101-1136-83500	WITNESS & JURY FEES	13,382.20	15,000.00	15,000.00	6,405.20	0.00	8,594.80	42.70
101-1136-85300	TELEPHONE & RADIO	37,485.11	40,735.00	40,735.00	27,695.91	1,471.60	11,567.49	71.60
101-1136-86100	MILEAGE	186.46	1,700.00	1,700.00	220.74	0.00	1,479.26	12.98
101-1136-88001	COMMUNITY PROMOTION/OUTREACH E	0.00	500.00	500.00	0.00	0.00	500.00	0.00
101-1136-92000	PUBLIC UTILITIES	105,255.73	110,000.00	110,000.00	80,455.12	0.00	29,544.88	73.14
101-1136-94200	BUILDING RENTAL	250,000.00	250,000.00	250,000.00	250,000.00	0.00	0.00	100.00
101-1136-95800	MEMBERSHIPS & DUES	9,104.70	12,240.00	12,240.00	10,481.35	140.30	1,618.35	86.78
101-1136-96259	TRANSFER TO INDIGENT DEFENSE	123,769.06	135,000.00	135,000.00	123,769.06	0.00	11,230.94	91.68
101-1136-98200	BOOKS	13,512.77	13,500.00	13,500.00	10,744.44	2,330.56	425.00	96.85
Net - Dept 1136 - 37TH DISTRICT COURT		(7,331,836.73)	(8,013,903.00)	(8,803,203.00)	(6,161,999.12)	(191,197.71)	(2,450,006.17)	

REVENUE AND EXPENDITURE REPORT

PERIOD ENDING 04/30/2024

% Fiscal Year Completed: 83.33

GL NUMBER	DESCRIPTION	END BALANCE	2023-24		YTD BALANCE	ENCUMBERED	UNENCUMBERED	% BDGT
		06/30/2023	ORIGINAL	2023-24	04/30/2024			
		NORM (ABNORM)	BUDGET	AMENDED BUDGET	NORM (ABNORM)	YEAR-TO-DATE	BALANCE	USED
Fund 101 - GENERAL FUND								
Dept 1171 - MAYOR								
101-1171-70200	ELECTED OFFICIALS	126,125.24	126,133.00	126,133.00	100,996.95	0.00	25,136.05	80.07
101-1171-70600	PERMANENT EMPLOYEES	206,855.55	348,495.00	348,495.00	177,397.56	0.00	171,097.44	50.90
101-1171-70703	CLERICAL CO-OP	28,080.82	35,000.00	35,000.00	16,080.27	0.00	18,919.73	45.94
101-1171-70900	OVERTIME	0.00	0.00	4,055.00	4,367.00	0.00	(312.00)	107.69
101-1171-71303	CLEAN/CLOTHING ALLOWANCE	900.00	1,750.00	1,750.00	1,116.67	0.00	633.33	63.81
101-1171-71500	SOCIAL SECURITY	28,829.08	40,172.00	40,172.00	23,451.72	0.00	16,720.28	58.38
101-1171-71900	EMPLOYEE INSURANCES	41,296.90	108,541.00	108,541.00	28,240.98	0.00	80,300.02	26.02
101-1171-71904	RETIREE HEALTH INSURANCE	22,837.00	22,837.00	22,837.00	19,030.00	0.00	3,807.00	83.33
101-1171-71905	H.S.A. EXPENSE	4,512.52	7,281.00	7,281.00	4,891.29	0.00	2,389.71	67.18
101-1171-71906	SUPL LIFE INSURANCE EXP	0.00	0.00	300.00	162.56	0.00	137.44	54.19
101-1171-72100	LONGEVITY	5,976.64	6,054.00	6,054.00	3,614.72	0.00	2,439.28	59.71
101-1171-72101	BONUS/SICK REDEMPTION	7,401.00	7,625.00	7,625.00	2,774.84	0.00	4,850.16	36.39
101-1171-72201	DEFINED CONTRIBUTION EXP	35,175.86	49,009.00	49,009.00	29,289.13	0.00	19,719.87	59.76
101-1171-72700	OFFICE SUPPLIES	6,203.13	10,000.00	10,000.00	4,796.27	5,691.76	(488.03)	104.88
101-1171-80100	CONTRACTUAL SERVICES	5,272.49	6,500.00	6,500.00	4,229.21	2,270.03	0.76	99.99
101-1171-80200	POSTAGE	2,039.69	5,000.00	5,000.00	1,367.57	0.00	3,632.43	27.35
101-1171-85300	TELEPHONE & RADIO	0.00	0.00	0.00	240.36	0.00	(240.36)	100.00
101-1171-95801	US CONFERENCE OF MAYORS	9,276.00	13,000.00	13,000.00	0.00	0.00	13,000.00	0.00
Net - Dept 1171 - MAYOR		(530,781.92)	(787,397.00)	(791,752.00)	(422,047.10)	(7,961.79)	(361,743.11)	
Dept 1209 - ASSESSING								
101-1209-70300	APPOINTED OFFICIAL	123,559.75	127,274.00	127,274.00	110,224.46	0.00	17,049.54	86.60
101-1209-70600	PERMANENT EMPLOYEES	738,973.84	850,008.00	850,008.00	631,214.57	0.00	218,793.43	74.26
101-1209-70703	CLERICAL CO-OP	15,390.00	50,000.00	50,000.00	8,786.50	0.00	41,213.50	17.57
101-1209-70900	OVERTIME	21,149.15	25,000.00	25,000.00	23,449.39	0.00	1,550.61	93.80
101-1209-71303	CLEAN/CLOTHING ALLOWANCE	3,800.00	4,200.00	4,200.00	4,375.00	0.00	(175.00)	104.17
101-1209-71500	SOCIAL SECURITY	70,644.25	84,065.00	84,065.00	61,259.29	0.00	22,805.71	72.87
101-1209-71900	EMPLOYEE INSURANCES	188,715.29	249,083.00	249,083.00	175,448.23	0.00	73,634.77	70.44
101-1209-71904	RETIREE HEALTH INSURANCE	137,022.00	137,022.00	137,022.00	114,190.00	0.00	22,832.00	83.34
101-1209-71905	H.S.A. EXPENSE	16,083.33	18,764.00	18,764.00	13,878.66	0.00	4,885.34	73.96
101-1209-71906	SUPL LIFE INSURANCE EXP	1,739.46	1,932.00	1,932.00	1,339.20	0.00	592.80	69.32
101-1209-72100	LONGEVITY	12,786.16	16,392.00	16,392.00	9,496.51	0.00	6,895.49	57.93
101-1209-72101	BONUS/SICK REDEMPTION	17,537.02	25,833.00	25,833.00	19,832.93	0.00	6,000.07	76.77
101-1209-72200	RETIREMENT FUND	311,090.00	286,390.00	286,390.00	238,660.00	0.00	47,730.00	83.33
101-1209-72201	DEFINED CONTRIBUTION EXP	80,416.15	93,801.00	93,801.00	69,394.33	0.00	24,406.67	73.98
101-1209-72700	OFFICE SUPPLIES	9,344.36	15,000.00	15,000.00	4,703.48	4,101.78	6,194.74	58.70
101-1209-80106	SOFTWARE SERVICES	34,045.67	41,000.00	41,000.00	33,836.97	2,547.96	4,615.07	88.74
101-1209-80200	POSTAGE	34,606.00	34,300.00	34,300.00	36,875.11	0.00	(2,575.11)	107.51
101-1209-80401	BOARD OF REVIEW	2,917.50	7,000.00	7,000.00	2,767.50	182.50	4,050.00	42.14
101-1209-82602	PROFESSIONAL SERVICES	79,382.00	190,000.00	190,000.00	30,615.44	113,266.50	46,118.06	75.73
101-1209-83300	TAX ROLL PREPARATION	15,968.94	35,000.00	35,000.00	12,604.65	2,394.29	20,001.06	42.85
101-1209-85300	TELEPHONE & RADIO	75.00	250.00	250.00	0.00	0.00	250.00	0.00
101-1209-86300	VEHICLE MAINTENANCE	1,127.03	2,000.00	2,000.00	667.95	445.25	886.80	55.66
101-1209-95800	MEMBERSHIPS & DUES	3,526.39	7,000.00	7,000.00	3,255.00	0.00	3,745.00	46.50
101-1209-98400	EQUIPMENT	28,165.00	0.00	0.00	0.00	0.00	0.00	0.00
Net - Dept 1209 - ASSESSING		(1,948,064.29)	(2,301,314.00)	(2,301,314.00)	(1,606,875.17)	(122,938.28)	(571,500.55)	
Dept 1210 - LEGAL								
101-1210-70300	APPOINTED OFFICIAL	134,609.97	138,656.00	138,656.00	121,715.05	0.00	16,940.95	87.78
101-1210-70601	ASSISTANT ATTORNEYS	515,077.41	553,962.00	553,962.00	361,343.73	0.00	192,618.27	65.23
101-1210-70602	CLERICAL	279,787.17	291,036.00	291,036.00	228,626.04	0.00	62,409.96	78.56
101-1210-70701	LAW CLERKS	35,069.53	50,000.00	50,000.00	34,414.96	0.00	15,585.04	68.83

REVENUE AND EXPENDITURE REPORT

PERIOD ENDING 04/30/2024

% Fiscal Year Completed: 83.33

GL NUMBER	DESCRIPTION	END BALANCE	2023-24		YTD BALANCE	ENCUMBERED	UNENCUMBERED	% BDGT
		06/30/2023	ORIGINAL	2023-24	04/30/2024			
		NORM (ABNORM)	BUDGET	AMENDED BUDGET	NORM (ABNORM)	YEAR-TO-DATE	BALANCE	USED
Fund 101 - GENERAL FUND								
101-1210-70703	CLERICAL CO-OP	25,330.20	100,000.00	100,000.00	41,264.54	0.00	58,735.46	41.26
101-1210-70900	OVERTIME	0.00	7,500.00	7,500.00	0.00	0.00	7,500.00	0.00
101-1210-71303	CLEAN/CLOTHING ALLOWANCE	3,000.00	3,500.00	3,500.00	3,733.33	0.00	(233.33)	106.67
101-1210-71500	SOCIAL SECURITY	78,385.44	91,846.00	91,846.00	63,422.71	0.00	28,423.29	69.05
101-1210-71900	EMPLOYEE INSURANCES	199,397.80	219,123.00	219,123.00	162,323.60	0.00	56,799.40	74.08
101-1210-71904	RETIREE HEALTH INSURANCE	91,348.00	91,348.00	91,348.00	76,120.00	0.00	15,228.00	83.33
101-1210-71905	H.S.A. EXPENSE	11,458.90	15,168.00	15,168.00	10,023.95	0.00	5,144.05	66.09
101-1210-71906	SUPPL LIFE INSURANCE EXP	2,591.44	2,334.00	2,334.00	1,748.64	0.00	585.36	74.92
101-1210-72100	LONGEVITY	18,579.26	23,753.00	23,753.00	20,638.95	0.00	3,114.05	86.89
101-1210-72101	BONUS/SICK REDEMPTION	25,115.83	32,049.00	32,049.00	21,163.78	0.00	10,885.22	66.04
101-1210-72200	RETIREMENT FUND	124,436.00	114,558.00	114,558.00	95,470.00	0.00	19,088.00	83.34
101-1210-72201	DEFINED CONTRIBUTION EXP	88,398.81	95,226.00	95,226.00	68,897.29	0.00	26,328.71	72.35
101-1210-72700	OFFICE SUPPLIES	10,099.55	24,000.00	24,000.00	20,843.34	2,680.18	476.48	98.01
101-1210-80100	CONTRACTUAL SERVICES	22,058.21	13,600.00	19,700.00	12,824.38	3,483.91	3,391.71	82.78
101-1210-80200	POSTAGE	727.35	1,700.00	1,700.00	616.17	0.00	1,083.83	36.25
101-1210-82600	LEGAL FEES	2,285.85	14,000.00	14,000.00	3,868.77	498.98	9,632.25	31.20
101-1210-86100	MILEAGE	254.14	700.00	700.00	0.00	0.00	700.00	0.00
101-1210-95800	MEMBERSHIPS & DUES	34,794.72	42,000.00	42,000.00	23,477.73	12,130.67	6,391.60	84.78
101-1210-98001	COMPUTER EQUIPMENT	3,117.13	0.00	0.00	0.00	0.00	0.00	0.00
Net - Dept 1210 - LEGAL		(1,705,922.71)	(1,926,059.00)	(1,932,159.00)	(1,372,536.96)	(18,793.74)	(540,828.30)	
Dept 1215 - CLERK								
101-1215-70200	ELECTED OFFICIALS	93,280.40	93,286.00	93,286.00	74,695.80	0.00	18,590.20	80.07
101-1215-70600	PERMANENT EMPLOYEES	373,058.15	426,694.00	426,694.00	324,434.51	0.00	102,259.49	76.03
101-1215-70703	CLERICAL CO-OP	88,236.24	221,600.00	281,754.00	102,482.90	0.00	179,271.10	36.37
101-1215-70900	OVERTIME	24,953.18	92,900.00	105,500.00	46,091.85	0.00	59,408.15	43.69
101-1215-71303	CLEAN/CLOTHING ALLOWANCE	2,156.69	2,450.00	2,450.00	2,100.00	0.00	350.00	85.71
101-1215-71500	SOCIAL SECURITY	45,937.04	66,312.00	76,616.00	47,628.45	0.00	28,987.55	62.17
101-1215-71900	EMPLOYEE INSURANCES	94,534.23	138,844.00	139,020.00	89,214.94	0.00	49,805.06	64.17
101-1215-71904	RETIREE HEALTH INSURANCE	68,511.00	68,511.00	68,511.00	57,090.00	0.00	11,421.00	83.33
101-1215-71905	H.S.A. EXPENSE	8,520.21	11,041.00	11,293.00	7,931.31	0.00	3,361.69	70.23
101-1215-71906	SUPPL LIFE INSURANCE EXP	782.00	1,190.00	1,190.00	869.88	0.00	320.12	73.10
101-1215-72100	LONGEVITY	8,638.00	10,163.00	10,163.00	10,160.82	0.00	2.18	99.98
101-1215-72101	BONUS/SICK REDEMPTION	8,352.36	19,620.00	19,620.00	10,703.16	0.00	8,916.84	54.55
101-1215-72200	RETIREMENT FUND	62,217.00	57,278.00	57,278.00	47,730.00	0.00	9,548.00	83.33
101-1215-72201	DEFINED CONTRIBUTION EXP	56,610.97	69,177.00	70,437.00	50,894.99	0.00	19,542.01	72.26
101-1215-72700	OFFICE SUPPLIES	14,543.32	40,000.00	43,350.00	10,211.81	9,473.01	23,665.18	45.41
101-1215-80100	CONTRACTUAL SERVICES	18,228.21	64,900.00	64,900.00	15,920.65	7,510.84	41,468.51	36.10
101-1215-80200	POSTAGE	49,200.75	114,000.00	144,000.00	48,828.71	0.00	95,171.29	33.91
101-1215-80400	ELECTION WAGES	175,170.00	629,425.00	691,355.00	269,032.45	0.00	422,322.55	38.91
101-1215-80600	ELECTION EXPENSE	121,767.00	398,900.00	551,800.00	241,771.51	154,909.73	155,118.76	71.89
101-1215-86300	VEHICLE MAINTENANCE	757.31	2,000.00	2,000.00	766.42	0.00	1,233.58	38.32
101-1215-90000	PRINTING & PUBLISHING	26,634.42	50,000.00	51,418.00	27,685.95	6,474.05	17,258.00	66.44
101-1215-93000	BUILDING MAINTENANCE	0.00	4,000.00	4,000.00	0.00	500.00	3,500.00	12.50
101-1215-98000	OFFICE EQUIPMENT	0.00	36,945.00	36,945.00	7,762.81	0.00	29,182.19	21.01
Net - Dept 1215 - CLERK		(1,342,088.48)	(2,619,236.00)	(2,953,580.00)	(1,494,008.92)	(178,867.63)	(1,280,703.45)	
Dept 1220 - HUMAN RESOURCES								
101-1220-70600	PERMANENT EMPLOYEES	542,344.95	620,149.00	620,149.00	422,750.15	0.00	197,398.85	68.17
101-1220-70703	CLERICAL CO-OP	34,074.81	75,000.00	75,000.00	0.00	0.00	75,000.00	0.00
101-1220-70900	OVERTIME	10,739.45	25,000.00	25,000.00	12,222.70	0.00	12,777.30	48.89
101-1220-71303	CLEAN/CLOTHING ALLOWANCE	2,350.00	2,800.00	2,800.00	2,800.00	0.00	0.00	100.00
101-1220-71500	SOCIAL SECURITY	47,341.45	58,237.00	58,237.00	35,568.43	0.00	22,668.57	61.08

REVENUE AND EXPENDITURE REPORT

PERIOD ENDING 04/30/2024

% Fiscal Year Completed: 83.33

GL NUMBER	DESCRIPTION	END BALANCE	2023-24		YTD BALANCE	ENCUMBERED	UNENCUMBERED	% BDGT
		06/30/2023	ORIGINAL	2023-24	04/30/2024			
		NORM (ABNORM)	BUDGET	AMENDED BUDGET	NORM (ABNORM)	YEAR-TO-DATE	BALANCE	USED
Fund 101 - GENERAL FUND								
101-1220-71900	EMPLOYEE INSURANCES	91,647.56	158,592.00	158,592.00	87,669.28	0.00	70,922.72	55.28
101-1220-71904	RETIREE HEALTH INSURANCE	91,348.00	91,348.00	91,348.00	76,120.00	0.00	15,228.00	83.33
101-1220-71905	H.S.A. EXPENSE	9,586.20	11,182.00	11,182.00	8,439.19	0.00	2,742.81	75.47
101-1220-71906	SUPPL LIFE INSURANCE EXP	343.76	600.00	600.00	329.70	0.00	270.30	54.95
101-1220-72100	LONGEVITY	11,837.62	14,138.00	14,138.00	9,987.24	0.00	4,150.76	70.64
101-1220-72101	BONUS/SICK REDEMPTION	21,401.17	24,056.00	24,056.00	19,233.07	0.00	4,822.93	79.95
101-1220-72200	RETIREMENT FUND	124,436.00	114,558.00	114,558.00	95,470.00	0.00	19,088.00	83.34
101-1220-72201	DEFINED CONTRIBUTION EXP	59,674.78	68,617.00	68,617.00	47,847.21	0.00	20,769.79	69.73
101-1220-72501	FEES & PER DIEM	4,450.00	4,000.00	4,000.00	1,050.00	0.00	2,950.00	26.25
101-1220-72700	OFFICE SUPPLIES	8,939.42	14,500.00	14,500.00	7,437.15	3,520.05	3,542.80	75.57
101-1220-80100	CONTRACTUAL SERVICES	76,556.73	198,800.00	198,800.00	52,375.22	42,973.34	103,451.44	47.96
101-1220-80114	ARBITRATION EXPENSE	5,880.78	50,000.00	50,000.00	2,953.84	0.00	47,046.16	5.91
101-1220-80127	CONTRACTUAL SVCS - E.A.C.	23,421.30	27,000.00	27,000.00	0.00	0.00	27,000.00	0.00
101-1220-80200	POSTAGE	1,867.75	2,000.00	2,000.00	1,197.14	171.14	631.72	68.41
101-1220-82800	MEDICAL SERVICES	95,417.00	160,000.00	160,000.00	78,952.00	0.00	81,048.00	49.35
101-1220-90000	PRINTING & PUBLISHING	49,493.36	79,000.00	79,000.00	27,388.08	30,856.32	20,755.60	73.73
101-1220-95800	MEMBERSHIPS & DUES	753.00	1,500.00	1,500.00	0.00	0.00	1,500.00	0.00
101-1220-98001	COMPUTER EQUIPMENT	0.00	15,000.00	15,000.00	459.12	0.00	14,540.88	3.06
Net - Dept 1220 - HUMAN RESOURCES		(1,313,905.09)	(1,816,077.00)	(1,816,077.00)	(990,249.52)	(77,520.85)	(748,306.63)	
Dept 1221 - CIVIL SERVICE-POL & FIRE								
101-1221-72501	FEES & PER DIEM	1,250.00	2,000.00	2,000.00	550.00	0.00	1,450.00	27.50
101-1221-72700	OFFICE SUPPLIES	598.51	700.00	700.00	0.00	700.00	0.00	100.00
101-1221-74000	OPERATING SUPPLIES	1,000.00	6,000.00	6,000.00	3,250.00	750.00	2,000.00	66.67
101-1221-80100	CONTRACTUAL SERVICES	8,951.94	20,000.00	20,000.00	3,853.81	10,146.19	6,000.00	70.00
101-1221-80200	POSTAGE	30.75	200.00	200.00	52.94	0.00	147.06	26.47
Net - Dept 1221 - CIVIL SERVICE-POL & FIRE		(11,831.20)	(28,900.00)	(28,900.00)	(7,706.75)	(11,596.19)	(9,597.06)	
Dept 1223 - CONTROLLER								
101-1223-70300	APPOINTED OFFICIAL	127,533.65	135,085.00	135,085.00	108,165.64	0.00	26,919.36	80.07
101-1223-70600	PERMANENT EMPLOYEES	876,452.09	1,075,738.00	1,075,738.00	788,054.02	0.00	287,683.98	73.26
101-1223-70703	CLERICAL CO-OP	0.00	40,000.00	40,000.00	0.00	0.00	40,000.00	0.00
101-1223-70900	OVERTIME	10,450.05	20,000.00	20,000.00	15,474.50	0.00	4,525.50	77.37
101-1223-71303	CLEAN/CLOTHING ALLOWANCE	3,800.00	4,550.00	4,550.00	3,850.00	0.00	700.00	84.62
101-1223-71500	SOCIAL SECURITY	84,210.08	104,195.00	104,195.00	75,301.83	0.00	28,893.17	72.27
101-1223-71900	EMPLOYEE INSURANCES	187,435.80	266,106.00	266,106.00	205,691.78	0.00	60,414.22	77.30
101-1223-71904	RETIREE HEALTH INSURANCE	114,185.00	114,185.00	114,185.00	95,150.00	0.00	19,035.00	83.33
101-1223-71905	H.S.A. EXPENSE	9,903.06	16,172.00	16,172.00	9,584.16	0.00	6,587.84	59.26
101-1223-71906	SUPPL LIFE INSURANCE EXP	3,217.92	4,430.00	4,430.00	2,860.42	0.00	1,569.58	64.57
101-1223-72100	LONGEVITY	27,155.55	34,548.00	34,548.00	20,865.08	0.00	13,682.92	60.39
101-1223-72101	BONUS/SICK REDEMPTION	48,800.77	51,919.00	51,919.00	42,011.51	0.00	9,907.49	80.92
101-1223-72200	RETIREMENT FUND	124,436.00	114,558.00	114,558.00	95,470.00	0.00	19,088.00	83.34
101-1223-72201	DEFINED CONTRIBUTION EXP	84,716.50	106,952.00	106,952.00	76,872.26	0.00	30,079.74	71.88
101-1223-72700	OFFICE SUPPLIES	10,434.27	25,000.00	25,000.00	18,420.78	8,576.31	(1,997.09)	107.99
101-1223-80100	CONTRACTUAL SERVICES	1,092.48	17,000.00	17,000.00	4,276.73	478.56	12,244.71	27.97
101-1223-80200	POSTAGE	803.02	1,000.00	1,000.00	708.40	0.00	291.60	70.84
Net - Dept 1223 - CONTROLLER		(1,714,626.24)	(2,131,438.00)	(2,131,438.00)	(1,562,757.11)	(9,054.87)	(559,626.02)	
Dept 1237 - CITY RETIREMENT								
101-1237-70600	PERMANENT EMPLOYEES	156,946.07	169,016.00	169,016.00	135,313.81	0.00	33,702.19	80.06
101-1237-70700	TEMPORARY EMPLOYEES	2,467.50	10,000.00	10,000.00	2,485.00	0.00	7,515.00	24.85

REVENUE AND EXPENDITURE REPORT

PERIOD ENDING 04/30/2024

% Fiscal Year Completed: 83.33

GL NUMBER	DESCRIPTION	END BALANCE	2023-24		YTD BALANCE	ENCUMBERED	UNENCUMBERED	% BDGT
		06/30/2023	ORIGINAL	2023-24	04/30/2024			
		NORM (ABNORM)	BUDGET	AMENDED BUDGET	NORM (ABNORM)	YEAR-TO-DATE	BALANCE	USED
Fund 101 - GENERAL FUND								
101-1237-70900	OVERTIME	9,043.27	10,000.00	10,000.00	8,334.83	0.00	1,665.17	83.35
101-1237-71302	EDUCATION ALLOWANCE	1,400.00	1,500.00	1,500.00	1,500.00	0.00	0.00	100.00
101-1237-71303	CLEAN/CLOTHING ALLOWANCE	650.00	700.00	700.00	700.00	0.00	0.00	100.00
101-1237-71500	SOCIAL SECURITY	13,662.46	15,745.00	15,745.00	12,218.12	0.00	3,526.88	77.60
101-1237-71900	EMPLOYEE INSURANCES	31,098.35	43,498.00	43,498.00	30,772.70	0.00	12,725.30	70.75
101-1237-71902	RETIREE INSURANCES	7,745,001.08	8,500,000.00	8,500,000.00	6,871,745.99	0.00	1,628,254.01	80.84
101-1237-71904	RETIREE HEALTH INSURANCE	45,674.00	45,674.00	45,674.00	38,060.00	0.00	7,614.00	83.33
101-1237-71905	H.S.A. EXPENSE	2,074.43	2,265.00	2,265.00	1,841.96	0.00	423.04	81.32
101-1237-71906	SUPPL LIFE INSURANCE EXP	372.00	480.00	480.00	310.00	0.00	170.00	64.58
101-1237-72100	LONGEVITY	6,800.00	6,800.00	6,800.00	6,800.00	0.00	0.00	100.00
101-1237-72101	BONUS/SICK REDEMPTION	4,736.18	7,771.00	7,771.00	7,196.68	0.00	574.32	92.61
101-1237-72201	DEFINED CONTRIBUTION EXP	17,938.28	19,579.00	19,579.00	15,984.64	0.00	3,594.36	81.64
101-1237-72700	OFFICE SUPPLIES	0.00	6,100.00	6,100.00	0.00	0.00	6,100.00	0.00
101-1237-80200	POSTAGE	744.05	2,000.00	2,000.00	1,637.89	0.00	362.11	81.89
101-1237-85300	TELEPHONE & RADIO	570.00	1,000.00	1,000.00	446.87	0.00	553.13	44.69
101-1237-96904	REIMB ACT 55	(177,031.57)	(208,917.00)	(208,917.00)	(98,531.46)	0.00	(110,385.54)	47.16
101-1237-96905	VEBA REIMBURSEMENT	(8,899,273.20)	(9,783,211.00)	(9,783,211.00)	(4,696,093.05)	0.00	(5,087,117.95)	48.00
101-1237-96910	MEDICARE REIMBURSEMENT	1,037,127.10	1,150,000.00	1,150,000.00	495,242.80	0.00	654,757.20	43.06
Net - Dept 1237 - CITY RETIREMENT		0.00	0.00	0.00	(2,835,966.78)	0.00	2,835,966.78	
Dept 1238 - POLICE & FIRE RETIREMENT								
101-1238-70600	PERMANENT EMPLOYEES	214,732.34	246,522.00	246,522.00	197,394.23	0.00	49,127.77	80.07
101-1238-70700	TEMPORARY EMPLOYEES	9,053.50	20,000.00	20,000.00	0.00	0.00	20,000.00	0.00
101-1238-70900	OVERTIME	13,938.25	5,200.00	17,200.00	12,327.08	0.00	4,872.92	71.67
101-1238-71302	EDUCATION ALLOWANCE	1,500.00	2,500.00	2,500.00	2,500.00	0.00	0.00	100.00
101-1238-71303	CLEAN/CLOTHING ALLOWANCE	650.00	1,050.00	1,050.00	1,050.00	0.00	0.00	100.00
101-1238-71500	SOCIAL SECURITY	19,181.10	22,450.00	22,450.00	17,014.13	0.00	5,435.87	75.79
101-1238-71900	EMPLOYEE INSURANCES	54,432.99	65,158.00	65,158.00	55,102.03	0.00	10,055.97	84.57
101-1238-71902	RETIREE INSURANCES	9,232,624.77	10,500,000.00	10,500,000.00	8,790,029.54	0.00	1,709,970.46	83.71
101-1238-71904	RETIREE HEALTH INSURANCE	45,674.00	45,674.00	45,674.00	38,060.00	0.00	7,614.00	83.33
101-1238-71905	H.S.A. EXPENSE	1,031.23	1,670.00	1,670.00	1,272.92	0.00	397.08	76.22
101-1238-71906	SUPPL LIFE INSURANCE EXP	514.20	756.00	756.00	457.60	0.00	298.40	60.53
101-1238-72100	LONGEVITY	10,200.00	6,800.00	10,200.00	10,200.00	0.00	0.00	100.00
101-1238-72101	BONUS/SICK REDEMPTION	5,746.10	11,335.00	11,335.00	4,509.48	0.00	6,825.52	39.78
101-1238-72200	RETIREMENT FUND	62,217.00	57,278.00	57,278.00	47,730.00	0.00	9,548.00	83.33
101-1238-72201	DEFINED CONTRIBUTION EXP	34,437.26	37,099.00	37,099.00	31,014.84	0.00	6,084.16	83.60
101-1238-72700	OFFICE SUPPLIES	0.00	5,218.00	5,218.00	0.00	0.00	5,218.00	0.00
101-1238-80200	POSTAGE	796.09	5,016.00	5,016.00	688.71	0.00	4,327.29	13.73
101-1238-85300	TELEPHONE & RADIO	427.52	1,000.00	1,000.00	335.15	0.00	664.85	33.52
101-1238-96904	REIMB ACT 55	(474,531.58)	(534,726.00)	(550,126.00)	(248,771.85)	0.00	(301,354.15)	45.22
101-1238-96905	VEBA REIMBURSEMENT	(10,160,185.17)	(11,500,000.00)	(11,500,000.00)	(5,630,186.57)	0.00	(5,869,813.43)	48.96
101-1238-96910	MEDICARE REIMBURSEMENT	927,560.40	1,000,000.00	1,000,000.00	494,564.20	0.00	505,435.80	49.46
Net - Dept 1238 - POLICE & FIRE RETIREMENT		0.00	0.00	0.00	(3,825,291.49)	0.00	3,825,291.49	
Dept 1253 - TREASURER								
101-1253-70200	ELECTED OFFICIALS	93,280.40	93,286.00	93,286.00	74,695.80	0.00	18,590.20	80.07
101-1253-70600	PERMANENT EMPLOYEES	514,142.60	615,467.00	615,467.00	457,243.21	0.00	158,223.79	74.29
101-1253-70703	CLERICAL CO-OP	8,652.00	21,000.00	21,000.00	12,232.00	0.00	8,768.00	58.25
101-1253-70900	OVERTIME	442.23	4,000.00	4,000.00	226.33	0.00	3,773.67	5.66
101-1253-71303	CLEAN/CLOTHING ALLOWANCE	2,350.00	2,800.00	2,800.00	3,004.17	0.00	(204.17)	107.29
101-1253-71500	SOCIAL SECURITY	49,534.98	59,541.00	59,541.00	44,220.30	0.00	15,320.70	74.27
101-1253-71900	EMPLOYEE INSURANCES	149,055.63	194,531.00	194,531.00	153,660.26	0.00	40,870.74	78.99
101-1253-71904	RETIREE HEALTH INSURANCE	114,185.00	114,185.00	114,185.00	95,150.00	0.00	19,035.00	83.33

REVENUE AND EXPENDITURE REPORT

PERIOD ENDING 04/30/2024

% Fiscal Year Completed: 83.33

GL NUMBER	DESCRIPTION	END BALANCE	2023-24		YTD BALANCE	ENCUMBERED	UNENCUMBERED	% BDGT
		06/30/2023	ORIGINAL	2023-24	04/30/2024			
		NORM (ABNORM)	BUDGET	AMENDED BUDGET	NORM (ABNORM)	YEAR-TO-DATE	BALANCE	USED
Fund 101 - GENERAL FUND								
101-1253-71905	H.S.A. EXPENSE	5,706.46	7,540.00	7,540.00	5,311.86	0.00	2,228.14	70.45
101-1253-71906	SUPPL LIFE INSURANCE EXP	383.04	596.00	596.00	339.60	0.00	256.40	56.98
101-1253-72100	LONGEVITY	16,154.68	19,632.00	19,632.00	15,016.67	0.00	4,615.33	76.49
101-1253-72101	BONUS/SICK REDEMPTION	18,461.40	22,007.00	22,007.00	20,111.18	0.00	1,895.82	91.39
101-1253-72200	RETIREMENT FUND	124,436.00	114,558.00	114,558.00	95,470.00	0.00	19,088.00	83.34
101-1253-72201	DEFINED CONTRIBUTION EXP	63,507.38	84,652.00	84,652.00	56,259.91	0.00	28,392.09	66.46
101-1253-72700	OFFICE SUPPLIES	9,635.52	21,150.00	21,150.00	10,447.00	3,097.35	7,605.65	64.04
101-1253-80100	CONTRACTUAL SERVICES	32,773.34	45,545.00	45,545.00	30,797.66	4,122.00	10,625.34	76.67
101-1253-80200	POSTAGE	58,953.59	84,000.00	84,000.00	69,442.86	0.00	14,557.14	82.67
101-1253-83600	TAX STATEMENT PREPARATION	14,768.50	16,000.00	16,000.00	14,494.26	1,256.28	249.46	98.44
101-1253-98000	OFFICE EQUIPMENT	26,029.78	14,000.00	14,000.00	12,749.10	0.00	1,250.90	91.07
Net - Dept 1253 - TREASURER		(1,302,452.53)	(1,534,490.00)	(1,534,490.00)	(1,170,872.17)	(8,475.63)	(355,142.20)	
Dept 1258 - INFORMATION SYSTEMS								
101-1258-70600	PERMANENT EMPLOYEES	327,346.99	445,133.00	445,133.00	296,054.53	0.00	149,078.47	66.51
101-1258-70700	TEMPORARY EMPLOYEES	0.00	7,500.00	7,500.00	0.00	0.00	7,500.00	0.00
101-1258-70900	OVERTIME	16,763.04	15,000.00	15,000.00	5,157.50	0.00	9,842.50	34.38
101-1258-71303	CLEAN/CLOTHING ALLOWANCE	1,050.00	1,750.00	1,750.00	1,400.00	0.00	350.00	80.00
101-1258-71500	SOCIAL SECURITY	28,214.60	38,481.00	38,481.00	24,915.88	0.00	13,565.12	64.75
101-1258-71900	EMPLOYEE INSURANCES	64,014.46	108,962.00	108,962.00	64,640.54	0.00	44,321.46	59.32
101-1258-71904	RETIREE HEALTH INSURANCE	68,511.00	68,511.00	68,511.00	57,090.00	0.00	11,421.00	83.33
101-1258-71905	H.S.A. EXPENSE	3,564.98	5,859.00	5,859.00	3,266.13	0.00	2,592.87	55.75
101-1258-71906	SUPPL LIFE INSURANCE EXP	541.44	840.00	840.00	461.00	0.00	379.00	54.88
101-1258-72100	LONGEVITY	11,552.00	13,094.00	13,094.00	11,652.30	0.00	1,441.70	88.99
101-1258-72101	BONUS/SICK REDEMPTION	16,458.04	20,467.00	20,467.00	13,692.36	0.00	6,774.64	66.90
101-1258-72201	DEFINED CONTRIBUTION EXP	42,787.62	55,556.00	55,556.00	37,364.31	0.00	18,191.69	67.26
101-1258-74000	OPERATING SUPPLIES	2,358.25	23,740.00	23,740.00	4,339.78	7,951.93	11,448.29	51.78
101-1258-80100	CONTRACTUAL SERVICES	211,675.75	452,800.00	482,000.00	198,880.91	22,520.72	260,598.37	45.93
101-1258-80106	SOFTWARE SERVICES	26,045.60	27,500.00	27,500.00	305.60	0.00	27,194.40	1.11
101-1258-98001	COMPUTER EQUIPMENT	84,637.05	250,000.00	250,000.00	0.00	0.00	250,000.00	0.00
Net - Dept 1258 - INFORMATION SYSTEMS		(905,520.82)	(1,535,193.00)	(1,564,393.00)	(719,220.84)	(30,472.65)	(814,699.51)	
Dept 1265 - BUILDING MAINTENANCE								
101-1265-70501	SUPERINTENDENT	92,885.20	105,410.00	105,410.00	80,722.20	0.00	24,687.80	76.58
101-1265-70600	PERMANENT EMPLOYEES	774,952.27	1,004,631.00	1,004,631.00	633,771.00	0.00	370,860.00	63.08
101-1265-70900	OVERTIME	4,323.88	36,000.00	36,000.00	4,712.05	0.00	31,287.95	13.09
101-1265-71303	CLEAN/CLOTHING ALLOWANCE	4,591.11	7,000.00	7,000.00	6,125.00	0.00	875.00	87.50
101-1265-71500	SOCIAL SECURITY	68,160.08	92,253.00	92,253.00	56,210.57	0.00	36,042.43	60.93
101-1265-71900	EMPLOYEE INSURANCES	243,625.59	468,961.00	468,961.00	254,952.32	0.00	214,008.68	54.37
101-1265-71904	RETIREE HEALTH INSURANCE	159,859.00	159,859.00	159,859.00	133,220.00	0.00	26,639.00	83.34
101-1265-71905	H.S.A. EXPENSE	12,896.49	18,470.00	18,470.00	11,057.26	0.00	7,412.74	59.87
101-1265-71906	SUPPL LIFE INSURANCE EXP	2,943.60	5,088.00	5,088.00	2,393.51	0.00	2,694.49	47.04
101-1265-72100	LONGEVITY	14,710.24	26,805.00	26,805.00	9,311.60	0.00	17,493.40	34.74
101-1265-72101	BONUS/SICK REDEMPTION	11,220.84	25,705.00	25,705.00	11,131.57	0.00	14,573.43	43.31
101-1265-72200	RETIREMENT FUND	373,308.00	343,668.00	343,668.00	286,390.00	0.00	57,278.00	83.33
101-1265-72201	DEFINED CONTRIBUTION EXP	87,829.00	127,091.00	127,091.00	72,663.66	0.00	54,427.34	57.17
101-1265-74000	OPERATING SUPPLIES	48,748.53	103,040.00	103,040.00	39,608.99	31,670.00	31,761.01	69.18
101-1265-77600	MAINTENANCE SUPPLIES	51,638.20	114,000.00	114,000.00	25,316.98	45,332.47	43,350.55	61.97
101-1265-80110	CONTRACTUAL SERVICES-BLDG MNT	145,911.12	214,650.00	214,650.00	128,856.14	54,262.73	31,531.13	85.31
101-1265-85300	TELEPHONE & RADIO	421.20	1,110.00	1,110.00	0.00	0.00	1,110.00	0.00
101-1265-86300	VEHICLE MAINTENANCE	6,343.60	10,000.00	10,000.00	3,651.84	0.00	6,348.16	36.52
101-1265-98100	VEHICLES	48,041.00	50,000.00	50,000.00	48,932.61	0.00	1,067.39	97.87
101-1265-98400	EQUIPMENT	0.00	50,000.00	50,000.00	0.00	0.00	50,000.00	0.00

REVENUE AND EXPENDITURE REPORT

PERIOD ENDING 04/30/2024

% Fiscal Year Completed: 83.33

GL NUMBER	DESCRIPTION	END BALANCE	2023-24		YTD BALANCE	ENCUMBERED	UNENCUMBERED	% BDGT
		06/30/2023	ORIGINAL	2023-24	04/30/2024			
		NORM (ABNORM)	BUDGET	AMENDED BUDGET	NORM (ABNORM)	YEAR-TO-DATE	BALANCE	USED
Fund 101 - GENERAL FUND								
101-1265-98408	EQUIPMENT - MAINTENANCE	35,997.78	0.00	0.00	0.00	0.00	0.00	0.00
Net - Dept 1265 - BUILDING MAINTENANCE		(2,188,406.73)	(2,963,741.00)	(2,963,741.00)	(1,809,027.30)	(131,265.20)	(1,023,448.50)	
Dept 1294 - ADMIN UNALLOCATED EXPENSE								
101-1294-71302	EDUCATION ALLOWANCE	63,033.33	70,000.00	70,000.00	63,916.66	0.00	6,083.34	91.31
101-1294-80104	CONT SVC- DATA CONVERSION	80,500.00	0.00	774,965.00	229,520.00	545,445.00	0.00	100.00
101-1294-80105	INDEPENDENT AUDIT	91,500.00	99,400.00	99,400.00	94,400.00	0.00	5,000.00	94.97
101-1294-80194	TAX REVERTED PROPERTY	16,372.57	850,000.00	850,000.00	6,538.33	0.00	843,461.67	0.77
101-1294-80301	UNEMPLOYMENT COSTS	0.00	1,250.00	1,250.00	13.91	0.00	1,236.09	1.11
101-1294-82602	PROFESSIONAL SERVICES	639,985.04	522,273.00	710,273.00	350,203.70	122,342.38	237,726.92	66.53
101-1294-85300	TELEPHONE & RADIO	29,176.92	80,000.00	80,000.00	23,475.75	0.00	56,524.25	29.34
101-1294-86400	CONFERENCES & WORKSHOPS	38,977.29	40,000.00	40,000.00	40,978.55	0.00	(978.55)	102.45
101-1294-86401	INCOMING MAYOR TRANSITION EXPE	0.00	15,000.00	15,000.00	15,000.00	0.00	0.00	100.00
101-1294-91000	INSURANCE & BONDS	2,877,281.72	3,300,000.00	3,300,000.00	3,285,772.03	4,323.46	9,904.51	99.70
101-1294-91200	GRIEVANCE SETTLEMENTS	250,000.00	250,000.00	250,000.00	250,000.00	0.00	0.00	100.00
101-1294-91304	401(A) BOARD OPERATING EX	55,412.50	57,000.00	58,675.00	42,912.38	0.00	15,762.62	73.14
101-1294-92001	PUBLIC UTILITIES - COURT	10,409.87	15,000.00	15,000.00	7,957.10	0.00	7,042.90	53.05
101-1294-92002	PUB UTILITIES-CIVIC CENTR	288,609.09	295,000.00	295,000.00	217,258.59	0.00	77,741.41	73.65
101-1294-96701	TRANSFER TO REVOLVING FND	500,000.00	0.00	0.00	0.00	0.00	0.00	0.00
101-1294-98500	ARPA EXPENDITURES	37,638.50	0.00	311,079.00	14,579.00	0.00	296,500.00	4.69
Net - Dept 1294 - ADMIN UNALLOCATED EXPENSE		(4,978,896.83)	(5,594,923.00)	(6,870,642.00)	(4,642,526.00)	(672,110.84)	(1,556,005.16)	
Dept 1301 - POLICE DEPARTMENT								
101-1301-70300	APPOINTED OFFICIAL	138,515.43	142,680.00	154,680.00	126,300.83	0.00	28,379.17	81.65
101-1301-70602	CLERICAL	1,999,304.90	2,888,992.00	2,879,950.00	1,819,549.83	0.00	1,060,400.17	63.18
101-1301-70605	POLICEMEN	19,376,646.41	21,883,563.00	21,202,063.00	16,558,780.45	0.00	4,643,282.55	78.10
101-1301-70703	CLERICAL CO-OP	108,307.30	96,824.00	105,866.00	68,614.13	0.00	37,251.87	64.81
101-1301-70707	CROSSING GUARDS	246,889.80	330,000.00	330,000.00	216,670.50	0.00	113,329.50	65.66
101-1301-70902	OVERTIME - CLERICAL	192,801.84	151,913.00	151,913.00	89,518.68	0.00	62,394.32	58.93
101-1301-70905	OVERTIME - POLICEMEN	1,395,127.60	1,213,795.00	1,863,795.00	1,406,923.07	0.00	456,871.93	75.49
101-1301-71000	SHIFT PREMIUM	307,679.76	325,000.00	325,000.00	269,172.49	0.00	55,827.51	82.82
101-1301-71301	GUN ALLOWANCE	213,167.03	229,900.00	229,900.00	5,676.59	0.00	224,223.41	2.47
101-1301-71302	EDUCATION ALLOWANCE	54,066.67	59,300.00	59,300.00	56,066.67	0.00	3,233.33	94.55
101-1301-71303	CLEAN/CLOTHING ALLOWANCE	119,017.01	160,450.00	160,450.00	142,936.31	0.00	17,513.69	89.08
101-1301-71500	SOCIAL SECURITY	541,867.60	652,342.00	652,342.00	458,854.19	0.00	193,487.81	70.34
101-1301-71700	HOLIDAY PAY	1,224,681.27	1,450,123.00	1,450,123.00	572,765.66	0.00	877,357.34	39.50
101-1301-71900	EMPLOYEE INSURANCES	4,886,486.03	6,643,673.00	6,636,673.00	4,483,611.70	0.00	2,153,061.30	67.56
101-1301-71904	RETIREE HEALTH INSURANCE	6,318,738.00	5,170,473.00	5,170,473.00	4,308,730.00	0.00	861,743.00	83.33
101-1301-71905	H.S.A. EXPENSE	359,528.29	455,865.00	455,865.00	319,933.54	0.00	135,931.46	70.18
101-1301-71906	SUPPL LIFE INSURANCE EXP	10,653.31	11,922.00	11,922.00	9,369.38	0.00	2,552.62	78.59
101-1301-72100	LONGEVITY	312,311.69	355,996.00	355,996.00	294,057.64	0.00	61,938.36	82.60
101-1301-72101	BONUS/SICK REDEMPTION	25,152.29	47,548.00	47,548.00	26,284.00	0.00	21,264.00	55.28
101-1301-72200	RETIREMENT FUND	9,654,958.00	9,837,412.00	9,837,412.00	8,197,840.00	0.00	1,639,572.00	83.33
101-1301-72201	DEFINED CONTRIBUTION EXP	211,199.60	299,869.00	299,869.00	186,425.47	0.00	113,443.53	62.17
101-1301-72401	UNIFORMS	231,252.41	265,800.00	265,800.00	167,297.00	85,202.08	13,300.92	95.00
101-1301-72700	OFFICE SUPPLIES	52,970.98	157,639.00	157,639.00	47,626.63	21,920.44	88,091.93	44.12
101-1301-74000	OPERATING SUPPLIES	83,985.92	128,049.00	128,049.00	85,524.61	37,584.77	4,939.62	96.14
101-1301-74005	2020 DOJ CORONAVIRUS CESH	53,850.33	0.00	0.00	0.00	0.00	0.00	0.00
101-1301-75100	GAS & OIL	390,536.56	500,000.00	500,000.00	254,092.55	0.00	245,907.45	50.82
101-1301-80100	CONTRACTUAL SERVICES	860,330.15	703,461.00	732,961.00	408,105.23	97,414.04	227,441.73	68.97
101-1301-80200	POSTAGE	5,800.61	7,000.00	7,000.00	4,628.83	0.00	2,371.17	66.13
101-1301-81001	SPECIAL INVESTIGATIONS	8,000.00	10,000.00	10,000.00	8,000.00	0.00	2,000.00	80.00
101-1301-81200	PRISONER FOOD	23,045.58	60,000.00	60,000.00	31,311.88	11,013.28	17,674.84	70.54

REVENUE AND EXPENDITURE REPORT

PERIOD ENDING 04/30/2024

% Fiscal Year Completed: 83.33

GL NUMBER	DESCRIPTION	END BALANCE	2023-24		YTD BALANCE	ENCUMBERED	UNENCUMBERED	% BDGT
		06/30/2023	ORIGINAL	2023-24	04/30/2024			
		NORM (ABNORM)	BUDGET	AMENDED BUDGET	NORM (ABNORM)	YEAR-TO-DATE	BALANCE	USED
Fund 101 - GENERAL FUND								
101-1301-81300	CRIME PREVENTION	4,116.30	25,000.00	25,000.00	4,615.70	0.00	20,384.30	18.46
101-1301-82401	INSTRUCTION	61,917.37	97,715.00	97,715.00	71,236.75	15,850.00	10,628.25	89.12
101-1301-82402	911 DISPATCH TRAINING EXP	46,283.50	37,500.00	37,500.00	3,536.00	2,750.00	31,214.00	16.76
101-1301-85300	TELEPHONE & RADIO	112,475.80	276,622.00	277,622.00	24,934.34	18,224.75	234,462.91	15.55
101-1301-86300	VEHICLE MAINTENANCE	26,275.69	26,250.00	33,750.00	15,784.89	10,882.70	7,082.41	79.02
101-1301-88001	COMMUNITY PROMOTION/OUTREACH F	8,441.91	8,500.00	8,500.00	2,188.28	450.00	5,861.72	31.04
101-1301-88002	EXPLORERS	4,967.00	5,000.00	5,000.00	0.00	5,000.00	0.00	100.00
101-1301-88003	YOUTH ATHLETIC LEAGUE	10,000.00	10,000.00	10,000.00	8,348.25	0.00	1,651.75	83.48
101-1301-88004	WELLNESS PROGRAM	0.00	8,000.00	8,000.00	0.00	0.00	8,000.00	0.00
101-1301-88012	CERT EXPENSES	7,454.66	7,500.00	7,500.00	400.10	0.00	7,099.90	5.33
101-1301-92000	PUBLIC UTILITIES	212,220.25	0.00	225,000.00	159,764.94	0.00	65,235.06	71.01
101-1301-93000	BUILDING MAINTENANCE	73,793.76	62,450.00	112,450.00	53,149.63	47,673.90	11,626.47	89.66
101-1301-97400	CAPITAL IMPROVEMENTS	350,801.08	690,000.00	768,033.00	102,357.50	0.00	665,675.50	13.33
101-1301-98000	OFFICE EQUIPMENT	14,166.42	41,050.00	41,050.00	0.00	0.00	41,050.00	0.00
101-1301-98402	POLICE EQUIPMENT	345,796.68	846,723.00	1,094,258.00	636,591.75	77,878.40	379,787.85	65.29
101-1301-98414	911 EQUIPMENT EXPENSE	13,279.35	5,000.00	14,641.00	13,679.22	840.00	121.78	99.17
101-1301-98479	2022 JAG GRANT EXPENSE	68,522.76	0.00	12,924.00	0.00	0.00	12,924.00	0.00
101-1301-98486	2023 JAG GRANT EXPENSE	0.00	0.00	86,318.00	45,050.84	14,204.01	27,063.15	68.65
101-1301-98501	2020 BYRNE JAG EXPENSE	12,607.15	0.00	0.00	0.00	0.00	0.00	0.00
101-1301-98503	2019 BYRNE JAG EXPENSES - SIMU	9,775.00	0.00	0.00	0.00	0.00	0.00	0.00
101-1301-98504	2021 BYRNE JAG EXPENSE	0.00	0.00	12,813.00	0.00	0.00	12,813.00	0.00
101-1301-99400	LEASE PRINCIPAL	94,741.44	94,742.00	94,742.00	94,741.44	0.00	0.56	100.00
Net - Dept 1301 - POLICE DEPARTMENT		(50,884,508.49)	(56,481,641.00)	(57,215,405.00)	(41,861,047.49)	(446,888.37)	(14,907,469.14)	
Dept 1311 - CRIME COMMISSION								
101-1311-72700	OFFICE SUPPLIES	299.04	1,000.00	1,000.00	0.00	300.00	700.00	30.00
101-1311-80100	CONTRACTUAL SERVICES	2,100.00	1,800.00	1,800.00	1,200.00	600.00	0.00	100.00
101-1311-88001	COMMUNITY PROMOTION/OUTREACH F	9,780.31	10,000.00	10,000.00	3,022.57	5,492.63	1,484.80	85.15
101-1311-92000	PUBLIC UTILITIES	2,171.06	2,000.00	2,000.00	1,267.04	0.00	732.96	63.35
Net - Dept 1311 - CRIME COMMISSION		(14,350.41)	(14,800.00)	(14,800.00)	(5,489.61)	(6,392.63)	(2,917.76)	
Dept 1336 - FIRE DEPARTMENT								
101-1336-70300	APPOINTED OFFICIAL	133,558.40	137,572.00	137,572.00	110,157.81	0.00	27,414.19	80.07
101-1336-70602	CLERICAL	197,937.02	276,253.00	276,253.00	205,034.98	0.00	71,218.02	74.22
101-1336-70603	FIREMEN	11,241,222.71	12,687,538.00	12,687,538.00	9,579,235.11	0.00	3,108,302.89	75.50
101-1336-70606	FIREFIGHTER CADETS	241,831.07	293,400.00	293,400.00	91,907.93	0.00	201,492.07	31.33
101-1336-70703	CLERICAL CO-OP	0.00	35,000.00	35,000.00	6,261.75	0.00	28,738.25	17.89
101-1336-70902	OVERTIME - CLERICAL	2,328.87	5,000.00	5,000.00	525.00	0.00	4,475.00	10.50
101-1336-70903	OVERTIME - FIRE FIGHTERS	2,029,527.73	1,000,000.00	1,000,000.00	1,451,847.78	0.00	(451,847.78)	145.18
101-1336-70906	OVERTIME - FF CADETS	0.00	5,000.00	5,000.00	0.00	0.00	5,000.00	0.00
101-1336-71000	SHIFT PREMIUM	66,876.93	150,000.00	150,000.00	40,601.11	0.00	109,398.89	27.07
101-1336-71302	EDUCATION ALLOWANCE	23,850.01	23,950.00	23,950.00	19,275.00	0.00	4,675.00	80.48
101-1336-71303	CLEAN/CLOTHING ALLOWANCE	10,491.32	17,450.00	17,450.00	11,097.63	0.00	6,352.37	63.60
101-1336-71304	FOOD ALLOWANCE	121,085.07	129,000.00	129,000.00	60,860.91	0.00	68,139.09	47.18
101-1336-71306	AEMT LICENSE ALLOWANCE	27,249.97	17,500.00	17,500.00	7,833.33	0.00	9,666.67	44.76
101-1336-71500	SOCIAL SECURITY	247,073.13	279,155.00	279,155.00	199,572.39	0.00	79,582.61	71.49
101-1336-71700	HOLIDAY PAY	697,829.78	835,375.00	835,375.00	680,059.26	0.00	155,315.74	81.41
101-1336-71900	EMPLOYEE INSURANCES	2,594,189.87	3,421,764.00	3,421,764.00	2,484,280.91	0.00	937,483.09	72.60
101-1336-71904	RETIREE HEALTH INSURANCE	3,680,568.00	2,949,803.00	2,949,803.00	2,458,170.00	0.00	491,633.00	83.33
101-1336-71905	H.S.A. EXPENSE	206,128.55	255,861.00	255,861.00	192,385.48	0.00	63,475.52	75.19
101-1336-71906	SUPPL LIFE INSURANCE EXP	4,125.77	46,777.00	46,777.00	3,320.66	0.00	43,456.34	7.10
101-1336-72100	LONGEVITY	163,252.80	173,502.00	173,502.00	122,601.83	0.00	50,900.17	70.66
101-1336-72101	BONUS/SICK REDEMPTION	10,368.15	18,473.00	18,473.00	2,955.51	0.00	15,517.49	16.00

REVENUE AND EXPENDITURE REPORT

PERIOD ENDING 04/30/2024

% Fiscal Year Completed: 83.33

GL NUMBER	DESCRIPTION	END BALANCE	2023-24		YTD BALANCE	ENCUMBERED	UNENCUMBERED	% BDGT
		06/30/2023	ORIGINAL	2023-24	04/30/2024			
		NORM (ABNORM)	BUDGET	AMENDED BUDGET	NORM (ABNORM)	YEAR-TO-DATE	BALANCE	USED
Fund 101 - GENERAL FUND								
101-1336-72200	RETIREMENT FUND	5,063,388.00	5,233,072.00	5,233,072.00	4,360,890.00	0.00	872,182.00	83.33
101-1336-72201	DEFINED CONTRIBUTION EXP	41,084.21	55,156.00	55,156.00	37,927.46	0.00	17,228.54	68.76
101-1336-72401	UNIFORMS	94,099.65	110,450.00	119,950.00	92,635.30	10,634.49	16,680.21	86.09
101-1336-72701	EMS MEDICAL SUPPLIES	206,813.70	233,000.00	233,000.00	160,746.32	38,832.39	33,421.29	85.66
101-1336-74000	OPERATING SUPPLIES	407,656.83	410,000.00	430,226.00	377,386.74	169,759.25	(116,919.99)	127.18
101-1336-75100	GAS & OIL	196,784.55	225,000.00	225,000.00	128,691.59	1,407.36	94,901.05	57.82
101-1336-80100	CONTRACTUAL SERVICES	396,411.79	596,021.00	618,686.00	365,575.34	105,224.67	147,885.99	76.10
101-1336-80101	FIRE PREVENTION WEEK	33,691.50	60,200.00	60,200.00	38,368.14	13,864.95	7,966.91	86.77
101-1336-82401	INSTRUCTION	141,226.45	386,100.00	556,600.00	248,889.89	108,121.12	199,588.99	64.14
101-1336-82800	MEDICAL SERVICES	11,849.00	58,500.00	58,500.00	405.34	16,861.00	41,233.66	29.52
101-1336-85300	TELEPHONE & RADIO	84,888.10	86,000.00	106,000.00	58,529.96	7,349.42	40,120.62	62.15
101-1336-92000	PUBLIC UTILITIES	141,845.49	160,000.00	160,000.00	103,380.72	0.00	56,619.28	64.61
101-1336-93000	BUILDING MAINTENANCE	210,904.53	406,000.00	406,000.00	159,476.43	266,484.10	(19,960.53)	104.92
101-1336-93100	HYDRANT INST & REPAIR	30,000.00	30,000.00	30,000.00	25,000.00	0.00	5,000.00	83.33
101-1336-94100	PUBLIC FIRE PROTECTION	60,000.00	60,000.00	60,000.00	50,000.00	0.00	10,000.00	83.33
101-1336-95800	MEMBERSHIPS & DUES	2,751.20	31,070.00	31,070.00	9,270.37	750.00	21,049.63	32.25
101-1336-97400	CAPITAL IMPROVEMENTS	325,705.68	1,914,107.00	6,416,047.00	703,567.57	5,150,538.98	561,940.45	91.24
101-1336-98401	FIRE EQUIPMENT	574,835.37	1,694,000.00	1,889,615.00	1,456,415.62	82,351.97	350,847.41	81.43
101-1336-98469	MI ECONOMIC DEVELOPMENT MEDC	0.00	0.00	400,000.00	0.00	400,000.00	0.00	100.00
Net - Dept 1336 - FIRE DEPARTMENT		(29,723,431.20)	(34,507,049.00)	(39,847,495.00)	(26,105,141.17)	(6,372,179.70)	(7,370,174.13)	
Dept 1371 - BUILDING INSPECTIONS								
101-1371-70500	SUPERVISORY	106,056.58	124,630.00	124,630.00	66,543.57	0.00	58,086.43	53.39
101-1371-70602	CLERICAL	192,729.91	354,924.00	354,924.00	87,482.48	0.00	267,441.52	24.65
101-1371-70609	INSPECTORS	1,249,913.91	1,600,211.00	1,600,211.00	1,147,722.12	0.00	452,488.88	71.72
101-1371-70703	CLERICAL CO-OP	49,623.25	95,000.00	95,000.00	70,074.25	0.00	24,925.75	73.76
101-1371-70705	TEMPORARY - INSPECTION	88,581.60	175,000.00	175,000.00	11,059.05	0.00	163,940.95	6.32
101-1371-70902	OVERTIME - CLERICAL	2,489.25	5,000.00	5,000.00	2,612.16	0.00	2,387.84	52.24
101-1371-70909	OVERTIME - INSPECTORS	75,388.24	70,000.00	70,000.00	68,742.59	0.00	1,257.41	98.20
101-1371-71303	CLEAN/CLOTHING ALLOWANCE	6,600.00	9,450.00	9,450.00	7,554.17	0.00	1,895.83	79.94
101-1371-71500	SOCIAL SECURITY	137,398.41	194,175.00	194,175.00	115,134.92	0.00	79,040.08	59.29
101-1371-71900	EMPLOYEE INSURANCES	394,924.96	679,521.00	679,521.00	373,680.31	0.00	305,840.69	54.99
101-1371-71904	RETIREE HEALTH INSURANCE	251,196.00	251,196.00	251,196.00	209,330.00	0.00	41,866.00	83.33
101-1371-71905	H.S.A. EXPENSE	29,964.28	41,689.00	41,689.00	25,811.60	0.00	15,877.40	61.91
101-1371-71906	SUPPL LIFE INSURANCE EXP	3,392.48	4,000.00	4,000.00	3,553.89	0.00	446.11	88.85
101-1371-72100	LONGEVITY	27,250.58	34,023.00	34,023.00	22,611.52	0.00	11,411.48	66.46
101-1371-72101	BONUS/SICK REDEMPTION	32,311.01	69,589.00	69,589.00	39,466.01	0.00	30,122.99	56.71
101-1371-72200	RETIREMENT FUND	248,872.00	229,116.00	229,116.00	190,930.00	0.00	38,186.00	83.33
101-1371-72201	DEFINED CONTRIBUTION EXP	173,022.40	238,316.00	238,316.00	147,770.49	0.00	90,545.51	62.01
101-1371-72501	FEES & PER DIEM	11,273.32	15,000.00	15,000.00	10,190.69	0.00	4,809.31	67.94
101-1371-72700	OFFICE SUPPLIES	30,868.99	47,000.00	47,000.00	16,292.84	16,388.90	14,318.26	69.54
101-1371-80100	CONTRACTUAL SERVICES	66,542.86	204,000.00	204,000.00	92,271.85	18,002.04	93,726.11	54.06
101-1371-80106	SOFTWARE SERVICES	4,968.43	14,800.00	14,800.00	0.00	700.00	14,100.00	4.73
101-1371-80141	TITLE SEARCH	5,820.00	12,000.00	12,000.00	2,405.00	3,595.00	6,000.00	50.00
101-1371-80142	NUISANCE ABATE-DEMOL EXP	0.00	25,000.00	25,000.00	0.00	0.00	25,000.00	0.00
101-1371-80200	POSTAGE	5,223.27	15,000.00	15,000.00	3,135.35	0.00	11,864.65	20.90
101-1371-85300	TELEPHONE & RADIO	2,597.93	19,775.00	19,775.00	899.68	0.00	18,875.32	4.55
101-1371-86300	VEHICLE MAINTENANCE	18,655.68	37,000.00	37,000.00	10,916.69	643.75	25,439.56	31.24
101-1371-98000	OFFICE EQUIPMENT	58,992.52	17,000.00	17,000.00	0.00	0.00	17,000.00	0.00
101-1371-98100	VEHICLES	199,873.00	134,000.00	141,400.00	127,853.00	0.00	13,547.00	90.42
Net - Dept 1371 - BUILDING INSPECTIONS		(3,474,530.86)	(4,716,415.00)	(4,723,815.00)	(2,854,044.23)	(39,329.69)	(1,830,441.08)	
Dept 1400 - PLANNING								

REVENUE AND EXPENDITURE REPORT

PERIOD ENDING 04/30/2024

% Fiscal Year Completed: 83.33

GL NUMBER	DESCRIPTION	END BALANCE	2023-24		YTD BALANCE	ENCUMBERED	UNENCUMBERED	% BDGT
		06/30/2023	ORIGINAL	2023-24	04/30/2024			
		NORM (ABNORM)	BUDGET	AMENDED BUDGET	NORM (ABNORM)	YEAR-TO-DATE	BALANCE	USED
Fund 101 - GENERAL FUND								
101-1400-70300	APPOINTED OFFICIAL	110,290.77	113,606.00	113,606.00	90,966.43	0.00	22,639.57	80.07
101-1400-70600	PERMANENT EMPLOYEES	236,928.27	447,026.00	447,026.00	235,987.44	0.00	211,038.56	52.79
101-1400-70712	TEMPORARY - PLANNING AIDE	23,760.04	35,360.00	31,360.00	0.00	0.00	31,360.00	0.00
101-1400-70900	OVERTIME	4,370.30	5,000.00	9,000.00	6,460.24	0.00	2,539.76	71.78
101-1400-71303	CLEAN/CLOTHING ALLOWANCE	1,350.00	2,450.00	2,450.00	1,750.00	0.00	700.00	71.43
101-1400-71500	SOCIAL SECURITY	30,297.37	48,463.00	48,463.00	26,894.99	0.00	21,568.01	55.50
101-1400-71900	EMPLOYEE INSURANCES	60,906.28	183,422.00	183,422.00	65,070.88	0.00	118,351.12	35.48
101-1400-71904	RETIREE HEALTH INSURANCE	45,674.00	45,674.00	45,674.00	38,060.00	0.00	7,614.00	83.33
101-1400-71905	H.S.A. EXPENSE	5,102.04	9,512.00	9,512.00	5,153.30	0.00	4,358.70	54.18
101-1400-71906	SUPPL LIFE INSURANCE EXP	2,083.92	2,480.00	2,480.00	1,844.60	0.00	635.40	74.38
101-1400-72100	LONGEVITY	5,221.76	8,810.00	8,810.00	7,168.46	0.00	1,641.54	81.37
101-1400-72101	BONUS/SICK REDEMPTION	12,783.93	21,124.00	21,124.00	8,040.31	0.00	13,083.69	38.06
101-1400-72201	DEFINED CONTRIBUTION EXP	43,594.19	65,934.00	65,934.00	40,198.21	0.00	25,735.79	60.97
101-1400-72500	MEETING ALLOWANCE	12,000.00	19,275.00	19,275.00	8,775.00	0.00	10,500.00	45.53
101-1400-72700	OFFICE SUPPLIES	11,269.42	18,550.00	18,550.00	10,675.03	6,052.02	1,822.95	90.17
101-1400-80100	CONTRACTUAL SERVICES	9,000.00	141,200.00	311,200.00	6,800.00	63,375.00	241,025.00	22.55
101-1400-80200	POSTAGE	4,488.27	8,000.00	8,000.00	3,964.64	0.00	4,035.36	49.56
101-1400-86300	VEHICLE MAINTENANCE	125.03	1,000.00	1,000.00	0.00	0.00	1,000.00	0.00
101-1400-90000	PRINTING & PUBLISHING	7,265.58	16,000.00	16,000.00	1,275.00	1,725.00	13,000.00	18.75
101-1400-95800	MEMBERSHIPS & DUES	18,913.00	20,950.00	20,950.00	19,826.00	0.00	1,124.00	94.63
101-1400-98000	OFFICE EQUIPMENT	11,524.00	0.00	0.00	0.00	0.00	0.00	0.00
Net - Dept 1400 - PLANNING		(656,948.17)	(1,213,836.00)	(1,383,836.00)	(578,910.53)	(71,152.02)	(733,773.45)	
Dept 1401 - COMMUNITY & ECONOMIC DEVE								
101-1401-70600	PERMANENT EMPLOYEES	77,448.73	175,382.00	175,382.00	106,521.03	0.00	68,860.97	60.74
101-1401-70700	TEMPORARY EMPLOYEES	0.00	35,000.00	35,000.00	4,415.00	0.00	30,585.00	12.61
101-1401-71303	CLEAN/CLOTHING ALLOWANCE	350.00	1,050.00	1,050.00	700.00	0.00	350.00	66.67
101-1401-71500	SOCIAL SECURITY	6,419.97	16,707.00	16,707.00	8,926.51	0.00	7,780.49	53.43
101-1401-71900	EMPLOYEE INSURANCES	4,520.49	64,338.00	64,338.00	6,062.47	0.00	58,275.53	9.42
101-1401-71905	H.S.A. EXPENSE	1,722.02	3,669.00	3,669.00	2,302.42	0.00	1,366.58	62.75
101-1401-71906	SUPPL LIFE INSURANCE EXP	57.60	360.00	360.00	56.28	0.00	303.72	15.63
101-1401-72100	LONGEVITY	2,964.64	3,400.00	3,400.00	3,400.00	0.00	0.00	100.00
101-1401-72101	BONUS/SICK REDEMPTION	1,140.26	3,524.00	3,524.00	0.00	0.00	3,524.00	0.00
101-1401-72201	DEFINED CONTRIBUTION EXP	8,610.32	18,337.00	18,337.00	11,512.08	0.00	6,824.92	62.78
101-1401-72700	OFFICE SUPPLIES	0.00	1,000.00	1,000.00	146.22	0.00	853.78	14.62
101-1401-80200	POSTAGE	3.52	2,500.00	2,500.00	45.47	0.00	2,454.53	1.82
101-1401-86300	VEHICLE MAINTENANCE	1,291.61	1,500.00	1,500.00	22.50	0.00	1,477.50	1.50
101-1401-90000	PRINTING & PUBLISHING	641.00	5,000.00	5,000.00	1,731.84	3,239.85	28.31	99.43
101-1401-95800	MEMBERSHIPS & DUES	1,985.00	3,000.00	3,000.00	0.00	0.00	3,000.00	0.00
101-1401-95808	8 MILE BOULEVARD ASSOC DUES	0.00	7,200.00	7,200.00	6,700.00	0.00	500.00	93.06
Net - Dept 1401 - COMMUNITY & ECONOMIC DEVE		(107,155.16)	(341,967.00)	(341,967.00)	(152,541.82)	(3,239.85)	(186,185.33)	
Dept 1410 - ZONING BOARD OF APPEALS								
101-1410-72500	MEETING ALLOWANCE	12,975.00	16,200.00	16,200.00	7,125.00	0.00	9,075.00	43.98
101-1410-72700	OFFICE SUPPLIES	301.60	1,470.00	1,470.00	0.00	0.00	1,470.00	0.00
101-1410-80102	COURT REPORTER	165.00	3,000.00	3,000.00	0.00	0.00	3,000.00	0.00
101-1410-80200	POSTAGE	2,314.43	6,000.00	6,000.00	1,962.56	0.00	4,037.44	32.71
101-1410-90000	PRINTING & PUBLISHING	0.00	840.00	840.00	0.00	0.00	840.00	0.00
Net - Dept 1410 - ZONING BOARD OF APPEALS		(15,756.03)	(27,510.00)	(27,510.00)	(9,087.56)	0.00	(18,422.44)	
Dept 1421 - PUBLIC SERVICES DIRECTOR								

REVENUE AND EXPENDITURE REPORT

PERIOD ENDING 04/30/2024

% Fiscal Year Completed: 83.33

GL NUMBER	DESCRIPTION	END BALANCE	2023-24		YTD BALANCE	ENCUMBERED	UNENCUMBERED	% BDGT
		06/30/2023	ORIGINAL	2023-24	04/30/2024			
		NORM (ABNORM)	BUDGET	AMENDED BUDGET	NORM (ABNORM)	YEAR-TO-DATE	BALANCE	USED
Fund 101 - GENERAL FUND								
101-1421-70300	APPOINTED OFFICIAL	129,791.39	133,693.00	133,693.00	110,572.21	0.00	23,120.79	82.71
101-1421-70600	PERMANENT EMPLOYEES	140,609.88	227,297.00	227,297.00	116,014.59	0.00	111,282.41	51.04
101-1421-70900	OVERTIME	0.00	0.00	5,465.00	5,463.20	0.00	1.80	99.97
101-1421-71303	CLEAN/CLOTHING ALLOWANCE	1,000.00	1,400.00	1,400.00	1,225.00	0.00	175.00	87.50
101-1421-71500	SOCIAL SECURITY	21,608.26	29,316.00	29,316.00	19,619.63	0.00	9,696.37	66.92
101-1421-71900	EMPLOYEE INSURANCES	57,041.23	90,106.00	90,106.00	52,400.92	0.00	37,705.08	58.15
101-1421-71904	RETIREE HEALTH INSURANCE	22,837.00	22,837.00	22,837.00	19,030.00	0.00	3,807.00	83.33
101-1421-71905	H.S.A. EXPENSE	3,966.73	5,796.00	5,796.00	2,864.63	0.00	2,931.37	49.42
101-1421-71906	SUPPL LIFE INSURANCE EXP	780.00	1,068.00	1,068.00	886.51	0.00	181.49	83.01
101-1421-72100	LONGEVITY	7,938.30	7,973.00	7,973.00	7,972.44	0.00	0.56	99.99
101-1421-72101	BONUS/SICK REDEMPTION	5,967.48	12,794.00	12,794.00	9,834.31	0.00	2,959.69	76.87
101-1421-72201	DEFINED CONTRIBUTION EXP	28,530.78	38,317.00	38,317.00	25,732.72	0.00	12,584.28	67.16
101-1421-72700	OFFICE SUPPLIES	3,241.02	6,300.00	6,300.00	1,720.96	2,784.18	1,794.86	71.51
101-1421-80200	POSTAGE	1,103.19	2,000.00	2,000.00	972.88	0.00	1,027.12	48.64
101-1421-85300	TELEPHONE & RADIO	989.32	1,567.00	1,567.00	720.22	0.00	846.78	45.96
101-1421-86300	VEHICLE MAINTENANCE	0.00	600.00	600.00	0.00	0.00	600.00	0.00
101-1421-98000	OFFICE EQUIPMENT	7,952.00	0.00	0.00	0.00	0.00	0.00	0.00
Net - Dept 1421 - PUBLIC SERVICES DIRECTOR		(433,356.58)	(581,064.00)	(586,529.00)	(375,030.22)	(2,784.18)	(208,714.60)	
Dept 1422 - PROPERTY MAINTENANCE								
101-1422-70600	PERMANENT EMPLOYEES	254,237.49	414,457.00	414,457.00	249,863.20	0.00	164,593.80	60.29
101-1422-70609	INSPECTORS	156,097.27	202,587.00	202,587.00	89,426.04	0.00	113,160.96	44.14
101-1422-70700	TEMPORARY EMPLOYEES	35,805.60	35,000.00	35,000.00	31,836.00	0.00	3,164.00	90.96
101-1422-70705	TEMPORARY - INSPECTION	801,605.90	1,265,000.00	1,265,000.00	539,952.00	0.00	725,048.00	42.68
101-1422-70909	OVERTIME - INSPECTORS	25,657.40	250,000.00	250,000.00	18,151.01	0.00	231,848.99	7.26
101-1422-71303	CLEAN/CLOTHING ALLOWANCE	2,604.95	4,200.00	4,200.00	3,150.00	0.00	1,050.00	75.00
101-1422-71500	SOCIAL SECURITY	97,250.54	167,021.00	167,021.00	71,420.35	0.00	95,600.65	42.76
101-1422-71900	EMPLOYEE INSURANCES	183,157.56	399,955.00	399,955.00	145,670.36	0.00	254,284.64	36.42
101-1422-71905	H.S.A. EXPENSE	8,643.06	17,669.00	17,669.00	7,335.04	0.00	10,333.96	41.51
101-1422-71906	SUPPL LIFE INSURANCE EXP	1,092.86	1,578.00	1,578.00	680.77	0.00	897.23	43.14
101-1422-72100	LONGEVITY	957.16	3,624.00	3,624.00	2,401.44	0.00	1,222.56	66.26
101-1422-72101	BONUS/SICK REDEMPTION	5,899.21	8,360.00	8,360.00	8,075.82	0.00	284.18	96.60
101-1422-72201	DEFINED CONTRIBUTION EXP	43,735.64	88,324.00	88,324.00	36,675.09	0.00	51,648.91	41.52
101-1422-72700	OFFICE SUPPLIES	25,851.21	11,000.00	11,000.00	3,341.51	4,479.35	3,179.14	71.10
101-1422-74000	OPERATING SUPPLIES	0.00	65,000.00	65,000.00	11,683.54	3,948.86	49,367.60	24.05
101-1422-80107	WEED MOWING	171,561.00	350,000.00	350,000.00	158,096.00	93,000.00	98,904.00	71.74
101-1422-80108	RODENT CONTROL	354,620.00	375,000.00	375,000.00	256,266.00	98,734.00	20,000.00	94.67
101-1422-80200	POSTAGE	2,376.71	5,000.00	5,000.00	1,592.47	0.00	3,407.53	31.85
101-1422-82216	WEST NILE VIRUS EXPENSE	0.00	10,000.00	10,000.00	0.00	0.00	10,000.00	0.00
101-1422-82217	WILDLIFE NUISANCE CONTROL	0.00	20,000.00	20,000.00	0.00	0.00	20,000.00	0.00
101-1422-85300	TELEPHONE & RADIO	3,576.26	4,450.00	4,450.00	2,750.82	0.00	1,699.18	61.82
101-1422-86300	VEHICLE MAINTENANCE	47,049.39	50,000.00	50,000.00	25,321.75	0.00	24,678.25	50.64
101-1422-90000	PRINTING & PUBLISHING	3,909.00	20,000.00	20,000.00	1,340.00	1,323.00	17,337.00	13.32
101-1422-92000	PUBLIC UTILITIES	0.00	1,500.00	1,500.00	4,268.39	0.00	(2,768.39)	284.56
101-1422-98100	VEHICLES	35,200.00	192,500.00	210,100.00	17,600.00	0.00	192,500.00	8.38
101-1422-98400	EQUIPMENT	1,109.66	26,000.00	26,000.00	25,000.00	0.00	1,000.00	96.15
Net - Dept 1422 - PROPERTY MAINTENANCE		(2,261,997.87)	(3,988,225.00)	(4,005,825.00)	(1,711,897.60)	(201,485.21)	(2,092,442.19)	
Dept 1426 - CIVIL DEFENSE								
101-1426-70605	POLICEMEN	109,604.80	104,401.00	104,401.00	83,595.05	0.00	20,805.95	80.07
101-1426-70905	OVERTIME - POLICEMEN	4,998.67	8,000.00	8,000.00	5,742.41	0.00	2,257.59	71.78
101-1426-71000	SHIFT PREMIUM	0.00	100.00	100.00	48.00	0.00	52.00	48.00
101-1426-71301	GUN ALLOWANCE	950.00	950.00	950.00	0.00	0.00	950.00	0.00

REVENUE AND EXPENDITURE REPORT

PERIOD ENDING 04/30/2024

% Fiscal Year Completed: 83.33

GL NUMBER	DESCRIPTION	END BALANCE	2023-24		YTD BALANCE	ENCUMBERED	UNENCUMBERED	% BDGT
		06/30/2023	ORIGINAL	2023-24	04/30/2024			
		NORM (ABNORM)	BUDGET	AMENDED BUDGET	NORM (ABNORM)	YEAR-TO-DATE	BALANCE	USED
Fund 101 - GENERAL FUND								
101-1426-71302	EDUCATION ALLOWANCE	0.00	600.00	600.00	600.00	0.00	0.00	100.00
101-1426-71303	CLEAN/CLOTHING ALLOWANCE	202.21	600.00	600.00	600.00	0.00	0.00	100.00
101-1426-71500	SOCIAL SECURITY	1,780.19	1,831.00	1,831.00	1,515.25	0.00	315.75	82.76
101-1426-71700	HOLIDAY PAY	6,203.81	6,400.00	6,400.00	2,788.21	0.00	3,611.79	43.57
101-1426-71900	EMPLOYEE INSURANCES	25,054.01	23,910.00	30,910.00	23,599.93	0.00	7,310.07	76.35
101-1426-71904	RETIREE HEALTH INSURANCE	47,503.00	38,013.00	38,013.00	31,680.00	0.00	6,333.00	83.34
101-1426-71906	SUPPL LIFE INSURANCE EXP	0.00	240.00	240.00	0.00	0.00	240.00	0.00
101-1426-72100	LONGEVITY	2,720.00	2,720.00	2,720.00	2,720.00	0.00	0.00	100.00
101-1426-72101	BONUS/SICK REDEMPTION	0.00	2,400.00	2,400.00	0.00	0.00	2,400.00	0.00
101-1426-72200	RETIREMENT FUND	38,359.00	37,648.00	37,648.00	31,370.00	0.00	6,278.00	83.32
101-1426-72401	UNIFORMS	750.00	750.00	750.00	750.00	0.00	0.00	100.00
101-1426-74000	OPERATING SUPPLIES	1,378.26	2,500.00	2,500.00	0.00	474.04	2,025.96	18.96
101-1426-80100	CONTRACTUAL SERVICES	11,775.25	15,000.00	15,000.00	7,265.00	235.00	7,500.00	50.00
101-1426-92000	PUBLIC UTILITIES	1,300.90	1,600.00	1,600.00	1,149.60	0.00	450.40	71.85
Net - Dept 1426 - CIVIL DEFENSE		(252,580.10)	(247,663.00)	(254,663.00)	(193,423.45)	(709.04)	(60,530.51)	
Dept 1430 - ANIMAL CONTROL								
101-1430-70600	PERMANENT EMPLOYEES	157,231.13	197,784.00	195,284.00	145,851.21	0.00	49,432.79	74.69
101-1430-70900	OVERTIME	1,328.27	7,000.00	7,000.00	0.00	0.00	7,000.00	0.00
101-1430-71303	CLEAN/CLOTHING ALLOWANCE	(0.83)	1,050.00	1,140.00	1,140.00	0.00	0.00	100.00
101-1430-71500	SOCIAL SECURITY	12,083.67	16,315.00	16,315.00	11,025.05	0.00	5,289.95	67.58
101-1430-71900	EMPLOYEE INSURANCES	34,215.72	65,752.00	65,752.00	34,913.37	0.00	30,838.63	53.10
101-1430-71904	RETIREE HEALTH INSURANCE	45,672.00	45,672.00	45,672.00	38,060.00	0.00	7,612.00	83.33
101-1430-71905	H.S.A. EXPENSE	2,895.92	4,266.00	4,266.00	2,966.23	0.00	1,299.77	69.53
101-1430-71906	SUPPL LIFE INSURANCE EXP	165.88	240.00	240.00	140.00	0.00	100.00	58.33
101-1430-72100	LONGEVITY	1,507.75	1,314.00	1,314.00	1,313.42	0.00	0.58	99.96
101-1430-72101	BONUS/SICK REDEMPTION	0.00	6,062.00	6,062.00	0.00	0.00	6,062.00	0.00
101-1430-72200	RETIREMENT FUND	62,217.00	57,278.00	57,278.00	47,730.00	0.00	9,548.00	83.33
101-1430-72201	DEFINED CONTRIBUTION EXP	16,120.60	21,322.00	21,322.00	14,830.48	0.00	6,491.52	69.55
101-1430-72401	UNIFORMS	1,140.00	0.00	0.00	0.00	0.00	0.00	0.00
101-1430-74000	OPERATING SUPPLIES	4,169.46	5,500.00	5,500.00	1,449.11	1,780.89	2,270.00	58.73
101-1430-80500	ANIMAL COLLECTION	95,018.09	135,500.00	135,500.00	70,452.05	44,771.45	20,276.50	85.04
101-1430-86300	VEHICLE MAINTENANCE	3,000.00	3,500.00	6,000.00	3,808.38	0.00	2,191.62	63.47
Net - Dept 1430 - ANIMAL CONTROL		(436,764.66)	(568,555.00)	(568,645.00)	(373,679.30)	(46,552.34)	(148,413.36)	
Dept 1441 - STREET MAINTENANCE DIV								
101-1441-71900	EMPLOYEE INSURANCES	0.00	0.00	0.00	98,880.31	0.00	(98,880.31)	100.00
Net - Dept 1441 - STREET MAINTENANCE DIV		0.00	0.00	0.00	(98,880.31)	0.00	98,880.31	
Dept 1442 - D P W GARAGE								
101-1442-70604	MECHANICS	941,940.89	1,171,616.00	1,171,616.00	744,051.18	0.00	427,564.82	63.51
101-1442-70700	TEMPORARY EMPLOYEES	27,426.00	40,000.00	40,000.00	20,375.60	0.00	19,624.40	50.94
101-1442-70900	OVERTIME	249.12	5,500.00	5,500.00	108.68	0.00	5,391.32	1.98
101-1442-70904	OVERTIME - MECHANICS	40,174.92	100,000.00	100,000.00	27,350.95	0.00	72,649.05	27.35
101-1442-71303	CLEAN/CLOTHING ALLOWANCE	4,386.18	5,600.00	5,600.00	4,200.00	0.00	1,400.00	75.00
101-1442-71500	SOCIAL SECURITY	79,274.58	106,086.00	106,086.00	61,978.73	0.00	44,107.27	58.42
101-1442-71900	EMPLOYEE INSURANCES	208,964.55	387,487.00	387,487.00	182,386.12	0.00	205,100.88	47.07
101-1442-71904	RETIREE HEALTH INSURANCE	182,696.00	182,696.00	182,696.00	152,250.00	0.00	30,446.00	83.34
101-1442-71905	H.S.A. EXPENSE	12,082.99	18,173.00	18,173.00	11,115.01	0.00	7,057.99	61.16
101-1442-71906	SUPPL LIFE INSURANCE EXP	991.56	1,180.00	1,180.00	871.84	0.00	308.16	73.88
101-1442-72100	LONGEVITY	27,513.57	38,220.00	38,220.00	17,818.20	0.00	20,401.80	46.62

REVENUE AND EXPENDITURE REPORT

PERIOD ENDING 04/30/2024

% Fiscal Year Completed: 83.33

GL NUMBER	DESCRIPTION	END BALANCE	2023-24		YTD BALANCE	ENCUMBERED	UNENCUMBERED	% BDGT
		06/30/2023	ORIGINAL	2023-24	04/30/2024			
		NORM (ABNORM)	BUDGET	AMENDED BUDGET	NORM (ABNORM)	YEAR-TO-DATE	BALANCE	USED
Fund 101 - GENERAL FUND								
101-1442-72101	BONUS/SICK REDEMPTION	15,944.21	25,621.00	25,621.00	12,931.55	0.00	12,689.45	50.47
101-1442-72200	RETIREMENT FUND	186,654.00	171,837.00	171,837.00	143,200.00	0.00	28,637.00	83.33
101-1442-72201	DEFINED CONTRIBUTION EXP	96,665.64	130,954.00	130,954.00	84,910.55	0.00	46,043.45	64.84
101-1442-74000	OPERATING SUPPLIES	135,670.90	410,750.00	410,750.00	76,164.24	104,739.73	229,846.03	44.04
101-1442-75100	GAS & OIL	166,066.03	200,000.00	200,000.00	116,392.54	54,417.39	29,190.07	85.40
101-1442-80100	CONTRACTUAL SERVICES	249,560.26	1,509,300.00	1,509,300.00	142,028.19	20,107.15	1,347,164.66	10.74
101-1442-81400	TREE MAINTENANCE	919,817.30	1,000,000.00	1,000,000.00	303,955.14	252,255.08	443,789.78	55.62
101-1442-85300	TELEPHONE & RADIO	6,817.47	19,000.00	19,000.00	6,126.23	99.29	12,774.48	32.77
101-1442-86300	VEHICLE MAINTENANCE	997,315.05	1,750,000.00	1,750,000.00	744,861.98	314,773.38	690,364.64	60.55
101-1442-92000	PUBLIC UTILITIES	92,847.16	140,000.00	140,000.00	61,015.39	0.00	78,984.61	43.58
101-1442-93000	BUILDING MAINTENANCE	17,989.36	314,500.00	314,500.00	14,468.75	29,613.70	270,417.55	14.02
101-1442-96202	CONTRIB TO MAJOR STREETS	0.00	76,905.00	76,905.00	0.00	0.00	76,905.00	0.00
101-1442-96203	CONTRIB TO LOCAL STREETS	0.00	106,905.00	106,905.00	0.00	0.00	106,905.00	0.00
101-1442-97400	CAPITAL IMPROVEMENTS	126,911.89	600,000.00	1,307,050.00	4,775.30	4,272.81	1,298,001.89	0.69
101-1442-98103	DPW VEHICLES/EQUIPMENT	2,221,736.12	2,235,000.00	3,111,234.00	1,107,329.24	1,448,735.50	555,169.26	82.16
Net - Dept 1442 - D P W GARAGE		(6,759,695.75)	(10,747,330.00)	(12,330,614.00)	(4,040,665.41)	(2,229,014.03)	(6,060,934.56)	
Dept 1447 - ENGINEERING & INSPECTIONS								
101-1447-70602	CLERICAL	59,896.21	63,165.00	63,165.00	50,394.68	0.00	12,770.32	79.78
101-1447-70608	ENGINEERS & INSPECTORS	312,122.46	401,947.00	401,947.00	311,005.82	0.00	90,941.18	77.37
101-1447-70705	TEMPORARY - INSPECTION	16,200.00	148,000.00	148,000.00	0.00	0.00	148,000.00	0.00
101-1447-70706	TEMPORARY - ENGINEER	0.00	74,000.00	74,000.00	4,160.00	0.00	69,840.00	5.62
101-1447-70902	OVERTIME - CLERICAL	0.00	500.00	500.00	0.00	0.00	500.00	0.00
101-1447-70908	OVERTIME - ENGINEERING	122,153.30	130,000.00	130,000.00	87,435.22	0.00	42,564.78	67.26
101-1447-71303	CLEAN/CLOTHING ALLOWANCE	1,449.49	2,100.00	2,100.00	2,100.00	0.00	0.00	100.00
101-1447-71500	SOCIAL SECURITY	39,563.32	64,683.00	64,683.00	35,481.99	0.00	29,201.01	54.86
101-1447-71900	EMPLOYEE INSURANCES	98,525.39	177,767.00	177,767.00	116,555.46	0.00	61,211.54	65.57
101-1447-71904	RETIREE HEALTH INSURANCE	68,511.00	68,511.00	68,511.00	57,090.00	0.00	11,421.00	83.33
101-1447-71905	H.S.A. EXPENSE	7,428.20	10,442.00	10,442.00	7,274.01	0.00	3,167.99	69.66
101-1447-71906	SUPL LIFE INSURANCE EXP	1,240.92	1,444.00	1,549.00	1,236.38	0.00	312.62	79.82
101-1447-72100	LONGEVITY	9,553.88	11,283.00	11,283.00	6,800.00	0.00	4,483.00	60.27
101-1447-72101	BONUS/SICK REDEMPTION	3,243.76	14,432.00	14,432.00	6,028.80	0.00	8,403.20	41.77
101-1447-72200	RETIREMENT FUND	124,436.00	114,558.00	114,558.00	95,470.00	0.00	19,088.00	83.34
101-1447-72201	DEFINED CONTRIBUTION EXP	57,495.36	73,914.00	73,914.00	51,829.96	0.00	22,084.04	70.12
101-1447-72700	OFFICE SUPPLIES	15,919.70	42,300.00	43,600.00	20,123.53	12,561.75	10,914.72	74.97
101-1447-80100	CONTRACTUAL SERVICES	259,349.10	240,000.00	240,000.00	100,179.54	200.00	139,620.46	41.82
101-1447-80106	SOFTWARE SERVICES	6,193.00	23,500.00	33,500.00	10,702.52	2,700.00	20,097.48	40.01
101-1447-80119	CONT SERV - INSPECTORS	33,755.45	374,000.00	330,895.00	29,784.77	9,167.19	291,943.04	11.77
101-1447-80200	POSTAGE	596.13	800.00	800.00	412.25	0.00	387.75	51.53
101-1447-85300	TELEPHONE & RADIO	579.94	500.00	1,620.00	1,062.45	0.00	557.55	65.58
101-1447-86300	VEHICLE MAINTENANCE	21,371.59	25,000.00	25,000.00	13,010.59	143.00	11,846.41	52.61
101-1447-95800	MEMBERSHIPS & DUES	8,094.90	13,250.00	13,250.00	8,119.90	0.00	5,130.10	61.28
101-1447-96592	TRANSFER TO WATER & SEWER	159,530.00	165,923.00	165,923.00	138,270.00	0.00	27,653.00	83.33
101-1447-98000	OFFICE EQUIPMENT	9,936.80	0.00	0.00	0.00	0.00	0.00	0.00
101-1447-98100	VEHICLES	0.00	46,000.00	145,710.00	96,628.04	0.00	49,081.96	66.32
101-1447-98400	EQUIPMENT	5,058.05	10,000.00	43,000.00	7,442.19	2,025.81	33,532.00	22.02
Net - Dept 1447 - ENGINEERING & INSPECTIONS		(1,442,203.95)	(2,298,019.00)	(2,400,149.00)	(1,258,598.10)	(26,797.75)	(1,114,753.15)	
Dept 1448 - HIGHWAY STREET LIGHTING								
101-1448-92600	STREET LIGHTING	2,967,447.36	3,300,000.00	3,300,000.00	2,455,638.59	5,000.00	839,361.41	74.56
Net - Dept 1448 - HIGHWAY STREET LIGHTING		(2,967,447.36)	(3,300,000.00)	(3,300,000.00)	(2,455,638.59)	(5,000.00)	(839,361.41)	

REVENUE AND EXPENDITURE REPORT

PERIOD ENDING 04/30/2024

% Fiscal Year Completed: 83.33

GL NUMBER	DESCRIPTION	END BALANCE	2023-24		YTD BALANCE	ENCUMBERED	UNENCUMBERED	% BDGT
		06/30/2023	ORIGINAL	2023-24	04/30/2024			
		NORM (ABNORM)	BUDGET	AMENDED BUDGET	NORM (ABNORM)	YEAR-TO-DATE	BALANCE	USED
Fund 101 - GENERAL FUND								
Dept 1610 - COMM-SR HEALTH CARE SVCS								
101-1610-88001	COMMUNITY PROMOTION/OUTREACH F	745.02	2,000.00	2,000.00	637.53	0.00	1,362.47	31.88
Net - Dept 1610 - COMM-SR HEALTH CARE SVCS		(745.02)	(2,000.00)	(2,000.00)	(637.53)	0.00	(1,362.47)	
Dept 1779 - COUNCIL OF COMMISSIONS								
101-1779-72700	OFFICE SUPPLIES	2.64	100.00	100.00	44.80	0.00	55.20	44.80
101-1779-96137	APPRECIATION RECEPTION	2,807.13	3,850.00	3,850.00	0.00	2,271.83	1,578.17	59.01
Net - Dept 1779 - COUNCIL OF COMMISSIONS		(2,809.77)	(3,950.00)	(3,950.00)	(44.80)	(2,271.83)	(1,633.37)	
Dept 1780 - ANIMAL RIGHTS COMMISSION								
101-1780-72700	OFFICE SUPPLIES	0.00	300.00	300.00	0.00	0.00	300.00	0.00
101-1780-74000	OPERATING SUPPLIES	776.16	1,500.00	1,500.00	160.00	0.00	1,340.00	10.67
101-1780-80200	POSTAGE	0.00	50.00	50.00	0.00	0.00	50.00	0.00
101-1780-82403	EDUCATION	0.00	4,000.00	4,000.00	532.60	1,200.00	2,267.40	43.32
101-1780-85300	TELEPHONE & RADIO	0.00	50.00	50.00	0.00	0.00	50.00	0.00
101-1780-96138	VACCINATION FAIR	2,522.00	3,000.00	3,000.00	420.00	2,350.00	230.00	92.33
101-1780-96139	DOG PARK	0.00	2,100.00	2,100.00	0.00	0.00	2,100.00	0.00
101-1780-96145	CHIPPING CLINIC	2,782.00	3,000.00	3,000.00	0.00	0.00	3,000.00	0.00
101-1780-96149	SPAY/NEUTER CLINIC	0.00	4,000.00	4,000.00	0.00	3,800.00	200.00	95.00
101-1780-96150	COMMUNITY OUTREACH	0.00	2,000.00	2,000.00	0.00	0.00	2,000.00	0.00
Net - Dept 1780 - ANIMAL RIGHTS COMMISSION		(6,080.16)	(20,000.00)	(20,000.00)	(1,112.60)	(7,350.00)	(11,537.40)	
Dept 1793 - BEAUTIFICATION								
101-1793-70700	TEMPORARY EMPLOYEES	3,192.00	0.00	0.00	0.00	0.00	0.00	0.00
101-1793-71500	SOCIAL SECURITY	244.19	0.00	0.00	0.00	0.00	0.00	0.00
101-1793-71900	EMPLOYEE INSURANCES	3.12	0.00	0.00	0.00	0.00	0.00	0.00
101-1793-72700	OFFICE SUPPLIES	55.09	500.00	500.00	43.48	350.00	106.52	78.70
101-1793-80100	CONTRACTUAL SERVICES	5,660.00	6,500.00	10,500.00	3,000.00	0.00	7,500.00	28.57
101-1793-80200	POSTAGE	56.79	1,700.00	1,700.00	156.98	0.00	1,543.02	9.23
101-1793-85300	TELEPHONE & RADIO	63.09	200.00	200.00	37.55	0.00	162.45	18.78
101-1793-86100	MILEAGE	395.90	800.00	800.00	394.90	0.00	405.10	49.36
101-1793-92000	PUBLIC UTILITIES	496.69	1,000.00	1,000.00	329.62	0.00	670.38	32.96
101-1793-96102	SCHOOL PROGRAM	1,096.04	1,200.00	1,200.00	0.00	0.00	1,200.00	0.00
101-1793-96103	AWARDS	3,849.51	9,000.00	5,000.00	4,236.14	301.20	462.66	90.75
101-1793-96104	CLEAN-UP CAMPAIGN	0.00	1,500.00	1,500.00	1,204.00	190.42	105.58	92.96
101-1793-96105	INSTALLATION DINNER	606.78	1,000.00	1,000.00	531.50	0.00	468.50	53.15
101-1793-96123	CITY FLOWER PLANTINGS	1,735.00	4,000.00	4,000.00	0.00	0.00	4,000.00	0.00
101-1793-96134	CHRISTMAS DECORATIONS	14,991.00	26,000.00	26,000.00	26,000.00	0.00	0.00	100.00
Net - Dept 1793 - BEAUTIFICATION		(32,445.20)	(53,400.00)	(53,400.00)	(35,934.17)	(841.62)	(16,624.21)	
Dept 1794 - CULTURAL COMMISSION								
101-1794-72700	OFFICE SUPPLIES	0.00	100.00	100.00	0.00	0.00	100.00	0.00
101-1794-80140	CONT SVCS - SOUND SYSTEM	11,500.00	11,500.00	11,500.00	6,650.00	0.00	4,850.00	57.83
101-1794-96110	SUMMER PROGRAM	16,478.00	16,500.00	16,500.00	13,332.00	0.00	3,168.00	80.80
101-1794-96115	WINTER PROGRAM	771.00	1,000.00	1,000.00	0.00	500.00	500.00	50.00
Net - Dept 1794 - CULTURAL COMMISSION		(28,749.00)	(29,100.00)	(29,100.00)	(19,982.00)	(500.00)	(8,618.00)	

REVENUE AND EXPENDITURE REPORT

PERIOD ENDING 04/30/2024

% Fiscal Year Completed: 83.33

GL NUMBER	DESCRIPTION	END BALANCE	2023-24		YTD BALANCE	ENCUMBERED	UNENCUMBERED	% BDGT
		06/30/2023	ORIGINAL	2023-24	04/30/2024			
		NORM (ABNORM)	BUDGET	AMENDED BUDGET	NORM (ABNORM)	YEAR-TO-DATE	BALANCE	USED
Fund 101 - GENERAL FUND								
Dept 1795 - HISTORICAL COMMISSION								
101-1795-72700	OFFICE SUPPLIES	303.91	1,520.00	1,520.00	54.00	646.00	820.00	46.05
101-1795-85300	TELEPHONE & RADIO	63.09	300.00	300.00	37.55	0.00	262.45	12.52
101-1795-88001	COMMUNITY PROMOTION/OUTREACH E	514.35	1,200.00	1,200.00	0.00	0.00	1,200.00	0.00
101-1795-95800	MEMBERSHIPS & DUES	263.00	363.00	363.00	218.00	0.00	145.00	60.06
101-1795-96135	HISTORICAL SITE PLAQUES	0.00	1,800.00	1,800.00	0.00	0.00	1,800.00	0.00
101-1795-96140	MUSEUM EXPENSE	2,490.26	11,180.00	11,180.00	2,450.00	0.00	8,730.00	21.91
101-1795-96148	HALL OF FAME	0.00	2,000.00	2,000.00	0.00	0.00	2,000.00	0.00
Net - Dept 1795 - HISTORICAL COMMISSION		(3,634.61)	(18,363.00)	(18,363.00)	(2,759.55)	(646.00)	(14,957.45)	
Dept 1796 - VILLAGE HISTORICAL COMM								
101-1796-72700	OFFICE SUPPLIES	100.00	600.00	600.00	0.00	0.00	600.00	0.00
101-1796-80100	CONTRACTUAL SERVICES	7,857.69	24,000.00	24,000.00	4,524.68	4,312.50	15,162.82	36.82
101-1796-88001	COMMUNITY PROMOTION/OUTREACH E	0.00	5,000.00	5,000.00	0.00	0.00	5,000.00	0.00
101-1796-92000	PUBLIC UTILITIES	7,903.09	3,300.00	3,300.00	1,874.72	0.00	1,425.28	56.81
101-1796-96135	HISTORICAL SITE PLAQUES	0.00	3,200.00	3,200.00	0.00	0.00	3,200.00	0.00
101-1796-96141	OLD VILLAGE HALL IMPROVEM	0.00	15,000.00	15,000.00	0.00	0.00	15,000.00	0.00
Net - Dept 1796 - VILLAGE HISTORICAL COMM		(15,860.78)	(51,100.00)	(51,100.00)	(6,399.40)	(4,312.50)	(40,388.10)	
Dept 1797 - VETERANS ADVISORY & MEMORIAL COMMISSION								
101-1797-74000	OPERATING SUPPLIES	0.00	1,000.00	1,000.00	0.00	0.00	1,000.00	0.00
101-1797-88001	COMMUNITY PROMOTION/OUTREACH E	0.00	3,000.00	3,000.00	0.00	0.00	3,000.00	0.00
101-1797-97400	CAPITAL IMPROVEMENTS	0.00	25,000.00	25,000.00	0.00	0.00	25,000.00	0.00
Net - Dept 1797 - VETERANS ADVISORY & MEMORIAL COMMI		0.00	(29,000.00)	(29,000.00)	0.00	0.00	(29,000.00)	
TOTAL REVENUES								
		129,423,699.78	151,942,922.00	162,349,119.00	109,152,173.08	0.00	53,196,945.92	67.23
TOTAL EXPENDITURES								
		126,000,012.12	151,942,922.00	162,349,119.00	111,666,590.83	10,978,599.26	39,703,928.91	75.54
NET OF REVENUES & EXPENDITURES								
		3,423,687.66	0.00	0.00	(2,514,417.75)	(10,978,599.26)	13,493,017.01	100.00
Fund 202 - MTF ACT 51 MAJOR OPERATNG								
Dept 0080 - REVENUES								
202-0080-54900	WEIGHT AND GAS TAX	13,081,122.50	13,259,400.00	13,259,400.00	9,120,083.15	0.00	4,139,316.85	68.78
202-0080-66500	INTEREST ON INVESTMENTS	223,931.37	18,000.00	18,000.00	539,696.19	0.00	(521,696.19)	2,998.31
202-0080-67900	MISCELLANEOUS REVENUE	45,038.45	0.00	0.00	0.00	0.00	0.00	0.00
202-0080-67904	WINTER MAINT (DEQUINDRE)	12,500.00	12,500.00	12,500.00	0.00	0.00	12,500.00	0.00
202-0080-69435	TRANSFER FROM FUND 435	101.76	0.00	0.00	0.00	0.00	0.00	0.00
202-0080-69501	TRANSFER FROM GEN FUND	0.00	76,906.00	76,906.00	0.00	0.00	76,906.00	0.00
202-0080-69901	FUND BALANCE APPROPRIATED	0.00	350,312.00	4,325,491.00	0.00	0.00	4,325,491.00	0.00
Net - Dept 0080 - REVENUES		13,362,694.08	13,717,118.00	17,692,297.00	9,659,779.34	0.00	8,032,517.66	
Dept 2451 - CONSTRUCTION								
202-2451-97400	CAPITAL IMPROVEMENTS	3,467,145.02	1,600,000.00	4,970,733.00	836,384.75	0.00	4,134,348.25	16.83
Net - Dept 2451 - CONSTRUCTION		(3,467,145.02)	(1,600,000.00)	(4,970,733.00)	(836,384.75)	0.00	(4,134,348.25)	

REVENUE AND EXPENDITURE REPORT

PERIOD ENDING 04/30/2024

% Fiscal Year Completed: 83.33

GL NUMBER	DESCRIPTION	END BALANCE	2023-24		YTD BALANCE	ENCUMBERED	UNENCUMBERED	% BDGT
		06/30/2023	ORIGINAL	2023-24	04/30/2024			
		NORM (ABNORM)	BUDGET	AMENDED BUDGET	NORM (ABNORM)	YEAR-TO-DATE	BALANCE	USED
Fund 202 - MTF ACT 51 MAJOR OPERATNG								
Dept 2463 - ROUTINE MAINTENANCE								
202-2463-70600	PERMANENT EMPLOYEES	363,212.91	539,900.00	539,900.00	446,079.11	0.00	93,820.89	82.62
202-2463-70700	TEMPORARY EMPLOYEES	1,593.00	33,750.00	33,750.00	0.00	0.00	33,750.00	0.00
202-2463-70900	OVERTIME	2,870.76	55,081.00	55,081.00	3,504.15	0.00	51,576.85	6.36
202-2463-71302	EDUCATION ALLOWANCE	232.68	882.00	882.00	1,500.00	0.00	(618.00)	170.07
202-2463-71303	CLEAN/CLOTHING ALLOWANCE	6,519.96	2,570.00	2,570.00	8,137.50	0.00	(5,567.50)	316.63
202-2463-71308	CERTIFICATION BONUSES	0.00	823.00	823.00	0.00	0.00	823.00	0.00
202-2463-71500	SOCIAL SECURITY	30,865.73	52,171.00	52,171.00	31,587.30	0.00	20,583.70	60.55
202-2463-71900	EMPLOYEE INSURANCES	103,196.50	192,966.00	192,966.00	91,945.82	0.00	101,020.18	47.65
202-2463-71904	RETIREE HEALTH INSURANCE	123,266.00	127,462.00	127,462.00	106,220.00	0.00	21,242.00	83.33
202-2463-71905	H.S.A. EXPENSE	2,474.48	7,403.00	7,403.00	3,785.72	0.00	3,617.28	51.14
202-2463-71906	SUPL LIFE INSURANCE EXP	512.79	459.00	459.00	2,231.24	0.00	(1,772.24)	486.11
202-2463-72100	LONGEVITY	14,208.49	24,970.00	24,970.00	40,295.92	0.00	(15,325.92)	161.38
202-2463-72101	BONUS/SICK REDEMPTION	18,975.78	23,752.00	23,752.00	28,867.11	0.00	(5,115.11)	121.54
202-2463-72200	RETIREMENT FUND	194,437.00	185,092.00	185,092.00	154,240.00	0.00	30,852.00	83.33
202-2463-72201	DEFINED CONTRIBUTION EXP	28,136.31	55,127.00	55,127.00	29,964.34	0.00	25,162.66	54.36
202-2463-77600	MAINTENANCE SUPPLIES	36,282.08	150,000.00	150,000.00	30,917.78	1,250.00	117,832.22	21.45
202-2463-80100	CONTRACTUAL SERVICES	151,789.80	464,500.00	464,500.00	13,602.92	50,935.00	399,962.08	13.89
202-2463-80205	JOINT SEALING	72,448.10	300,000.00	300,000.00	0.00	0.00	300,000.00	0.00
202-2463-80206	CONCRETE/PAVEMENT REPAIRS	293,372.40	600,000.00	1,135,806.00	260,266.25	0.00	875,539.75	22.91
202-2463-80207	BRIDGE REPAIRS	1,019,681.80	0.00	0.00	0.00	0.00	0.00	0.00
202-2463-94500	EQUIPMENT RENTAL	154,211.54	305,000.00	305,000.00	170,758.30	0.00	134,241.70	55.99
202-2463-96901	SUPERVISORY WAGES/FRINGES	38,463.45	114,259.00	114,259.00	0.00	0.00	114,259.00	0.00
Net - Dept 2463 - ROUTINE MAINTENANCE		(2,656,751.56)	(3,236,167.00)	(3,771,973.00)	(1,423,903.46)	(52,185.00)	(2,295,884.54)	
Dept 2474 - TRAFFIC SERVICES								
202-2474-70600	PERMANENT EMPLOYEES	23,967.42	30,067.00	30,067.00	18,726.69	0.00	11,340.31	62.28
202-2474-70900	OVERTIME	0.00	3,068.00	3,068.00	0.00	0.00	3,068.00	0.00
202-2474-71302	EDUCATION ALLOWANCE	16.17	49.00	49.00	0.00	0.00	49.00	0.00
202-2474-71303	CLEAN/CLOTHING ALLOWANCE	0.00	143.00	143.00	0.00	0.00	143.00	0.00
202-2474-71308	CERTIFICATION BONUSES	0.00	46.00	46.00	0.00	0.00	46.00	0.00
202-2474-71500	SOCIAL SECURITY	1,897.13	2,761.00	2,761.00	2,000.71	0.00	760.29	72.46
202-2474-71900	EMPLOYEE INSURANCES	7,197.82	10,746.00	10,746.00	5,192.06	0.00	5,553.94	48.32
202-2474-71904	RETIREE HEALTH INSURANCE	6,986.00	7,098.00	7,098.00	5,920.00	0.00	1,178.00	83.40
202-2474-71905	H.S.A. EXPENSE	188.98	413.00	413.00	286.50	0.00	126.50	69.37
202-2474-71906	SUPL LIFE INSURANCE EXP	25.00	26.00	26.00	0.00	0.00	26.00	0.00
202-2474-72100	LONGEVITY	987.72	1,391.00	1,391.00	0.00	0.00	1,391.00	0.00
202-2474-72101	BONUS/SICK REDEMPTION	0.00	1,323.00	1,323.00	0.00	0.00	1,323.00	0.00
202-2474-72200	RETIREMENT FUND	11,019.00	10,308.00	10,308.00	8,590.00	0.00	1,718.00	83.33
202-2474-72201	DEFINED CONTRIBUTION EXP	944.72	3,070.00	3,070.00	1,432.59	0.00	1,637.41	46.66
202-2474-78601	TRAFFIC & STREET SIGNS	1,771.00	5,000.00	5,000.00	1,668.49	0.00	3,331.51	33.37
202-2474-80120	TRAFFIC SIGNALS	119,038.79	240,000.00	246,047.00	7,873.50	0.00	238,173.50	3.20
202-2474-80121	TRAFFIC SIGNAL UPKEEP	350,882.42	300,000.00	300,000.00	197,622.44	0.00	102,377.56	65.87
202-2474-80123	PAVEMENT MARKING	65,546.18	225,000.00	225,000.00	239,398.47	0.00	(14,398.47)	106.40
202-2474-94500	EQUIPMENT RENTAL	6,650.70	28,000.00	28,000.00	5,021.41	0.00	22,978.59	17.93
202-2474-96901	SUPERVISORY WAGES/FRINGES	2,673.83	6,363.00	6,363.00	0.00	0.00	6,363.00	0.00
Net - Dept 2474 - TRAFFIC SERVICES		(599,792.88)	(874,872.00)	(880,919.00)	(493,732.86)	0.00	(387,186.14)	
Dept 2479 - SNOW & ICE CONTROL								
202-2479-70600	PERMANENT EMPLOYEES	14,846.75	51,423.00	51,423.00	16,058.07	0.00	35,364.93	31.23
202-2479-70900	OVERTIME	42,914.05	5,246.00	5,246.00	17,338.05	0.00	(12,092.05)	330.50
202-2479-71302	EDUCATION ALLOWANCE	24.06	84.00	84.00	0.00	0.00	84.00	0.00
202-2479-71303	CLEAN/CLOTHING ALLOWANCE	0.00	245.00	245.00	0.00	0.00	245.00	0.00

REVENUE AND EXPENDITURE REPORT

PERIOD ENDING 04/30/2024

% Fiscal Year Completed: 83.33

GL NUMBER	DESCRIPTION	END BALANCE	2023-24		YTD BALANCE	ENCUMBERED	UNENCUMBERED	% BDGT
		06/30/2023	ORIGINAL	2023-24	04/30/2024			
		NORM (ABNORM)	BUDGET	AMENDED BUDGET	NORM (ABNORM)	YEAR-TO-DATE	BALANCE	USED
Fund 202 - MTF ACT 51 MAJOR OPERATNG								
202-2479-71308	CERTIFICATION BONUSES	0.00	78.00	78.00	0.00	0.00	78.00	0.00
202-2479-71500	SOCIAL SECURITY	4,915.59	4,722.00	4,722.00	2,779.32	0.00	1,942.68	58.86
202-2479-71900	EMPLOYEE INSURANCES	10,455.03	18,379.00	18,379.00	7,977.00	0.00	10,402.00	43.40
202-2479-71904	RETIREE HEALTH INSURANCE	15,143.00	12,140.00	12,140.00	10,120.00	0.00	2,020.00	83.36
202-2479-71905	H.S.A. EXPENSE	505.11	705.00	705.00	422.68	0.00	282.32	59.95
202-2479-71906	SUPL LIFE INSURANCE EXP	53.03	44.00	44.00	0.00	0.00	44.00	0.00
202-2479-72100	LONGEVITY	1,469.37	2,378.00	2,378.00	0.00	0.00	2,378.00	0.00
202-2479-72101	BONUS/SICK REDEMPTION	0.00	2,262.00	2,262.00	0.00	0.00	2,262.00	0.00
202-2479-72200	RETIREMENT FUND	23,885.00	17,629.00	17,629.00	14,690.00	0.00	2,939.00	83.33
202-2479-72201	DEFINED CONTRIBUTION EXP	4,539.50	5,251.00	5,251.00	2,826.53	0.00	2,424.47	53.83
202-2479-77600	MAINTENANCE SUPPLIES	183,831.01	315,000.00	315,000.00	146,097.84	0.00	168,902.16	46.38
202-2479-80100	CONTRACTUAL SERVICES	0.00	25,000.00	25,000.00	0.00	0.00	25,000.00	0.00
202-2479-94500	EQUIPMENT RENTAL	91,169.30	120,000.00	120,000.00	64,177.57	0.00	55,822.43	53.48
202-2479-94501	SALT DOME RENTAL	2,500.00	2,500.00	2,500.00	2,500.00	0.00	0.00	100.00
202-2479-96901	SUPERVISORY WAGES/FRINGES	3,977.68	10,883.00	10,883.00	0.00	0.00	10,883.00	0.00
Net - Dept 2479 - SNOW & ICE CONTROL		(400,228.48)	(593,969.00)	(593,969.00)	(284,987.06)	0.00	(308,981.94)	
Dept 2483 - ADMIN & ENGINEERING								
202-2483-70500	SUPERVISORY	53,472.43	103,744.00	103,744.00	45,468.60	0.00	58,275.40	43.83
202-2483-70602	CLERICAL	54,789.77	101,684.00	101,684.00	47,777.18	0.00	53,906.82	46.99
202-2483-70700	TEMPORARY EMPLOYEES	0.00	17,500.00	17,500.00	0.00	0.00	17,500.00	0.00
202-2483-70902	OVERTIME - CLERICAL	801.72	5,000.00	5,000.00	2,284.80	0.00	2,715.20	45.70
202-2483-71303	CLEAN/CLOTHING ALLOWANCE	500.00	875.00	875.00	583.34	0.00	291.66	66.67
202-2483-71500	SOCIAL SECURITY	9,078.48	18,828.00	18,828.00	7,740.90	0.00	11,087.10	41.11
202-2483-71900	EMPLOYEE INSURANCES	23,208.23	40,094.00	40,094.00	15,490.46	0.00	24,603.54	38.64
202-2483-71904	RETIREE HEALTH INSURANCE	22,836.00	22,836.00	22,836.00	19,030.00	0.00	3,806.00	83.33
202-2483-71905	H.S.A. EXPENSE	500.23	2,637.00	2,637.00	474.68	0.00	2,162.32	18.00
202-2483-71906	SUPL LIFE INSURANCE EXP	260.15	327.00	327.00	200.00	0.00	127.00	61.16
202-2483-72100	LONGEVITY	4,398.36	7,829.00	7,829.00	3,719.99	0.00	4,109.01	47.52
202-2483-72101	BONUS/SICK REDEMPTION	4,827.39	9,445.00	9,445.00	14,369.58	0.00	(4,924.58)	152.14
202-2483-72200	RETIREMENT FUND	31,109.00	28,639.00	28,639.00	23,870.00	0.00	4,769.00	83.35
202-2483-72201	DEFINED CONTRIBUTION EXP	6,195.98	19,669.00	19,669.00	8,503.20	0.00	11,165.80	43.23
202-2483-95000	ADMINISTRATIVE COSTS	714,800.00	736,200.00	736,200.00	613,500.00	0.00	122,700.00	83.33
202-2483-96592	TRANSFER TO WATER & SEWER	36,822.00	44,209.00	44,209.00	36,840.00	0.00	7,369.00	83.33
202-2483-96901	SUPERVISORY WAGES/FRINGES	(74,388.07)	(131,505.00)	(131,505.00)	0.00	0.00	(131,505.00)	0.00
Net - Dept 2483 - ADMIN & ENGINEERING		(889,211.67)	(1,028,011.00)	(1,028,011.00)	(839,852.73)	0.00	(188,158.27)	
Dept 2484 - TRANSFERS TO								
202-2484-96603	LOCAL STREETS	2,500,000.00	1,000,000.00	1,000,000.00	1,000,000.00	0.00	0.00	100.00
202-2484-96656	TRANS TO MTF 2023 DEBT #356	0.00	1,608,420.00	1,671,013.00	401,637.49	0.00	1,269,375.51	24.04
202-2484-96657	TRANS TO MTF 2022 DEBT #357	922,054.17	923,750.00	923,750.00	279,625.00	0.00	644,125.00	30.27
202-2484-96658	TRANS TO 2021A CAP IMP DEBT #3	322,124.75	311,161.00	311,161.00	311,018.79	0.00	142.21	99.95
202-2484-96659	TRANS TO 2015 CAP IMP DEBT #35	191,643.88	182,750.00	182,750.00	182,748.68	0.00	1.32	100.00
202-2484-96660	TRANS TO MTF 2018 DEBT #360	1,105,017.50	1,101,318.00	1,101,318.00	145,908.75	0.00	955,409.25	13.25
202-2484-96661	TRANS TO MTF 2021 DEBT #361	1,258,700.00	1,256,700.00	1,256,700.00	293,600.00	0.00	963,100.00	23.36
Net - Dept 2484 - TRANSFERS TO		(6,299,540.30)	(6,384,099.00)	(6,446,692.00)	(2,614,538.71)	0.00	(3,832,153.29)	
TOTAL REVENUES		13,362,694.08	13,717,118.00	17,692,297.00	9,659,779.34	0.00	8,032,517.66	54.60
TOTAL EXPENDITURES		14,312,669.91	13,717,118.00	17,692,297.00	6,493,399.57	52,185.00	11,146,712.43	37.00

REVENUE AND EXPENDITURE REPORT

PERIOD ENDING 04/30/2024

% Fiscal Year Completed: 83.33

GL NUMBER	DESCRIPTION	END BALANCE	2023-24		YTD BALANCE	ENCUMBERED	UNENCUMBERED	% BDGT
		06/30/2023	ORIGINAL	2023-24	04/30/2024			
		NORM (ABNORM)	BUDGET	AMENDED BUDGET	NORM (ABNORM)	YEAR-TO-DATE	BALANCE	USED
Fund 202 - MTF ACT 51 MAJOR OPERATNG								
NET OF REVENUES & EXPENDITURES		(949,975.83)	0.00	0.00	3,166,379.77	(52,185.00)	(3,114,194.77)	100.00
Fund 203 - MTF ACT 51 LOCAL OPERATNG								
Dept 0080 - REVENUES								
203-0080-54900	WEIGHT AND GAS TAX	4,359,520.77	4,418,250.00	4,418,250.00	3,043,228.65	0.00	1,375,021.35	68.88
203-0080-66500	INTEREST ON INVESTMENTS	103,602.78	12,000.00	12,000.00	215,727.48	0.00	(203,727.48)	1,797.73
203-0080-67905	P.A. 48 - R.O.W. TELECOM	582,991.08	550,000.00	550,000.00	0.00	0.00	550,000.00	0.00
203-0080-69501	TRANSFER FROM GEN FUND	0.00	86,906.00	86,906.00	0.00	0.00	86,906.00	0.00
203-0080-69901	FUND BALANCE APPROPRIATED	0.00	1,009,002.00	3,269,805.00	0.00	0.00	3,269,805.00	0.00
203-0080-69902	TRFR FROM MAJOR ST FUND	2,500,000.00	1,000,000.00	1,000,000.00	1,000,000.00	0.00	0.00	100.00
Net - Dept 0080 - REVENUES		7,546,114.63	7,076,158.00	9,336,961.00	4,258,956.13	0.00	5,078,004.87	
Dept 3451 - CONSTRUCTION								
203-3451-97400	CAPITAL IMPROVEMENTS	0.00	600,000.00	1,009,057.00	0.00	0.00	1,009,057.00	0.00
Net - Dept 3451 - CONSTRUCTION		0.00	(600,000.00)	(1,009,057.00)	0.00	0.00	(1,009,057.00)	
Dept 3463 - ROUTINE MAINTENANCE								
203-3463-70600	PERMANENT EMPLOYEES	904,710.44	1,090,993.00	1,090,993.00	764,673.10	0.00	326,319.90	70.09
203-3463-70700	TEMPORARY EMPLOYEES	3,165.66	41,250.00	41,250.00	0.00	0.00	41,250.00	0.00
203-3463-70900	OVERTIME	29,622.50	111,306.00	111,306.00	28,749.65	0.00	82,556.35	25.83
203-3463-71302	EDUCATION ALLOWANCE	564.07	1,781.00	1,781.00	0.00	0.00	1,781.00	0.00
203-3463-71303	CLEAN/CLOTHING ALLOWANCE	0.00	5,195.00	5,195.00	0.00	0.00	5,195.00	0.00
203-3463-71308	CERTIFICATION BONUSES	0.00	1,662.00	1,662.00	0.00	0.00	1,662.00	0.00
203-3463-71500	SOCIAL SECURITY	73,174.16	103,325.00	103,325.00	65,610.56	0.00	37,714.44	63.50
203-3463-71900	EMPLOYEE INSURANCES	248,729.28	389,933.00	389,933.00	214,316.71	0.00	175,616.29	54.96
203-3463-71904	RETIREE HEALTH INSURANCE	249,700.00	257,567.00	257,567.00	214,640.00	0.00	42,927.00	83.33
203-3463-71905	H.S.A. EXPENSE	7,836.55	14,958.00	14,958.00	9,639.87	0.00	5,318.13	64.45
203-3463-71906	SUPL LIFE INSURANCE EXP	898.00	927.00	927.00	0.00	0.00	927.00	0.00
203-3463-72100	LONGEVITY	34,444.58	50,459.00	50,459.00	0.00	0.00	50,459.00	0.00
203-3463-72101	BONUS/SICK REDEMPTION	0.00	47,997.00	47,997.00	0.00	0.00	47,997.00	0.00
203-3463-72200	RETIREMENT FUND	393,871.00	374,021.00	374,021.00	311,680.00	0.00	62,341.00	83.33
203-3463-72201	DEFINED CONTRIBUTION EXP	71,280.57	111,397.00	111,397.00	71,095.96	0.00	40,301.04	63.82
203-3463-77600	MAINTENANCE SUPPLIES	43,868.38	175,000.00	175,000.00	38,714.49	0.00	136,285.51	22.12
203-3463-80100	CONTRACTUAL SERVICES	75,917.90	710,000.00	710,000.00	51,121.03	110,915.00	547,963.97	22.82
203-3463-80205	JOINT SEALING	24,149.37	100,000.00	100,000.00	0.00	0.00	100,000.00	0.00
203-3463-80206	CONCRETE/PAVEMENT REPAIRS	2,551,303.48	400,000.00	2,251,746.00	1,675,126.35	0.00	576,619.65	74.39
203-3463-94500	EQUIPMENT RENTAL	819,168.06	850,000.00	850,000.00	791,158.34	0.00	58,841.66	93.08
203-3463-96901	SUPERVISORY WAGES/FRINGES	93,244.06	230,887.00	230,887.00	0.00	0.00	230,887.00	0.00
Net - Dept 3463 - ROUTINE MAINTENANCE		(5,625,648.06)	(5,068,658.00)	(6,920,404.00)	(4,236,526.06)	(110,915.00)	(2,572,962.94)	
Dept 3474 - TRAFFIC SERVICES								
203-3474-70600	PERMANENT EMPLOYEES	72,367.42	87,848.00	87,848.00	53,382.19	0.00	34,465.81	60.77
203-3474-70900	OVERTIME	0.00	8,963.00	8,963.00	49.64	0.00	8,913.36	0.55
203-3474-71302	EDUCATION ALLOWANCE	48.75	143.00	143.00	0.00	0.00	143.00	0.00
203-3474-71303	CLEAN/CLOTHING ALLOWANCE	0.00	418.00	418.00	0.00	0.00	418.00	0.00
203-3474-71308	CERTIFICATION BONUSES	0.00	134.00	134.00	0.00	0.00	134.00	0.00
203-3474-71500	SOCIAL SECURITY	5,748.39	8,066.00	8,066.00	5,779.62	0.00	2,286.38	71.65
203-3474-71900	EMPLOYEE INSURANCES	21,773.63	31,398.00	31,398.00	15,269.73	0.00	16,128.27	48.63
203-3474-71904	RETIREE HEALTH INSURANCE	21,564.00	20,740.00	20,740.00	17,280.00	0.00	3,460.00	83.32
203-3474-71905	H.S.A. EXPENSE	568.90	1,204.00	1,204.00	807.28	0.00	396.72	67.05

REVENUE AND EXPENDITURE REPORT

PERIOD ENDING 04/30/2024

% Fiscal Year Completed: 83.33

GL NUMBER	DESCRIPTION	END BALANCE	2023-24		YTD BALANCE	ENCUMBERED	UNENCUMBERED	% BDGT
		06/30/2023	ORIGINAL	2023-24	04/30/2024			
		NORM (ABNORM)	BUDGET	AMENDED BUDGET	NORM (ABNORM)	YEAR-TO-DATE	BALANCE	USED
Fund 203 - MTF ACT 51 LOCAL OPERATNG								
203-3474-71906	SUPPL LIFE INSURANCE EXP	78.00	75.00	75.00	0.00	0.00	75.00	0.00
203-3474-72100	LONGEVITY	2,976.92	4,063.00	4,063.00	0.00	0.00	4,063.00	0.00
203-3474-72101	BONUS/SICK REDEMPTION	0.00	3,865.00	3,865.00	0.00	0.00	3,865.00	0.00
203-3474-72200	RETIREMENT FUND	34,015.00	30,117.00	30,117.00	25,100.00	0.00	5,017.00	83.34
203-3474-72201	DEFINED CONTRIBUTION EXP	2,829.68	8,970.00	8,970.00	4,036.74	0.00	4,933.26	45.00
203-3474-78601	TRAFFIC & STREET SIGNS	2,302.99	5,000.00	5,000.00	2,355.50	0.00	2,644.50	47.11
203-3474-80121	TRAFFIC SIGNAL UPKEEP	71,867.49	65,000.00	65,000.00	76,787.42	0.00	(11,787.42)	118.13
203-3474-80123	PAVEMENT MARKING	21,848.72	75,000.00	75,000.00	83,587.50	0.00	(8,587.50)	111.45
203-3474-94500	EQUIPMENT RENTAL	8,298.10	28,000.00	28,000.00	7,989.74	0.00	20,010.26	28.53
203-3474-96901	SUPERVISORY WAGES/FRINGES	8,058.73	18,591.00	18,591.00	0.00	0.00	18,591.00	0.00
Net - Dept 3474 - TRAFFIC SERVICES		(274,346.72)	(397,595.00)	(397,595.00)	(292,425.36)	0.00	(105,169.64)	
Dept 3479 - SNOW & ICE CONTROL								
203-3479-70600	PERMANENT EMPLOYEES	15,264.01	37,602.00	37,602.00	13,936.42	0.00	23,665.58	37.06
203-3479-70900	OVERTIME	12,348.43	3,836.00	3,836.00	9,267.83	0.00	(5,431.83)	241.60
203-3479-71302	EDUCATION ALLOWANCE	14.27	61.00	61.00	0.00	0.00	61.00	0.00
203-3479-71303	CLEAN/CLOTHING ALLOWANCE	0.00	179.00	179.00	0.00	0.00	179.00	0.00
203-3479-71308	CERTIFICATION BONUSES	0.00	57.00	57.00	0.00	0.00	57.00	0.00
203-3479-71500	SOCIAL SECURITY	2,262.55	3,453.00	3,453.00	1,927.51	0.00	1,525.49	55.82
203-3479-71900	EMPLOYEE INSURANCES	6,069.92	13,439.00	13,439.00	4,310.91	0.00	9,128.09	32.08
203-3479-71904	RETIREE HEALTH INSURANCE	17,225.00	8,877.00	8,877.00	7,400.00	0.00	1,477.00	83.36
203-3479-71905	H.S.A. EXPENSE	261.39	516.00	516.00	295.63	0.00	220.37	57.29
203-3479-71906	SUPPL LIFE INSURANCE EXP	31.44	32.00	32.00	0.00	0.00	32.00	0.00
203-3479-72100	LONGEVITY	871.19	1,739.00	1,739.00	0.00	0.00	1,739.00	0.00
203-3479-72101	BONUS/SICK REDEMPTION	0.00	1,654.00	1,654.00	0.00	0.00	1,654.00	0.00
203-3479-72200	RETIREMENT FUND	27,171.00	12,891.00	12,891.00	10,740.00	0.00	2,151.00	83.31
203-3479-72201	DEFINED CONTRIBUTION EXP	2,050.71	3,839.00	3,839.00	2,009.97	0.00	1,829.03	52.36
203-3479-77600	MAINTENANCE SUPPLIES	54,446.96	255,000.00	255,000.00	59,037.37	0.00	195,962.63	23.15
203-3479-80100	CONTRACTUAL SERVICES	0.00	20,000.00	20,000.00	0.00	0.00	20,000.00	0.00
203-3479-94500	EQUIPMENT RENTAL	54,734.77	155,000.00	155,000.00	48,896.11	0.00	106,103.89	31.55
203-3479-94501	SALT DOME RENTAL	2,500.00	2,500.00	2,500.00	2,500.00	0.00	0.00	100.00
203-3479-96901	SUPERVISORY WAGES/FRINGES	2,358.39	7,958.00	7,958.00	0.00	0.00	7,958.00	0.00
Net - Dept 3479 - SNOW & ICE CONTROL		(197,610.03)	(528,633.00)	(528,633.00)	(160,321.75)	0.00	(368,311.25)	
Dept 3483 - ADMIN & ENGINEERING								
203-3483-70500	SUPERVISORY	53,472.63	103,743.00	103,743.00	45,468.64	0.00	58,274.36	43.83
203-3483-70602	CLERICAL	54,789.98	101,683.00	101,683.00	47,777.12	0.00	53,905.88	46.99
203-3483-70700	TEMPORARY EMPLOYEES	0.00	17,500.00	17,500.00	0.00	0.00	17,500.00	0.00
203-3483-70902	OVERTIME - CLERICAL	801.72	5,000.00	5,000.00	2,284.80	0.00	2,715.20	45.70
203-3483-71303	CLEAN/CLOTHING ALLOWANCE	500.00	875.00	875.00	583.33	0.00	291.67	66.67
203-3483-71500	SOCIAL SECURITY	9,077.89	18,827.00	18,827.00	9,743.23	0.00	9,083.77	51.75
203-3483-71900	EMPLOYEE INSURANCES	23,208.21	40,093.00	40,093.00	15,490.42	0.00	24,602.58	38.64
203-3483-71904	RETIREE HEALTH INSURANCE	22,836.00	22,836.00	22,836.00	19,030.00	0.00	3,806.00	83.33
203-3483-71905	H.S.A. EXPENSE	500.20	2,636.00	2,636.00	474.49	0.00	2,161.51	18.00
203-3483-71906	SUPPL LIFE INSURANCE EXP	259.69	327.00	327.00	199.50	0.00	127.50	61.01
203-3483-72100	LONGEVITY	4,398.36	7,828.00	7,828.00	3,719.98	0.00	4,108.02	47.52
203-3483-72101	BONUS/SICK REDEMPTION	4,827.38	9,445.00	9,445.00	14,369.57	0.00	(4,924.57)	152.14
203-3483-72200	RETIREMENT FUND	31,109.00	28,639.00	28,639.00	23,870.00	0.00	4,769.00	83.35
203-3483-72201	DEFINED CONTRIBUTION EXP	6,195.71	19,668.00	19,668.00	8,502.80	0.00	11,165.20	43.23
203-3483-95000	ADMINISTRATIVE COSTS	261,541.37	315,400.00	315,400.00	262,840.00	0.00	52,560.00	83.34
203-3483-96592	TRANSFER TO WATER & SEWER	36,822.00	44,208.00	44,208.00	36,840.00	0.00	7,368.00	83.33
203-3483-96901	SUPERVISORY WAGES/FRINGES	(74,388.07)	(257,436.00)	(257,436.00)	0.00	0.00	(257,436.00)	0.00
Net - Dept 3483 - ADMIN & ENGINEERING		(435,952.07)	(481,272.00)	(481,272.00)	(491,193.88)	0.00	9,921.88	

REVENUE AND EXPENDITURE REPORT

PERIOD ENDING 04/30/2024

% Fiscal Year Completed: 83.33

GL NUMBER	DESCRIPTION	END BALANCE	2023-24		YTD BALANCE	ENCUMBERED	UNENCUMBERED	% BDGT
		06/30/2023	ORIGINAL	2023-24	04/30/2024			
		NORM (ABNORM)	BUDGET	AMENDED BUDGET	NORM (ABNORM)	YEAR-TO-DATE	BALANCE	USED
Fund 203 - MTF ACT 51 LOCAL OPERATNG								
TOTAL REVENUES		7,546,114.63	7,076,158.00	9,336,961.00	4,258,956.13	0.00	5,078,004.87	45.61
TOTAL EXPENDITURES		6,533,556.88	7,076,158.00	9,336,961.00	5,180,467.05	110,915.00	4,045,578.95	56.67
NET OF REVENUES & EXPENDITURES		1,012,557.75	0.00	0.00	(921,510.92)	(110,915.00)	1,032,425.92	100.00
Fund 204 - 2011 LOCAL STREET R&M								
Dept 0080 - REVENUES								
204-0080-40300	TAX COLLECTIONS	1,078.46	0.00	0.00	1,098.72	0.00	(1,098.72)	100.00
204-0080-40310	PROPERTY TAXES: ROAD MILL	7,712,526.85	8,132,625.00	8,132,625.00	6,821,739.96	0.00	1,310,885.04	83.88
204-0080-43710	IF TAX: ROAD MILLAGE	50,739.22	103,504.00	103,504.00	86,250.00	0.00	17,254.00	83.33
204-0080-57300	LOCAL COMM STABILIZ SHARE	1,007,033.44	320,000.00	320,000.00	433,586.29	0.00	(113,586.29)	135.50
204-0080-66500	INTEREST ON INVESTMENTS	368,542.98	15,000.00	15,000.00	470,225.34	0.00	(455,225.34)	3,134.84
204-0080-69901	FUND BALANCE APPROPRIATED	0.00	0.00	7,072,951.00	0.00	0.00	7,072,951.00	0.00
Net - Dept 0080 - REVENUES		9,139,920.95	8,571,129.00	15,644,080.00	7,812,900.31	0.00	7,831,179.69	
Dept 9204 - 2011 LOCAL ST REPAIR EXP								
204-9204-95000	ADMINISTRATIVE COSTS	288,600.00	297,200.00	297,200.00	247,670.00	0.00	49,530.00	83.33
204-9204-97400	CAPITAL IMPROVEMENTS	9,275,342.73	7,472,410.00	14,545,361.00	2,773,067.30	0.00	11,772,293.70	19.06
Net - Dept 9204 - 2011 LOCAL ST REPAIR EXP		(9,563,942.73)	(7,769,610.00)	(14,842,561.00)	(3,020,737.30)	0.00	(11,821,823.70)	
TOTAL REVENUES		9,139,920.95	8,571,129.00	15,644,080.00	7,812,900.31	0.00	7,831,179.69	49.94
TOTAL EXPENDITURES		9,563,942.73	7,769,610.00	14,842,561.00	3,020,737.30	0.00	11,821,823.70	20.35
NET OF REVENUES & EXPENDITURES		(424,021.78)	801,519.00	801,519.00	4,792,163.01	0.00	(3,990,644.01)	597.89
Fund 208 - RECREATION SPEC REVENUE								
Dept 0080 - REVENUES								
208-0080-40300	TAX COLLECTIONS	942.20	0.00	0.00	659.50	0.00	(659.50)	100.00
208-0080-40308	PROPERTY TAX : RECREATION	3,555,664.39	3,754,675.00	3,754,675.00	3,147,634.71	0.00	607,040.29	83.83
208-0080-43708	IF TAX : RECREATION	23,425.20	47,783.00	47,783.00	39,820.00	0.00	7,963.00	83.34
208-0080-52800	OTHER FEDERAL GRANTS COVID19/A	0.00	1,000,000.00	2,200,000.00	0.00	0.00	2,200,000.00	0.00
208-0080-56605	MDOT - RECREATION	74,285.00	74,285.00	74,285.00	70,736.50	0.00	3,548.50	95.22
208-0080-56607	SMART-COMMUNITY CR. GRANT	191,612.00	147,760.00	147,760.00	54,924.00	0.00	92,836.00	37.17
208-0080-56608	COMMUNITY ENHANCEMENT GRANT	0.00	0.00	1,500,000.00	0.00	0.00	1,500,000.00	0.00
208-0080-57300	LOCAL COMM STABILIZ SHARE	464,940.77	375,000.00	375,000.00	200,178.37	0.00	174,821.63	53.38
208-0080-58105	PLACEMAKING GRANT - MACOMB COU	0.00	0.00	20,000.00	20,000.00	0.00	0.00	100.00
208-0080-65101	RECREATION FEES	169,554.35	175,000.00	175,000.00	157,154.82	0.00	17,845.18	89.80
208-0080-65102	DOWNTOWN SKATE RINK FEES	695.00	15,000.00	15,000.00	3,530.00	0.00	11,470.00	23.53
208-0080-65103	COMMUNITY CENTER FEES	514,771.48	925,000.00	925,000.00	570,513.98	0.00	354,486.02	61.68
208-0080-65104	BINGO FEES	0.00	350.00	350.00	0.00	0.00	350.00	0.00
208-0080-65106	SPONSORED EVENTS REVENUE	44,248.60	40,000.00	40,000.00	34,087.79	0.00	5,912.21	85.22
208-0080-65108	SENIOR TRANSPORTATION	0.00	20,000.00	20,000.00	0.00	0.00	20,000.00	0.00
208-0080-65110	SPECIAL EVENTS REVENUE	1,919.00	70,000.00	70,000.00	1,485.00	0.00	68,515.00	2.12
208-0080-66500	INTEREST ON INVESTMENTS	99,840.47	43,000.00	43,000.00	99,523.38	0.00	(56,523.38)	231.45
208-0080-66801	LEASE PROCEEDS	0.00	55,000.00	0.00	0.00	0.00	0.00	0.00
208-0080-67300	SALE OF EQUIPMENT	8,800.00	0.00	0.00	7,600.00	0.00	(7,600.00)	100.00
208-0080-67900	MISCELLANEOUS REVENUE	1,059.57	7,500.00	7,500.00	1.50	0.00	7,498.50	0.02
208-0080-67913	TELECOM LEASES	68,136.08	0.00	55,000.00	68,136.08	0.00	(13,136.08)	123.88
208-0080-69901	FUND BALANCE APPROPRIATED	0.00	404,130.00	1,302,156.00	0.00	0.00	1,302,156.00	0.00

REVENUE AND EXPENDITURE REPORT

PERIOD ENDING 04/30/2024

% Fiscal Year Completed: 83.33

GL NUMBER	DESCRIPTION	END BALANCE	2023-24		YTD BALANCE	ENCUMBERED	UNENCUMBERED	% BDGT
		06/30/2023	ORIGINAL	2023-24	04/30/2024			
		NORM (ABNORM)	BUDGET	AMENDED BUDGET	NORM (ABNORM)	YEAR-TO-DATE	BALANCE	USED
Fund 208 - RECREATION SPEC REVENUE								
Net - Dept 0080 - REVENUES		5,219,894.11	7,154,483.00	10,772,509.00	4,475,985.63	0.00	6,296,523.37	
Dept 9208 - RECREATION EXPENDITURES								
208-9208-70300	APPOINTED OFFICIAL	118,121.81	121,672.00	121,672.00	102,346.76	0.00	19,325.24	84.12
208-9208-70610	MAINTENANCE	112,974.70	219,720.00	219,720.00	123,298.69	0.00	96,421.31	56.12
208-9208-70612	RECREATION SUPERVISION	353,819.38	391,768.00	391,768.00	298,232.31	0.00	93,535.69	76.12
208-9208-70710	TEMPORARY - MAINTENANCE	0.00	85,000.00	85,000.00	0.00	0.00	85,000.00	0.00
208-9208-70713	TEMPORARY - RECREATION	756,225.23	930,000.00	930,000.00	787,617.24	0.00	142,382.76	84.69
208-9208-70910	OVERTIME - MAINTENANCE	7,139.26	20,000.00	20,000.00	5,933.47	0.00	14,066.53	29.67
208-9208-70912	OVERTIME - REC SUPV	0.00	5,000.00	5,000.00	873.84	0.00	4,126.16	17.48
208-9208-71302	EDUCATION ALLOWANCE	2,500.00	4,500.00	4,500.00	2,500.00	0.00	2,000.00	55.56
208-9208-71303	CLEAN/CLOTHING ALLOWANCE	2,400.00	3,850.00	3,850.00	3,412.50	0.00	437.50	88.64
208-9208-71500	SOCIAL SECURITY	97,668.92	139,432.00	139,432.00	97,492.54	0.00	41,939.46	69.92
208-9208-71900	EMPLOYEE INSURANCES	158,121.13	373,659.00	373,659.00	181,668.25	0.00	191,990.75	48.62
208-9208-71904	RETIREE HEALTH INSURANCE	251,196.00	251,196.00	251,196.00	209,330.00	0.00	41,866.00	83.33
208-9208-71905	H.S.A. EXPENSE	8,758.05	12,150.00	12,150.00	8,291.01	0.00	3,858.99	68.24
208-9208-71906	SUPPL LIFE INSURANCE EXP	936.00	1,284.00	1,284.00	806.00	0.00	478.00	62.77
208-9208-72100	LONGEVITY	11,685.70	13,419.00	13,419.00	12,900.23	0.00	518.77	96.13
208-9208-72101	BONUS/SICK REDEMPTION	20,004.64	27,584.00	27,584.00	27,604.12	0.00	(20.12)	100.07
208-9208-72200	RETIREMENT FUND	186,654.00	171,837.00	171,837.00	143,200.00	0.00	28,637.00	83.33
208-9208-72201	DEFINED CONTRIBUTION EXP	72,665.72	92,202.00	92,202.00	66,075.19	0.00	26,126.81	71.66
208-9208-72700	OFFICE SUPPLIES	3,672.56	8,000.00	8,000.00	3,381.64	994.55	3,623.81	54.70
208-9208-72703	BINGO OPERATING SUPPLIES	0.00	200.00	200.00	0.00	0.00	200.00	0.00
208-9208-74000	OPERATING SUPPLIES	10,064.62	10,000.00	10,000.00	2,511.00	0.56	7,488.44	25.12
208-9208-76000	PLAYGROUND & ATH SUPPLIES	49,667.14	60,000.00	60,000.00	24,845.94	15,847.96	19,306.10	67.82
208-9208-77600	MAINTENANCE SUPPLIES	94,525.24	125,000.00	125,000.00	64,883.48	33,535.96	26,580.56	78.74
208-9208-80100	CONTRACTUAL SERVICES	746,501.02	900,000.00	900,000.00	522,676.13	294,281.91	83,041.96	90.77
208-9208-80116	HORTICULTURE CONSULTANT	537.50	55,000.00	55,000.00	187.50	937.50	53,875.00	2.05
208-9208-80200	POSTAGE	291.19	10,000.00	10,000.00	7,936.95	0.00	2,063.05	79.37
208-9208-80301	UNEMPLOYMENT COSTS	4,656.60	0.00	0.00	0.00	0.00	0.00	0.00
208-9208-81400	TREE MAINTENANCE	18,190.00	25,000.00	25,000.00	0.00	15,000.00	10,000.00	60.00
208-9208-85300	TELEPHONE & RADIO	26,930.05	37,350.00	37,350.00	20,185.71	370.61	16,793.68	55.04
208-9208-86300	VEHICLE MAINTENANCE	39,037.24	40,000.00	40,000.00	25,377.29	0.00	14,622.71	63.44
208-9208-88011	MARKETING/PROMOTIONS - PROGRAM	22,340.74	40,000.00	40,000.00	18,332.43	3,389.57	18,278.00	54.31
208-9208-91000	INSURANCE & BONDS	162,300.00	168,700.00	168,700.00	140,590.00	0.00	28,110.00	83.34
208-9208-92000	PUBLIC UTILITIES	480,064.03	500,000.00	500,000.00	397,237.92	0.00	102,762.08	79.45
208-9208-93000	BUILDING MAINTENANCE	91,166.46	115,000.00	115,000.00	31,128.79	4,731.21	79,140.00	31.18
208-9208-94400	RENTAL & JANITORIAL SERV	1,569.07	5,000.00	5,000.00	1,036.00	464.00	3,500.00	30.00
208-9208-95000	ADMINISTRATIVE COSTS	139,600.00	143,700.00	143,700.00	119,750.00	0.00	23,950.00	83.33
208-9208-96126	SPECIAL EVENTS EXPENSES	74,533.60	70,000.00	70,000.00	27,924.72	27,209.80	14,865.48	78.76
208-9208-96127	SPONSORED EVENTS EXPENSE	24,641.80	40,000.00	40,000.00	19,706.00	11,644.00	8,650.00	78.38
208-9208-96146	DOWNTOWN ICE RINK EXPENSE	10,796.41	15,000.00	15,000.00	10,462.33	3,509.79	1,027.88	93.15
208-9208-96470	TRANS TO FUND 386 BOND PMT	245,713.01	250,339.00	250,339.00	250,336.82	0.00	2.18	100.00
208-9208-97400	CAPITAL IMPROVEMENTS	1,140,570.73	296,500.00	1,188,502.00	137,594.65	60,736.36	990,170.99	16.69
208-9208-98100	VEHICLES	66,856.00	60,000.00	66,024.00	66,024.00	0.00	0.00	100.00
208-9208-98411	EQUIPMENT - RECREATION	49,544.93	70,000.00	70,000.00	38,504.79	0.00	31,495.21	55.01
208-9208-98462	COMMUNITY ENHANCEMENT GRANT	0.00	0.00	1,500,000.00	0.00	0.00	1,500,000.00	0.00
208-9208-98500	ARPA EXPENDITURES	0.00	1,000,000.00	2,200,000.00	0.00	816,602.66	1,383,397.34	37.12
208-9208-98506	PLACEMAKING GT - WEIGAND SPLAS	0.00	0.00	20,000.00	0.00	0.00	20,000.00	0.00
Net - Dept 9208 - RECREATION EXPENDITURES		(5,664,640.48)	(6,909,062.00)	(10,527,088.00)	(4,002,196.24)	(1,289,256.44)	(5,235,635.32)	

Dept 9210 - TRANSPORT EXPENDITURES

208-9210-70713	TEMPORARY - RECREATION	121,527.40	140,000.00	140,000.00	111,119.49	0.00	28,880.51	79.37
----------------	------------------------	------------	------------	------------	------------	------	-----------	-------

REVENUE AND EXPENDITURE REPORT

PERIOD ENDING 04/30/2024

% Fiscal Year Completed: 83.33

GL NUMBER	DESCRIPTION	END BALANCE	2023-24		YTD BALANCE	ENCUMBERED	UNENCUMBERED	% BDGT
		06/30/2023	ORIGINAL	2023-24	04/30/2024			
		NORM (ABNORM)	BUDGET	AMENDED BUDGET	NORM (ABNORM)	YEAR-TO-DATE	BALANCE	USED
Fund 208 - RECREATION SPEC REVENUE								
208-9210-71500	SOCIAL SECURITY	9,296.90	10,710.00	10,710.00	8,500.56	0.00	2,209.44	79.37
208-9210-71900	EMPLOYEE INSURANCES	1,957.87	3,311.00	3,311.00	2,668.09	0.00	642.91	80.58
208-9210-72700	OFFICE SUPPLIES	579.00	2,000.00	2,000.00	0.00	0.00	2,000.00	0.00
208-9210-74000	OPERATING SUPPLIES	0.00	2,000.00	2,000.00	0.00	0.00	2,000.00	0.00
208-9210-80100	CONTRACTUAL SERVICES	5,049.50	10,000.00	10,000.00	2,499.65	6,796.00	704.35	92.96
208-9210-80200	POSTAGE	0.00	100.00	100.00	0.00	0.00	100.00	0.00
208-9210-85300	TELEPHONE & RADIO	593.36	1,000.00	1,000.00	510.37	0.00	489.63	51.04
208-9210-86300	VEHICLE MAINTENANCE	20,622.01	20,000.00	20,000.00	18,213.74	469.38	1,316.88	93.42
208-9210-91000	INSURANCE & BONDS	19,600.00	20,300.00	20,300.00	16,920.00	0.00	3,380.00	83.35
208-9210-92000	PUBLIC UTILITIES	14,680.98	18,000.00	18,000.00	7,353.30	0.00	10,646.70	40.85
208-9210-93000	BUILDING MAINTENANCE	11,970.22	15,000.00	15,000.00	2,532.50	1,790.00	10,677.50	28.82
208-9210-94401	BUS RENTAL	0.00	3,000.00	3,000.00	0.00	0.00	3,000.00	0.00
Net - Dept 9210 - TRANSPORT EXPENDITURES		(205,877.24)	(245,421.00)	(245,421.00)	(170,317.70)	(9,055.38)	(66,047.92)	
TOTAL REVENUES		5,219,894.11	7,154,483.00	10,772,509.00	4,475,985.63	0.00	6,296,523.37	41.55
TOTAL EXPENDITURES		5,870,517.72	7,154,483.00	10,772,509.00	4,172,513.94	1,298,311.82	5,301,683.24	50.79
NET OF REVENUES & EXPENDITURES		(650,623.61)	0.00	0.00	303,471.69	(1,298,311.82)	994,840.13	100.00
Fund 226 - SANITATION SPECIAL REV								
Dept 0080 - REVENUES								
226-0080-40300	TAX COLLECTIONS	2,286.89	0.00	0.00	1,753.46	0.00	(1,753.46)	100.00
226-0080-40304	PROPERTY TAX: SANITATION	10,669,604.32	11,267,679.00	11,267,679.00	9,444,846.28	0.00	1,822,832.72	83.82
226-0080-43704	IF TAX: SANITATION	70,298.83	143,411.00	143,411.00	119,510.00	0.00	23,901.00	83.33
226-0080-57300	LOCAL COMM STABILIZ SHARE	1,395,218.16	440,000.00	440,000.00	600,729.92	0.00	(160,729.92)	136.53
226-0080-66500	INTEREST ON INVESTMENTS	214,060.27	80,000.00	80,000.00	312,468.21	0.00	(232,468.21)	390.59
226-0080-66800	TRANS STATION ROYALTIES	176,965.36	145,000.00	145,000.00	75,372.17	0.00	69,627.83	51.98
226-0080-66801	LEASE PROCEEDS	52,310.60	52,305.00	52,305.00	26,607.36	0.00	25,697.64	50.87
226-0080-67300	SALE OF EQUIPMENT	0.00	0.00	0.00	69,400.00	0.00	(69,400.00)	100.00
226-0080-67901	MISCELLANEOUS - REIMBURS	172,508.82	80,000.00	80,000.00	55,180.26	0.00	24,819.74	68.98
226-0080-67910	SANITATION RECYCLING REV	38,347.89	35,000.00	35,000.00	36,539.68	0.00	(1,539.68)	104.40
226-0080-69901	FUND BALANCE APPROPRIATED	0.00	1,208,436.00	1,675,236.00	0.00	0.00	1,675,236.00	0.00
Net - Dept 0080 - REVENUES		12,791,601.14	13,451,831.00	13,918,631.00	10,742,407.34	0.00	3,176,223.66	
Dept 9226 - SANITATION EXPENDITURES								
226-9226-70501	SUPERINTENDENT	182,794.01	287,294.00	287,294.00	128,639.23	0.00	158,654.77	44.78
226-9226-70602	CLERICAL	82,234.03	145,407.00	145,407.00	80,286.25	0.00	65,120.75	55.21
226-9226-70611	RUBBISH WAGES	1,537,385.86	1,994,006.00	1,994,006.00	1,201,958.21	0.00	792,047.79	60.28
226-9226-70703	CLERICAL CO-OP	9,208.80	0.00	0.00	0.00	0.00	0.00	0.00
226-9226-70711	TEMPORARY - RUBBISH COLL	81,771.51	220,000.00	220,000.00	107,203.41	0.00	112,796.59	48.73
226-9226-70902	OVERTIME - CLERICAL	11,244.41	13,000.00	13,000.00	11,198.82	0.00	1,801.18	86.14
226-9226-70911	OVERTIME - RUBBISH COLL	569,403.24	500,000.00	500,000.00	404,149.56	0.00	95,850.44	80.83
226-9226-71302	EDUCATION ALLOWANCE	1,333.33	2,000.00	2,000.00	1,166.67	0.00	833.33	58.33
226-9226-71303	CLEAN/CLOTHING ALLOWANCE	8,677.07	13,300.00	13,300.00	10,266.67	0.00	3,033.33	77.19
226-9226-71500	SOCIAL SECURITY	192,216.54	248,390.00	248,390.00	150,825.87	0.00	97,564.13	60.72
226-9226-71900	EMPLOYEE INSURANCES	522,838.62	1,095,523.00	1,095,523.00	533,755.40	0.00	561,767.60	48.72
226-9226-71904	RETIREE HEALTH INSURANCE	502,392.00	502,392.00	502,392.00	418,660.00	0.00	83,732.00	83.33
226-9226-71905	H.S.A. EXPENSE	31,901.53	54,288.00	54,288.00	28,580.95	0.00	25,707.05	52.65
226-9226-71906	SUPPL LIFE INSURANCE EXP	2,133.06	4,608.00	4,608.00	1,873.34	0.00	2,734.66	40.65
226-9226-72100	LONGEVITY	39,001.04	43,031.00	43,031.00	19,370.80	0.00	23,660.20	45.02
226-9226-72101	BONUS/SICK REDEMPTION	17,630.86	28,274.00	28,274.00	28,926.16	0.00	(652.16)	102.31

REVENUE AND EXPENDITURE REPORT

PERIOD ENDING 04/30/2024

% Fiscal Year Completed: 83.33

GL NUMBER	DESCRIPTION	END BALANCE	2023-24		YTD BALANCE	ENCUMBERED	UNENCUMBERED	% BDGT
		06/30/2023	ORIGINAL	2023-24	04/30/2024			
		NORM (ABNORM)	BUDGET	AMENDED BUDGET	NORM (ABNORM)	YEAR-TO-DATE	BALANCE	USED
Fund 226 - SANITATION SPECIAL REV								
226-9226-72200	RETIREMENT FUND	622,180.00	572,780.00	572,780.00	477,320.00	0.00	95,460.00	83.33
226-9226-72201	DEFINED CONTRIBUTION EXP	200,487.95	307,214.00	307,214.00	168,761.52	0.00	138,452.48	54.93
226-9226-72700	OFFICE SUPPLIES	14,082.28	15,000.00	15,000.00	3,680.11	3,802.93	7,516.96	49.89
226-9226-74000	OPERATING SUPPLIES	0.00	0.00	65,000.00	4,734.31	13,479.19	46,786.50	28.02
226-9226-75100	GAS & OIL	481,676.50	550,000.00	550,000.00	291,646.64	185,857.47	72,495.89	86.82
226-9226-80100	CONTRACTUAL SERVICES	15,934.04	15,000.00	40,000.00	6,243.65	1,090.49	32,665.86	18.34
226-9226-80109	HAZARDOUS WASTE COLLECTIO	18,660.10	47,000.00	47,000.00	34,007.19	0.00	12,992.81	72.36
226-9226-80112	CONT SERV - RUBBISH HAUL	1,846,371.41	2,500,000.00	2,500,000.00	1,389,752.31	0.00	1,110,247.69	55.59
226-9226-80113	SMDA - CLOSURE COSTS	9,400.00	20,000.00	20,000.00	16,450.00	0.00	3,550.00	82.25
226-9226-80115	CONT SVC - RECYCLE/COMPST	501,138.22	800,000.00	800,000.00	459,616.21	0.00	340,383.79	57.45
226-9226-80200	POSTAGE	0.00	2,500.00	2,500.00	127.48	0.00	2,372.52	5.10
226-9226-80213	SMDA LEGAL/ENG COSTS	37,600.00	50,000.00	65,800.00	65,800.00	0.00	0.00	100.00
226-9226-80301	UNEMPLOYMENT COSTS	2,191.34	500.00	500.00	500.00	0.00	0.00	100.00
226-9226-85300	TELEPHONE & RADIO	6,753.93	11,875.00	11,875.00	5,906.88	126.74	5,841.38	50.81
226-9226-86300	VEHICLE MAINTENANCE	820,058.50	897,000.00	897,000.00	691,350.00	0.00	205,650.00	77.07
226-9226-90000	PRINTING & PUBLISHING	0.00	2,000.00	2,000.00	0.00	1,000.00	1,000.00	50.00
226-9226-92000	PUBLIC UTILITIES	23,328.82	40,000.00	40,000.00	22,796.07	0.00	17,203.93	56.99
226-9226-93000	BUILDING MAINTENANCE	8,634.42	25,000.00	25,000.00	17,798.72	5,351.38	1,849.90	92.60
226-9226-97400	CAPITAL IMPROVEMENTS	99,567.17	76,000.00	76,000.00	7,500.00	16,344.00	52,156.00	31.37
226-9226-98100	VEHICLES	311,934.00	924,000.00	1,285,000.00	242,000.00	1,043,000.00	0.00	100.00
226-9226-98400	EQUIPMENT	106,286.67	236,000.00	236,000.00	185,335.82	0.00	50,664.18	78.53
226-9226-99400	LEASE PRINCIPAL	1,060,745.00	1,095,886.00	1,095,886.00	1,095,885.85	0.00	0.15	100.00
226-9226-99401	LEASE INTEREST	147,703.39	112,563.00	112,563.00	112,562.54	0.00	0.46	100.00
Net - Dept 9226 - SANITATION EXPENDITURES		(10,126,899.65)	(13,451,831.00)	(13,918,631.00)	(8,426,636.64)	(1,270,052.20)	(4,221,942.16)	
TOTAL REVENUES		12,791,601.14	13,451,831.00	13,918,631.00	10,742,407.34	0.00	3,176,223.66	77.18
TOTAL EXPENDITURES		10,126,899.65	13,451,831.00	13,918,631.00	8,426,636.64	1,270,052.20	4,221,942.16	69.67
NET OF REVENUES & EXPENDITURES		2,664,701.49	0.00	0.00	2,315,770.70	(1,270,052.20)	(1,045,718.50)	100.00
Fund 230 - RENTAL ORDINANCE REVENUE								
Dept 0080 - REVENUES								
230-0080-63401	RESIDENTIAL INSP FEES	1,118,685.00	1,050,000.00	1,050,000.00	914,220.00	0.00	135,780.00	87.07
230-0080-63402	APARTMENT INSPECTION FEE	29,825.00	145,000.00	145,000.00	119,940.00	0.00	25,060.00	82.72
230-0080-66500	INTEREST ON INVESTMENTS	87,811.98	66,000.00	66,000.00	102,110.62	0.00	(36,110.62)	154.71
230-0080-69901	FUND BALANCE APPROPRIATED	0.00	0.00	14,600.00	0.00	0.00	14,600.00	0.00
Net - Dept 0080 - REVENUES		1,236,321.98	1,261,000.00	1,275,600.00	1,136,270.62	0.00	139,329.38	
Dept 9230 - RENTAL ORDIN EXPENDITURES								
230-9230-70600	PERMANENT EMPLOYEES	372,504.76	397,920.00	397,920.00	314,735.85	0.00	83,184.15	79.10
230-9230-70700	TEMPORARY EMPLOYEES	34,012.80	80,000.00	80,000.00	22,649.00	0.00	57,351.00	28.31
230-9230-70705	TEMPORARY - INSPECTION	136,489.05	200,000.00	200,000.00	71,482.50	0.00	128,517.50	35.74
230-9230-70902	OVERTIME - CLERICAL	1,430.11	10,000.00	10,000.00	625.11	0.00	9,374.89	6.25
230-9230-71303	CLEAN/CLOTHING ALLOWANCE	2,100.00	2,100.00	2,100.00	2,100.00	0.00	0.00	100.00
230-9230-71500	SOCIAL SECURITY	42,863.52	54,724.00	54,724.00	32,027.24	0.00	22,696.76	58.53
230-9230-71900	EMPLOYEE INSURANCES	105,015.58	150,753.00	150,753.00	97,438.63	0.00	53,314.37	64.63
230-9230-71904	RETIREE HEALTH INSURANCE	22,837.00	22,837.00	22,837.00	19,030.00	0.00	3,807.00	83.33
230-9230-71905	H.S.A. EXPENSE	7,963.92	8,709.00	8,709.00	6,618.46	0.00	2,090.54	76.00
230-9230-71906	SUPPL LIFE INSURANCE EXP	482.46	776.00	776.00	322.50	0.00	453.50	41.56
230-9230-72100	LONGEVITY	7,231.82	8,814.00	8,814.00	8,762.02	0.00	51.98	99.41
230-9230-72101	BONUS/SICK REDEMPTION	14,081.74	16,428.00	16,428.00	4,644.79	0.00	11,783.21	28.27

REVENUE AND EXPENDITURE REPORT

PERIOD ENDING 04/30/2024

% Fiscal Year Completed: 83.33

GL NUMBER	DESCRIPTION	END BALANCE	2023-24		YTD BALANCE	ENCUMBERED	UNENCUMBERED	% BDGT
		06/30/2023	ORIGINAL	2023-24	04/30/2024			
		NORM (ABNORM)	BUDGET	AMENDED BUDGET	NORM (ABNORM)	YEAR-TO-DATE	BALANCE	USED
Fund 230 - RENTAL ORDINANCE REVENUE								
230-9230-72201	DEFINED CONTRIBUTION EXP	39,819.42	43,529.00	43,529.00	33,092.15	0.00	10,436.85	76.02
230-9230-72501	FEES & PER DIEM	0.00	1,800.00	1,800.00	0.00	0.00	1,800.00	0.00
230-9230-72700	OFFICE SUPPLIES	9,331.47	12,300.00	12,300.00	7,436.95	3,969.99	893.06	92.74
230-9230-80100	CONTRACTUAL SERVICES	0.00	5,000.00	5,000.00	0.00	0.00	5,000.00	0.00
230-9230-80200	POSTAGE	12,401.78	13,200.00	13,200.00	10,317.39	0.00	2,882.61	78.16
230-9230-85300	TELEPHONE & RADIO	339.29	1,000.00	1,000.00	284.50	0.00	715.50	28.45
230-9230-86300	VEHICLE MAINTENANCE	6,807.22	15,000.00	15,000.00	2,922.71	250.00	11,827.29	21.15
230-9230-95000	ADMINISTRATIVE COSTS	90,400.00	93,100.00	93,100.00	77,590.00	0.00	15,510.00	83.34
230-9230-98100	VEHICLES	16,300.00	67,000.00	81,600.00	70,390.00	0.00	11,210.00	86.26
Net - Dept 9230 - COMMUNICATION EXPENDITURE		(922,411.94)	(1,204,990.00)	(1,219,590.00)	(782,469.80)	(4,219.99)	(432,900.21)	
TOTAL REVENUES		1,236,321.98	1,261,000.00	1,275,600.00	1,136,270.62	0.00	139,329.38	89.08
TOTAL EXPENDITURES		922,411.94	1,204,990.00	1,219,590.00	782,469.80	4,219.99	432,900.21	64.50
NET OF REVENUES & EXPENDITURES		313,910.04	56,010.00	56,010.00	353,800.82	(4,219.99)	(293,570.83)	624.14
Fund 250 - COMMUNICATIONS								
Dept 0080 - REVENUES								
250-0080-66500	INTEREST ON INVESTMENTS	81,020.23	65,000.00	65,000.00	75,124.49	0.00	(10,124.49)	115.58
250-0080-66801	LEASE PROCEEDS	0.00	0.00	0.00	13,147.50	0.00	(13,147.50)	100.00
250-0080-66810	CABLE TV FRANCHISE FEES	1,707,103.40	1,840,066.00	1,840,066.00	892,766.07	0.00	947,299.93	48.52
250-0080-67900	MISCELLANEOUS REVENUE	17,782.50	200.00	200.00	13.50	0.00	186.50	6.75
250-0080-69901	FUND BALANCE APPROPRIATED	0.00	605,748.00	684,420.00	0.00	0.00	684,420.00	0.00
Net - Dept 0080 - REVENUES		1,805,906.13	2,511,014.00	2,589,686.00	981,051.56	0.00	1,608,634.44	
Dept 9250 - COMMUNICATION EXPENDITURE								
250-9250-70600	PERMANENT EMPLOYEES	341,466.21	431,971.00	431,971.00	325,863.68	0.00	106,107.32	75.44
250-9250-70700	TEMPORARY EMPLOYEES	167,551.54	300,000.00	300,000.00	76,880.18	0.00	223,119.82	25.63
250-9250-70900	OVERTIME	1,353.48	7,613.00	7,613.00	5,783.54	0.00	1,829.46	75.97
250-9250-71302	EDUCATION ALLOWANCE	2,000.00	3,500.00	3,500.00	3,000.00	0.00	500.00	85.71
250-9250-71303	CLEAN/CLOTHING ALLOWANCE	1,850.00	2,100.00	2,100.00	1,750.00	0.00	350.00	83.33
250-9250-71500	SOCIAL SECURITY	39,312.02	58,925.00	58,925.00	31,890.74	0.00	27,034.26	54.12
250-9250-71900	EMPLOYEE INSURANCES	82,071.88	193,132.00	193,132.00	76,018.86	0.00	117,113.14	39.36
250-9250-71904	RETIREE HEALTH INSURANCE	68,511.00	68,511.00	68,511.00	57,090.00	0.00	11,421.00	83.33
250-9250-71905	H.S.A. EXPENSE	5,585.63	7,842.00	7,842.00	5,702.37	0.00	2,139.63	72.72
250-9250-71906	SUPPL LIFE INSURANCE EXP	48.00	720.00	720.00	49.04	0.00	670.96	6.81
250-9250-72100	LONGEVITY	6,621.50	8,202.00	8,202.00	6,718.14	0.00	1,483.86	81.91
250-9250-72101	BONUS/SICK REDEMPTION	0.00	16,774.00	16,774.00	3,789.99	0.00	12,984.01	22.59
250-9250-72200	RETIREMENT FUND	62,217.00	57,278.00	57,278.00	47,730.00	0.00	9,548.00	83.33
250-9250-72201	DEFINED CONTRIBUTION EXP	35,252.83	47,020.00	47,020.00	34,690.04	0.00	12,329.96	73.78
250-9250-72700	OFFICE SUPPLIES	1,449.92	3,500.00	3,500.00	870.83	280.93	2,348.24	32.91
250-9250-74000	OPERATING SUPPLIES	15,753.29	20,000.00	23,570.00	17,856.40	909.31	4,804.29	79.62
250-9250-74001	TAPES	1,989.96	2,000.00	2,000.00	699.00	0.00	1,301.00	34.95
250-9250-80100	CONTRACTUAL SERVICES	42,543.34	90,000.00	90,000.00	33,370.07	8,786.36	47,843.57	46.84
250-9250-80147	SOFTWARE & CONTR SERVICE	46,974.24	55,000.00	55,000.00	45,139.93	0.00	9,860.07	82.07
250-9250-80200	POSTAGE	12,767.50	15,000.00	15,000.00	13,307.97	0.00	1,692.03	88.72
250-9250-80301	UNEMPLOYMENT COSTS	0.00	5,000.00	5,000.00	0.00	0.00	5,000.00	0.00
250-9250-85300	TELEPHONE & RADIO	4,296.08	7,000.00	7,000.00	2,449.34	53.99	4,496.67	35.76
250-9250-86300	VEHICLE MAINTENANCE	2,802.50	4,000.00	4,000.00	2,119.02	0.00	1,880.98	52.98
250-9250-86400	CONFERENCES & WORKSHOPS	145.00	3,500.00	3,500.00	0.00	0.00	3,500.00	0.00
250-9250-88001	COMMUNITY PROMOTION/OUTREACH F	14,037.73	15,000.00	15,000.00	9,495.01	3,242.03	2,262.96	84.91

REVENUE AND EXPENDITURE REPORT

PERIOD ENDING 04/30/2024

% Fiscal Year Completed: 83.33

GL NUMBER	DESCRIPTION	END BALANCE	2023-24		YTD BALANCE	ENCUMBERED	UNENCUMBERED	% BGD
		06/30/2023	ORIGINAL	2023-24	04/30/2024			
		NORM (ABNORM)	BUDGET	AMENDED BUDGET	NORM (ABNORM)	YEAR-TO-DATE	BALANCE	USED
Fund 250 - COMMUNICATIONS								
250-9250-88006	SETS & DESIGN	0.00	3,000.00	3,000.00	0.00	2,755.91	244.09	91.86
250-9250-88007	WEB SITE	9,402.43	25,000.00	25,000.00	13,488.00	7,500.00	4,012.00	83.95
250-9250-88008	CITY CALENDAR	45,757.80	50,000.00	50,000.00	31,559.19	0.00	18,440.81	63.12
250-9250-88009	MUSIC LIBRARY	2,000.00	2,000.00	2,000.00	2,000.00	0.00	0.00	100.00
250-9250-88010	AUDITORIUM EXPENSE	16,754.18	25,000.00	27,520.00	14,317.89	3,411.79	9,790.32	64.42
250-9250-91000	INSURANCE & BONDS	46,900.00	48,700.00	48,700.00	40,590.00	0.00	8,110.00	83.35
250-9250-92000	PUBLIC UTILITIES	104,090.45	115,000.00	115,000.00	82,517.70	0.00	32,482.30	71.75
250-9250-95000	ADMINISTRATIVE COSTS	371,300.00	382,400.00	382,400.00	318,670.00	0.00	63,730.00	83.33
250-9250-95800	MEMBERSHIPS & DUES	700.00	13,700.00	13,700.00	13,235.00	0.00	465.00	96.61
250-9250-96470	TRANS TO FUND 386 BOND PMT	351,018.62	357,626.00	357,626.00	357,624.06	0.00	1.94	100.00
250-9250-98100	VEHICLES	0.00	35,000.00	35,000.00	0.00	0.00	35,000.00	0.00
250-9250-98412	CABLE TV EQUIPMENT	77,358.78	30,000.00	102,582.00	55,399.64	24,335.00	22,847.36	77.73
Net - Dept 9250 - COMMUNICATION EXPENDITURE		(1,981,882.91)	(2,511,014.00)	(2,589,686.00)	(1,731,665.63)	(51,275.32)	(806,745.05)	
TOTAL REVENUES		1,805,906.13	2,511,014.00	2,589,686.00	981,051.56	0.00	1,608,634.44	37.88
TOTAL EXPENDITURES		1,981,882.91	2,511,014.00	2,589,686.00	1,731,665.63	51,275.32	806,745.05	68.85
NET OF REVENUES & EXPENDITURES		(175,976.78)	0.00	0.00	(750,614.07)	(51,275.32)	801,889.39	100.00
Fund 259 - INDIGENT DEFENSE FUND								
Dept 0080 - REVENUES								
259-0080-53901	INDIGENT DEFENSE GRANT	377,565.01	0.00	3,429,761.03	1,806,886.18	0.00	1,622,874.85	52.68
259-0080-66500	INTEREST ON INVESTMENTS	20,209.85	0.00	0.00	31,295.18	0.00	(31,295.18)	100.00
259-0080-69501	TRANSFER FROM GEN FUND	123,769.06	0.00	123,769.06	123,769.06	0.00	0.00	100.00
259-0080-69901	FUND BALANCE APPROPRIATED	0.00	0.00	408,077.40	0.00	0.00	408,077.40	0.00
Net - Dept 0080 - REVENUES		521,543.92	0.00	3,961,607.49	1,961,950.42	0.00	1,999,657.07	
Dept 9259 - INDIGENT DEFENSE EXPENDITURES								
259-9259-70600	PERMANENT EMPLOYEES	53,517.73	0.00	77,089.40	46,412.77	0.00	30,676.63	60.21
259-9259-71500	SOCIAL SECURITY	4,225.69	0.00	5,869.01	3,550.43	0.00	2,318.58	60.49
259-9259-71900	EMPLOYEE INSURANCES	6,330.55	0.00	23,664.94	9,949.05	0.00	13,715.89	42.04
259-9259-71905	H.S.A. EXPENSE	1,130.47	0.00	1,541.79	953.28	0.00	588.51	61.83
259-9259-72201	DEFINED CONTRIBUTION EXP	5,651.86	0.00	7,708.89	4,766.35	0.00	2,942.54	61.83
259-9259-72700	OFFICE SUPPLIES	3,078.01	0.00	4,200.00	2,754.34	94.56	1,351.10	67.83
259-9259-80100	CONTRACTUAL SERVICES	0.00	0.00	19,136.98	1,301.25	0.00	17,835.73	6.80
259-9259-80301	UNEMPLOYMENT COSTS	0.00	0.00	600.41	0.00	0.00	600.41	0.00
259-9259-82601	COUNSEL FOR INDIGENTS	732,234.96	0.00	3,821,796.07	805,896.55	0.00	3,015,899.52	21.09
Net - Dept 9259 - INDIGENT DEFENSE EXPENDITURES		(806,169.27)	0.00	(3,961,607.49)	(875,584.02)	(94.56)	(3,085,928.91)	
TOTAL REVENUES		521,543.92	0.00	3,961,607.49	1,961,950.42	0.00	1,999,657.07	49.52
TOTAL EXPENDITURES		806,169.27	0.00	3,961,607.49	875,584.02	94.56	3,085,928.91	22.10
NET OF REVENUES & EXPENDITURES		(284,625.35)	0.00	0.00	1,086,366.40	(94.56)	(1,086,271.84)	100.00
Fund 260 - VICE CRIME CONFISCATION								
Dept 0080 - REVENUES								
260-0080-66000	VICE CRIME CONFISCATIONS	28,290.35	59,000.00	59,000.00	51,822.78	0.00	7,177.22	87.84

REVENUE AND EXPENDITURE REPORT

PERIOD ENDING 04/30/2024

% Fiscal Year Completed: 83.33

GL NUMBER	DESCRIPTION	END BALANCE	2023-24		YTD BALANCE	ENCUMBERED	UNENCUMBERED	% BDGT
		06/30/2023	ORIGINAL	2023-24	04/30/2024			
		NORM (ABNORM)	BUDGET	AMENDED BUDGET	NORM (ABNORM)	YEAR-TO-DATE	BALANCE	USED
Fund 260 - VICE CRIME CONFISCATION								
260-0080-66500	INTEREST ON INVESTMENTS	15,822.95	1,000.00	1,000.00	17,261.32	0.00	(16,261.32)	1,726.13
Net - Dept 0080 - REVENUES		44,113.30	60,000.00	60,000.00	69,084.10	0.00	(9,084.10)	
Dept 9260 - VICE CRIME EXPENDITURES								
260-9260-82211	VICE CRIME EXPENDITURES	21,960.26	60,000.00	60,000.00	24,630.90	608.00	34,761.10	42.06
Net - Dept 9260 - VICE CRIME EXPENDITURES		(21,960.26)	(60,000.00)	(60,000.00)	(24,630.90)	(608.00)	(34,761.10)	
TOTAL REVENUES		44,113.30	60,000.00	60,000.00	69,084.10	0.00	(9,084.10)	115.14
TOTAL EXPENDITURES		21,960.26	60,000.00	60,000.00	24,630.90	608.00	34,761.10	42.06
NET OF REVENUES & EXPENDITURES		22,153.04	0.00	0.00	44,453.20	(608.00)	(43,845.20)	100.00
Fund 261 - DRUG FORFEITURE FUND								
Dept 0080 - REVENUES								
261-0080-66100	FED DRUG FORFEITURES JUSTICE	378,852.76	150,000.00	150,000.00	413,481.93	0.00	(263,481.93)	275.65
261-0080-66101	FED DRUG FORFEITURES TREASURY	47,844.70	0.00	0.00	0.00	0.00	0.00	0.00
261-0080-66102	LOCAL DRUG FORFEITURES	535,226.84	375,000.00	375,000.00	325,067.96	0.00	49,932.04	86.68
261-0080-66500	INTEREST ON INVESTMENTS	72,181.45	7,500.00	7,500.00	69,569.76	0.00	(62,069.76)	927.60
261-0080-69901	FUND BALANCE APPROPRIATED	0.00	7,500.00	1,155,694.00	0.00	0.00	1,155,694.00	0.00
Net - Dept 0080 - REVENUES		1,034,105.75	540,000.00	1,688,194.00	808,119.65	0.00	880,074.35	
Dept 9261 - DRUG FORFEIT EXPENDITURES								
261-9261-82214	FED JUSTICE FORFEITURE EXP	475,317.00	240,000.00	242,705.00	159,978.00	1,050.00	81,677.00	66.35
261-9261-82215	LOCAL DRUG FORFEITURE EXP	620,789.89	300,000.00	1,445,489.00	1,022,808.37	79,543.45	343,137.18	76.26
Net - Dept 9261 - DRUG FORFEIT EXPENDITURES		(1,096,106.89)	(540,000.00)	(1,688,194.00)	(1,182,786.37)	(80,593.45)	(424,814.18)	
TOTAL REVENUES		1,034,105.75	540,000.00	1,688,194.00	808,119.65	0.00	880,074.35	47.87
TOTAL EXPENDITURES		1,096,106.89	540,000.00	1,688,194.00	1,182,786.37	80,593.45	424,814.18	74.84
NET OF REVENUES & EXPENDITURES		(62,001.14)	0.00	0.00	(374,666.72)	(80,593.45)	455,260.17	100.00
Fund 262 - POLICE TRAINING FUND								
Dept 0080 - REVENUES								
262-0080-54400	POLICE TRAINING	47,452.14	22,000.00	72,000.00	78,593.82	0.00	(6,593.82)	109.16
262-0080-66500	INTEREST ON INVESTMENTS	1,390.35	250.00	250.00	2,619.52	0.00	(2,369.52)	1,047.81
262-0080-69901	FUND BALANCE APPROPRIATED	0.00	2,750.00	2,750.00	0.00	0.00	2,750.00	0.00
Net - Dept 0080 - REVENUES		48,842.49	25,000.00	75,000.00	81,213.34	0.00	(6,213.34)	
Dept 9262 - POLICE TRAINING EXPEND								
262-9262-86400	CONFERENCES & WORKSHOPS	19,235.31	25,000.00	75,000.00	25,976.80	39,337.34	9,685.86	87.09
Net - Dept 9262 - POLICE TRAINING EXPEND		(19,235.31)	(25,000.00)	(75,000.00)	(25,976.80)	(39,337.34)	(9,685.86)	

REVENUE AND EXPENDITURE REPORT

PERIOD ENDING 04/30/2024

% Fiscal Year Completed: 83.33

GL NUMBER	DESCRIPTION	END BALANCE	2023-24		YTD BALANCE	ENCUMBERED	UNENCUMBERED	% BDGT
		06/30/2023	ORIGINAL	2023-24	04/30/2024			
		NORM (ABNORM)	BUDGET	AMENDED BUDGET	NORM (ABNORM)	YEAR-TO-DATE	BALANCE	USED
Fund 262 - POLICE TRAINING FUND								
TOTAL REVENUES		48,842.49	25,000.00	75,000.00	81,213.34	0.00	(6,213.34)	108.28
TOTAL EXPENDITURES		19,235.31	25,000.00	75,000.00	25,976.80	39,337.34	9,685.86	87.09
NET OF REVENUES & EXPENDITURES		29,607.18	0.00	0.00	55,236.54	(39,337.34)	(15,899.20)	100.00
Fund 271 - LIBRARY SPECIAL REVENUE								
Dept 0080 - REVENUES								
271-0080-40300	TAX COLLECTIONS	823.73	0.00	0.00	727.68	0.00	(727.68)	100.00
271-0080-40302	PROPERTY TAX: LIBRARY	4,872,680.64	5,151,461.00	5,151,461.00	4,317,316.46	0.00	834,144.54	83.81
271-0080-43702	IF TAX: LIBRARY	32,139.79	65,560.00	65,560.00	54,630.00	0.00	10,930.00	83.33
271-0080-50512	EMERGENCY CONNECTIVITY GRANT E	16,309.37	0.00	0.00	0.00	0.00	0.00	0.00
271-0080-52800	OTHER FEDERAL GRANTS COVID19/A	0.00	0.00	2,000,000.00	0.00	0.00	2,000,000.00	0.00
271-0080-54200	STATE AID	141,348.44	90,000.00	90,000.00	70,178.28	0.00	19,821.72	77.98
271-0080-57300	LOCAL COMM STABILIZ SHARE	530,017.64	250,000.00	250,000.00	274,647.23	0.00	(24,647.23)	109.86
271-0080-57500	RENAISSANCE ZONE REIMB	0.00	17,000.00	17,000.00	0.00	0.00	17,000.00	0.00
271-0080-62611	COPY MACHINE REVENUE	26,429.20	30,000.00	30,000.00	24,807.24	0.00	5,192.76	82.69
271-0080-62613	VIDEO CASSETTE USER FEES	1,069.29	2,000.00	2,000.00	811.01	0.00	1,188.99	40.55
271-0080-62615	NON-RESIDENT INTERNET FEE	2,613.00	8,000.00	8,000.00	2,248.00	0.00	5,752.00	28.10
271-0080-65105	NON-RESIDENT ROOM USE	648.05	0.00	0.00	1,030.00	0.00	(1,030.00)	100.00
271-0080-65600	LIBRARY - PENAL FINES	91,246.84	117,000.00	117,000.00	0.00	0.00	117,000.00	0.00
271-0080-65700	LIBRARY FINES	12,304.45	25,000.00	25,000.00	9,194.75	0.00	15,805.25	36.78
271-0080-65900	LOST BOOK REVENUE	8,393.39	11,000.00	11,000.00	9,207.38	0.00	1,792.62	83.70
271-0080-66500	INTEREST ON INVESTMENTS	205,101.40	15,000.00	15,000.00	252,455.18	0.00	(237,455.18)	1,683.03
271-0080-67300	SALE OF EQUIPMENT	4,100.00	0.00	0.00	0.00	0.00	0.00	0.00
271-0080-67350	SALE OF PROPERTY	0.00	0.00	0.00	94,922.61	0.00	(94,922.61)	100.00
271-0080-67900	MISCELLANEOUS REVENUE	20,789.81	10,500.00	10,500.00	112,459.18	0.00	(101,959.18)	1,071.04
271-0080-67907	DONATIONS	95.20	0.00	0.00	121.14	0.00	(121.14)	100.00
271-0080-69901	FUND BALANCE APPROPRIATED	0.00	0.00	199,196.00	0.00	0.00	199,196.00	0.00
Net - Dept 0080 - REVENUES		5,966,110.24	5,792,521.00	7,991,717.00	5,224,756.14	0.00	2,766,960.86	
Dept 9271 - LIBRARY EXPENDITURES								
271-9271-70300	APPOINTED OFFICIAL	110,290.77	113,605.00	113,605.00	90,966.43	0.00	22,638.57	80.07
271-9271-70600	PERMANENT EMPLOYEES	1,392,149.67	1,491,091.00	1,478,091.00	1,150,341.86	0.00	327,749.14	77.83
271-9271-70714	PERMANENT PART-TIME EMP	150,913.80	300,000.00	300,000.00	144,155.25	0.00	155,844.75	48.05
271-9271-70900	OVERTIME	316.60	20,000.00	20,000.00	222.30	0.00	19,777.70	1.11
271-9271-71000	SHIFT PREMIUM	9,909.75	15,500.00	15,500.00	6,845.27	0.00	8,654.73	44.16
271-9271-71302	EDUCATION ALLOWANCE	17,900.00	26,500.00	26,500.00	22,000.00	0.00	4,500.00	83.02
271-9271-71303	CLEAN/CLOTHING ALLOWANCE	7,650.00	8,400.00	8,575.00	8,575.00	0.00	0.00	100.00
271-9271-71500	SOCIAL SECURITY	131,794.22	158,537.00	158,537.00	112,271.19	0.00	46,265.81	70.82
271-9271-71900	EMPLOYEE INSURANCES	335,612.10	465,290.00	465,290.00	330,533.35	0.00	134,756.65	71.04
271-9271-71904	RETIREE HEALTH INSURANCE	182,696.00	182,696.00	182,696.00	152,250.00	0.00	30,446.00	83.34
271-9271-71905	H.S.A. EXPENSE	24,036.66	26,977.00	26,977.00	20,106.20	0.00	6,870.80	74.53
271-9271-71906	SUPPL LIFE INSURANCE EXP	1,978.50	2,328.00	2,328.00	1,784.44	0.00	543.56	76.65
271-9271-72100	LONGEVITY	38,094.58	43,755.00	43,755.00	31,132.96	0.00	12,622.04	71.15
271-9271-72101	BONUS/SICK REDEMPTION	18,752.67	53,228.00	53,228.00	29,424.73	0.00	23,803.27	55.28
271-9271-72200	RETIREMENT FUND	373,308.00	343,668.00	343,668.00	286,390.00	0.00	57,278.00	83.33
271-9271-72201	DEFINED CONTRIBUTION EXP	144,342.34	171,579.00	171,579.00	121,444.50	0.00	50,134.50	70.78
271-9271-72700	OFFICE SUPPLIES	58,320.67	97,600.00	97,600.00	45,370.29	26,465.39	25,764.32	73.60
271-9271-72702	COPY MACHINE EXPENSE	8,976.24	20,000.00	20,000.00	5,244.37	7,396.25	7,359.38	63.20
271-9271-80100	CONTRACTUAL SERVICES	204,845.98	310,700.00	345,700.00	172,654.77	35,202.30	137,842.93	60.13
271-9271-80117	COOPERATIVE SERVICES	166,112.77	219,000.00	219,000.00	171,168.39	0.00	47,831.61	78.16
271-9271-80130	LIBRARY COOP INDIRECT AID	70,674.22	69,000.00	75,000.00	0.00	0.00	75,000.00	0.00
271-9271-80200	POSTAGE	215.29	3,000.00	3,000.00	92.56	200.00	2,707.44	9.75

REVENUE AND EXPENDITURE REPORT

PERIOD ENDING 04/30/2024

% Fiscal Year Completed: 83.33

GL NUMBER	DESCRIPTION	END BALANCE	2023-24		YTD BALANCE	ENCUMBERED	UNENCUMBERED	% BDGT
		06/30/2023	ORIGINAL	2023-24	04/30/2024			
		NORM (ABNORM)	BUDGET	AMENDED BUDGET	NORM (ABNORM)	YEAR-TO-DATE	BALANCE	USED
Fund 271 - LIBRARY SPECIAL REVENUE								
271-9271-80301	UNEMPLOYMENT COSTS	0.00	800.00	800.00	724.00	0.00	76.00	90.50
271-9271-82201	DIGITAL VIDEO DISCS	16,099.92	16,100.00	16,100.00	11,825.19	0.00	4,274.81	73.45
271-9271-82202	LIBRARY CIRCULATING MAT	100,999.51	101,000.00	101,000.00	63,166.49	0.00	37,833.51	62.54
271-9271-82207	PERIODICALS	19,291.33	22,000.00	26,000.00	1,187.90	24,761.53	50.57	99.81
271-9271-85300	TELEPHONE & RADIO	16,735.28	30,000.00	30,000.00	5,847.59	42.09	24,110.32	19.63
271-9271-86100	MILEAGE	33.48	200.00	200.00	0.00	0.00	200.00	0.00
271-9271-86300	VEHICLE MAINTENANCE	992.61	3,000.00	3,000.00	650.28	0.00	2,349.72	21.68
271-9271-86400	CONFERENCES & WORKSHOPS	7,218.26	15,000.00	15,000.00	5,931.50	489.00	8,579.50	42.80
271-9271-90200	BOOK BINDING	0.00	100.00	100.00	0.00	0.00	100.00	0.00
271-9271-91000	INSURANCE & BONDS	46,900.00	48,700.00	48,700.00	40,590.00	0.00	8,110.00	83.35
271-9271-92000	PUBLIC UTILITIES	215,900.94	220,000.00	220,000.00	163,963.30	0.00	56,036.70	74.53
271-9271-93000	BUILDING MAINTENANCE	18,720.24	61,500.00	134,291.00	50,747.02	73,886.93	9,657.05	92.81
271-9271-95000	ADMINISTRATIVE COSTS	269,100.00	277,100.00	277,100.00	230,920.00	0.00	46,180.00	83.33
271-9271-96470	TRANS TO FUND 386 BOND PMT	105,305.58	107,289.00	107,289.00	107,287.21	0.00	1.79	100.00
271-9271-97400	CAPITAL IMPROVEMENTS	203,832.48	85,000.00	183,230.00	76,526.71	41,728.00	64,975.29	64.54
271-9271-98000	OFFICE EQUIPMENT	25,783.81	67,000.00	67,000.00	24,089.00	0.00	42,911.00	35.95
271-9271-98100	VEHICLES	27,106.00	0.00	0.00	0.00	0.00	0.00	0.00
271-9271-98200	BOOKS	314,999.80	315,000.00	311,000.00	226,303.93	0.00	84,696.07	72.77
271-9271-98500	ARPA EXPENDITURES	0.00	0.00	2,000,000.00	0.00	0.00	2,000,000.00	0.00
Net - Dept 9271 - LIBRARY EXPENDITURES		(4,837,910.07)	(5,512,243.00)	(7,711,439.00)	(3,912,733.98)	(210,171.49)	(3,588,533.53)	
TOTAL REVENUES		5,966,110.24	5,792,521.00	7,991,717.00	5,224,756.14	0.00	2,766,960.86	65.38
TOTAL EXPENDITURES		4,837,910.07	5,512,243.00	7,711,439.00	3,912,733.98	210,171.49	3,588,533.53	53.46
NET OF REVENUES & EXPENDITURES		1,128,200.17	280,278.00	280,278.00	1,312,022.16	(210,171.49)	(821,572.67)	393.13
Fund 273 - CDBG ENTITLEMENT FUND								
Dept 0080 - REVENUES								
273-0080-53100	DRAWDOWN	1,035,290.25	1,045,620.00	1,045,620.00	625,737.87	0.00	419,882.13	59.84
273-0080-53102	PROGRAM INCOME	437,131.72	372,624.25	(1,330,019.39)	134,327.78	0.00	(1,464,347.17)	(10.10)
273-0080-53118	HUD CARES ACT FUNDING	532,945.29	0.00	53,566.19	66,091.89	0.00	(12,525.70)	123.38
273-0080-66500	INTEREST EARNED	0.00	0.00	0.00	32.72	0.00	(32.72)	100.00
Net - Dept 0080 - REVENUES		2,005,367.26	1,418,244.25	(230,833.20)	826,190.26	0.00	(1,057,023.46)	
Dept 9441 - PUBLIC IMPROVEMENTS								
273-9441-80183	STREET PROGRAM	0.00	331,996.00	0.00	0.00	0.00	0.00	0.00
273-9441-80183-CD1911	STREET PROGRAM	2,320.00	0.00	0.00	0.00	0.00	0.00	0.00
273-9441-80183-CD2013	STREET PROGRAM	103,543.18	0.00	0.00	0.00	0.00	0.00	0.00
273-9441-80183-CD2111	STREET PROGRAM	27,113.82	0.00	0.00	0.00	0.00	0.00	0.00
273-9441-80183-CD2210	STREET PROGRAM	211,881.26	0.00	0.00	0.00	0.00	0.00	0.00
273-9441-80183-CD2311	STREET PROGRAM	0.00	0.00	331,996.00	0.00	1,700.00	330,296.00	0.51
273-9441-88102-CD2013	PROGRAM INCOME EXPENSE	0.00	106,238.53	0.00	0.00	0.00	0.00	0.00
Net - Dept 9441 - PUBLIC IMPROVEMENTS		(344,858.26)	(438,234.53)	(331,996.00)	0.00	(1,700.00)	(330,296.00)	
Dept 9666 - ADMINISTRATIVE COSTS								
273-9666-70600-CD1713	PERMANENT EMPLOYEES	0.00	112,348.12	0.00	0.00	0.00	0.00	0.00
273-9666-70600-CD1812	PERMANENT EMPLOYEES	0.00	90,849.74	0.00	0.00	0.00	0.00	0.00
273-9666-70600-CD1912	PERMANENT EMPLOYEES	0.00	131,480.33	0.00	0.00	0.00	0.00	0.00
273-9666-70600-CD2015	PERMANENT EMPLOYEES	0.00	89,230.63	0.00	0.00	0.00	0.00	0.00

REVENUE AND EXPENDITURE REPORT

PERIOD ENDING 04/30/2024

% Fiscal Year Completed: 83.33

GL NUMBER	DESCRIPTION	END BALANCE	2023-24		YTD BALANCE	ENCUMBERED	UNENCUMBERED	% BGD
		06/30/2023	ORIGINAL	2023-24	04/30/2024			
		NORM (ABNORM)	BUDGET	AMENDED BUDGET	NORM (ABNORM)	YEAR-TO-DATE	BALANCE	USED
Fund 273 - CDBG ENTITLEMENT FUND								
273-9666-70600-CD2115	PERMANENT EMPLOYEES	26,787.30	147,420.15	0.00	0.00	0.00	0.00	0.00
273-9666-70600-CD2213	PERMANENT EMPLOYEES	76,518.11	21,932.53	0.00	0.00	0.00	0.00	0.00
273-9666-70712-CD1713	TEMPORARY - PLANNING AIDE	0.00	16,238.02	0.00	0.00	0.00	0.00	0.00
273-9666-70712-CD1812	TEMPORARY - PLANNING AIDE	0.00	15,377.53	0.00	0.00	0.00	0.00	0.00
273-9666-70712-CD1912	TEMPORARY - PLANNING AIDE	0.00	13,435.00	0.00	0.00	0.00	0.00	0.00
273-9666-70712-CD2015	TEMPORARY - PLANNING AIDE	0.00	19,650.00	0.00	0.00	0.00	0.00	0.00
273-9666-70712-CD2115	TEMPORARY - PLANNING AIDE	(146.25)	66,158.25	0.00	0.00	0.00	0.00	0.00
273-9666-70712-CD2213	TEMPORARY - PLANNING AIDE	6,750.00	6,175.00	0.00	0.00	0.00	0.00	0.00
273-9666-71302-CD1713	EDUCATION ALLOWANCE	0.00	1,150.00	0.00	0.00	0.00	0.00	0.00
273-9666-71302-CD1812	EDUCATION ALLOWANCE	0.00	2,350.00	0.00	0.00	0.00	0.00	0.00
273-9666-71302-CD1912	EDUCATION ALLOWANCE	0.00	2,350.00	0.00	0.00	0.00	0.00	0.00
273-9666-71302-CD2015	EDUCATION ALLOWANCE	0.00	2,350.00	0.00	0.00	0.00	0.00	0.00
273-9666-71302-CD2115	EDUCATION ALLOWANCE	0.00	800.00	0.00	0.00	0.00	0.00	0.00
273-9666-71302-CD2213	EDUCATION ALLOWANCE	1,400.00	1,500.00	0.00	0.00	0.00	0.00	0.00
273-9666-71303-CD2213	CLEAN/CLOTHING ALLOWANCE	700.00	350.00	0.00	0.00	0.00	0.00	0.00
273-9666-71500-CD1713	SOCIAL SECURITY	0.00	9,209.60	0.00	0.00	0.00	0.00	0.00
273-9666-71500-CD1812	SOCIAL SECURITY	0.00	7,378.80	0.00	0.00	0.00	0.00	0.00
273-9666-71500-CD1912	SOCIAL SECURITY	0.00	9,539.84	0.00	0.00	0.00	0.00	0.00
273-9666-71500-CD2015	SOCIAL SECURITY	0.00	4,859.60	0.00	0.00	0.00	0.00	0.00
273-9666-71500-CD2115	SOCIAL SECURITY	2,377.93	11,559.29	0.00	0.00	0.00	0.00	0.00
273-9666-71500-CD2213	SOCIAL SECURITY	7,518.24	182.76	0.00	0.00	0.00	0.00	0.00
273-9666-71900-CD2115	EMPLOYEE INSURANCES	629.40	10,002.11	0.00	0.00	0.00	0.00	0.00
273-9666-71900-CD2213	EMPLOYEE INSURANCES	49,703.15	0.00	0.00	0.00	0.00	0.00	0.00
273-9666-71904-CD1713	RETIREE HEALTH INSURANCE	0.00	67,169.12	0.00	0.00	0.00	0.00	0.00
273-9666-71904-CD1812	RETIREE HEALTH INSURANCE	0.00	13,985.33	0.00	0.00	0.00	0.00	0.00
273-9666-71904-CD1912	RETIREE HEALTH INSURANCE	0.00	12,356.53	0.00	0.00	0.00	0.00	0.00
273-9666-71904-CD2015	RETIREE HEALTH INSURANCE	0.00	18,781.32	0.00	0.00	0.00	0.00	0.00
273-9666-71904-CD2115	RETIREE HEALTH INSURANCE	0.00	20,591.15	0.00	0.00	0.00	0.00	0.00
273-9666-71904-CD2213	RETIREE HEALTH INSURANCE	(10,585.03)	34,585.03	0.00	0.00	0.00	0.00	0.00
273-9666-71905-CD2213	H.S.A. EXPENSE	105.00	0.00	0.00	0.00	0.00	0.00	0.00
273-9666-71906-CD1713	SUPPL LIFE INSURANCE EXP	0.00	269.40	0.00	0.00	0.00	0.00	0.00
273-9666-71906-CD1812	SUPPL LIFE INSURANCE EXP	0.00	236.40	0.00	0.00	0.00	0.00	0.00
273-9666-71906-CD1912	SUPPL LIFE INSURANCE EXP	0.00	300.00	0.00	0.00	0.00	0.00	0.00
273-9666-71906-CD2015	SUPPL LIFE INSURANCE EXP	0.00	175.20	0.00	0.00	0.00	0.00	0.00
273-9666-71906-CD2115	SUPPL LIFE INSURANCE EXP	60.00	240.00	0.00	0.00	0.00	0.00	0.00
273-9666-71906-CD2213	SUPPL LIFE INSURANCE EXP	0.00	300.00	0.00	0.00	0.00	0.00	0.00
273-9666-72100-CD1713	LONGEVITY	0.00	4,400.00	0.00	0.00	0.00	0.00	0.00
273-9666-72100-CD1812	LONGEVITY	0.00	8,345.89	0.00	0.00	0.00	0.00	0.00
273-9666-72100-CD1912	LONGEVITY	0.00	6,744.98	0.00	0.00	0.00	0.00	0.00
273-9666-72100-CD2015	LONGEVITY	0.00	7,624.00	0.00	0.00	0.00	0.00	0.00
273-9666-72100-CD2115	LONGEVITY	0.00	9,773.82	0.00	0.00	0.00	0.00	0.00
273-9666-72100-CD2213	LONGEVITY	8,282.32	1,317.68	0.00	0.00	0.00	0.00	0.00
273-9666-72201-CD1713	DEFINED CONTRIBUTION EXP	0.00	15,479.81	0.00	0.00	0.00	0.00	0.00
273-9666-72201-CD1812	DEFINED CONTRIBUTION EXP	0.00	13,904.13	0.00	0.00	0.00	0.00	0.00
273-9666-72201-CD1912	DEFINED CONTRIBUTION EXP	0.00	18,782.94	0.00	0.00	0.00	0.00	0.00
273-9666-72201-CD2015	DEFINED CONTRIBUTION EXP	0.00	13,754.51	0.00	0.00	0.00	0.00	0.00
273-9666-72201-CD2115	DEFINED CONTRIBUTION EXP	4,993.52	18,652.20	0.00	0.00	0.00	0.00	0.00
273-9666-72201-CD2213	DEFINED CONTRIBUTION EXP	10,782.36	3,924.73	0.00	0.00	0.00	0.00	0.00
273-9666-72700-CD1713	OFFICE SUPPLIES	0.00	468.99	0.00	0.00	0.00	0.00	0.00
273-9666-72700-CD1812	OFFICE SUPPLIES	0.00	958.35	0.00	0.00	0.00	0.00	0.00
273-9666-72700-CD2115	OFFICE SUPPLIES	368.00	627.05	0.00	0.00	0.00	0.00	0.00
273-9666-72700-CD2213	OFFICE SUPPLIES	118.84	2,881.16	0.00	0.00	0.00	0.00	0.00
273-9666-72702-CD1713	COPY MACHINE EXPENSE	0.00	790.36	0.00	0.00	0.00	0.00	0.00
273-9666-72702-CD1812	COPY MACHINE EXPENSE	0.00	357.63	0.00	0.00	0.00	0.00	0.00
273-9666-72702-CD1912	COPY MACHINE EXPENSE	0.00	933.60	0.00	0.00	0.00	0.00	0.00
273-9666-72702-CD2015	COPY MACHINE EXPENSE	0.00	208.13	0.00	0.00	0.00	0.00	0.00
273-9666-72702-CD2115	COPY MACHINE EXPENSE	223.56	271.80	0.00	0.00	0.00	0.00	0.00

REVENUE AND EXPENDITURE REPORT

PERIOD ENDING 04/30/2024

% Fiscal Year Completed: 83.33

GL NUMBER	DESCRIPTION	END BALANCE	2023-24		YTD BALANCE	ENCUMBERED	UNENCUMBERED	% BGD
		06/30/2023	ORIGINAL	2023-24	04/30/2024			
		NORM (ABNORM)	BUDGET	AMENDED BUDGET	NORM (ABNORM)	YEAR-TO-DATE	BALANCE	USED
Fund 273 - CDBG ENTITLEMENT FUND								
273-9666-72702-CD2213	COPY MACHINE EXPENSE	1,216.31	0.00	0.00	0.00	0.00	0.00	0.00
273-9666-80105-CD1713	INDEPENDENT AUDIT	0.00	3,690.00	0.00	0.00	0.00	0.00	0.00
273-9666-80105-CD1812	INDEPENDENT AUDIT	0.00	3,920.00	0.00	0.00	0.00	0.00	0.00
273-9666-80105-CD2115	INDEPENDENT AUDIT	8,250.00	4,730.00	0.00	0.00	0.00	0.00	0.00
273-9666-80105-CD2213	INDEPENDENT AUDIT	5,650.00	14,350.00	0.00	0.00	0.00	0.00	0.00
273-9666-80111	FAIR HOUSING ACTIVITY	0.00	500.00	0.00	0.00	0.00	0.00	0.00
273-9666-80111-CD2214	FAIR HOUSING ACTIVITY	500.00	0.00	0.00	0.00	0.00	0.00	0.00
273-9666-80111-CD2314	FAIR HOUSING ACTIVITY	0.00	0.00	500.00	0.00	0.00	500.00	0.00
273-9666-86100-CD1713	MILEAGE	0.00	750.00	0.00	0.00	0.00	0.00	0.00
273-9666-86100-CD1812	MILEAGE	0.00	250.00	0.00	0.00	0.00	0.00	0.00
273-9666-86100-CD1912	MILEAGE	0.00	100.00	0.00	0.00	0.00	0.00	0.00
273-9666-86100-CD2015	MILEAGE	0.00	200.00	0.00	0.00	0.00	0.00	0.00
273-9666-86100-CD2115	MILEAGE	0.00	200.00	0.00	0.00	0.00	0.00	0.00
273-9666-86100-CD2213	MILEAGE	0.00	118.00	0.00	0.00	0.00	0.00	0.00
273-9666-86400-CD1912	CONFERENCES & WORKSHOPS	0.00	824.00	0.00	0.00	0.00	0.00	0.00
273-9666-86400-CD2115	CONFERENCES & WORKSHOPS	629.00	571.00	0.00	0.00	0.00	0.00	0.00
273-9666-86400-CD2213	CONFERENCES & WORKSHOPS	0.00	1,000.00	0.00	0.00	0.00	0.00	0.00
273-9666-88102-CD1713	PROGRAM INCOME EXPENSE	0.00	30,000.00	0.00	0.00	0.00	0.00	0.00
273-9666-88102-CD1812	PROGRAM INCOME EXPENSE	0.00	29,954.87	0.00	0.00	0.00	0.00	0.00
273-9666-88102-CD1912	PROGRAM INCOME EXPENSE	0.00	16,657.91	0.00	0.00	0.00	0.00	0.00
273-9666-88102-CD2015	PROGRAM INCOME EXPENSE	0.00	62,645.34	0.00	0.00	0.00	0.00	0.00
273-9666-88102-CD2213	PROGRAM INCOME EXPENSE	5,216.51	24,783.49	5,473.25	0.00	0.00	5,473.25	0.00
273-9666-88102-CD2313	PROGRAM INCOME EXPENSE	0.00	0.00	30,000.00	0.00	0.00	30,000.00	0.00
273-9666-90000	PRINTING & PUBLISHING	0.00	0.00	0.00	1,102.00	0.00	(1,102.00)	100.00
273-9666-90000-CD2213	PRINTING & PUBLISHING	2,490.85	0.00	0.00	0.00	0.00	0.00	0.00
273-9666-91000-CD1713	INSURANCE & BONDS	0.00	500.00	0.00	0.00	0.00	0.00	0.00
273-9666-91000-CD1812	INSURANCE & BONDS	0.00	388.88	0.00	0.00	0.00	0.00	0.00
273-9666-91000-CD1912	INSURANCE & BONDS	0.00	500.00	0.00	0.00	0.00	0.00	0.00
273-9666-91000-CD2015	INSURANCE & BONDS	0.00	500.00	0.00	0.00	0.00	0.00	0.00
273-9666-91000-CD2115	INSURANCE & BONDS	0.00	500.00	0.00	0.00	0.00	0.00	0.00
273-9666-91000-CD2213	INSURANCE & BONDS	0.00	500.00	0.00	0.00	0.00	0.00	0.00
273-9666-95000	ADMINISTRATIVE COSTS	0.00	208,624.00	0.00	2,571.23	100.00	(2,671.23)	100.00
273-9666-95000-CD2015	ADMINISTRATIVE COSTS	0.00	0.00	350.00	0.00	0.00	350.00	0.00
273-9666-95000-CD2115	ADMINISTRATIVE COSTS	0.00	0.00	135,057.29	135,793.29	543.50	(1,279.50)	100.95
273-9666-95000-CD2213	ADMINISTRATIVE COSTS	0.00	0.00	110,376.65	161,442.43	2,822.55	(53,888.33)	148.82
273-9666-95000-CD2313	ADMINISTRATIVE COSTS	0.00	0.00	208,624.00	400.00	0.00	208,224.00	0.19
273-9666-95000-CV2020	ADMINISTRATIVE COSTS	89,114.07	0.00	53,566.19	5,033.89	7.42	48,524.88	9.41
273-9666-98000-CV2020	OFFICE EQUIPMENT	7,084.00	0.00	0.00	0.00	0.00	0.00	0.00
Net - Dept 9666 - ADMINISTRATIVE COSTS		(306,737.19)	(1,499,826.03)	(543,947.38)	(306,342.84)	(3,473.47)	(234,131.07)	

Dept 9706 - RESID REHAB DELIVERY

273-9706-70600-CD1702	PERMANENT EMPLOYEES	0.00	9,539.70	0.00	0.00	0.00	0.00	0.00
273-9706-70600-CD1902	PERMANENT EMPLOYEES	0.00	21,062.49	0.00	0.00	0.00	0.00	0.00
273-9706-70600-CD2003	PERMANENT EMPLOYEES	0.00	24,664.20	0.00	0.00	0.00	0.00	0.00
273-9706-70600-CD2103	PERMANENT EMPLOYEES	370.53	39,629.47	0.00	0.00	0.00	0.00	0.00
273-9706-70600-CD2202	PERMANENT EMPLOYEES	0.00	7,150.00	0.00	0.00	0.00	0.00	0.00
273-9706-70609-CD1602	INSPECTORS	0.00	30,000.00	0.00	0.00	0.00	0.00	0.00
273-9706-70609-CD1702	INSPECTORS	0.00	60,565.47	0.00	0.00	0.00	0.00	0.00
273-9706-70609-CD1802	INSPECTORS	0.00	52,712.28	0.00	0.00	0.00	0.00	0.00
273-9706-70609-CD1902	INSPECTORS	0.00	84,026.26	0.00	0.00	0.00	0.00	0.00
273-9706-70609-CD2003	INSPECTORS	293.61	39,014.34	0.00	0.00	0.00	0.00	0.00
273-9706-70609-CD2103	INSPECTORS	11,712.71	45,300.03	0.00	0.00	0.00	0.00	0.00
273-9706-70609-CD2202	INSPECTORS	74,116.12	0.00	0.00	0.00	0.00	0.00	0.00
273-9706-70705-CD1802	TEMPORARY - INSPECTION	0.00	10,000.00	0.00	0.00	0.00	0.00	0.00
273-9706-70705-CD1902	TEMPORARY - INSPECTION	0.00	11,000.00	0.00	0.00	0.00	0.00	0.00

REVENUE AND EXPENDITURE REPORT

PERIOD ENDING 04/30/2024

% Fiscal Year Completed: 83.33

GL NUMBER	DESCRIPTION	END BALANCE	2023-24		YTD BALANCE	ENCUMBERED	UNENCUMBERED	% BGD
		06/30/2023	ORIGINAL	2023-24	04/30/2024			
		NORM (ABNORM)	BUDGET	AMENDED BUDGET	NORM (ABNORM)	YEAR-TO-DATE	BALANCE	USED
Fund 273 - CDBG ENTITLEMENT FUND								
273-9706-70705-CD2003	TEMPORARY - INSPECTION	0.00	10,000.00	0.00	0.00	0.00	0.00	0.00
273-9706-70705-CD2103	TEMPORARY - INSPECTION	0.00	3,300.00	0.00	0.00	0.00	0.00	0.00
273-9706-70712-CD1702	TEMPORARY - PLANNING AIDE	0.00	8,043.84	0.00	0.00	0.00	0.00	0.00
273-9706-70712-CD1802	TEMPORARY - PLANNING AIDE	0.00	9,000.00	0.00	0.00	0.00	0.00	0.00
273-9706-70712-CD1902	TEMPORARY - PLANNING AIDE	0.00	1,000.00	0.00	0.00	0.00	0.00	0.00
273-9706-70712-CD2003	TEMPORARY - PLANNING AIDE	0.00	8,092.50	0.00	0.00	0.00	0.00	0.00
273-9706-70712-CD2103	TEMPORARY - PLANNING AIDE	1,066.50	7,933.50	0.00	0.00	0.00	0.00	0.00
273-9706-70712-CD2202	TEMPORARY - PLANNING AIDE	0.00	3,500.00	0.00	0.00	0.00	0.00	0.00
273-9706-71302-CD2202	EDUCATION ALLOWANCE	400.00	100.00	0.00	0.00	0.00	0.00	0.00
273-9706-71303-CD2202	CLEAN/CLOTHING ALLOWANCE	350.00	0.00	0.00	0.00	0.00	0.00	0.00
273-9706-71500-CD1702	SOCIAL SECURITY	0.00	6,057.25	0.00	0.00	0.00	0.00	0.00
273-9706-71500-CD1802	SOCIAL SECURITY	0.00	7,404.53	0.00	0.00	0.00	0.00	0.00
273-9706-71500-CD1902	SOCIAL SECURITY	0.00	10,872.08	0.00	0.00	0.00	0.00	0.00
273-9706-71500-CD2003	SOCIAL SECURITY	22.01	7,951.15	0.00	0.00	0.00	0.00	0.00
273-9706-71500-CD2103	SOCIAL SECURITY	1,040.39	7,459.60	0.00	0.00	0.00	0.00	0.00
273-9706-71500-CD2202	SOCIAL SECURITY	5,620.00	0.00	0.00	0.00	0.00	0.00	0.00
273-9706-71900-CD2202	EMPLOYEE INSURANCES	31,955.01	0.00	0.00	0.00	0.00	0.00	0.00
273-9706-71905-CD1702	H.S.A. EXPENSE	0.00	689.37	0.00	0.00	0.00	0.00	0.00
273-9706-71905-CD1802	H.S.A. EXPENSE	0.00	745.17	0.00	0.00	0.00	0.00	0.00
273-9706-71905-CD1902	H.S.A. EXPENSE	0.00	1,200.00	0.00	0.00	0.00	0.00	0.00
273-9706-71905-CD2003	H.S.A. EXPENSE	5.87	1,194.13	0.00	0.00	0.00	0.00	0.00
273-9706-71905-CD2103	H.S.A. EXPENSE	0.00	1,760.22	0.00	0.00	0.00	0.00	0.00
273-9706-71905-CD2202	H.S.A. EXPENSE	1,526.91	0.00	0.00	0.00	0.00	0.00	0.00
273-9706-71906-CD1702	SUPPL LIFE INSURANCE EXP	0.00	250.00	0.00	0.00	0.00	0.00	0.00
273-9706-71906-CD1802	SUPPL LIFE INSURANCE EXP	0.00	250.00	0.00	0.00	0.00	0.00	0.00
273-9706-71906-CD1902	SUPPL LIFE INSURANCE EXP	0.00	300.00	0.00	0.00	0.00	0.00	0.00
273-9706-71906-CD2003	SUPPL LIFE INSURANCE EXP	0.00	300.00	0.00	0.00	0.00	0.00	0.00
273-9706-71906-CD2103	SUPPL LIFE INSURANCE EXP	0.00	284.50	0.00	0.00	0.00	0.00	0.00
273-9706-71906-CD2202	SUPPL LIFE INSURANCE EXP	312.00	501.00	0.00	0.00	0.00	0.00	0.00
273-9706-72201-CD1702	DEFINED CONTRIBUTION EXP	0.00	7,395.44	0.00	0.00	0.00	0.00	0.00
273-9706-72201-CD1802	DEFINED CONTRIBUTION EXP	0.00	11,763.07	0.00	0.00	0.00	0.00	0.00
273-9706-72201-CD1902	DEFINED CONTRIBUTION EXP	0.00	16,702.39	0.00	0.00	0.00	0.00	0.00
273-9706-72201-CD2003	DEFINED CONTRIBUTION EXP	29.36	13,134.43	0.00	0.00	0.00	0.00	0.00
273-9706-72201-CD2103	DEFINED CONTRIBUTION EXP	2,056.05	10,314.21	0.00	0.00	0.00	0.00	0.00
273-9706-72201-CD2202	DEFINED CONTRIBUTION EXP	7,634.79	650.27	0.00	0.00	0.00	0.00	0.00
273-9706-80100-CD1702	CONTRACTUAL SERVICES	0.00	2,500.00	0.00	0.00	0.00	0.00	0.00
273-9706-80100-CD1802	CONTRACTUAL SERVICES	0.00	2,500.00	0.00	0.00	0.00	0.00	0.00
273-9706-80100-CD1902	CONTRACTUAL SERVICES	0.00	2,500.00	0.00	0.00	0.00	0.00	0.00
273-9706-80100-CD2003	CONTRACTUAL SERVICES	0.00	2,500.00	0.00	0.00	0.00	0.00	0.00
273-9706-80100-CD2103	CONTRACTUAL SERVICES	0.00	3,500.00	0.00	0.00	0.00	0.00	0.00
273-9706-80100-CD2202	CONTRACTUAL SERVICES	0.00	3,500.00	0.00	0.00	0.00	0.00	0.00
273-9706-80134	DELIVERY COSTS	0.00	110,000.00	0.00	11,112.24	0.00	(11,112.24)	100.00
273-9706-80134-CD1702	DELIVERY COSTS	0.00	12,240.68	0.00	0.00	0.00	0.00	0.00
273-9706-80134-CD1802	DELIVERY COSTS	0.00	10,086.25	0.00	0.00	0.00	0.00	0.00
273-9706-80134-CD1902	DELIVERY COSTS	0.00	12,136.46	0.00	0.00	0.00	0.00	0.00
273-9706-80134-CD2003	DELIVERY COSTS	210.00	9,522.33	7,495.81	(350.85)	0.00	7,846.66	(4.68)
273-9706-80134-CD2103	DELIVERY COSTS	5,795.00	4,716.35	131,543.94	103,699.47	8,100.00	19,744.47	84.99
273-9706-80134-CD2202	DELIVERY COSTS	769.02	4,230.98	0.00	0.00	0.00	0.00	0.00
273-9706-80134-CD2302	DELIVERY COSTS	0.00	0.00	110,000.00	0.00	0.00	110,000.00	0.00
273-9706-80179-CD1702	RISK ASSESSMENT/PAINT INS	0.00	13,345.25	0.00	0.00	0.00	0.00	0.00
273-9706-80179-CD1802	RISK ASSESSMENT/PAINT INS	0.00	3,568.25	0.00	0.00	0.00	0.00	0.00
273-9706-80179-CD1902	RISK ASSESSMENT/PAINT INS	0.00	12,866.00	0.00	0.00	0.00	0.00	0.00
273-9706-80179-CD2003	RISK ASSESSMENT/PAINT INS	0.00	11,336.00	0.00	0.00	0.00	0.00	0.00
273-9706-80179-CD2103	RISK ASSESSMENT/PAINT INS	15,261.25	3,538.75	0.00	0.00	0.00	0.00	0.00
273-9706-80179-CD2202	RISK ASSESSMENT/PAINT INS	0.00	12,000.00	0.00	0.00	0.00	0.00	0.00
273-9706-86100-CD1702	MILEAGE	0.00	500.00	0.00	0.00	0.00	0.00	0.00
273-9706-86100-CD1802	MILEAGE	0.00	100.00	0.00	0.00	0.00	0.00	0.00

REVENUE AND EXPENDITURE REPORT

PERIOD ENDING 04/30/2024

% Fiscal Year Completed: 83.33

GL NUMBER	DESCRIPTION	END BALANCE	2023-24		YTD BALANCE	ENCUMBERED	UNENCUMBERED	% BDGT
		06/30/2023	ORIGINAL	2023-24	04/30/2024			
		NORM (ABNORM)	BUDGET	AMENDED BUDGET	NORM (ABNORM)	YEAR-TO-DATE	BALANCE	USED
Fund 273 - CDBG ENTITLEMENT FUND								
273-9706-86100-CD1902	MILEAGE	0.00	100.00	0.00	0.00	0.00	0.00	0.00
273-9706-86100-CD2003	MILEAGE	0.00	59.33	0.00	0.00	0.00	0.00	0.00
273-9706-86100-CD2103	MILEAGE	84.29	15.71	0.00	0.00	0.00	0.00	0.00
273-9706-86100-CD2202	MILEAGE	0.00	100.00	0.00	0.00	0.00	0.00	0.00
273-9706-86400-CD1702	CONFERENCES & WORKSHOPS	0.00	775.00	0.00	0.00	0.00	0.00	0.00
273-9706-86400-CD1802	CONFERENCES & WORKSHOPS	0.00	395.00	0.00	0.00	0.00	0.00	0.00
273-9706-86400-CD2003	CONFERENCES & WORKSHOPS	619.00	131.00	0.00	0.00	0.00	0.00	0.00
273-9706-86400-CD2103	CONFERENCES & WORKSHOPS	190.00	710.00	0.00	0.00	0.00	0.00	0.00
273-9706-86400-CD2202	CONFERENCES & WORKSHOPS	0.00	700.00	0.00	0.00	0.00	0.00	0.00
Net - Dept 9706 - RESID REHAB DELIVERY		(161,440.42)	(832,986.23)	(249,039.75)	(114,460.86)	(8,100.00)	(126,478.89)	
Dept 9707 - RESID REHAB PROJECTS								
273-9707-80118	REHAB PROJECT COSTS	0.00	139,500.00	0.00	0.00	0.00	0.00	0.00
273-9707-80118-CD1601	REHAB PROJECT COSTS	0.00	101,047.60	0.00	0.00	0.00	0.00	0.00
273-9707-80118-CD1801	REHAB PROJECT COSTS	0.00	42.57	0.00	0.00	0.00	0.00	0.00
273-9707-80118-CD2001	REHAB PROJECT COSTS	15,435.00	24,879.00	0.00	0.00	0.00	0.00	0.00
273-9707-80118-CD2101	REHAB PROJECT COSTS	14,923.93	9,942.07	0.00	0.00	0.00	0.00	0.00
273-9707-80118-CD2201	REHAB PROJECT COSTS	37,010.00	67,990.00	67,990.00	67,990.00	0.00	0.00	100.00
273-9707-80118-CD2301	REHAB PROJECT COSTS	0.00	0.00	139,500.00	139,500.00	0.00	0.00	100.00
273-9707-88102	PROGRAM INCOME EXPENSE	0.00	0.00	0.00	25,945.05	0.00	(25,945.05)	100.00
273-9707-88102-CD2101	PROGRAM INCOME EXPENSE	10,707.30	0.00	0.00	0.00	0.00	0.00	0.00
273-9707-88102-CD2201	PROGRAM INCOME EXPENSE	281,518.03	132,317.95	196,448.55	68,187.35	0.00	128,261.20	34.71
273-9707-88102-CD2301	PROGRAM INCOME EXPENSE	0.00	0.00	120,000.00	20,880.80	0.00	99,119.20	17.40
273-9707-88203-CD2002	LOCAL MATCH EXPENSE	9,678.80	18,706.20	18,706.20	10,824.50	0.00	7,881.70	57.87
273-9707-88203-CD2102	LOCAL MATCH EXPENSE	0.00	30,000.00	30,000.00	0.00	0.00	30,000.00	0.00
Net - Dept 9707 - RESID REHAB PROJECTS		(369,273.06)	(524,425.39)	(572,644.75)	(333,327.70)	0.00	(239,317.05)	
Dept 9757 - PARK IMPROVEMENTS								
273-9757-80100-CD2112	CONTRACTUAL SERVICES	0.00	200,000.00	200,000.00	0.00	0.00	200,000.00	0.00
273-9757-80100-CD2211	CONTRACTUAL SERVICES	1,300.00	343,342.34	343,342.34	175.00	343,167.34	0.00	100.00
Net - Dept 9757 - PARK IMPROVEMENTS		(1,300.00)	(543,342.34)	(543,342.34)	(175.00)	(343,167.34)	(200,000.00)	
Dept 9850 - UNALLOCATED EXPENSES								
273-9850-80117-CD2012	COOPERATIVE SERVICES	0.00	50.00	0.00	0.00	0.00	0.00	0.00
273-9850-80155	SHELTER FOR HOMELESS MITTEN MI	0.00	15,000.00	0.00	0.00	0.00	0.00	0.00
273-9850-80155-CD2309	SHELTER FOR HOMELESS MITTEN MI	0.00	0.00	15,000.00	15,000.00	0.00	0.00	100.00
273-9850-80156	CHORE SERVICES	0.00	40,000.00	0.00	0.00	0.00	0.00	0.00
273-9850-80156-CD2005	CHORE SERVICES	11,000.00	0.00	0.00	0.00	0.00	0.00	0.00
273-9850-80156-CD2105	CHORE SERVICES	40,000.00	0.00	0.00	0.00	0.00	0.00	0.00
273-9850-80156-CD2204	CHORE SERVICES	0.00	40,000.00	40,000.00	15,584.00	0.00	24,416.00	38.96
273-9850-80156-CD2304	CHORE SERVICES	0.00	0.00	40,000.00	1,456.00	0.00	38,544.00	3.64
273-9850-80157	SHELTER FOR THE HOMELESS	0.00	15,000.00	0.00	0.00	0.00	0.00	0.00
273-9850-80157-CD1909	SHELTER FOR THE HOMELESS	0.00	2,320.00	0.00	0.00	0.00	0.00	0.00
273-9850-80157-CD2007	SHELTER FOR THE HOMELESS	0.00	7,175.00	0.00	0.00	0.00	0.00	0.00
273-9850-80157-CD2010	SHELTER FOR THE HOMELESS	2,380.00	7,370.00	0.00	0.00	0.00	0.00	0.00
273-9850-80157-CD2110	SHELTER FOR THE HOMELESS	2,020.00	4,260.00	0.00	0.00	0.00	0.00	0.00
273-9850-80157-CD2206	SHELTER FOR THE HOMELESS	11,800.00	3,200.00	3,200.00	3,200.00	0.00	0.00	100.00
273-9850-80157-CD2207	SHELTER FOR THE HOMELESS	15,000.00	0.00	0.00	0.00	0.00	0.00	0.00
273-9850-80157-CD2209	SHELTER FOR THE HOMELESS	7,620.00	2,380.00	0.00	0.00	0.00	0.00	0.00
273-9850-80157-CD2307	SHELTER FOR THE HOMELESS	0.00	0.00	15,000.00	0.00	0.00	15,000.00	0.00
273-9850-80158	SHELTER FOR HOMELESS TURNING F	0.00	15,000.00	0.00	0.00	0.00	0.00	0.00

REVENUE AND EXPENDITURE REPORT

PERIOD ENDING 04/30/2024

% Fiscal Year Completed: 83.33

GL NUMBER	DESCRIPTION	END BALANCE	2023-24		YTD BALANCE	ENCUMBERED	UNENCUMBERED	% BDGT
		06/30/2023	ORIGINAL	2023-24	04/30/2024			
		NORM (ABNORM)	BUDGET	AMENDED BUDGET	NORM (ABNORM)	YEAR-TO-DATE	BALANCE	USED
Fund 273 - CDBG ENTITLEMENT FUND								
273-9850-80158-CD2306	SHELTER FOR HOMELESS TURNING F	0.00	0.00	15,000.00	15,000.00	0.00	0.00	100.00
273-9850-80159-CD1615	CONTINGENCIES	0.00	4,014.34	0.00	0.00	0.00	0.00	0.00
273-9850-80192	CODE ENFORCEMENT OFFICER	0.00	90,000.00	0.00	0.00	0.00	0.00	0.00
273-9850-80192-CD1603	CODE ENFORCEMENT OFFICER	80,000.00	0.00	0.00	0.00	0.00	0.00	0.00
273-9850-80192-CD2303	CODE ENFORCEMENT OFFICER	0.00	0.00	90,000.00	70,907.38	0.00	19,092.62	78.79
273-9850-80198	HOMELESS PREVENTION	0.00	30,000.00	0.00	0.00	0.00	0.00	0.00
273-9850-80198-CD1605	HOMELESS PREVENTION	0.00	2,352.09	0.00	0.00	0.00	0.00	0.00
273-9850-80198-CD2006	HOMELESS PREVENTION	0.00	20,371.72	0.00	0.00	0.00	0.00	0.00
273-9850-80198-CD2106	HOMELESS PREVENTION	2,274.90	0.00	0.00	0.00	0.00	0.00	0.00
273-9850-80198-CD2205	HOMELESS PREVENTION	24,060.00	940.00	0.00	0.00	0.00	0.00	0.00
273-9850-80198-CD2305	HOMELESS PREVENTION	0.00	0.00	30,000.00	13,316.22	0.00	16,683.78	44.39
273-9850-80198-CV2019	HOMELESS PREVENTION	436,748.12	0.00	0.00	0.00	0.00	0.00	0.00
273-9850-80199	HOMELESS PREVENTION - HEARTS F	0.00	10,000.00	0.00	0.00	0.00	0.00	0.00
273-9850-80199-CD2310	HOMELESS PREVENTION - HEARTS F	0.00	0.00	10,000.00	4,060.00	0.00	5,940.00	40.60
273-9850-80232	CHILD ADVOCACY	0.00	40,000.00	0.00	0.00	0.00	0.00	0.00
273-9850-80232-CD1608	CHILD ADVOCACY	21,047.60	0.00	0.00	0.00	0.00	0.00	0.00
273-9850-80232-CD2208	CHILD ADVOCACY	16,152.40	2,800.00	2,800.00	2,800.00	0.00	0.00	100.00
273-9850-80232-CD2308	CHILD ADVOCACY	0.00	0.00	40,000.00	40,000.00	0.00	0.00	100.00
Net - Dept 9850 - UNALLOCATED EXPENSES		(670,103.02)	(352,233.15)	(301,000.00)	(181,323.60)	0.00	(119,676.40)	
TOTAL REVENUES		2,005,367.26	1,418,244.25	(230,833.20)	826,190.26	0.00	(1,057,023.46)	357.92
TOTAL EXPENDITURES		1,853,711.95	4,191,047.67	2,541,970.22	935,630.00	356,440.81	1,249,899.41	50.83
NET OF REVENUES & EXPENDITURES		151,655.31	(2,772,803.42)	(2,772,803.42)	(109,439.74)	(356,440.81)	(2,306,922.87)	16.80
Fund 276 - HOME ARP								
Dept 0080 - REVENUES								
276-0080-53100	DRAWDOWN	0.00	0.00	2,048,247.00	0.00	0.00	2,048,247.00	0.00
Net - Dept 0080 - REVENUES		0.00	0.00	2,048,247.00	0.00	0.00	2,048,247.00	
Dept 9476 - ACQUISITION NEW CONSTRUCT								
276-9476-80197-HA2102	ENTITLEMENT	0.00	0.00	1,000,000.00	0.00	0.00	1,000,000.00	0.00
Net - Dept 9476 - ACQUISITION NEW CONSTRUCT		0.00	0.00	(1,000,000.00)	0.00	0.00	(1,000,000.00)	
Dept 9777 - PROGRAM ADMINISTRATION								
276-9777-95000-HA2103	ADMINISTRATIVE COSTS	0.00	0.00	307,237.00	0.00	0.00	307,237.00	0.00
Net - Dept 9777 - PROGRAM ADMINISTRATION		0.00	0.00	(307,237.00)	0.00	0.00	(307,237.00)	
Dept 9850 - UNALLOCATED EXPENSES								
276-9850-80198-HA2101	HOMELESS PREVENTION	0.00	0.00	741,010.00	0.00	0.00	741,010.00	0.00
Net - Dept 9850 - UNALLOCATED EXPENSES		0.00	0.00	(741,010.00)	0.00	0.00	(741,010.00)	
TOTAL REVENUES		0.00	0.00	2,048,247.00	0.00	0.00	2,048,247.00	0.00

REVENUE AND EXPENDITURE REPORT

PERIOD ENDING 04/30/2024

% Fiscal Year Completed: 83.33

GL NUMBER	DESCRIPTION	END BALANCE	2023-24		YTD BALANCE	ENCUMBERED	UNENCUMBERED	% BDGT
		06/30/2023	ORIGINAL	2023-24	04/30/2024			
		NORM (ABNORM)	BUDGET	AMENDED BUDGET	NORM (ABNORM)	YEAR-TO-DATE	BALANCE	USED
Fund 276 - HOME ARP								
TOTAL EXPENDITURES		0.00	0.00	2,048,247.00	0.00	0.00	2,048,247.00	0.00
NET OF REVENUES & EXPENDITURES		0.00	0.00	0.00	0.00	0.00	0.00	0.00
Fund 277 - H.O.M.E.								
Dept 0080 - REVENUES								
277-0080-53100	DRAWDOWN	0.00	543,764.00	543,764.00	87,289.75	0.00	456,474.25	16.05
277-0080-53102	PROGRAM INCOME	222,652.02	714,600.32	714,600.32	285,289.53	0.00	429,310.79	39.92
277-0080-53206	IN KIND MATCH	28,095.50	0.00	0.00	0.00	0.00	0.00	0.00
277-0080-66500	INTEREST EARNED	8,135.96	0.00	0.00	3,279.33	0.00	(3,279.33)	100.00
Net - Dept 0080 - REVENUES		258,883.48	1,258,364.32	1,258,364.32	375,858.61	0.00	882,505.71	
Dept 9474 - CHDO HOUSING DEVELOPMENT								
277-9474-80149	CHDO RESERVE	0.00	81,565.00	0.00	0.00	0.00	0.00	0.00
277-9474-80149-HM2101	CHDO RESERVE	0.00	84,771.00	84,771.00	0.00	0.00	84,771.00	0.00
277-9474-80149-HM2201	CHDO RESERVE	0.00	100,000.00	100,000.00	0.00	0.00	100,000.00	0.00
277-9474-80149-HM2301	CHDO RESERVE	0.00	0.00	81,565.00	0.00	0.00	81,565.00	0.00
277-9474-88102-HM1901	PROGRAM INCOME EXPENSE	0.00	24,831.00	24,831.00	0.00	0.00	24,831.00	0.00
Net - Dept 9474 - CHDO HOUSING DEVELOPMENT		0.00	(291,167.00)	(291,167.00)	0.00	0.00	(291,167.00)	
Dept 9476 - ACQUISITION NEW CONSTRUCT								
277-9476-80197	ENTITLEMENT	0.00	257,823.00	0.00	0.00	0.00	0.00	0.00
277-9476-80197-HM1803	ENTITLEMENT	0.00	13,037.00	13,037.00	0.00	0.00	13,037.00	0.00
277-9476-80197-HM1902	ENTITLEMENT	0.00	342,346.00	342,346.00	0.00	0.00	342,346.00	0.00
277-9476-80197-HM2003	ENTITLEMENT	0.00	377,875.00	377,875.00	0.00	0.00	377,875.00	0.00
277-9476-80197-HM2103	ENTITLEMENT	0.00	413,851.00	413,851.00	0.00	0.00	413,851.00	0.00
277-9476-80197-HM2203	ENTITLEMENT	0.00	367,375.00	367,375.00	0.00	0.00	367,375.00	0.00
277-9476-80197-HM2303	ENTITLEMENT	0.00	0.00	257,823.00	0.00	0.00	257,823.00	0.00
277-9476-88102	PROGRAM INCOME EXPENSE	0.00	137,697.00	0.00	0.00	0.00	0.00	0.00
277-9476-88102-HM2103	PROGRAM INCOME EXPENSE	187,441.90	80,538.00	80,538.00	40,125.50	0.00	40,412.50	49.82
277-9476-88102-HM2303	PROGRAM INCOME EXPENSE	0.00	0.00	137,697.00	0.00	0.00	137,697.00	0.00
277-9476-88203	LOCAL MATCH EXPENSE	38,436.29	0.00	0.00	7,402.75	0.00	(7,402.75)	100.00
277-9476-88204-HM2203	IN KIND MATCH EXPENSE	0.00	25,000.00	25,000.00	0.00	0.00	25,000.00	0.00
Net - Dept 9476 - ACQUISITION NEW CONSTRUCT		(225,878.19)	(2,015,542.00)	(2,015,542.00)	(47,528.25)	0.00	(1,968,013.75)	
Dept 9674 - ACQUISITION REHAB OTHER								
277-9674-88102	PROGRAM INCOME EXPENSE	0.00	0.00	0.00	19,788.73	0.00	(19,788.73)	100.00
Net - Dept 9674 - ACQUISITION REHAB OTHER		0.00	0.00	0.00	(19,788.73)	0.00	19,788.73	
Dept 9707 - RESID REHAB PROJECTS								
277-9707-80118	REHAB PROJECT COSTS	0.00	150,000.00	0.00	0.00	0.00	0.00	0.00
277-9707-80118-HM1602	REHAB PROJECT COSTS	0.00	147,758.40	147,758.40	87,289.75	0.00	60,468.65	59.08
277-9707-80118-HM1702	REHAB PROJECT COSTS	0.00	34,416.00	34,416.00	0.00	0.00	34,416.00	0.00
277-9707-80118-HM1802	REHAB PROJECT COSTS	0.00	23,639.00	23,639.00	0.00	0.00	23,639.00	0.00
277-9707-80118-HM2002	REHAB PROJECT COSTS	0.00	5,000.00	5,000.00	0.00	0.00	5,000.00	0.00
277-9707-80118-HM2102	REHAB PROJECT COSTS	0.00	10,000.00	10,000.00	0.00	0.00	10,000.00	0.00
277-9707-80118-HM2302	REHAB PROJECT COSTS	0.00	0.00	150,000.00	0.00	0.00	150,000.00	0.00
277-9707-88102	PROGRAM INCOME EXPENSE	0.00	75,000.00	0.00	0.00	0.00	0.00	0.00
277-9707-88102-HM2002	PROGRAM INCOME EXPENSE	62,811.41	5,050.09	5,050.09	0.00	0.00	5,050.09	0.00

REVENUE AND EXPENDITURE REPORT

PERIOD ENDING 04/30/2024

% Fiscal Year Completed: 83.33

GL NUMBER	DESCRIPTION	END BALANCE	2023-24		YTD BALANCE	ENCUMBERED	UNENCUMBERED	% BDGT
		06/30/2023	ORIGINAL	2023-24	04/30/2024			
		NORM (ABNORM)	BUDGET	AMENDED BUDGET	NORM (ABNORM)	YEAR-TO-DATE	BALANCE	USED
Fund 277 - H.O.M.E.								
277-9707-88102-HM2102	PROGRAM INCOME EXPENSE	214,232.11	126,605.25	126,605.25	(1,428.27)	0.00	128,033.52	(1.13)
277-9707-88102-HM2202	PROGRAM INCOME EXPENSE	29,785.00	0.00	0.00	75,000.00	0.00	(75,000.00)	100.00
277-9707-88102-HM2302	PROGRAM INCOME EXPENSE	0.00	0.00	75,000.00	0.00	0.00	75,000.00	0.00
Net - Dept 9707 - RESID REHAB PROJECTS		(306,828.52)	(577,468.74)	(577,468.74)	(160,861.48)	0.00	(416,607.26)	
Dept 9777 - PROGRAM ADMINISTRATION								
277-9777-70600-HM2105	PERMANENT EMPLOYEES	0.00	35,842.00	35,842.00	0.00	0.00	35,842.00	0.00
277-9777-70600-HM2204	PERMANENT EMPLOYEES	0.00	35,842.00	35,842.00	0.00	0.00	35,842.00	0.00
277-9777-70712-HM2105	TEMPORARY - PLANNING AIDE	0.00	2,000.00	2,000.00	0.00	0.00	2,000.00	0.00
277-9777-70712-HM2204	TEMPORARY - PLANNING AIDE	0.00	3,560.00	3,560.00	0.00	0.00	3,560.00	0.00
277-9777-71500-HM2105	SOCIAL SECURITY	0.00	2,000.00	2,000.00	0.00	0.00	2,000.00	0.00
277-9777-71500-HM2204	SOCIAL SECURITY	0.00	2,000.00	2,000.00	0.00	0.00	2,000.00	0.00
277-9777-71900-HM2105	EMPLOYEE INSURANCES	0.00	4,500.00	4,500.00	0.00	0.00	4,500.00	0.00
277-9777-71900-HM2204	EMPLOYEE INSURANCES	0.00	4,500.00	4,500.00	0.00	0.00	4,500.00	0.00
277-9777-71904-HM2105	RETIREE HEALTH INSURANCE	0.00	2,000.00	2,000.00	0.00	0.00	2,000.00	0.00
277-9777-71904-HM2204	RETIREE HEALTH INSURANCE	0.00	3,000.00	3,000.00	0.00	0.00	3,000.00	0.00
277-9777-72201-HM2105	DEFINED CONTRIBUTION EXP	0.00	3,472.00	3,472.00	0.00	0.00	3,472.00	0.00
277-9777-72201-HM2204	DEFINED CONTRIBUTION EXP	0.00	3,472.00	3,472.00	0.00	0.00	3,472.00	0.00
277-9777-72700-HM2105	OFFICE SUPPLIES	0.00	500.00	500.00	0.00	0.00	500.00	0.00
277-9777-72700-HM2204	OFFICE SUPPLIES	0.00	500.00	500.00	0.00	0.00	500.00	0.00
277-9777-80105-HM2105	INDEPENDENT AUDIT	0.00	5,000.00	5,000.00	0.00	0.00	5,000.00	0.00
277-9777-80105-HM2204	INDEPENDENT AUDIT	0.00	5,000.00	5,000.00	0.00	0.00	5,000.00	0.00
277-9777-86400-HM2105	CONFERENCES & WORKSHOPS	0.00	500.00	500.00	0.00	0.00	500.00	0.00
277-9777-86400-HM2204	CONFERENCES & WORKSHOPS	0.00	500.00	500.00	0.00	0.00	500.00	0.00
277-9777-88102	PROGRAM INCOME EXPENSE	0.00	23,633.00	0.00	0.00	0.00	0.00	0.00
277-9777-88102-HM2105	PROGRAM INCOME EXPENSE	25,199.46	0.00	0.00	168.75	1,034.75	(1,203.50)	100.00
277-9777-88102-HM2204	PROGRAM INCOME EXPENSE	0.00	46,142.00	46,142.00	0.00	0.00	46,142.00	0.00
277-9777-88102-HM2304	PROGRAM INCOME EXPENSE	0.00	0.00	23,633.00	0.00	0.00	23,633.00	0.00
277-9777-90000-HM2105	PRINTING & PUBLISHING	197.00	236.00	236.00	0.00	0.00	236.00	0.00
277-9777-90000-HM2204	PRINTING & PUBLISHING	510.00	0.00	0.00	0.00	0.00	0.00	0.00
277-9777-95000	ADMINISTRATIVE COSTS	0.00	54,376.00	0.00	494.00	0.00	(494.00)	100.00
277-9777-95000-HM2304	ADMINISTRATIVE COSTS	0.00	0.00	54,376.00	0.00	0.00	54,376.00	0.00
Net - Dept 9777 - PROGRAM ADMINISTRATION		(25,906.46)	(238,575.00)	(238,575.00)	(662.75)	(1,034.75)	(236,877.50)	
TOTAL REVENUES								
		258,883.48	1,258,364.32	1,258,364.32	375,858.61	0.00	882,505.71	29.87
TOTAL EXPENDITURES								
		558,613.17	3,122,752.74	3,122,752.74	228,841.21	1,034.75	2,892,876.78	7.36
NET OF REVENUES & EXPENDITURES		(299,729.69)	(1,864,388.42)	(1,864,388.42)	147,017.40	(1,034.75)	(2,010,371.07)	7.83
Fund 278 - HOUSING OPPORTUNITIES								
Dept 0080 - REVENUES								
278-0080-53100	DRAWDOWN	766,948.78	1,379,229.00	1,379,229.00	711,928.82	0.00	667,300.18	51.62
278-0080-53102	PROGRAM INCOME	0.00	2,535.03	208,484.29	0.00	0.00	208,484.29	0.00
278-0080-53118	HUD CARES ACT FUNDING	39,742.18	0.00	0.00	0.00	0.00	0.00	0.00
Net - Dept 0080 - REVENUES		806,690.96	1,381,764.03	1,587,713.29	711,928.82	0.00	875,784.47	
Dept 9778 - HOUSING OPPORTUNITIES EXP								
278-9778-70600-WA2005	PERMANENT EMPLOYEES	4,133.76	0.00	0.00	0.00	0.00	0.00	0.00
278-9778-70600-WA2105	PERMANENT EMPLOYEES	3,854.88	11,600.12	0.00	0.00	0.00	0.00	0.00

REVENUE AND EXPENDITURE REPORT

PERIOD ENDING 04/30/2024

% Fiscal Year Completed: 83.33

GL NUMBER	DESCRIPTION	END BALANCE	2023-24		YTD BALANCE	ENCUMBERED	UNENCUMBERED	% BGD
		06/30/2023	ORIGINAL	2023-24	04/30/2024			
		NORM (ABNORM)	BUDGET	AMENDED BUDGET	NORM (ABNORM)	YEAR-TO-DATE	BALANCE	USED
Fund 278 - HOUSING OPPORTUNITIES								
278-9778-70600-WA2205	PERMANENT EMPLOYEES	0.00	21,000.00	0.00	0.00	0.00	0.00	0.00
278-9778-71500-WA2005	SOCIAL SECURITY	316.24	0.00	0.00	0.00	0.00	0.00	0.00
278-9778-71500-WA2105	SOCIAL SECURITY	315.92	934.08	0.00	0.00	0.00	0.00	0.00
278-9778-71500-WA2205	SOCIAL SECURITY	0.00	1,215.00	0.00	0.00	0.00	0.00	0.00
278-9778-71900-WA2005	EMPLOYEE INSURANCES	454.71	0.00	0.00	0.00	0.00	0.00	0.00
278-9778-71900-WA2105	EMPLOYEE INSURANCES	0.00	1,600.00	0.00	0.00	0.00	0.00	0.00
278-9778-71900-WA2205	EMPLOYEE INSURANCES	0.00	2,500.00	0.00	0.00	0.00	0.00	0.00
278-9778-71904-WA2005	RETIREE HEALTH INSURANCE	516.22	0.00	0.00	0.00	0.00	0.00	0.00
278-9778-71904-WA2105	RETIREE HEALTH INSURANCE	1,588.71	25.29	0.00	0.00	0.00	0.00	0.00
278-9778-71904-WA2205	RETIREE HEALTH INSURANCE	0.00	1,500.00	0.00	0.00	0.00	0.00	0.00
278-9778-72201-WA2005	DEFINED CONTRIBUTION EXP	620.06	0.00	0.00	0.00	0.00	0.00	0.00
278-9778-72201-WA2105	DEFINED CONTRIBUTION EXP	747.72	820.28	0.00	0.00	0.00	0.00	0.00
278-9778-72201-WA2205	DEFINED CONTRIBUTION EXP	0.00	2,000.00	0.00	0.00	0.00	0.00	0.00
278-9778-80100	CONTRACTUAL SERVICES HOUSING A	0.00	60,000.00	0.00	0.00	0.00	0.00	0.00
278-9778-80100-WA2303	CONTRACTUAL SERVICES HOUSING A	0.00	0.00	60,000.00	0.00	0.00	60,000.00	0.00
278-9778-80105-WA2105	INDEPENDENT AUDIT	0.00	6,100.00	0.00	0.00	0.00	0.00	0.00
278-9778-80105-WA2205	INDEPENDENT AUDIT	0.00	6,100.00	0.00	0.00	0.00	0.00	0.00
278-9778-80136	MASTER LEASING PROGRAM	0.00	60,000.00	0.00	0.00	0.00	0.00	0.00
278-9778-80136-WA2207	MASTER LEASING PROGRAM	0.00	50,000.00	50,000.00	0.00	0.00	50,000.00	0.00
278-9778-80136-WA2306	MASTER LEASING PROGRAM	0.00	0.00	60,000.00	0.00	0.00	60,000.00	0.00
278-9778-80138	SHORTTERM RENT MTG UTILITY	0.00	80,000.00	0.00	0.00	0.00	0.00	0.00
278-9778-80138-WA2001	SHORTTERM RENT MTG UTILITY	2,164.00	0.00	0.00	0.00	0.00	0.00	0.00
278-9778-80138-WA2101	SHORTTERM RENT MTG UTILITY	11,013.39	635.63	635.63	635.63	0.00	0.00	100.00
278-9778-80138-WA2201	SHORTTERM RENT MTG UTILITY	4,141.13	21,342.28	21,342.28	13,456.42	0.00	7,885.86	63.05
278-9778-80138-WA2301	SHORTTERM RENT MTG UTILITY	0.00	0.00	80,000.00	44,561.68	0.00	35,438.32	55.70
278-9778-80138-WACV01	SHORTTERM RENT MTG UTILITY	19,237.68	0.00	0.00	0.00	0.00	0.00	0.00
278-9778-80139	MOVE IN ASSISTANCE	0.00	60,000.00	0.00	0.00	0.00	0.00	0.00
278-9778-80139-WA2006	MOVE IN ASSISTANCE	18,341.78	0.00	0.00	0.00	0.00	0.00	0.00
278-9778-80139-WA2106	MOVE IN ASSISTANCE	12,449.23	15,870.50	12,906.60	12,906.60	0.00	0.00	100.00
278-9778-80139-WA2206	MOVE IN ASSISTANCE	1,210.49	0.00	0.00	0.00	0.00	0.00	0.00
278-9778-80139-WA2305	MOVE IN ASSISTANCE	0.00	0.00	60,000.00	16,901.44	0.00	43,098.56	28.17
278-9778-80139-WACV06	MOVE IN ASSISTANCE	3,864.00	0.00	0.00	0.00	0.00	0.00	0.00
278-9778-80235-WACV07	PROJECT SPONSOR ADMIN	2,806.64	0.00	0.00	0.00	0.00	0.00	0.00
278-9778-80236	HOUSING ADVOCACY ASSIST.	0.00	400,000.00	0.00	0.00	0.00	0.00	0.00
278-9778-80236-WA2002	HOUSING ADVOCACY ASSIST.	1,253.69	0.00	0.00	0.00	0.00	0.00	0.00
278-9778-80236-WA2102	HOUSING ADVOCACY ASSIST.	60,034.73	44,148.62	0.00	0.00	0.00	0.00	0.00
278-9778-80236-WA2202	HOUSING ADVOCACY ASSIST.	168,942.36	0.00	129,503.58	90,906.32	0.00	38,597.26	70.20
278-9778-80236-WA2302	HOUSING ADVOCACY ASSIST.	0.00	0.00	400,000.00	129,725.01	0.00	270,274.99	32.43
278-9778-80237	TENANT BASED RENTAL ASST.	(814.00)	677,853.00	0.00	0.00	0.00	0.00	0.00
278-9778-80237-WA2003	TENANT BASED RENTAL ASST.	93,072.62	0.00	0.00	0.00	0.00	0.00	0.00
278-9778-80237-WA2103	TENANT BASED RENTAL ASST.	242,950.89	302,631.55	425,370.58	398,097.50	0.00	27,273.08	93.59
278-9778-80237-WA2203	TENANT BASED RENTAL ASST.	0.00	666,792.25	666,792.25	0.00	0.00	666,792.25	0.00
278-9778-80237-WA2303	TENANT BASED RENTAL ASST.	0.00	0.00	677,853.00	0.00	0.00	677,853.00	0.00
278-9778-80238-WA2104	IN HOME NON-MEDICAL CARE	29,804.18	75,626.51	0.00	0.00	0.00	0.00	0.00
278-9778-80238-WA2204	IN HOME NON-MEDICAL CARE	71,922.39	0.00	78,980.71	19,084.71	0.00	59,896.00	24.16
278-9778-90000-WA2005	PRINTING & PUBLISHING	0.00	700.00	0.00	0.00	0.00	0.00	0.00
278-9778-90000-WA2205	PRINTING & PUBLISHING	1,088.00	1,488.81	0.00	0.00	0.00	0.00	0.00
278-9778-95000	ADMINISTRATIVE COSTS	0.00	41,376.00	0.00	0.00	0.00	0.00	0.00
278-9778-95000-WA2105	ADMINISTRATIVE COSTS	0.00	0.00	19,244.74	576.00	1,500.00	17,168.74	10.79
278-9778-95000-WA2205	ADMINISTRATIVE COSTS	0.00	0.00	35,803.81	0.00	0.00	35,803.81	0.00
278-9778-95000-WA2304	ADMINISTRATIVE COSTS	0.00	0.00	41,376.00	0.00	0.00	41,376.00	0.00
278-9778-95000-WACV05	ADMINISTRATIVE COSTS	2,026.81	0.00	0.00	0.00	0.00	0.00	0.00
Net - Dept 9778 - HOUSING OPPORTUNITIES EXP		(758,058.23)	(2,613,859.92)	(2,819,809.18)	(726,851.31)	(1,500.00)	(2,091,457.87)	

REVENUE AND EXPENDITURE REPORT

PERIOD ENDING 04/30/2024

% Fiscal Year Completed: 83.33

GL NUMBER	DESCRIPTION	END BALANCE	2023-24		YTD BALANCE	ENCUMBERED	UNENCUMBERED	% BDGT
		06/30/2023	ORIGINAL	2023-24	04/30/2024			
		NORM (ABNORM)	BUDGET	AMENDED BUDGET	NORM (ABNORM)	YEAR-TO-DATE	BALANCE	USED
Fund 278 - HOUSING OPPORTUNITIES								
TOTAL REVENUES		806,690.96	1,381,764.03	1,587,713.29	711,928.82	0.00	875,784.47	44.84
TOTAL EXPENDITURES		758,058.23	2,613,859.92	2,819,809.18	726,851.31	1,500.00	2,091,457.87	25.83
NET OF REVENUES & EXPENDITURES		48,632.73	(1,232,095.89)	(1,232,095.89)	(14,922.49)	(1,500.00)	(1,215,673.40)	1.33
Fund 279 - NSP - 1								
Dept 0080 - REVENUES								
279-0080-53102	PROGRAM INCOME	15,029.75	0.00	0.00	14,213.97	0.00	(14,213.97)	100.00
Net - Dept 0080 - REVENUES		15,029.75	0.00	0.00	14,213.97	0.00	(14,213.97)	
TOTAL REVENUES		15,029.75	0.00	0.00	14,213.97	0.00	(14,213.97)	100.00
TOTAL EXPENDITURES		0.00	0.00	0.00	0.00	0.00	0.00	0.00
NET OF REVENUES & EXPENDITURES		15,029.75	0.00	0.00	14,213.97	0.00	(14,213.97)	100.00
Fund 280 - NSP - 3								
Dept 0080 - REVENUES								
280-0080-53100	DRAWDOWN	15,075.13	0.00	0.00	0.00	0.00	0.00	0.00
280-0080-53102	PROGRAM INCOME	(1,551.67)	0.00	0.00	0.00	0.00	0.00	0.00
Net - Dept 0080 - REVENUES		13,523.46	0.00	0.00	0.00	0.00	0.00	
Dept 9476 - ACQUISITION NEW CONSTRUCT								
280-9476-80134	DELIVERY COSTS	39.33	0.00	0.00	0.00	0.00	0.00	0.00
Net - Dept 9476 - ACQUISITION NEW CONSTRUCT		(39.33)	0.00	0.00	0.00	0.00	0.00	
Dept 9674 - ACQUISITION REHAB OTHER								
280-9674-80134	DELIVERY COSTS	15,075.13	0.00	0.00	0.00	0.00	0.00	0.00
Net - Dept 9674 - ACQUISITION REHAB OTHER		(15,075.13)	0.00	0.00	0.00	0.00	0.00	
Dept 9779 - ADMINISTRATIVE COSTS								
280-9779-72201	DEFINED CONTRIBUTION EXP	(1,591.00)	0.00	0.00	0.00	0.00	0.00	0.00
280-9779-96273	TRANSFER TO FUND 273	188,499.03	0.00	0.00	0.00	0.00	0.00	0.00
Net - Dept 9779 - ADMINISTRATIVE COSTS		(186,908.03)	0.00	0.00	0.00	0.00	0.00	
TOTAL REVENUES		13,523.46	0.00	0.00	0.00	0.00	0.00	0.00
TOTAL EXPENDITURES		202,022.49	0.00	0.00	0.00	0.00	0.00	0.00
NET OF REVENUES & EXPENDITURES		(188,499.03)	0.00	0.00	0.00	0.00	0.00	0.00
Fund 281 - LEAD HAZARD CONTROL GRANT								
Dept 0080 - REVENUES								
281-0080-53101	HEALTHY HOMES SUPPLEMENTAL GRA	49,290.00	250,710.00	250,710.00	0.00	0.00	250,710.00	0.00
281-0080-53119	LEAD HAZARD CONTROL GRANT 2019	181,557.36	775,823.66	775,823.66	190,490.25	0.00	585,333.41	24.55

REVENUE AND EXPENDITURE REPORT

PERIOD ENDING 04/30/2024

% Fiscal Year Completed: 83.33

GL NUMBER	DESCRIPTION	END BALANCE	2023-24		YTD BALANCE	ENCUMBERED	UNENCUMBERED	% BDGT
		06/30/2023	ORIGINAL	2023-24	04/30/2024			
		NORM (ABNORM)	BUDGET	AMENDED BUDGET	NORM (ABNORM)	YEAR-TO-DATE	BALANCE	USED
Fund 281 - LEAD HAZARD CONTROL GRANT								
281-0080-53203	MATCH	15,419.50	106,235.83	106,235.83	5,224.50	0.00	101,011.33	4.92
281-0080-66500	INTEREST EARNED	27.38	0.00	0.00	76.72	0.00	(76.72)	100.00
Net - Dept 0080 - REVENUES		246,294.24	1,132,769.49	1,132,769.49	195,791.47	0.00	936,978.02	
Dept 9666 - ADMINISTRATIVE COSTS								
281-9666-70600-LH1905	PERMANENT EMPLOYEES	20,729.75	4,578.98	4,578.98	0.00	0.00	4,578.98	0.00
281-9666-72501-LH1905	FEES & PER DIEM	2,251.96	5,054.24	5,054.24	1,690.00	0.00	3,364.24	33.44
281-9666-72502-LH1905	EMPLOYEE FRINGE BENEFITS	8,602.20	14,665.85	14,665.85	0.00	0.00	14,665.85	0.00
281-9666-72503-LH1905	TRANSPORTATION	3,505.60	2,641.35	2,641.35	0.00	0.00	2,641.35	0.00
281-9666-72700-LH1905	OFFICE SUPPLIES	193.00	1,033.15	1,033.15	0.00	0.00	1,033.15	0.00
281-9666-80105-LH1905	INDEPENDENT AUDIT	0.00	5,040.00	5,040.00	0.00	0.00	5,040.00	0.00
281-9666-98001-LH1905	COMPUTER EQUIPMENT	0.00	374.85	374.85	0.00	0.00	374.85	0.00
Net - Dept 9666 - ADMINISTRATIVE COSTS		(35,282.51)	(33,388.42)	(33,388.42)	(1,690.00)	0.00	(31,698.42)	
Dept 9706 - RESID REHAB DELIVERY								
281-9706-70600-LH1902	PERMANENT EMPLOYEES	19,739.81	233,448.93	233,448.93	0.00	0.00	233,448.93	0.00
281-9706-72502-LH1902	EMPLOYEE FRINGE BENEFITS	5,532.28	164,166.55	164,166.55	0.00	0.00	164,166.55	0.00
281-9706-80141-LH1903	TITLE SEARCH	1,185.00	1,195.00	1,195.00	1,000.00	195.00	0.00	100.00
281-9706-80177-LH1903	MOLD TESTING	0.00	6,000.00	6,000.00	0.00	0.00	6,000.00	0.00
281-9706-80178-LH1903	ASBESTOS SURVEY	0.00	14,000.00	14,000.00	0.00	0.00	14,000.00	0.00
281-9706-80179-LH1903	RISK ASSESSMENT/PAINT INS	16,711.00	20,195.50	20,195.50	16,050.00	7,500.00	(3,354.50)	116.61
281-9706-80201-LH1903	ENGINEERING & INSP SVCS	0.00	9,000.00	9,000.00	0.00	0.00	9,000.00	0.00
281-9706-80233-LH1903	RELOCATION COSTS	0.00	4,500.00	4,500.00	0.00	0.00	4,500.00	0.00
281-9706-86100-LH1903	MILEAGE	0.00	1,000.00	1,000.00	0.00	0.00	1,000.00	0.00
281-9706-88203-LH1902	LOCAL MATCH EXPENSE	7,014.61	15,757.63	15,757.63	0.00	0.00	15,757.63	0.00
Net - Dept 9706 - RESID REHAB DELIVERY		(50,182.70)	(469,263.61)	(469,263.61)	(17,050.00)	(7,695.00)	(444,518.61)	
Dept 9707 - RESID REHAB PROJECTS								
281-9707-80118-LH1901	REHAB PROJECT COSTS	87,106.20	300,358.80	300,358.80	103,150.50	0.00	197,208.30	34.34
281-9707-80228-LH1901	HEALTHY HOMES REHAB	49,290.00	220,710.00	220,710.00	38,929.00	0.00	181,781.00	17.64
281-9707-88203-LH1901	LOCAL MATCH EXPENSE	8,406.80	90,478.20	90,478.20	5,224.50	0.00	85,253.70	5.77
Net - Dept 9707 - RESID REHAB PROJECTS		(144,803.00)	(611,547.00)	(611,547.00)	(147,304.00)	0.00	(464,243.00)	
Dept 9850 - UNALLOCATED EXPENSES								
281-9850-80100-LH1904	CONTRACTUAL SERVICES	3,850.00	14,973.46	14,973.46	0.00	0.00	14,973.46	0.00
281-9850-82403-LH1904	EDUCATION	903.00	3,597.00	3,597.00	588.95	0.00	3,008.05	16.37
Net - Dept 9850 - UNALLOCATED EXPENSES		(4,753.00)	(18,570.46)	(18,570.46)	(588.95)	0.00	(17,981.51)	
TOTAL REVENUES		246,294.24	1,132,769.49	1,132,769.49	195,791.47	0.00	936,978.02	17.28
TOTAL EXPENDITURES		235,021.21	1,132,769.49	1,132,769.49	166,632.95	7,695.00	958,441.54	15.39
NET OF REVENUES & EXPENDITURES		11,273.03	0.00	0.00	29,158.52	(7,695.00)	(21,463.52)	100.00
Fund 356 - 2023 MTF DEBT RETIREMENT								
Dept 0080 - REVENUES								

REVENUE AND EXPENDITURE REPORT

PERIOD ENDING 04/30/2024

% Fiscal Year Completed: 83.33

GL NUMBER	DESCRIPTION	END BALANCE	2023-24		YTD BALANCE	ENCUMBERED	UNENCUMBERED	% BGD
		06/30/2023	ORIGINAL	2023-24	04/30/2024			
		NORM (ABNORM)	BUDGET	AMENDED BUDGET	NORM (ABNORM)	YEAR-TO-DATE	BALANCE	USED
Fund 356 - 2023 MTF DEBT RETIREMENT								
356-0080-69902	TRFR FROM MAJOR ST FUND	0.00	1,608,420.00	1,671,013.00	401,637.49	0.00	1,269,375.51	24.04
Net - Dept 0080 - REVENUES		0.00	1,608,420.00	1,671,013.00	401,637.49	0.00	1,269,375.51	
Dept 9356 - 2023 MTF DEBT EXPENDITURE								
356-9356-99102	BOND PRINCIPAL - MAJOR	0.00	560,000.00	745,000.00	0.00	0.00	745,000.00	0.00
356-9356-99502	BOND INTEREST MAJOR	0.00	1,047,920.00	925,513.00	401,637.49	0.00	523,875.51	43.40
356-9356-99802	AGENT FEES - MAJOR	0.00	500.00	500.00	0.00	0.00	500.00	0.00
Net - Dept 9356 - 2023 MTF DEBT EXPENDITURE		0.00	(1,608,420.00)	(1,671,013.00)	(401,637.49)	0.00	(1,269,375.51)	
TOTAL REVENUES		0.00	1,608,420.00	1,671,013.00	401,637.49	0.00	1,269,375.51	24.04
TOTAL EXPENDITURES		0.00	1,608,420.00	1,671,013.00	401,637.49	0.00	1,269,375.51	24.04
NET OF REVENUES & EXPENDITURES		0.00	0.00	0.00	0.00	0.00	0.00	0.00
Fund 357 - 2022 MTF DEBT RETIREMENT								
Dept 0080 - REVENUES								
357-0080-69902	TRFR FROM MAJOR ST FUND	922,054.17	923,750.00	923,750.00	279,625.00	0.00	644,125.00	30.27
Net - Dept 0080 - REVENUES		922,054.17	923,750.00	923,750.00	279,625.00	0.00	644,125.00	
Dept 9357 - 2022 MTF DEBT EXPENDITURE								
357-9357-99102	BOND PRINCIPAL - MAJOR	505,000.00	365,000.00	365,000.00	0.00	0.00	365,000.00	0.00
357-9357-99502	BOND INTEREST MAJOR	416,554.17	558,250.00	558,250.00	279,125.00	0.00	279,125.00	50.00
357-9357-99802	AGENT FEES - MAJOR	500.00	500.00	500.00	500.00	0.00	0.00	100.00
Net - Dept 9357 - 2022 MTF DEBT EXPENDITURE		(922,054.17)	(923,750.00)	(923,750.00)	(279,625.00)	0.00	(644,125.00)	
TOTAL REVENUES		922,054.17	923,750.00	923,750.00	279,625.00	0.00	644,125.00	30.27
TOTAL EXPENDITURES		922,054.17	923,750.00	923,750.00	279,625.00	0.00	644,125.00	30.27
NET OF REVENUES & EXPENDITURES		0.00	0.00	0.00	0.00	0.00	0.00	0.00
Fund 358 - 2013A REF 2006 CAP IMP								
Dept 0080 - REVENUES								
358-0080-69902	TRFR FROM MAJOR ST FUND	322,124.75	311,161.00	311,161.00	311,018.79	0.00	142.21	99.95
Net - Dept 0080 - REVENUES		322,124.75	311,161.00	311,161.00	311,018.79	0.00	142.21	
Dept 9358 - 2006 CAP IMP DEBT EXPEND								
358-9358-99102	BOND PRINCIPAL - MAJOR	305,305.98	298,123.00	298,123.00	298,122.31	0.00	0.69	100.00
358-9358-99502	BOND INTEREST MAJOR	16,459.59	12,538.00	12,538.00	12,537.30	0.00	0.70	99.99
358-9358-99802	AGENT FEES - MAJOR	359.18	500.00	500.00	359.18	0.00	140.82	71.84
Net - Dept 9358 - 2006 CAP IMP DEBT EXPEND		(322,124.75)	(311,161.00)	(311,161.00)	(311,018.79)	0.00	(142.21)	

REVENUE AND EXPENDITURE REPORT

PERIOD ENDING 04/30/2024

% Fiscal Year Completed: 83.33

GL NUMBER	DESCRIPTION	END BALANCE	2023-24		YTD BALANCE	ENCUMBERED	UNENCUMBERED	% BDGT
		06/30/2023	ORIGINAL	2023-24	04/30/2024			
		NORM (ABNORM)	BUDGET	AMENDED BUDGET	NORM (ABNORM)	YEAR-TO-DATE	BALANCE	USED
Fund 358 - 2013A REF 2006 CAP IMP								
TOTAL REVENUES		322,124.75	311,161.00	311,161.00	311,018.79	0.00	142.21	99.95
TOTAL EXPENDITURES		322,124.75	311,161.00	311,161.00	311,018.79	0.00	142.21	99.95
NET OF REVENUES & EXPENDITURES		0.00	0.00	0.00	0.00	0.00	0.00	0.00
Fund 359 - 2015 (2008) CAP IMP DEBT - ROADS								
Dept 0080 - REVENUES								
359-0080-69902	TRFR FROM MAJOR ST FUND	191,643.88	182,750.00	182,750.00	182,748.68	0.00	1.32	100.00
Net - Dept 0080 - REVENUES		191,643.88	182,750.00	182,750.00	182,748.68	0.00	1.32	
Dept 9359 - 2008 CAP IMP DEBT EXPENSE								
359-9359-99102	BOND PRINCIPAL - MAJOR	164,810.02	159,811.00	159,811.00	159,810.02	0.00	0.98	100.00
359-9359-99502	BOND INTEREST MAJOR	26,421.83	22,529.00	22,529.00	22,528.89	0.00	0.11	100.00
359-9359-99802	AGENT FEES - MAJOR	412.03	410.00	410.00	409.77	0.00	0.23	99.94
Net - Dept 9359 - 2008 CAP IMP DEBT EXPENSE		(191,643.88)	(182,750.00)	(182,750.00)	(182,748.68)	0.00	(1.32)	
TOTAL REVENUES		191,643.88	182,750.00	182,750.00	182,748.68	0.00	1.32	100.00
TOTAL EXPENDITURES		191,643.88	182,750.00	182,750.00	182,748.68	0.00	1.32	100.00
NET OF REVENUES & EXPENDITURES		0.00	0.00	0.00	0.00	0.00	0.00	0.00
Fund 360 - 2018 MTF DEBT								
Dept 0080 - REVENUES								
360-0080-69902	TRFR FROM MAJOR ST FUND	1,105,017.50	1,101,318.00	1,101,318.00	145,908.75	0.00	955,409.25	13.25
Net - Dept 0080 - REVENUES		1,105,017.50	1,101,318.00	1,101,318.00	145,908.75	0.00	955,409.25	
Dept 9360 - 2018 MTF DEBT								
360-9360-99102	BOND PRINCIPAL - MAJOR	790,000.00	810,000.00	810,000.00	0.00	0.00	810,000.00	0.00
360-9360-99502	BOND INTEREST MAJOR	314,517.50	290,818.00	290,818.00	145,408.75	0.00	145,409.25	50.00
360-9360-99802	AGENT FEES - MAJOR	500.00	500.00	500.00	500.00	0.00	0.00	100.00
Net - Dept 9360 - 2018 MTF DEBT		(1,105,017.50)	(1,101,318.00)	(1,101,318.00)	(145,908.75)	0.00	(955,409.25)	
TOTAL REVENUES		1,105,017.50	1,101,318.00	1,101,318.00	145,908.75	0.00	955,409.25	13.25
TOTAL EXPENDITURES		1,105,017.50	1,101,318.00	1,101,318.00	145,908.75	0.00	955,409.25	13.25
NET OF REVENUES & EXPENDITURES		0.00	0.00	0.00	0.00	0.00	0.00	0.00
Fund 361 - 2021 MTF DEBT								
Dept 0080 - REVENUES								
361-0080-69902	TRFR FROM MAJOR ST FUND	1,258,700.00	1,256,700.00	1,256,700.00	293,600.00	0.00	963,100.00	23.36
Net - Dept 0080 - REVENUES		1,258,700.00	1,256,700.00	1,256,700.00	293,600.00	0.00	963,100.00	

REVENUE AND EXPENDITURE REPORT

PERIOD ENDING 04/30/2024

% Fiscal Year Completed: 83.33

GL NUMBER	DESCRIPTION	END BALANCE	2023-24		YTD BALANCE	ENCUMBERED	UNENCUMBERED	% BDGT
		06/30/2023	ORIGINAL	2023-24	04/30/2024			
		NORM (ABNORM)	BUDGET	AMENDED BUDGET	NORM (ABNORM)	YEAR-TO-DATE	BALANCE	USED
Fund 361 - 2021 MTF DEBT								
Dept 9361 - 2021 MTF DEBT								
361-9361-99102	BOND PRINCIPAL - MAJOR	640,000.00	670,000.00	670,000.00	0.00	0.00	670,000.00	0.00
361-9361-99502	BOND INTEREST MAJOR	618,200.00	586,200.00	586,200.00	293,100.00	0.00	293,100.00	50.00
361-9361-99802	AGENT FEES - MAJOR	500.00	500.00	500.00	500.00	0.00	0.00	100.00
Net - Dept 9361 - 2021 MTF DEBT		(1,258,700.00)	(1,256,700.00)	(1,256,700.00)	(293,600.00)	0.00	(963,100.00)	
TOTAL REVENUES		1,258,700.00	1,256,700.00	1,256,700.00	293,600.00	0.00	963,100.00	23.36
TOTAL EXPENDITURES		1,258,700.00	1,256,700.00	1,256,700.00	293,600.00	0.00	963,100.00	23.36
NET OF REVENUES & EXPENDITURES		0.00	0.00	0.00	0.00	0.00	0.00	0.00
Fund 381 - 2008 CAP IMP DEBT - SDWLK								
Dept 0080 - REVENUES								
381-0080-69802	TRANS FROM S/A FUND 802	36,562.38	0.00	0.00	35,720.08	0.00	(35,720.08)	100.00
Net - Dept 0080 - REVENUES		36,562.38	0.00	0.00	35,720.08	0.00	(35,720.08)	
Dept 9381 - 2008 CAP IMP DEBT EXPENSE								
381-9381-99100	BOND PRINCIPAL PAID	35,189.98	0.00	0.00	35,189.98	0.00	(35,189.98)	100.00
381-9381-99500	BOND INTEREST PAID	1,284.43	0.00	0.00	439.87	0.00	(439.87)	100.00
381-9381-99800	AGENT FEES	87.97	0.00	0.00	90.23	0.00	(90.23)	100.00
Net - Dept 9381 - 2008 CAP IMP DEBT EXPENSE		(36,562.38)	0.00	0.00	(35,720.08)	0.00	35,720.08	
TOTAL REVENUES		36,562.38	0.00	0.00	35,720.08	0.00	(35,720.08)	100.00
TOTAL EXPENDITURES		36,562.38	0.00	0.00	35,720.08	0.00	(35,720.08)	100.00
NET OF REVENUES & EXPENDITURES		0.00	0.00	0.00	0.00	0.00	0.00	0.00
Fund 385 - CHAPTER 20/21 DRAIN DEBT								
Dept 0080 - REVENUES								
385-0080-40300	TAX COLLECTIONS	0.00	0.00	0.00	2.84	0.00	(2.84)	100.00
385-0080-66500	INTEREST ON INVESTMENTS	2,924.93	500.00	500.00	3,035.17	0.00	(2,535.17)	607.03
385-0080-69901	FUND BALANCE APPROPRIATED	0.00	25,000.00	25,000.00	0.00	0.00	25,000.00	0.00
Net - Dept 0080 - REVENUES		2,924.93	25,500.00	25,500.00	3,038.01	0.00	22,461.99	
Dept 9385 - CH 20/21 DRAIN DEBT EXPEN								
385-9385-99001	MAINTENANCE FEES	8,162.50	25,000.00	25,000.00	0.00	0.00	25,000.00	0.00
Net - Dept 9385 - CH 20/21 DRAIN DEBT EXPEN		(8,162.50)	(25,000.00)	(25,000.00)	0.00	0.00	(25,000.00)	
TOTAL REVENUES		2,924.93	25,500.00	25,500.00	3,038.01	0.00	22,461.99	11.91
TOTAL EXPENDITURES		8,162.50	25,000.00	25,000.00	0.00	0.00	25,000.00	0.00
NET OF REVENUES & EXPENDITURES		(5,237.57)	500.00	500.00	3,038.01	0.00	(2,538.01)	607.60

REVENUE AND EXPENDITURE REPORT

PERIOD ENDING 04/30/2024

% Fiscal Year Completed: 83.33

GL NUMBER	DESCRIPTION	END BALANCE	2023-24		YTD BALANCE	ENCUMBERED	UNENCUMBERED	% BDGT
		06/30/2023	ORIGINAL	2023-24	04/30/2024			
		NORM (ABNORM)	BUDGET	AMENDED BUDGET	NORM (ABNORM)	YEAR-TO-DATE	BALANCE	USED
Fund 386 - 2014 WCC REF DEBT 05								
Dept 0080 - REVENUES								
386-0080-69208	TRANSFER FROM P&R FUND	245,713.01	0.00	0.00	250,336.82	0.00	(250,336.82)	100.00
386-0080-69271	TRANSFER FROM LIBRARY	105,305.58	0.00	0.00	107,287.21	0.00	(107,287.21)	100.00
386-0080-69950	TRFR FROM CABLE TV FUND	351,018.62	0.00	0.00	357,624.06	0.00	(357,624.06)	100.00
Net - Dept 0080 - REVENUES		702,037.21	0.00	0.00	715,248.09	0.00	(715,248.09)	
Dept 9386 - B/A WCC REFUNDING EXPENSE								
386-9386-99100	BOND PRINCIPAL PAID	558,206.11	0.00	0.00	600,381.68	0.00	(600,381.68)	100.00
386-9386-99500	BOND INTEREST PAID	143,583.01	0.00	0.00	114,618.32	0.00	(114,618.32)	100.00
386-9386-99800	AGENT FEES	248.09	0.00	0.00	248.09	0.00	(248.09)	100.00
Net - Dept 9386 - B/A WCC REFUNDING EXPENSE		(702,037.21)	0.00	0.00	(715,248.09)	0.00	715,248.09	
TOTAL REVENUES								
		702,037.21	0.00	0.00	715,248.09	0.00	(715,248.09)	100.00
TOTAL EXPENDITURES								
		702,037.21	0.00	0.00	715,248.09	0.00	(715,248.09)	100.00
NET OF REVENUES & EXPENDITURES								
		0.00	0.00	0.00	0.00	0.00	0.00	0.00
Fund 391 - 2013 DDA REF 2002								
Dept 0080 - REVENUES								
391-0080-69494	TRANS FROM DDA	1,548,089.00	1,458,059.00	1,458,059.00	1,458,059.00	0.00	0.00	100.00
Net - Dept 0080 - REVENUES		1,548,089.00	1,458,059.00	1,458,059.00	1,458,059.00	0.00	0.00	
Dept 9391 - DDA SERIES 02 EXPENDITURE								
391-9391-99100	BOND PRINCIPAL PAID	1,515,000.00	1,435,000.00	1,435,000.00	1,435,000.00	0.00	0.00	100.00
391-9391-99500	BOND INTEREST PAID	32,589.00	22,559.00	22,559.00	22,559.00	0.00	0.00	100.00
391-9391-99800	AGENT FEES	500.00	500.00	500.00	500.00	0.00	0.00	100.00
Net - Dept 9391 - DDA SERIES 02 EXPENDITURE		(1,548,089.00)	(1,458,059.00)	(1,458,059.00)	(1,458,059.00)	0.00	0.00	
TOTAL REVENUES								
		1,548,089.00	1,458,059.00	1,458,059.00	1,458,059.00	0.00	0.00	100.00
TOTAL EXPENDITURES								
		1,548,089.00	1,458,059.00	1,458,059.00	1,458,059.00	0.00	0.00	100.00
NET OF REVENUES & EXPENDITURES								
		0.00	0.00	0.00	0.00	0.00	0.00	0.00
Fund 392 - 2023 DDA GEN OB DEBT								
Dept 0080 - REVENUES								
392-0080-69494	TRANS FROM DDA	0.00	1,659,959.00	1,659,959.00	558,958.32	0.00	1,101,000.68	33.67
Net - Dept 0080 - REVENUES		0.00	1,659,959.00	1,659,959.00	558,958.32	0.00	1,101,000.68	
Dept 9392 - DDA SERIES 2023 DEBT EXPENDITURE								
392-9392-99100	BOND PRINCIPAL PAID	0.00	585,000.00	585,000.00	0.00	0.00	585,000.00	0.00
392-9392-99500	BOND INTEREST PAID	0.00	1,073,959.00	1,073,959.00	558,458.32	0.00	515,500.68	52.00
392-9392-99800	AGENT FEES	0.00	1,000.00	1,000.00	500.00	0.00	500.00	50.00
Net - Dept 9392 - DDA SERIES 2023 DEBT EXPENDITURE		0.00	(1,659,959.00)	(1,659,959.00)	(558,958.32)	0.00	(1,101,000.68)	

REVENUE AND EXPENDITURE REPORT

PERIOD ENDING 04/30/2024

% Fiscal Year Completed: 83.33

GL NUMBER	DESCRIPTION	END BALANCE	2023-24		YTD BALANCE	ENCUMBERED	UNENCUMBERED	% BDGT
		06/30/2023	ORIGINAL	2023-24	04/30/2024			
		NORM (ABNORM)	BUDGET	AMENDED BUDGET	NORM (ABNORM)	YEAR-TO-DATE	BALANCE	USED
Fund 392 - 2023 DDA GEN OB DEBT								
TOTAL REVENUES		0.00	1,659,959.00	1,659,959.00	558,958.32	0.00	1,101,000.68	33.67
TOTAL EXPENDITURES		0.00	1,659,959.00	1,659,959.00	558,958.32	0.00	1,101,000.68	33.67
NET OF REVENUES & EXPENDITURES		0.00	0.00	0.00	0.00	0.00	0.00	0.00
Fund 393 - 2014 DDA REF 2003 & 2004								
Dept 0080 - REVENUES								
393-0080-69494	TRANS FROM DDA	3,342,600.00	3,220,525.00	3,220,525.00	3,220,525.00	0.00	0.00	100.00
Net - Dept 0080 - REVENUES		3,342,600.00	3,220,525.00	3,220,525.00	3,220,525.00	0.00	0.00	
Dept 9393 - DDA SERIES 04 DEBT EXPEND								
393-9393-99100	BOND PRINCIPAL PAID	2,920,000.00	2,885,000.00	2,885,000.00	2,885,000.00	0.00	0.00	100.00
393-9393-99500	BOND INTEREST PAID	422,100.00	335,025.00	335,025.00	335,025.00	0.00	0.00	100.00
393-9393-99800	AGENT FEES	500.00	500.00	500.00	500.00	0.00	0.00	100.00
Net - Dept 9393 - DDA SERIES 04 DEBT EXPEND		(3,342,600.00)	(3,220,525.00)	(3,220,525.00)	(3,220,525.00)	0.00	0.00	
TOTAL REVENUES		3,342,600.00	3,220,525.00	3,220,525.00	3,220,525.00	0.00	0.00	100.00
TOTAL EXPENDITURES		3,342,600.00	3,220,525.00	3,220,525.00	3,220,525.00	0.00	0.00	100.00
NET OF REVENUES & EXPENDITURES		0.00	0.00	0.00	0.00	0.00	0.00	0.00
Fund 394 - 2015 DDA REF 2005								
Dept 0080 - REVENUES								
394-0080-69494	TRANS FROM DDA	1,234,050.00	1,430,425.00	1,430,425.00	1,430,425.00	0.00	0.00	100.00
Net - Dept 0080 - REVENUES		1,234,050.00	1,430,425.00	1,430,425.00	1,430,425.00	0.00	0.00	
Dept 9394 - DDA SERIES 05 DEBT EXPEND								
394-9394-99100	BOND PRINCIPAL PAID	1,010,000.00	1,235,000.00	1,235,000.00	1,235,000.00	0.00	0.00	100.00
394-9394-99500	BOND INTEREST PAID	223,550.00	194,925.00	194,925.00	194,925.00	0.00	0.00	100.00
394-9394-99800	AGENT FEES	500.00	500.00	500.00	500.00	0.00	0.00	100.00
Net - Dept 9394 - DDA SERIES 05 DEBT EXPEND		(1,234,050.00)	(1,430,425.00)	(1,430,425.00)	(1,430,425.00)	0.00	0.00	
TOTAL REVENUES		1,234,050.00	1,430,425.00	1,430,425.00	1,430,425.00	0.00	0.00	100.00
TOTAL EXPENDITURES		1,234,050.00	1,430,425.00	1,430,425.00	1,430,425.00	0.00	0.00	100.00
NET OF REVENUES & EXPENDITURES		0.00	0.00	0.00	0.00	0.00	0.00	0.00
Fund 410 - 37TH D.C. BLDG RENOVATION								
Dept 0080 - REVENUES								
410-0080-65803	COURT BLDG RENOVATION FEE	546,292.37	500,000.00	500,000.00	365,494.74	0.00	134,505.26	73.10
410-0080-66500	INTEREST ON INVESTMENTS	400,269.46	15,000.00	15,000.00	438,230.41	0.00	(423,230.41)	2,921.54
410-0080-69901	FUND BALANCE APPROPRIATED	0.00	0.00	306,932.00	0.00	0.00	306,932.00	0.00
Net - Dept 0080 - REVENUES		946,561.83	515,000.00	821,932.00	803,725.15	0.00	18,206.85	

REVENUE AND EXPENDITURE REPORT

PERIOD ENDING 04/30/2024

% Fiscal Year Completed: 83.33

GL NUMBER	DESCRIPTION	END BALANCE	2023-24		YTD BALANCE	ENCUMBERED	UNENCUMBERED	% BDGT
		06/30/2023	ORIGINAL	2023-24	04/30/2024			
		NORM (ABNORM)	BUDGET	AMENDED BUDGET	NORM (ABNORM)	YEAR-TO-DATE	BALANCE	USED
Fund 410 - 37TH D.C. BLDG RENOVATION								
Dept 9410 - COURT BLDG RENOVATION EXP								
410-9410-97400	CAPITAL IMPROVEMENTS	240,334.48	500,000.00	806,932.00	226,025.54	263,011.64	317,894.82	60.60
Net - Dept 9410 - COURT BLDG RENOVATION EXP		(240,334.48)	(500,000.00)	(806,932.00)	(226,025.54)	(263,011.64)	(317,894.82)	
TOTAL REVENUES		946,561.83	515,000.00	821,932.00	803,725.15	0.00	18,206.85	97.78
TOTAL EXPENDITURES		240,334.48	500,000.00	806,932.00	226,025.54	263,011.64	317,894.82	60.60
NET OF REVENUES & EXPENDITURES		706,227.35	15,000.00	15,000.00	577,699.61	(263,011.64)	(299,687.97)	2,097.92
Fund 433 - 2018 MTF CONSTRUCTION								
Dept 0080 - REVENUES								
433-0080-66500	INTEREST ON INVESTMENTS	13,661.05	0.00	0.00	29,144.02	0.00	(29,144.02)	100.00
Net - Dept 0080 - REVENUES		13,661.05	0.00	0.00	29,144.02	0.00	(29,144.02)	
TOTAL REVENUES		13,661.05	0.00	0.00	29,144.02	0.00	(29,144.02)	100.00
TOTAL EXPENDITURES		0.00	0.00	0.00	0.00	0.00	0.00	0.00
NET OF REVENUES & EXPENDITURES		13,661.05	0.00	0.00	29,144.02	0.00	(29,144.02)	100.00
Fund 434 - 2021 MTF CONSTRUCTION								
Dept 0080 - REVENUES								
434-0080-66500	INTEREST ON INVESTMENTS	114,330.08	0.00	0.00	111,460.69	0.00	(111,460.69)	100.00
Net - Dept 0080 - REVENUES		114,330.08	0.00	0.00	111,460.69	0.00	(111,460.69)	
Dept 9434 - 2021 MTF CSTR EXPENDITURE								
434-9434-97450	CONSTRUCTION CONTRACTS	5,726,594.95	0.00	0.00	4,073,964.95	0.00	(4,073,964.95)	100.00
Net - Dept 9434 - 2021 MTF CSTR EXPENDITURE		(5,726,594.95)	0.00	0.00	(4,073,964.95)	0.00	4,073,964.95	
TOTAL REVENUES		114,330.08	0.00	0.00	111,460.69	0.00	(111,460.69)	100.00
TOTAL EXPENDITURES		5,726,594.95	0.00	0.00	4,073,964.95	0.00	(4,073,964.95)	100.00
NET OF REVENUES & EXPENDITURES		(5,612,264.87)	0.00	0.00	(3,962,504.26)	0.00	3,962,504.26	100.00
Fund 435 - 2006 CAPITAL IMPROV BONDS								
Dept 0080 - REVENUES								
435-0080-66500	INTEREST ON INVESTMENTS	101.76	0.00	0.00	0.00	0.00	0.00	0.00
Net - Dept 0080 - REVENUES		101.76	0.00	0.00	0.00	0.00	0.00	
Dept 9435 - 2006 CAPITAL IMPROV EXP.								
435-9435-96202	CONTRIB TO MAJOR STREETS	101.76	0.00	0.00	0.00	0.00	0.00	0.00
Net - Dept 9435 - 2006 CAPITAL IMPROV EXP.		(101.76)	0.00	0.00	0.00	0.00	0.00	

REVENUE AND EXPENDITURE REPORT

PERIOD ENDING 04/30/2024

% Fiscal Year Completed: 83.33

GL NUMBER	DESCRIPTION	END BALANCE	2023-24		YTD BALANCE	ENCUMBERED	UNENCUMBERED	% BDGT
		06/30/2023	ORIGINAL	2023-24	04/30/2024			
		NORM (ABNORM)	BUDGET	AMENDED BUDGET	NORM (ABNORM)	YEAR-TO-DATE	BALANCE	USED
Fund 435 - 2006 CAPITAL IMPROV BONDS								
TOTAL REVENUES		101.76	0.00	0.00	0.00	0.00	0.00	0.00
TOTAL EXPENDITURES		101.76	0.00	0.00	0.00	0.00	0.00	0.00
NET OF REVENUES & EXPENDITURES		0.00	0.00	0.00	0.00	0.00	0.00	0.00
Fund 436 - 2008 CAPITAL IMPROV BONDS								
Dept 0080 - REVENUES								
436-0080-66500	INTEREST ON INVESTMENTS	0.04	0.00	0.00	0.00	0.00	0.00	0.00
Net - Dept 0080 - REVENUES		0.04	0.00	0.00	0.00	0.00	0.00	0.00
Dept 9436 - 2008 CAPITAL IMP EXPENSE								
436-9436-96301	TRANS TO GENERAL FUND	0.04	0.00	0.00	0.00	0.00	0.00	0.00
Net - Dept 9436 - 2008 CAPITAL IMP EXPENSE		(0.04)	0.00	0.00	0.00	0.00	0.00	0.00
TOTAL REVENUES		0.04	0.00	0.00	0.00	0.00	0.00	0.00
TOTAL EXPENDITURES		0.04	0.00	0.00	0.00	0.00	0.00	0.00
NET OF REVENUES & EXPENDITURES		0.00	0.00	0.00	0.00	0.00	0.00	0.00
Fund 437 - 2022 MTF CONSTRUCTION								
Dept 0080 - REVENUES								
437-0080-66500	INTEREST ON INVESTMENTS	38,563.71	0.00	0.00	121,437.03	0.00	(121,437.03)	100.00
437-0080-69603	BOND PROCEEDS	13,309,214.65	0.00	0.00	0.00	0.00	0.00	0.00
Net - Dept 0080 - REVENUES		13,347,778.36	0.00	0.00	121,437.03	0.00	(121,437.03)	
Dept 9437 - 2022 MTF CONSTRUCTION								
437-9437-80129	BOND ISSUANCE COSTS	219,758.40	0.00	0.00	0.00	0.00	0.00	0.00
437-9437-97450	CONSTRUCTION CONTRACTS	6,793,390.20	0.00	0.00	3,486,987.59	0.00	(3,486,987.59)	100.00
Net - Dept 9437 - 2022 MTF CONSTRUCTION		(7,013,148.60)	0.00	0.00	(3,486,987.59)	0.00	3,486,987.59	
TOTAL REVENUES		13,347,778.36	0.00	0.00	121,437.03	0.00	(121,437.03)	100.00
TOTAL EXPENDITURES		7,013,148.60	0.00	0.00	3,486,987.59	0.00	(3,486,987.59)	100.00
NET OF REVENUES & EXPENDITURES		6,334,629.76	0.00	0.00	(3,365,550.56)	0.00	3,365,550.56	100.00
Fund 438 - 2023 MTF CONSTRUCTION								
Dept 0080 - REVENUES								
438-0080-66500	INTEREST ON INVESTMENTS	0.00	0.00	0.00	630,600.61	0.00	(630,600.61)	100.00
438-0080-69603	BOND PROCEEDS	0.00	0.00	0.00	23,534,655.35	0.00	(23,534,655.35)	100.00
Net - Dept 0080 - REVENUES		0.00	0.00	0.00	24,165,255.96	0.00	(24,165,255.96)	

REVENUE AND EXPENDITURE REPORT

PERIOD ENDING 04/30/2024

% Fiscal Year Completed: 83.33

GL NUMBER	DESCRIPTION	END BALANCE	2023-24		YTD BALANCE	ENCUMBERED	UNENCUMBERED	% BDGT
		06/30/2023	ORIGINAL	2023-24	04/30/2024			
		NORM (ABNORM)	BUDGET	AMENDED BUDGET	NORM (ABNORM)	YEAR-TO-DATE	BALANCE	USED
Fund 438 - 2023 MTF CONSTRUCTION								
Dept 9438 - 2023 MTF CONSTRUCTION								
438-9438-80129	BOND ISSUANCE COSTS	0.00	0.00	0.00	199,251.55	0.00	(199,251.55)	100.00
438-9438-97450	CONSTRUCTION CONTRACTS	384,909.78	0.00	0.00	3,823,043.18	0.00	(3,823,043.18)	100.00
Net - Dept 9438 - 2023 MTF CONSTRUCTION		(384,909.78)	0.00	0.00	(4,022,294.73)	0.00	4,022,294.73	
TOTAL REVENUES		0.00	0.00	0.00	24,165,255.96	0.00	(24,165,255.96)	100.00
TOTAL EXPENDITURES		384,909.78	0.00	0.00	4,022,294.73	0.00	(4,022,294.73)	100.00
NET OF REVENUES & EXPENDITURES		(384,909.78)	0.00	0.00	20,142,961.23	0.00	(20,142,961.23)	100.00
Fund 492 - BROWNFIELD AUTHORITY								
Dept 0080 - REVENUES								
492-0080-40601	TAXES - LIPARI WBCE PROPERTIES	424,179.30	0.00	0.00	0.00	0.00	0.00	0.00
492-0080-40602	TAXES - DKM HOLDINGS	104,157.47	0.00	0.00	0.00	0.00	0.00	0.00
492-0080-40603	TAXES - UNIVERSAL PROP.	265,395.28	0.00	0.00	0.00	0.00	0.00	0.00
492-0080-40604	TAXES - STAR WARREN	15,944.82	0.00	0.00	0.00	0.00	0.00	0.00
492-0080-40605	TAXES - MEIJER	416,057.63	0.00	0.00	0.00	0.00	0.00	0.00
492-0080-40606	TAXES-WARREN 10 MILE LLC	11,610.45	0.00	0.00	0.00	0.00	0.00	0.00
492-0080-40607	TAXES-LECOM/J.A.L.	93,814.46	0.00	0.00	0.00	0.00	0.00	0.00
492-0080-66500	INTEREST ON INVESTMENTS	8,289.59	0.00	0.00	9,262.70	0.00	(9,262.70)	100.00
492-0080-67900	MISCELLANEOUS REVENUE	80,669.98	0.00	0.00	750.00	0.00	(750.00)	100.00
Net - Dept 0080 - REVENUES		1,420,118.98	0.00	0.00	10,012.70	0.00	(10,012.70)	
Dept 9492 - BROWNFIELD EXPENDITURES								
492-9492-80100	CONTRACTUAL SERVICES	27,774.19	0.00	0.00	29,687.00	0.00	(29,687.00)	100.00
492-9492-80701	PROJECT COSTS - LIPARI WBCE PF	399,024.25	0.00	0.00	0.00	0.00	0.00	0.00
492-9492-80702	PROJECT COSTS - DKM	104,157.47	0.00	0.00	79,644.71	0.00	(79,644.71)	100.00
492-9492-80703	PROJECT COSTS - UNIVERSAL	265,395.27	0.00	0.00	0.00	0.00	0.00	0.00
492-9492-80704	PROJECT COSTS - STAR WARREN	15,482.96	0.00	0.00	0.00	0.00	0.00	0.00
492-9492-80705	PROJECT COSTS - MEIJER	403,615.22	0.00	0.00	0.00	0.00	0.00	0.00
492-9492-80706	PROJECT COSTS - WARREN 10 LLC	8,486.06	0.00	0.00	0.00	0.00	0.00	0.00
492-9492-80707	PROJECT COSTS LECOM/JAL	84,555.02	0.00	0.00	0.00	0.00	0.00	0.00
492-9492-80799	MISC CAPTURES DUE	50,443.15	0.00	0.00	0.00	0.00	0.00	0.00
Net - Dept 9492 - BROWNFIELD EXPENDITURES		(1,358,933.59)	0.00	0.00	(109,331.71)	0.00	109,331.71	
TOTAL REVENUES		1,420,118.98	0.00	0.00	10,012.70	0.00	(10,012.70)	100.00
TOTAL EXPENDITURES		1,358,933.59	0.00	0.00	109,331.71	0.00	(109,331.71)	100.00
NET OF REVENUES & EXPENDITURES		61,185.39	0.00	0.00	(99,319.01)	0.00	99,319.01	100.00
Fund 493 - DDA CONSTRUCTION FUND								
Dept 0080 - REVENUES								
493-0080-66500	INTEREST ON INVESTMENTS	127,040.95	0.00	0.00	952,833.81	0.00	(952,833.81)	100.00
493-0080-69603	BOND PROCEEDS	22,921,908.35	0.00	0.00	0.00	0.00	0.00	0.00
Net - Dept 0080 - REVENUES		23,048,949.30	0.00	0.00	952,833.81	0.00	(952,833.81)	

REVENUE AND EXPENDITURE REPORT

PERIOD ENDING 04/30/2024

% Fiscal Year Completed: 83.33

GL NUMBER	DESCRIPTION	END BALANCE	2023-24		YTD BALANCE	ENCUMBERED	UNENCUMBERED	% BDGT
		06/30/2023	ORIGINAL	2023-24	04/30/2024			
		NORM (ABNORM)	BUDGET	AMENDED BUDGET	NORM (ABNORM)	YEAR-TO-DATE	BALANCE	USED
Fund 493 - DDA CONSTRUCTION FUND								
Dept 9493 - DDA CONSTRUCTION EXPENSES								
493-9493-80100	CONTRACTUAL SERVICES	30.00	0.00	0.00	0.00	0.00	0.00	0.00
493-9493-80129	BOND ISSUANCE COSTS	222,405.36	0.00	0.00	0.00	0.00	0.00	0.00
493-9493-96494	TRANS TO DDA ADMIN FUND	260,975.36	0.00	0.00	0.00	0.00	0.00	0.00
493-9493-97450	CONSTRUCTION CONTRACTS	963,219.35	0.00	0.00	1,886,466.97	0.00	(1,886,466.97)	100.00
Net - Dept 9493 - DDA CONSTRUCTION EXPENSES		(1,446,630.07)	0.00	0.00	(1,886,466.97)	0.00	1,886,466.97	
TOTAL REVENUES		23,048,949.30	0.00	0.00	952,833.81	0.00	(952,833.81)	100.00
TOTAL EXPENDITURES		1,446,630.07	0.00	0.00	1,886,466.97	0.00	(1,886,466.97)	100.00
NET OF REVENUES & EXPENDITURES		21,602,319.23	0.00	0.00	(933,633.16)	0.00	933,633.16	100.00
Fund 494 - DDA ADMINISTRATION FUND								
Dept 0080 - REVENUES								
494-0080-40309	PROPERTY TAXES: DDA	7,296,426.51	7,313,000.00	7,313,000.00	6,094,160.00	0.00	1,218,840.00	83.33
494-0080-57300	LOCAL COMM STABILIZ SHARE	4,907,998.00	4,200,000.00	4,200,000.00	5,124,608.15	0.00	(924,608.15)	122.01
494-0080-66500	INTEREST ON INVESTMENTS	709,526.05	75,000.00	75,000.00	(381,951.34)	0.00	456,951.34	(509.27)
494-0080-67900	MISCELLANEOUS REVENUE	50.00	25,000.00	25,000.00	0.00	0.00	25,000.00	0.00
494-0080-69493	TRANSFER FROM 493	260,975.36	0.00	0.00	0.00	0.00	0.00	0.00
494-0080-69901	FUND BALANCE APPROPRIATED	0.00	4,917,323.00	8,473,023.00	0.00	0.00	8,473,023.00	0.00
Net - Dept 0080 - REVENUES		13,174,975.92	16,530,323.00	20,086,023.00	10,836,816.81	0.00	9,249,206.19	
Dept 9494 - DDA ADMIN EXPENDITURES								
494-9494-70300	APPOINTED OFFICIAL	166,096.08	181,160.00	181,160.00	136,118.60	0.00	45,041.40	75.14
494-9494-70703	CLERICAL CO-OP	24,503.80	35,000.00	35,000.00	7,850.00	0.00	27,150.00	22.43
494-9494-70705	TEMPORARY - INSPECTION	28,216.50	75,000.00	75,000.00	23,723.50	0.00	51,276.50	31.63
494-9494-71302	EDUCATION ALLOWANCE	0.00	2,000.00	2,000.00	0.00	0.00	2,000.00	0.00
494-9494-71303	CLEAN/CLOTHING ALLOWANCE	300.00	700.00	700.00	700.00	0.00	0.00	100.00
494-9494-71500	SOCIAL SECURITY	18,005.62	23,673.00	23,673.00	13,690.35	0.00	9,982.65	57.83
494-9494-71900	EMPLOYEE INSURANCES	26,117.73	91,156.00	91,156.00	30,301.71	0.00	60,854.29	33.24
494-9494-71904	RETIREE HEALTH INSURANCE	22,837.00	22,837.00	22,837.00	19,030.00	0.00	3,807.00	83.33
494-9494-71905	H.S.A. EXPENSE	3,726.31	3,989.00	3,989.00	3,003.73	0.00	985.27	75.30
494-9494-71906	SUPL LIFE INSURANCE EXP	0.00	500.00	500.00	0.00	0.00	500.00	0.00
494-9494-72100	LONGEVITY	3,453.48	7,219.00	7,219.00	2,230.12	0.00	4,988.88	30.89
494-9494-72101	BONUS/SICK REDEMPTION	2,914.80	8,330.00	8,330.00	4,288.70	0.00	4,041.30	51.48
494-9494-72201	DEFINED CONTRIBUTION EXP	18,631.02	19,941.00	19,941.00	15,018.72	0.00	4,922.28	75.32
494-9494-72700	OFFICE SUPPLIES	0.00	3,000.00	3,000.00	0.00	0.00	3,000.00	0.00
494-9494-80100	CONTRACTUAL SERVICES	341,323.59	0.00	500,000.00	290,390.52	200,864.26	8,745.22	98.25
494-9494-80200	POSTAGE	103.13	150.00	150.00	60.59	0.00	89.41	40.39
494-9494-85300	TELEPHONE & RADIO	271.44	700.00	700.00	217.20	0.00	482.80	31.03
494-9494-86100	MILEAGE	784.41	1,500.00	1,500.00	1,338.84	0.00	161.16	89.26
494-9494-86400	CONFERENCES & WORKSHOPS	2,753.07	7,800.00	7,800.00	0.00	0.00	7,800.00	0.00
494-9494-92000	PUBLIC UTILITIES	120.00	3,000.00	3,000.00	956.39	0.00	2,043.61	31.88
494-9494-95000	ADMINISTRATIVE COSTS	419,200.00	431,700.00	431,700.00	359,750.00	0.00	71,950.00	83.33
494-9494-95800	MEMBERSHIPS & DUES	7,700.00	12,000.00	12,000.00	700.00	2,785.00	8,515.00	29.04
494-9494-96123	CITY FLOWER PLANTINGS	14,455.00	30,000.00	30,000.00	0.00	16,715.00	13,285.00	55.72
494-9494-96391	TRANS TO 2013 (2002) DDA DEBT	1,548,089.00	1,458,059.00	1,458,059.00	1,458,059.00	0.00	0.00	100.00
494-9494-96392	TRANS TO 2023 DDA GEN OB #392	0.00	1,659,959.00	1,659,959.00	558,583.32	0.00	1,101,375.68	33.65
494-9494-96393	TRANS TO 2014 (2003&2004) DDA	3,342,600.00	3,220,525.00	3,220,525.00	3,220,525.00	0.00	0.00	100.00
494-9494-96394	TRANS TO 2015 (2005 DDA) DEBT	1,234,050.00	1,430,425.00	1,430,425.00	1,430,425.00	0.00	0.00	100.00
494-9494-97400	CAPITAL IMPROVEMENTS	1,357,232.96	7,800,000.00	10,855,700.00	2,182,882.68	3,186,468.94	5,486,348.38	49.46

REVENUE AND EXPENDITURE REPORT

PERIOD ENDING 04/30/2024

% Fiscal Year Completed: 83.33

GL NUMBER	DESCRIPTION	END BALANCE	2023-24		YTD BALANCE	ENCUMBERED	UNENCUMBERED	% BDGT
		06/30/2023	ORIGINAL	2023-24	04/30/2024			
		NORM (ABNORM)	BUDGET	AMENDED BUDGET	NORM (ABNORM)	YEAR-TO-DATE	BALANCE	USED
Fund 494 - DDA ADMINISTRATION FUND								
494-9494-98400	EQUIPMENT	2,084,572.14	0.00	0.00	0.00	0.00	0.00	0.00
Net - Dept 9494 - DDA ADMIN EXPENDITURES		(10,668,057.08)	(16,530,323.00)	(20,086,023.00)	(9,759,843.97)	(3,406,833.20)	(6,919,345.83)	
Fund 495 - TIFA CONSTRUCTION FUND								
Dept 0080 - REVENUES								
495-0080-40300	TAX COLLECTIONS	383,660.46	350,000.00	350,000.00	0.00	0.00	350,000.00	0.00
495-0080-57300	LOCAL COMM STABILIZ SHARE	1,207.69	4,000.00	4,000.00	0.00	0.00	4,000.00	0.00
495-0080-66500	INTEREST ON INVESTMENTS	662.73	2,500.00	2,500.00	736.84	0.00	1,763.16	29.47
495-0080-69901	FUND BALANCE APPROPRIATED	0.00	298,375.00	298,375.00	0.00	0.00	298,375.00	0.00
Net - Dept 0080 - REVENUES		385,530.88	654,875.00	654,875.00	736.84	0.00	654,138.16	
Dept 9495 - TIFA EXPENDITURES								
495-9495-70600	PERMANENT EMPLOYEES	8,335.03	18,000.00	18,000.00	6,848.85	0.00	11,151.15	38.05
495-9495-71900	EMPLOYEE INSURANCES	0.00	6,000.00	6,000.00	1,504.08	0.00	4,495.92	25.07
495-9495-72700	OFFICE SUPPLIES	0.00	500.00	500.00	0.00	0.00	500.00	0.00
495-9495-80100	CONTRACTUAL SERVICES	62,041.15	150,000.00	150,000.00	38,956.67	0.00	111,043.33	25.97
495-9495-80200	POSTAGE	0.00	25.00	25.00	2.51	0.00	22.49	10.04
495-9495-80204	FACADE IMPROVEMNT PROGRAM	0.00	100,000.00	100,000.00	0.00	0.00	100,000.00	0.00
495-9495-85300	TELEPHONE & RADIO	0.00	100.00	100.00	6.24	0.00	93.76	6.24
495-9495-88001	COMMUNITY PROMOTION/OUTREACH F	3,980.34	0.00	0.00	0.00	0.00	0.00	0.00
495-9495-92000	PUBLIC UTILITIES	0.00	250.00	250.00	178.12	0.00	71.88	71.25
495-9495-93000	BUILDING MAINTENANCE	20.51	5,000.00	5,000.00	2,802.05	0.00	2,197.95	56.04
495-9495-97400	CAPITAL IMPROVEMENTS	0.00	375,000.00	375,000.00	4,814.75	0.00	370,185.25	1.28
495-9495-98400	EQUIPMENT	3,895.22	0.00	0.00	0.00	0.00	0.00	0.00
Net - Dept 9495 - TIFA EXPENDITURES		(78,272.25)	(654,875.00)	(654,875.00)	(55,113.27)	0.00	(599,761.73)	
Fund 536 - SENIOR HOUSING - STILWELL								
Dept 0080 - REVENUES								
536-0080-62610	CLEANING FEES	3,130.00	0.00	0.00	1,474.00	0.00	(1,474.00)	100.00
536-0080-66500	INTEREST ON INVESTMENTS	0.00	1,500.00	1,500.00	0.00	0.00	1,500.00	0.00
536-0080-66701	RENTAL REV - ONE BEDROOM	441,433.00	453,794.00	453,794.00	390,719.00	0.00	63,075.00	86.10
536-0080-66702	RENTAL REV - TWO BEDROOM	36,567.00	38,645.00	38,645.00	35,501.00	0.00	3,144.00	91.86
536-0080-66703	RENTAL REV - EFF ROOMS	93,490.00	92,316.00	92,316.00	80,031.00	0.00	12,285.00	86.69
536-0080-67737	ADMIN EXPENSE - JOS COACH	454,181.00	479,377.00	479,377.00	397,430.00	0.00	81,947.00	82.91
536-0080-67900	MISCELLANEOUS REVENUE	23,600.70	20,000.00	20,000.00	18,251.73	0.00	1,748.27	91.26
536-0080-69901	FUND BALANCE APPROPRIATED	0.00	280,425.00	391,925.00	0.00	0.00	391,925.00	0.00
Net - Dept 0080 - REVENUES		1,052,401.70	1,366,057.00	1,477,557.00	923,406.73	0.00	554,150.27	

REVENUE AND EXPENDITURE REPORT

PERIOD ENDING 04/30/2024

% Fiscal Year Completed: 83.33

GL NUMBER	DESCRIPTION	END BALANCE	2023-24		YTD BALANCE	ENCUMBERED	UNENCUMBERED	% BDGT
		06/30/2023	ORIGINAL	2023-24	04/30/2024			
		NORM (ABNORM)	BUDGET	AMENDED BUDGET	NORM (ABNORM)	YEAR-TO-DATE	BALANCE	USED
Fund 536 - SENIOR HOUSING - STILWELL								
Dept 9536 - STILWELL MANOR EXPENSES								
536-9536-70600	PERMANENT EMPLOYEES	346,715.47	369,117.00	369,117.00	289,560.96	0.00	79,556.04	78.45
536-9536-70700	TEMPORARY EMPLOYEES	0.00	25,000.00	25,000.00	0.00	0.00	25,000.00	0.00
536-9536-70900	OVERTIME	5,922.37	6,000.00	6,000.00	5,380.88	0.00	619.12	89.68
536-9536-71303	CLEAN/CLOTHING ALLOWANCE	1,500.00	1,750.00	1,750.00	1,750.00	0.00	0.00	100.00
536-9536-71500	SOCIAL SECURITY	27,360.84	32,343.00	32,343.00	23,513.22	0.00	8,829.78	72.70
536-9536-71900	EMPLOYEE INSURANCES	96,748.69	112,388.00	112,388.00	91,689.16	0.00	20,698.84	81.58
536-9536-71904	RETIREE HEALTH INSURANCE	26,491.00	22,837.00	22,837.00	19,030.00	0.00	3,807.00	83.33
536-9536-71905	H.S.A. EXPENSE	7,382.64	7,956.00	7,956.00	6,336.69	0.00	1,619.31	79.65
536-9536-71906	SUPPL LIFE INSURANCE EXP	696.00	1,152.00	1,152.00	991.40	0.00	160.60	86.06
536-9536-72100	LONGEVITY	2,029.22	5,612.00	5,612.00	4,857.50	0.00	754.50	86.56
536-9536-72101	BONUS/SICK REDEMPTION	13,018.74	15,239.00	15,239.00	15,237.60	0.00	1.40	99.99
536-9536-72201	DEFINED CONTRIBUTION EXP	36,916.14	39,775.00	39,775.00	31,682.52	0.00	8,092.48	79.65
536-9536-72700	OFFICE SUPPLIES	1,397.30	2,000.00	2,000.00	268.60	1,681.40	50.00	97.50
536-9536-76001	PROGRAM ACTIVITY SUPPLIES	1,344.15	2,000.00	2,000.00	372.31	306.76	1,320.93	33.95
536-9536-77600	MAINTENANCE SUPPLIES	12,087.53	10,000.00	10,000.00	8,885.98	4,635.12	(3,521.10)	135.21
536-9536-80100	CONTRACTUAL SERVICES	85,804.81	132,550.00	132,550.00	83,315.47	86,010.63	(36,776.10)	127.75
536-9536-80200	POSTAGE	0.00	500.00	500.00	365.65	0.00	134.35	73.13
536-9536-85300	TELEPHONE & RADIO	13,425.11	15,200.00	15,200.00	3,932.65	205.43	11,061.92	27.22
536-9536-86300	VEHICLE MAINTENANCE	1,383.72	500.00	500.00	195.38	0.00	304.62	39.08
536-9536-91000	INSURANCE & BONDS	37,300.00	38,700.00	38,700.00	32,250.00	0.00	6,450.00	83.33
536-9536-92000	PUBLIC UTILITIES	183,171.99	175,000.00	175,000.00	136,829.91	0.00	38,170.09	78.19
536-9536-93000	BUILDING MAINTENANCE	25,553.76	76,500.00	76,500.00	11,147.79	5,847.71	59,504.50	22.22
536-9536-95000	ADMINISTRATIVE COSTS	84,000.00	86,500.00	86,500.00	72,080.00	0.00	14,420.00	83.33
536-9536-96807	PYMT TO CITY IN LIEU TAX	28,125.00	29,238.00	29,238.00	0.00	0.00	29,238.00	0.00
536-9536-96810	DEPR EXPENSE - REPLACEMENT COS	139,275.95	0.00	0.00	0.00	0.00	0.00	0.00
536-9536-98000	OFFICE EQUIPMENT	0.00	15,000.00	15,000.00	6,256.70	4,668.15	4,075.15	72.83
536-9536-98408	EQUIPMENT - MAINTENANCE	10,021.34	125,000.00	236,500.00	148,587.41	40,644.34	47,268.25	80.01
536-9536-98422	EQUIPMENT-APPLIANCES	10,777.15	18,200.00	18,200.00	3,771.41	5,228.59	9,200.00	49.45
Net - Dept 9536 - STILWELL MANOR EXPENSES		(1,198,448.92)	(1,366,057.00)	(1,477,557.00)	(998,289.19)	(149,228.13)	(330,039.68)	
TOTAL REVENUES		1,052,401.70	1,366,057.00	1,477,557.00	923,406.73	0.00	554,150.27	62.50
TOTAL EXPENDITURES		1,198,448.92	1,366,057.00	1,477,557.00	998,289.19	149,228.13	330,039.68	77.66
NET OF REVENUES & EXPENDITURES		(146,047.22)	0.00	0.00	(74,882.46)	(149,228.13)	224,110.59	100.00
Fund 537 - SENIOR HOUSING-JOS. COACH								
Dept 0080 - REVENUES								
537-0080-62610	CLEANING FEES	5,132.00	0.00	0.00	4,802.00	0.00	(4,802.00)	100.00
537-0080-66500	INTEREST ON INVESTMENTS	0.00	3,000.00	3,000.00	0.00	0.00	3,000.00	0.00
537-0080-66704	RENTAL REVENUES	1,653,370.96	1,717,525.00	1,717,525.00	1,422,970.00	0.00	294,555.00	82.85
537-0080-67900	MISCELLANEOUS REVENUE	15,514.56	17,500.00	17,500.00	14,367.88	0.00	3,132.12	82.10
537-0080-69901	FUND BALANCE APPROPRIATED	0.00	343,301.00	604,301.00	0.00	0.00	604,301.00	0.00
Net - Dept 0080 - REVENUES		1,674,017.52	2,081,326.00	2,342,326.00	1,442,139.88	0.00	900,186.12	
Dept 9537 - JOS COACH MANOR EXPENSES								
537-9537-70600	PERMANENT EMPLOYEES	129,743.81	130,448.00	130,448.00	102,949.98	0.00	27,498.02	78.92
537-9537-70700	TEMPORARY EMPLOYEES	12,465.00	25,000.00	25,000.00	7,537.50	0.00	17,462.50	30.15
537-9537-70900	OVERTIME	6,795.91	6,000.00	6,000.00	4,093.88	0.00	1,906.12	68.23
537-9537-71303	CLEAN/CLOTHING ALLOWANCE	900.00	1,050.00	1,050.00	1,050.00	0.00	0.00	100.00
537-9537-71500	SOCIAL SECURITY	11,147.80	12,894.00	12,894.00	8,561.82	0.00	4,332.18	66.40

REVENUE AND EXPENDITURE REPORT

PERIOD ENDING 04/30/2024

% Fiscal Year Completed: 83.33

GL NUMBER	DESCRIPTION	END BALANCE	2023-24		YTD BALANCE	ENCUMBERED	UNENCUMBERED	% BDGT
		06/30/2023	ORIGINAL	2023-24	04/30/2024			
		NORM (ABNORM)	BUDGET	AMENDED BUDGET	NORM (ABNORM)	YEAR-TO-DATE	BALANCE	USED
Fund 537 - SENIOR HOUSING-JOS. COACH								
537-9537-71900	EMPLOYEE INSURANCES	69,964.99	67,586.00	67,586.00	61,633.29	0.00	5,952.71	91.19
537-9537-71905	H.S.A. EXPENSE	2,748.38	2,871.00	2,871.00	2,162.12	0.00	708.88	75.31
537-9537-72101	BONUS/SICK REDEMPTION	0.00	5,999.00	5,999.00	0.00	0.00	5,999.00	0.00
537-9537-72201	DEFINED CONTRIBUTION EXP	13,742.58	14,351.00	14,351.00	10,810.92	0.00	3,540.08	75.33
537-9537-72700	OFFICE SUPPLIES	2,720.46	12,000.00	12,000.00	1,075.30	6,015.70	4,909.00	59.09
537-9537-76001	PROGRAM ACTIVITY SUPPLIES	3,015.91	6,000.00	6,000.00	1,208.41	920.31	3,871.28	35.48
537-9537-77600	MAINTENANCE SUPPLIES	32,646.89	30,000.00	30,000.00	14,513.07	4,971.19	10,515.74	64.95
537-9537-80100	CONTRACTUAL SERVICES	115,216.56	231,650.00	231,650.00	178,342.34	93,196.97	(39,889.31)	117.22
537-9537-80200	POSTAGE	196.47	1,500.00	1,500.00	384.06	0.00	1,115.94	25.60
537-9537-85300	TELEPHONE & RADIO	7,666.18	8,000.00	8,000.00	7,684.66	19.21	296.13	96.30
537-9537-86300	VEHICLE MAINTENANCE	339.97	1,500.00	1,500.00	0.00	0.00	1,500.00	0.00
537-9537-91000	INSURANCE & BONDS	27,000.00	28,000.00	28,000.00	23,340.00	0.00	4,660.00	83.36
537-9537-92000	PUBLIC UTILITIES	112,787.63	125,000.00	125,000.00	70,333.85	0.00	54,666.15	56.27
537-9537-93000	BUILDING MAINTENANCE	56,304.15	229,500.00	229,500.00	39,813.38	19,012.12	170,674.50	25.63
537-9537-95000	ADMINISTRATIVE COSTS	559,381.00	587,677.00	587,677.00	487,680.00	0.00	99,997.00	82.98
537-9537-96810	DEPR EXPENSE - REPLACEMENT COS	222,902.29	0.00	0.00	0.00	0.00	0.00	0.00
537-9537-98408	EQUIPMENT - MAINTENANCE	8,074.89	500,000.00	761,000.00	388,150.12	102,900.83	269,949.05	64.53
537-9537-98422	EQUIPMENT-APPLIANCES	35,772.45	54,300.00	54,300.00	16,662.63	4,337.37	33,300.00	38.67
537-9537-99500	BOND INTEREST PAID	1,125.00	0.00	0.00	0.00	0.00	0.00	0.00
537-9537-99800	AGENT FEES	20.83	0.00	0.00	0.00	0.00	0.00	0.00
Net - Dept 9537 - JOS COACH MANOR EXPENSES		(1,432,679.15)	(2,081,326.00)	(2,342,326.00)	(1,427,987.33)	(231,373.70)	(682,964.97)	
TOTAL REVENUES		1,674,017.52	2,081,326.00	2,342,326.00	1,442,139.88	0.00	900,186.12	61.57
TOTAL EXPENDITURES		1,432,679.15	2,081,326.00	2,342,326.00	1,427,987.33	231,373.70	682,964.97	70.84
NET OF REVENUES & EXPENDITURES		241,338.37	0.00	0.00	14,152.55	(231,373.70)	217,221.15	100.00
Fund 592 - WATER & SEWER SYSTEM FUND								
Dept 0080 - REVENUES								
592-0080-46000	UNMETERED WATER SALES	5,970.00	25,000.00	25,000.00	4,295.00	0.00	20,705.00	17.18
592-0080-46101	WATER SALES INDUSTRIAL	25,630,158.14	26,946,000.00	26,946,000.00	20,902,807.42	0.00	6,043,192.58	77.57
592-0080-46103	WATER SERVICE CHARGE	1,159,558.72	1,163,040.00	1,163,040.00	963,192.14	0.00	199,847.86	82.82
592-0080-46300	PUBLIC FIRE PROTECTION REVENUE	90,000.00	90,000.00	90,000.00	75,000.00	0.00	15,000.00	83.33
592-0080-47000	PENALTIES	802,880.34	975,000.00	975,000.00	727,103.50	0.00	247,896.50	74.57
592-0080-47100	MISCELLANEOUS INCOME	346,738.68	300,000.00	300,000.00	269,857.75	0.00	30,142.25	89.95
592-0080-47200	BUILDING RENTAL REVENUE	65,604.00	65,604.00	65,604.00	62,164.50	0.00	3,439.50	94.76
592-0080-47401	GAIN/LOSS SALE OF EQUIP	10,800.00	15,000.00	15,000.00	24,630.00	0.00	(9,630.00)	164.20
592-0080-47402	METER REPAIRS	12,132.00	15,000.00	15,000.00	8,399.25	0.00	6,600.75	56.00
592-0080-47404	OUTSIDE SERVICE	5,630.79	10,000.00	10,000.00	38,317.24	0.00	(28,317.24)	383.17
592-0080-47405	METER SALES	70,550.64	55,000.00	55,000.00	63,027.23	0.00	(8,027.23)	114.59
592-0080-47406	CENTER LINE TRANSMISSION	26,481.51	20,000.00	20,000.00	18,084.89	0.00	1,915.11	90.42
592-0080-47407	PRE-TREATMENT SURCHARGES	914,203.35	1,024,918.00	1,024,918.00	763,792.79	0.00	261,125.21	74.52
592-0080-47408	CROSS CONNECTION CHARGES	210,593.93	237,549.00	237,549.00	256,247.59	0.00	(18,698.59)	107.87
592-0080-47410	WWTP-OTHER INCOME	308,592.94	265,000.00	265,000.00	260,365.00	0.00	4,635.00	98.25
592-0080-47501	SEWAGE TREATMENT CHARGE	18,130,703.53	19,180,400.00	19,180,400.00	14,808,897.47	0.00	4,371,502.53	77.21
592-0080-47502	SEWER SERVICE CHARGE	2,711,614.06	2,729,750.00	2,729,750.00	2,250,747.91	0.00	479,002.09	82.45
592-0080-47503	STATE MANDATED FEE	5,080,783.71	5,349,600.00	5,349,600.00	4,151,944.32	0.00	1,197,655.68	77.61
592-0080-52800	OTHER FEDERAL GRANTS COVID19/A	6,729,972.18	0.00	0.00	461,190.29	0.00	(461,190.29)	100.00
592-0080-56900	SAW GRANT	212,114.10	0.00	0.00	54,021.87	0.00	(54,021.87)	100.00
592-0080-66500	INTEREST ON INVESTMENTS	1,028,335.98	168,040.00	168,040.00	1,403,809.91	0.00	(1,235,769.91)	835.40
592-0080-67601	TRANSFER FROM RET EARNING	0.00	10,289,110.00	13,750,187.00	0.00	0.00	13,750,187.00	0.00
Net - Dept 0080 - REVENUES		63,553,418.60	68,924,011.00	72,385,088.00	47,567,896.07	0.00	24,817,191.93	

REVENUE AND EXPENDITURE REPORT

PERIOD ENDING 04/30/2024

% Fiscal Year Completed: 83.33

GL NUMBER	DESCRIPTION	END BALANCE	2023-24		YTD BALANCE	ENCUMBERED	UNENCUMBERED	% BDGT
		06/30/2023	ORIGINAL	2023-24	04/30/2024			
		NORM (ABNORM)	BUDGET	AMENDED BUDGET	NORM (ABNORM)	YEAR-TO-DATE	BALANCE	USED
Fund 592 - WATER & SEWER SYSTEM FUND								
Dept 1537 - GENERAL								
592-1537-92700	WATER PURCHASES	11,248,234.46	11,155,000.00	11,155,000.00	7,171,136.72	0.00	3,983,863.28	64.29
592-1537-95100	BAD DEBT EXPENSE	(10,361.03)	100,000.00	100,000.00	0.00	0.00	100,000.00	0.00
Net - Dept 1537 - GENERAL		(11,237,873.43)	(11,255,000.00)	(11,255,000.00)	(7,171,136.72)	0.00	(4,083,863.28)	
Dept 1540 - WATER MAINTENANCE								
592-1540-70600	PERMANENT EMPLOYEES	2,252,745.06	2,797,440.00	2,797,440.00	1,775,057.75	0.00	1,022,382.25	63.45
592-1540-70700	TEMPORARY EMPLOYEES	124,318.06	204,880.00	204,880.00	137,306.20	0.00	67,573.80	67.02
592-1540-70900	OVERTIME	158,382.01	120,000.00	120,000.00	106,753.64	0.00	13,246.36	88.96
592-1540-71302	EDUCATION ALLOWANCE	15,382.69	23,500.00	23,500.00	16,223.29	1,135.00	6,141.71	73.87
592-1540-71303	CLEAN/CLOTHING ALLOWANCE	9,900.00	13,300.00	13,300.00	11,929.17	0.00	1,370.83	89.69
592-1540-71500	SOCIAL SECURITY	195,154.08	248,169.00	248,169.00	155,366.94	0.00	92,802.06	62.61
592-1540-71900	EMPLOYEE INSURANCES	780,549.25	902,522.00	902,522.00	436,696.77	0.00	465,825.23	48.39
592-1540-71904	RETIREE HEALTH INSURANCE	423,763.00	365,376.00	365,376.00	304,480.00	0.00	60,896.00	83.33
592-1540-71905	H.S.A. EXPENSE	40,571.11	52,617.00	52,617.00	32,325.72	0.00	20,291.28	61.44
592-1540-71906	SUPPL LIFE INSURANCE EXP	3,654.00	3,654.00	3,654.00	3,184.60	0.00	469.40	87.15
592-1540-72100	LONGEVITY	48,200.03	104,403.00	104,403.00	24,579.07	0.00	79,823.93	23.54
592-1540-72200	RETIREMENT FUND	2,004,834.00	1,260,138.00	1,260,138.00	1,050,120.00	0.00	210,018.00	83.33
592-1540-72201	DEFINED CONTRIBUTION EXP	216,478.28	277,688.00	277,688.00	174,147.64	0.00	103,540.36	62.71
592-1540-72401	UNIFORMS	(345.28)	0.00	0.00	0.00	0.00	0.00	0.00
592-1540-74000	OPERATING SUPPLIES	427,366.81	484,000.00	484,000.00	282,482.04	392,244.37	(190,726.41)	139.41
592-1540-78700	MATERIALS	333,188.87	100,000.00	100,000.00	94,029.24	0.00	5,970.76	94.03
592-1540-78900	METER REPLACEMENT	51,191.33	242,000.00	242,000.00	114,272.96	0.00	127,727.04	47.22
592-1540-80100	CONTRACTUAL SERVICES	848,071.79	750,000.00	750,000.00	311,195.44	35,487.96	403,316.60	46.22
592-1540-80250	DIRT REMOVAL	178,198.58	200,000.00	200,000.00	196,826.00	53,174.00	(50,000.00)	125.00
592-1540-80251	CONCRETE & SOD REPLACEMNT	1,646,714.93	1,200,000.00	1,200,000.00	305,409.10	0.00	894,590.90	25.45
592-1540-80253	ASSET MANAGEMENT PLAN EXPENSES	212,114.10	0.00	245,392.00	56,325.48	252,085.00	(63,018.48)	125.68
592-1540-80254	LEAD AND COPPER RULE REPLACEME	262,970.00	750,000.00	750,000.00	225,350.00	167,305.00	357,345.00	52.35
592-1540-80255	DWSRF GRANT EXPENSES	311.34	0.00	0.00	8,493.38	0.00	(8,493.38)	100.00
592-1540-85300	TELEPHONE & RADIO	21,262.52	40,000.00	40,000.00	18,695.10	231.06	21,073.84	47.32
592-1540-86300	VEHICLE MAINTENANCE	430,052.13	450,000.00	450,000.00	337,627.14	4,535.00	107,837.86	76.04
592-1540-92000	PUBLIC UTILITIES	103,017.03	110,000.00	110,000.00	72,058.15	0.00	37,941.85	65.51
592-1540-97500	FACILITY MAINTENANCE	22,170.43	260,040.00	260,040.00	13,525.46	32,396.77	214,117.77	17.66
Net - Dept 1540 - WATER MAINTENANCE		(10,810,216.15)	(10,959,727.00)	(11,205,119.00)	(6,264,460.28)	(938,594.16)	(4,002,064.56)	
Dept 1560 - ADMINISTRATION								
592-1560-70600	PERMANENT EMPLOYEES	1,474,696.39	1,714,992.00	1,714,992.00	1,116,957.61	0.00	598,034.39	65.13
592-1560-70700	TEMPORARY EMPLOYEES	0.00	0.00	0.00	10,416.25	0.00	(10,416.25)	100.00
592-1560-70900	OVERTIME	108,216.37	120,000.00	120,000.00	79,605.99	0.00	40,394.01	66.34
592-1560-71302	EDUCATION ALLOWANCE	8,630.00	10,000.00	10,000.00	12,878.45	0.00	(2,878.45)	128.78
592-1560-71303	CLEAN/CLOTHING ALLOWANCE	6,550.00	7,000.00	7,000.00	6,708.34	0.00	291.66	95.83
592-1560-71500	SOCIAL SECURITY	122,847.62	145,429.00	145,429.00	94,491.00	0.00	50,938.00	64.97
592-1560-71900	EMPLOYEE INSURANCES	349,406.73	372,258.00	372,258.00	190,566.25	0.00	181,691.75	51.19
592-1560-71904	RETIREE HEALTH INSURANCE	185,404.00	159,859.00	159,859.00	133,170.00	0.00	26,689.00	83.30
592-1560-71905	H.S.A. EXPENSE	27,221.24	32,817.00	32,817.00	20,416.83	0.00	12,400.17	62.21
592-1560-71906	SUPPL LIFE INSURANCE EXP	1,633.00	1,692.00	1,692.00	1,392.64	0.00	299.36	82.31
592-1560-72100	LONGEVITY	43,981.68	48,769.00	48,769.00	30,540.60	0.00	18,228.40	62.62
592-1560-72200	RETIREMENT FUND	637,901.00	400,953.00	400,953.00	334,130.00	0.00	66,823.00	83.33
592-1560-72201	DEFINED CONTRIBUTION EXP	162,258.56	191,077.00	191,077.00	123,082.84	0.00	67,994.16	64.42
592-1560-72401	UNIFORMS	(31.39)	0.00	0.00	0.00	0.00	0.00	0.00
592-1560-74000	OPERATING SUPPLIES	9,407.13	10,000.00	10,000.00	7,183.44	18,897.78	(16,081.22)	260.81
592-1560-80100	CONTRACTUAL SERVICES	169,122.13	450,000.00	450,000.00	155,240.72	16,006.89	278,752.39	38.06
592-1560-80105	INDEPENDENT AUDIT	18,200.00	18,700.00	18,700.00	18,700.00	0.00	0.00	100.00

REVENUE AND EXPENDITURE REPORT

PERIOD ENDING 04/30/2024

% Fiscal Year Completed: 83.33

GL NUMBER	DESCRIPTION	END BALANCE	2023-24		YTD BALANCE	ENCUMBERED	UNENCUMBERED	% BDGT
		06/30/2023	ORIGINAL	2023-24	04/30/2024			
		NORM (ABNORM)	BUDGET	AMENDED BUDGET	NORM (ABNORM)	YEAR-TO-DATE	BALANCE	USED
Fund 592 - WATER & SEWER SYSTEM FUND								
592-1560-80200	POSTAGE	264,029.81	275,000.00	275,000.00	265,967.40	200.00	8,832.60	96.79
592-1560-80300	UNEMPLOYMENT BENEFITS	0.00	5,000.00	5,000.00	0.00	0.00	5,000.00	0.00
592-1560-85300	TELEPHONE & RADIO	9,586.00	11,000.00	11,000.00	6,409.16	0.00	4,590.84	58.27
592-1560-86300	VEHICLE MAINTENANCE	2,496.84	1,000.00	1,000.00	2,751.18	0.00	(1,751.18)	275.12
592-1560-91000	INSURANCE & BONDS	600,000.00	600,000.00	600,000.00	500,000.00	0.00	100,000.00	83.33
592-1560-92000	PUBLIC UTILITIES	670.54	800.00	800.00	557.71	0.00	242.29	69.71
592-1560-95000	ADMINISTRATIVE COSTS	2,876,900.00	2,963,200.00	2,963,200.00	2,469,340.00	0.00	493,860.00	83.33
592-1560-96160	M.S.D.W.A. ANNUAL FEE	33,101.93	35,000.00	35,000.00	35,192.56	0.00	(192.56)	100.55
Net - Dept 1560 - ADMINISTRATION		(7,112,229.58)	(7,574,546.00)	(7,574,546.00)	(5,615,698.97)	(35,104.67)	(1,923,742.36)	
Dept 1580 - WWTP								
592-1580-70600	PERMANENT EMPLOYEES	2,976,506.43	3,472,737.00	3,472,737.00	2,437,269.96	0.00	1,035,467.04	70.18
592-1580-70700	TEMPORARY EMPLOYEES	3,135.34	80,000.00	80,000.00	5,835.00	0.00	74,165.00	7.29
592-1580-70900	OVERTIME	229,540.43	275,050.00	275,050.00	232,578.84	0.00	42,471.16	84.56
592-1580-71302	EDUCATION ALLOWANCE	27,657.07	59,500.00	59,500.00	42,274.58	8,050.00	9,175.42	84.58
592-1580-71303	CLEAN/CLOTHING ALLOWANCE	10,729.16	14,350.00	14,350.00	13,241.67	0.00	1,108.33	92.28
592-1580-71308	CERTIFICATION BONUSES	50,808.25	58,000.00	58,000.00	49,000.00	0.00	9,000.00	84.48
592-1580-71500	SOCIAL SECURITY	258,115.32	304,425.00	304,425.00	215,064.29	0.00	89,360.71	70.65
592-1580-71700	HOLIDAY PAY	68,117.68	80,870.00	80,870.00	37,401.42	0.00	43,468.58	46.25
592-1580-71900	EMPLOYEE INSURANCES	877,317.14	934,879.00	934,879.00	477,159.04	0.00	457,719.96	51.04
592-1580-71904	RETIREE HEALTH INSURANCE	662,159.00	570,925.00	570,925.00	475,780.00	0.00	95,145.00	83.33
592-1580-71905	H.S.A. EXPENSE	42,583.05	60,317.00	60,317.00	37,031.84	0.00	23,285.16	61.40
592-1580-71906	SUPPL LIFE INSURANCE EXP	3,658.00	3,658.00	3,658.00	3,688.96	0.00	(30.96)	100.85
592-1580-72100	LONGEVITY	73,587.77	86,352.00	86,352.00	60,713.74	0.00	25,638.26	70.31
592-1580-72200	RETIREMENT FUND	1,093,545.00	687,336.00	687,336.00	572,780.00	0.00	114,556.00	83.33
592-1580-72201	DEFINED CONTRIBUTION EXP	361,452.29	413,078.00	413,078.00	313,999.87	0.00	99,078.13	76.01
592-1580-72401	UNIFORMS	(303.42)	0.00	0.00	0.00	0.00	0.00	0.00
592-1580-74000	OPERATING SUPPLIES	51,680.91	70,000.00	70,000.00	25,592.82	17,742.97	26,664.21	61.91
592-1580-74300	CHEMICALS	191,419.51	300,000.00	300,000.00	197,239.21	136,386.02	(33,625.23)	111.21
592-1580-80100	CONTRACTUAL SERVICES	217,588.18	230,000.00	230,000.00	160,875.98	12,500.00	56,624.02	75.38
592-1580-80252	ODOR CONTROL	31,969.12	50,000.00	50,000.00	0.00	0.00	50,000.00	0.00
592-1580-81800	ASH REMOVAL	94,822.94	300,000.00	300,000.00	318,853.27	125,000.00	(143,853.27)	147.95
592-1580-85300	TELEPHONE & RADIO	43,572.98	65,000.00	65,000.00	37,186.30	1,099.01	26,714.69	58.90
592-1580-86300	VEHICLE MAINTENANCE	109,325.89	100,000.00	100,000.00	90,197.30	7,172.51	2,630.19	97.37
592-1580-92000	PUBLIC UTILITIES	852,223.70	900,000.00	900,000.00	400,684.87	0.00	499,315.13	44.52
592-1580-92005	ELECTRIC POWER	1,172,712.52	1,240,000.00	1,240,000.00	902,618.37	10,000.00	327,381.63	73.60
592-1580-93001	REPAIRS AND MAINTENANCE	673,148.94	700,000.00	736,270.00	518,598.88	473,165.77	(255,494.65)	134.70
592-1580-93020	HEALTH, SAFETY & SECURITY	280,771.58	250,000.00	250,000.00	197,547.88	169,145.17	(116,693.05)	146.68
592-1580-96201	MANAGEMENT AGENCY FEES	24,916.50	25,000.00	25,000.00	22,495.00	0.00	2,505.00	89.98
Net - Dept 1580 - WWTP		(10,482,761.28)	(11,331,477.00)	(11,367,747.00)	(7,845,709.09)	(960,261.45)	(2,561,776.46)	
Dept 9044 - EXPENSE								
592-9044-97001	CONTRACTS AWARDED	342,296.77	11,545,000.00	11,545,000.00	7,457,408.73	0.00	4,087,591.27	64.59
592-9044-97003	BOND ISSUANCE COSTS-WATER	286,549.00	0.00	0.00	0.00	0.00	0.00	0.00
Net - Dept 9044 - EXPENSE		(628,845.77)	(11,545,000.00)	(11,545,000.00)	(7,457,408.73)	0.00	(4,087,591.27)	
Dept 9047 - EXPENSE								
592-9047-98040	EQUIPMENT - WATER MAINT	197,786.60	800,000.00	2,744,881.00	1,149,437.71	595,609.65	999,833.64	63.57
592-9047-98080	EQUIPMENT - WWTP	713,494.01	3,450,000.00	4,684,534.00	3,220,463.53	1,154,627.88	309,442.59	93.39
Net - Dept 9047 - EXPENSE		(911,280.61)	(4,250,000.00)	(7,429,415.00)	(4,369,901.24)	(1,750,237.53)	(1,309,276.23)	

REVENUE AND EXPENDITURE REPORT

PERIOD ENDING 04/30/2024

% Fiscal Year Completed: 83.33

GL NUMBER	DESCRIPTION	END BALANCE	2023-24		YTD BALANCE	ENCUMBERED	UNENCUMBERED	% BDGT
		06/30/2023	ORIGINAL	2023-24	04/30/2024			
		NORM (ABNORM)	BUDGET	AMENDED BUDGET	NORM (ABNORM)	YEAR-TO-DATE	BALANCE	USED
Fund 592 - WATER & SEWER SYSTEM FUND								
Dept 9072 - EXPENSE								
592-9072-99603	BLDG AUTH BOND INTEREST	3,403.12	0.00	0.00	0.00	0.00	0.00	0.00
592-9072-99604	CAP IMP BOND PRINCIPAL	0.00	6,741,496.00	6,741,496.00	5,416,496.01	0.00	1,324,999.99	80.35
592-9072-99605	CAP IMP BOND INTEREST	3,823,432.21	3,758,553.00	3,758,553.00	2,809,346.89	0.00	949,206.11	74.75
592-9072-99606	SRF BOND PRINCIPAL	0.00	1,345,000.00	1,345,000.00	1,345,000.00	0.00	0.00	100.00
592-9072-99607	SRF BOND INTEREST	113,286.16	92,527.00	92,527.00	92,526.78	0.00	0.22	100.00
592-9072-99611	CAP EQUIP PRINCIPAL	0.00	697,832.00	697,832.00	697,832.47	0.00	(0.47)	100.00
592-9072-99613	INSTALLMENT PUR INTEREST	91,135.12	84,254.00	84,254.00	84,253.53	0.00	0.47	100.00
592-9072-99700	OTHER COSTS	4,184.39	4,000.00	4,000.00	3,892.73	0.00	107.27	97.32
Net - Dept 9072 - EXPENSE		(4,035,441.00)	(12,723,662.00)	(12,723,662.00)	(10,449,348.41)	0.00	(2,274,313.59)	
TOTAL REVENUES		63,553,418.60	68,924,011.00	72,385,088.00	47,567,896.07	0.00	24,817,191.93	65.72
TOTAL EXPENDITURES		45,218,647.82	69,639,412.00	73,100,489.00	49,173,663.44	3,684,197.81	20,242,627.75	72.31
NET OF REVENUES & EXPENDITURES		18,334,770.78	(715,401.00)	(715,401.00)	(1,605,767.37)	(3,684,197.81)	4,574,564.18	739.44
Fund 701 - UNALLOCATED TAX FUND								
Dept 0080 - REVENUES								
701-0080-40300	TAX COLLECTIONS	245,248,496.62	0.00	0.00	264,030,180.46	0.00	(264,030,180.46)	100.00
Net - Dept 0080 - REVENUES		245,248,496.62	0.00	0.00	264,030,180.46	0.00	(264,030,180.46)	
Dept 9701 - UNALLOCATED TAX EXPEND								
701-9701-80001	PAID WARREN CONSOLIDATED	27,038,616.58	0.00	0.00	29,630,253.35	0.00	(29,630,253.35)	100.00
701-9701-80002	PAID CENTER LINE SCHOOLS	6,847,035.61	0.00	0.00	7,409,785.39	0.00	(7,409,785.39)	100.00
701-9701-80003	PAID WARREN WOODS SCHOOLS	8,359,810.30	0.00	0.00	9,299,909.86	0.00	(9,299,909.86)	100.00
701-9701-80004	PAID VAN DYKE SCHOOLS	9,824,914.09	0.00	0.00	10,139,812.73	0.00	(10,139,812.73)	100.00
701-9701-80005	PAID FITZGERALD SCHOOLS	8,495,384.92	0.00	0.00	9,839,509.57	0.00	(9,839,509.57)	100.00
701-9701-80006	PAID EAST DETROIT SCHOOLS	1,818,459.89	0.00	0.00	1,977,118.99	0.00	(1,977,118.99)	100.00
701-9701-80007	PAID COUNTY TREASURER-TAX	21,693,029.38	0.00	0.00	22,879,697.18	0.00	(22,879,697.18)	100.00
701-9701-80008	PAID STATE OF MICHIGAN	2,205,722.38	0.00	0.00	0.00	0.00	0.00	0.00
701-9701-80009	PAID MACOMB COUNTY COLLEG	5,238,258.26	0.00	0.00	5,513,404.82	0.00	(5,513,404.82)	100.00
701-9701-80010	PAID MACOMB INTERMEDIATE	18,188,571.84	0.00	0.00	19,614,453.86	0.00	(19,614,453.86)	100.00
701-9701-80011	PD COUNTY-MI S.E.T. TAX	23,072,020.47	0.00	0.00	24,509,411.47	0.00	(24,509,411.47)	100.00
701-9701-80013	PD MACOMB CO - LATE FEES	16,559.19	0.00	0.00	0.00	0.00	0.00	0.00
701-9701-96204	TRANSFER TO RDS SPEC REV	7,439,165.84	0.00	0.00	6,863,440.00	0.00	(6,863,440.00)	100.00
701-9701-96208	TRANSFER TO REC SPEC REV	3,438,054.66	0.00	0.00	3,168,720.00	0.00	(3,168,720.00)	100.00
701-9701-96226	TRANSFER TO SAN SPEC REV	10,320,085.36	0.00	0.00	9,509,240.00	0.00	(9,509,240.00)	100.00
701-9701-96247	TRANS TO TIFA OPERATING	383,660.46	0.00	0.00	0.00	0.00	0.00	0.00
701-9701-96271	TRANSFER TO LIB SPEC REV	4,715,476.94	0.00	0.00	4,347,510.00	0.00	(4,347,510.00)	100.00
701-9701-96280	TRANS TO BROWNFIELD AUTH	1,432,968.15	0.00	0.00	0.00	0.00	0.00	0.00
701-9701-96301	TRANS TO GENERAL FUND	74,945,300.26	0.00	0.00	68,946,280.00	0.00	(68,946,280.00)	100.00
701-9701-96302	TRANS TO GENL FUND- WEEDS	41,100.93	0.00	0.00	0.00	0.00	0.00	0.00
701-9701-96303	TRANS GENL FUND ADMIN FEE	1,350,332.38	0.00	0.00	0.00	0.00	0.00	0.00
701-9701-96304	TRANS GENL FUND-PENALTIES	284,706.88	0.00	0.00	0.00	0.00	0.00	0.00
701-9701-96494	TRANS TO DDA ADMIN FUND	7,448,299.95	0.00	0.00	6,094,160.00	0.00	(6,094,160.00)	100.00
701-9701-96500	REFUND OF CURRENT TAXES	378,803.98	0.00	0.00	456,017.41	0.00	(456,017.41)	100.00
701-9701-96592	TRANSFER TO WATER & SEWER	194,309.53	0.00	0.00	0.00	0.00	0.00	0.00
701-9701-96704	TRANS TO S/A FUND 802	77,848.39	0.00	0.00	0.00	0.00	0.00	0.00
Net - Dept 9701 - UNALLOCATED TAX EXPEND		(245,248,496.62)	0.00	0.00	(240,198,724.63)	0.00	240,198,724.63	

REVENUE AND EXPENDITURE REPORT

PERIOD ENDING 04/30/2024

% Fiscal Year Completed: 83.33

GL NUMBER	DESCRIPTION	END BALANCE	2023-24		YTD BALANCE	ENCUMBERED	UNENCUMBERED	% BDGT
		06/30/2023	ORIGINAL	2023-24	04/30/2024			
		NORM (ABNORM)	BUDGET	AMENDED BUDGET	NORM (ABNORM)	YEAR-TO-DATE	BALANCE	USED
Fund 900 - GASB 34 FULL ACCRUAL FUND								
900-0000-96815	DEPR EXPENSE - REC & CULTURE	1,946,898.59	0.00	0.00	0.00	0.00	0.00	0.00
900-0000-96816	DEPR EXPENSE - HIGHWAYS & STRE	5,699,622.88	0.00	0.00	0.00	0.00	0.00	0.00
900-0000-98511	CAPITAL OUTLAY - GENERAL GOV	927,487.53	0.00	0.00	0.00	0.00	0.00	0.00
900-0000-98512	CAPITAL OUTLAY - PUBLIC SAFETY	5,023,274.97	0.00	0.00	0.00	0.00	0.00	0.00
900-0000-98513	CAPITAL OUTLAY - CITY DEV	2,716,660.36	0.00	0.00	0.00	0.00	0.00	0.00
900-0000-98514	CAPITAL OUTLAY - SANITATION	338,923.63	0.00	0.00	0.00	0.00	0.00	0.00
900-0000-98515	CAPITAL OUTLAY - REC & CULTURE	3,573,146.12	0.00	0.00	0.00	0.00	0.00	0.00
900-0000-98516	CAPITAL OUTLAY - HIGHWAYS & SI	28,095,152.01	0.00	0.00	0.00	0.00	0.00	0.00
Net - Dept 0000		24,851,053.70	0.00	0.00	0.00	0.00	0.00	
Dept 0080 - REVENUES								
900-0080-47401	GAIN/LOSS SALE OF EQUIP	(113,705.65)	0.00	0.00	0.00	0.00	0.00	0.00
Net - Dept 0080 - REVENUES		(113,705.65)	0.00	0.00	0.00	0.00	0.00	
TOTAL REVENUES								
		40,560,938.97	0.00	0.00	0.00	0.00	0.00	0.00
TOTAL EXPENDITURES								
		15,823,590.92	0.00	0.00	0.00	0.00	0.00	0.00
NET OF REVENUES & EXPENDITURES								
		24,737,348.05	0.00	0.00	0.00	0.00	0.00	0.00
TOTAL REVENUES - ALL FUNDS								
		607,590,389.85	320,544,477.09	364,160,623.39	518,520,850.65	0.00	(154,360,227.26)	142.39
TOTAL EXPENDITURES - ALL FUNDS								
		532,837,422.74	325,975,858.82	369,592,005.12	474,174,499.85	22,308,792.08	(126,891,286.81)	134.33
NET OF REVENUES & EXPENDITURES								
		74,752,967.11	(5,431,381.73)	(5,431,381.73)	44,346,350.80	(22,308,792.08)	(27,468,940.45)	405.74

REVENUE AND EXPENDITURE REPORT

PERIOD ENDING 04/30/2024

% Fiscal Year Completed: 83.33

GL NUMBER	DESCRIPTION	END BALANCE	2023-24		YTD BALANCE	ENCUMBERED	UNENCUMBERED	% BDGT
		06/30/2023	ORIGINAL	2023-24	04/30/2024			
		NORM (ABNORM)	BUDGET	AMENDED BUDGET	NORM (ABNORM)	YEAR-TO-DATE	BALANCE	USED
TAXES								
101-0080-40300	TAX COLLECTIONS	16,954.00	0.00	0.00	13,137.49	0.00	(13,137.49)	100.00
101-0080-40301	PROPERTY TAXES: CHARTER	32,046,090.04	33,808,316.00	33,808,316.00	28,342,297.08	0.00	5,466,018.92	83.83
101-0080-40303	PROPERTY TAX: P&F PENSION	19,235,040.49	20,240,407.00	20,240,407.00	16,967,048.90	0.00	3,273,358.10	83.83
101-0080-40305	PROPERTY TAX: EMS	1,076,014.44	1,124,738.00	1,124,738.00	942,892.13	0.00	181,845.87	83.83
101-0080-40306	PROPERTY TAX: POLICE	3,574,839.50	3,771,729.00	3,771,729.00	3,161,924.90	0.00	609,804.10	83.83
101-0080-40307	PROPERTY TAX: FIRE	3,574,840.40	3,771,729.00	3,771,729.00	3,161,924.90	0.00	609,804.10	83.83
101-0080-40311	PROPERTY TAX: P&F OPER.	17,957,963.95	18,978,832.00	18,978,832.00	15,910,370.91	0.00	3,068,461.09	83.83
101-0080-40400	PYMT IN LIEU OF PROP TAX	28,125.00	29,238.00	29,238.00	0.00	0.00	29,238.00	0.00
101-0080-40500	TRAILER PARK TAXES	6,049.00	3,762.00	3,762.00	4,613.50	0.00	(851.50)	122.63
101-0080-43701	IF TAX: CHARTER	210,929.79	430,295.00	430,295.00	358,580.00	0.00	71,715.00	83.33
101-0080-43703	IF TAX: P&F PENSION	162,251.41	257,612.00	257,612.00	214,680.00	0.00	42,932.00	83.33
101-0080-43705	IF TAX: EMS	7,017.02	14,315.00	14,315.00	11,930.00	0.00	2,385.00	83.34
101-0080-43706	IF TAX: POLICE	23,531.59	48,000.00	48,000.00	40,000.00	0.00	8,000.00	83.33
101-0080-43707	IF TAX: FIRE	23,531.59	48,000.00	48,000.00	40,000.00	0.00	8,000.00	83.33
101-0080-43711	IF TAX: POLICE & FIRE OP	118,408.69	241,550.00	241,550.00	201,290.00	0.00	40,260.00	83.33
101-0080-44500	PENALTIES & INT ON TAXES	450,984.39	300,000.00	300,000.00	34,166.50	0.00	265,833.50	11.39
204-0080-40300	TAX COLLECTIONS	1,078.46	0.00	0.00	1,098.72	0.00	(1,098.72)	100.00
204-0080-40310	PROPERTY TAXES: ROAD MILL	7,712,526.85	8,132,625.00	8,132,625.00	6,821,739.96	0.00	1,310,885.04	83.88
204-0080-43710	IF TAX: ROAD MILLAGE	50,739.22	103,504.00	103,504.00	86,250.00	0.00	17,254.00	83.33
208-0080-40300	TAX COLLECTIONS	942.20	0.00	0.00	659.50	0.00	(659.50)	100.00
208-0080-40308	PROPERTY TAX : RECREATION	3,555,664.39	3,754,675.00	3,754,675.00	3,147,634.71	0.00	607,040.29	83.83
208-0080-43708	IF TAX : RECREATION	23,425.20	47,783.00	47,783.00	39,820.00	0.00	7,963.00	83.34
226-0080-40300	TAX COLLECTIONS	2,286.89	0.00	0.00	1,753.46	0.00	(1,753.46)	100.00
226-0080-40304	PROPERTY TAX: SANITATION	10,669,604.32	11,267,679.00	11,267,679.00	9,444,846.28	0.00	1,822,832.72	83.82
226-0080-43704	IF TAX: SANITATION	70,298.83	143,411.00	143,411.00	119,510.00	0.00	23,901.00	83.33
271-0080-40300	TAX COLLECTIONS	823.73	0.00	0.00	727.68	0.00	(727.68)	100.00
271-0080-40302	PROPERTY TAX: LIBRARY	4,872,680.64	5,151,461.00	5,151,461.00	4,317,316.46	0.00	834,144.54	83.81
271-0080-43702	IF TAX: LIBRARY	32,139.79	65,560.00	65,560.00	54,630.00	0.00	10,930.00	83.33
385-0080-40300	TAX COLLECTIONS	0.00	0.00	0.00	2.84	0.00	(2.84)	100.00
492-0080-40601	TAXES - LIPARI WBCE PROPERTIES	424,179.30	0.00	0.00	0.00	0.00	0.00	0.00
492-0080-40602	TAXES - DKM HOLDINGS	104,157.47	0.00	0.00	0.00	0.00	0.00	0.00
492-0080-40603	TAXES - UNIVERSAL PROP.	265,395.28	0.00	0.00	0.00	0.00	0.00	0.00
492-0080-40604	TAXES - STAR WARREN	15,944.82	0.00	0.00	0.00	0.00	0.00	0.00
492-0080-40605	TAXES - MEIJER	416,057.63	0.00	0.00	0.00	0.00	0.00	0.00
494-0080-40309	PROPERTY TAXES: DDA	7,296,426.51	7,313,000.00	7,313,000.00	6,094,160.00	0.00	1,218,840.00	83.33
495-0080-40300	TAX COLLECTIONS	383,660.46	350,000.00	350,000.00	0.00	0.00	350,000.00	0.00
701-0080-40300	TAX COLLECTIONS	245,248,496.62	0.00	0.00	264,030,180.46	0.00	(264,030,180.46)	100.00
801-0080-42500	SPECIAL ASSESSMENTS	27,795.75	0.00	0.00	0.00	0.00	0.00	0.00
801-0080-44500	PENALTIES & INT ON TAXES	3,405.07	0.00	0.00	394.00	0.00	(394.00)	100.00
802-0080-42500	SPECIAL ASSESSMENTS	361,277.50	0.00	0.00	0.00	0.00	0.00	0.00
802-0080-44500	PENALTIES & INT ON TAXES	4,168.45	0.00	0.00	267.50	0.00	(267.50)	100.00
Net TAXES		360,055,746.68	119,398,221.00	119,398,221.00	363,565,847.88	0.00	(244,167,626.88)	304.50

OTHER REVENUES

592-0080-46000	UNMETERED WATER SALES	5,970.00	25,000.00	25,000.00	4,295.00	0.00	20,705.00	17.18
592-0080-46103	WATER SERVICE CHARGE	1,159,558.72	1,163,040.00	1,163,040.00	963,192.14	0.00	199,847.86	82.82
592-0080-46300	PUBLIC FIRE PROTECTION REVENUE	90,000.00	90,000.00	90,000.00	75,000.00	0.00	15,000.00	83.33
592-0080-47000	PENALTIES	802,880.34	975,000.00	975,000.00	727,103.50	0.00	247,896.50	74.57
592-0080-47100	MISCELLANEOUS INCOME	346,738.68	300,000.00	300,000.00	269,857.75	0.00	30,142.25	89.95
592-0080-47200	BUILDING RENTAL REVENUE	65,604.00	65,604.00	65,604.00	62,164.50	0.00	3,439.50	94.76
592-0080-47401	GAIN/LOSS SALE OF EQUIP	10,800.00	15,000.00	15,000.00	24,630.00	0.00	(9,630.00)	164.20
592-0080-47402	METER REPAIRS	12,132.00	15,000.00	15,000.00	8,399.25	0.00	6,600.75	56.00
592-0080-47404	OUTSIDE SERVICE	5,630.79	10,000.00	10,000.00	38,317.24	0.00	(28,317.24)	383.17
592-0080-47405	METER SALES	70,550.64	55,000.00	55,000.00	63,027.23	0.00	(8,027.23)	114.59
592-0080-47406	CENTER LINE TRANSMISSION	26,481.51	20,000.00	20,000.00	18,084.89	0.00	1,915.11	90.42
592-0080-47408	CROSS CONNECTION CHARGES	210,593.93	237,549.00	237,549.00	256,247.59	0.00	(18,698.59)	107.87

REVENUE AND EXPENDITURE REPORT

PERIOD ENDING 04/30/2024

% Fiscal Year Completed: 83.33

GL NUMBER	DESCRIPTION	END BALANCE	2023-24		YTD BALANCE	ENCUMBERED	UNENCUMBERED	% BDGT
		06/30/2023	ORIGINAL	2023-24	04/30/2024			
		NORM (ABNORM)	BUDGET	AMENDED BUDGET	NORM (ABNORM)	YEAR-TO-DATE	BALANCE	USED
278-0080-53100	DRAWDOWN	766,948.78	1,379,229.00	1,379,229.00	711,928.82	0.00	667,300.18	51.62
278-0080-53102	PROGRAM INCOME	0.00	2,535.03	208,484.29	0.00	0.00	208,484.29	0.00
278-0080-53118	HUD CARES ACT FUNDING	39,742.18	0.00	0.00	0.00	0.00	0.00	0.00
279-0080-53102	PROGRAM INCOME	15,029.75	0.00	0.00	14,213.97	0.00	(14,213.97)	100.00
280-0080-53100	DRAWDOWN	15,075.13	0.00	0.00	0.00	0.00	0.00	0.00
280-0080-53102	PROGRAM INCOME	(1,551.67)	0.00	0.00	0.00	0.00	0.00	0.00
281-0080-53101	HEALTHY HOMES SUPPLEMENTAL GRA	49,290.00	250,710.00	250,710.00	0.00	0.00	250,710.00	0.00
281-0080-53119	LEAD HAZARD CONTROL GRANT 2019	181,557.36	775,823.66	775,823.66	190,490.25	0.00	585,333.41	24.55
281-0080-53203	MATCH	15,419.50	106,235.83	106,235.83	5,224.50	0.00	101,011.33	4.92
592-0080-52800	OTHER FEDERAL GRANTS COVID19/A	6,729,972.18	0.00	0.00	461,190.29	0.00	(461,190.29)	100.00
Net FEDERAL GRANTS		11,289,273.94	6,861,142.09	11,152,578.90	3,590,017.21	0.00	7,562,561.69	32.19
CHARGES FOR SERVICES								
101-0080-53601	COMMUNITY DEV ADMIN	98,553.79	195,000.00	195,000.00	63,637.83	0.00	131,362.17	32.63
101-0080-53604	COMM DEV REIMB	80,000.00	90,000.00	90,000.00	70,907.38	0.00	19,092.62	78.79
101-0080-60800	BOARD OF APPEALS	32,690.00	40,000.00	40,000.00	23,445.00	0.00	16,555.00	58.61
101-0080-60900	TAX COLL FEE - NON CITY	1,425,165.88	1,300,000.00	1,300,000.00	6,042.53	0.00	1,293,957.47	0.46
101-0080-61100	CITY CLERK	128,812.50	208,624.00	208,624.00	108,894.20	0.00	99,729.80	52.20
101-0080-62100	SITE PLANS FEES	54,220.00	45,000.00	45,000.00	76,563.40	0.00	(31,563.40)	170.14
101-0080-62200	PLANNING COMMISSION FEES	32,226.44	30,000.00	30,000.00	13,875.00	0.00	16,125.00	46.25
101-0080-62300	PROCESSING PA 198 IFT CER	2,500.00	1,500.00	1,500.00	1,000.00	0.00	500.00	66.67
101-0080-62700	FORESTRY - TREE PLANTING	400.00	0.00	0.00	200.00	0.00	(200.00)	100.00
101-0080-62900	REIMB JUDGES' SAL STANDZN	156,165.08	182,896.00	182,896.00	137,172.00	0.00	45,724.00	75.00
101-0080-62910	ELECTION EXP REIMBURSEMNT	91,912.02	132,000.00	132,000.00	34,055.08	0.00	97,944.92	25.80
101-0080-63100	REIMBURSE FROM SCHOOLS	565,598.66	490,000.00	490,000.00	180,000.00	0.00	310,000.00	36.73
101-0080-63400	ENGINEERING & INSP FEES	121,822.00	80,000.00	80,000.00	67,597.50	0.00	12,402.50	84.50
101-0080-63404	FORECLOSURE FEE	67,350.00	70,000.00	70,000.00	67,100.00	0.00	2,900.00	95.86
101-0080-63700	TOWING ADMIN FEE	189,550.00	180,000.00	180,000.00	130,350.00	0.00	49,650.00	72.42
101-0080-63800	POLICE FEES	400,136.00	250,000.00	250,000.00	345,884.32	0.00	(95,884.32)	138.35
101-0080-63900	FIRE REVENUES	24,360.84	15,000.00	15,000.00	37,500.55	0.00	(22,500.55)	250.00
101-0080-63901	EMS REVENUE	4,111,489.69	3,800,000.00	3,800,000.00	2,943,489.73	0.00	856,510.27	77.46
101-0080-64100	WEED CUTTING	102,880.97	175,000.00	175,000.00	80,006.25	0.00	94,993.75	45.72
208-0080-65101	RECREATION FEES	169,554.35	175,000.00	175,000.00	157,154.82	0.00	17,845.18	89.80
208-0080-65102	DOWNTOWN SKATE RINK FEES	695.00	15,000.00	15,000.00	3,530.00	0.00	11,470.00	23.53
208-0080-65103	COMMUNITY CENTER FEES	514,771.48	925,000.00	925,000.00	570,513.98	0.00	354,486.02	61.68
208-0080-65104	BINGO FEES	0.00	350.00	350.00	0.00	0.00	350.00	0.00
208-0080-65106	SPONSORED EVENTS REVENUE	44,248.60	40,000.00	40,000.00	34,087.79	0.00	5,912.21	85.22
208-0080-65108	SENIOR TRANSPORTATION	0.00	20,000.00	20,000.00	0.00	0.00	20,000.00	0.00
208-0080-65110	SPECIAL EVENTS REVENUE	1,919.00	70,000.00	70,000.00	1,485.00	0.00	68,515.00	2.12
230-0080-63401	RESIDENTIAL INSP FEES	1,118,685.00	1,050,000.00	1,050,000.00	914,220.00	0.00	135,780.00	87.07
230-0080-63402	APARTMENT INSPECTION FEE	29,825.00	145,000.00	145,000.00	119,940.00	0.00	25,060.00	82.72
271-0080-62611	COPY MACHINE REVENUE	26,429.20	30,000.00	30,000.00	24,807.24	0.00	5,192.76	82.69
271-0080-62613	VIDEO CASSETTE USER FEES	1,069.29	2,000.00	2,000.00	811.01	0.00	1,188.99	40.55
271-0080-62615	NON-RESIDENT INTERNET FEE	2,613.00	8,000.00	8,000.00	2,248.00	0.00	5,752.00	28.10
271-0080-65105	NON-RESIDENT ROOM USE	648.05	0.00	0.00	1,030.00	0.00	(1,030.00)	100.00
536-0080-62610	CLEANING FEES	3,130.00	0.00	0.00	1,474.00	0.00	(1,474.00)	100.00
537-0080-62610	CLEANING FEES	5,132.00	0.00	0.00	4,802.00	0.00	(4,802.00)	100.00
Net CHARGES FOR SERVICES		9,604,553.84	9,765,370.00	9,765,370.00	6,223,824.61	0.00	3,541,545.39	63.73
STATE GRANTS								
101-0080-53619	STATE HOMELAND SEC GRT	3,286.42	0.00	0.00	0.00	0.00	0.00	0.00
101-0080-53692	MICH DRUG COURT GRT FY22 REV	6,408.59	0.00	0.00	0.00	0.00	0.00	0.00
101-0080-53694	MICH DRUG COURT GRT FY23 REV	44,760.12	0.00	0.00	12,823.00	0.00	(12,823.00)	100.00
101-0080-53698	MICH DRUG COURT GRT FY24 REV	0.00	0.00	23,000.00	2,535.00	0.00	20,465.00	11.02
101-0080-55900	MEDICAL MARIJUANA EXCISE TAX	9,145.48	0.00	0.00	39,485.06	0.00	(39,485.06)	100.00
101-0080-57300	LOCAL COMM STABILIZ SHARE	4,236,589.49	6,000,000.00	6,000,000.00	3,794,726.59	0.00	2,205,273.41	63.25
101-0080-57502	SALES TAXES	18,032,702.00	18,560,248.00	18,560,248.00	12,496,649.00	0.00	6,063,599.00	67.33

REVENUE AND EXPENDITURE REPORT

PERIOD ENDING 04/30/2024

% Fiscal Year Completed: 83.33

GL NUMBER	DESCRIPTION	END BALANCE	2023-24		YTD BALANCE	ENCUMBERED	UNENCUMBERED	% BDGT
		06/30/2023	ORIGINAL	2023-24	04/30/2024			
		NORM (ABNORM)	BUDGET	AMENDED BUDGET	NORM (ABNORM)	YEAR-TO-DATE	BALANCE	USED
101-0080-57504	LIQUOR LICENSES	99,141.35	80,000.00	80,000.00	86,763.60	0.00	(6,763.60)	108.45
202-0080-54900	WEIGHT AND GAS TAX	13,081,122.50	13,259,400.00	13,259,400.00	9,120,083.15	0.00	4,139,316.85	68.78
203-0080-54900	WEIGHT AND GAS TAX	4,359,520.77	4,418,250.00	4,418,250.00	3,043,228.65	0.00	1,375,021.35	68.88
204-0080-57300	LOCAL COMM STABILIZ SHARE	1,007,033.44	320,000.00	320,000.00	433,586.29	0.00	(113,586.29)	135.50
208-0080-56605	MDOT - RECREATION	74,285.00	74,285.00	74,285.00	70,736.50	0.00	3,548.50	95.22
208-0080-56607	SMART-COMMUNITY CR. GRANT	191,612.00	147,760.00	147,760.00	54,924.00	0.00	92,836.00	37.17
208-0080-56608	COMMUNITY ENHANCEMENT GRANT	0.00	0.00	1,500,000.00	0.00	0.00	1,500,000.00	0.00
208-0080-57300	LOCAL COMM STABILIZ SHARE	464,940.77	375,000.00	375,000.00	200,178.37	0.00	174,821.63	53.38
226-0080-57300	LOCAL COMM STABILIZ SHARE	1,395,218.16	440,000.00	440,000.00	600,729.92	0.00	(160,729.92)	136.53
259-0080-53901	INDIGENT DEFENSE GRANT	377,565.01	0.00	3,429,761.03	1,806,886.18	0.00	1,622,874.85	52.68
262-0080-54400	POLICE TRAINING	47,452.14	22,000.00	72,000.00	78,593.82	0.00	(6,593.82)	109.16
271-0080-54200	STATE AID	141,348.44	90,000.00	90,000.00	70,178.28	0.00	19,821.72	77.98
271-0080-57300	LOCAL COMM STABILIZ SHARE	530,017.64	250,000.00	250,000.00	274,647.23	0.00	(24,647.23)	109.86
271-0080-57500	RENAISSANCE ZONE REIMB	0.00	17,000.00	17,000.00	0.00	0.00	17,000.00	0.00
494-0080-57300	LOCAL COMM STABILIZ SHARE	4,907,998.00	4,200,000.00	4,200,000.00	5,124,608.15	0.00	(924,608.15)	122.01
495-0080-57300	LOCAL COMM STABILIZ SHARE	1,207.69	4,000.00	4,000.00	0.00	0.00	4,000.00	0.00
592-0080-56900	SAW GRANT	212,114.10	0.00	0.00	54,021.87	0.00	(54,021.87)	100.00
Net STATE GRANTS		49,223,469.11	48,257,943.00	53,260,704.03	37,365,384.66	0.00	15,895,319.37	70.16
CONTRIB FROM LOCAL UNITS								
101-0080-58100	REIMB CENTER LINE COURT	525,324.46	375,000.00	375,000.00	545,390.13	0.00	(170,390.13)	145.44
208-0080-58105	PLACEMAKING GRANT - MACOMB COU	0.00	0.00	20,000.00	20,000.00	0.00	0.00	100.00
Net CONTRIB FROM LOCAL UNITS		525,324.46	375,000.00	395,000.00	565,390.13	0.00	(170,390.13)	143.14
FINES & FORFEITS								
101-0080-63200	PROBATION FEES	180,492.92	250,000.00	250,000.00	152,462.88	0.00	97,537.12	60.99
101-0080-65800	DISTRICT COURT FINES&FEES	3,228,296.67	4,098,982.00	4,098,982.00	2,500,984.31	0.00	1,597,997.69	61.01
101-0080-65802	DRUG COURT REVENUE	32,345.00	50,000.00	50,000.00	25,430.00	0.00	24,570.00	50.86
101-0080-65804	CIVIL FEES/DRUG TREATMENT	59,091.00	0.00	0.00	41,643.00	0.00	(41,643.00)	100.00
101-0080-65805	PROPERTY MAINTENANCE FINE	275,462.00	150,000.00	150,000.00	198,855.00	0.00	(48,855.00)	132.57
260-0080-66000	VICE CRIME CONFISCATIONS	28,290.35	59,000.00	59,000.00	51,822.78	0.00	7,177.22	87.84
261-0080-66100	FED DRUG FORFEITURES JUSTICE	378,852.76	150,000.00	150,000.00	413,481.93	0.00	(263,481.93)	275.65
261-0080-66101	FED DRUG FORFEITURES TREASURY	47,844.70	0.00	0.00	0.00	0.00	0.00	0.00
261-0080-66102	LOCAL DRUG FORFEITURES	535,226.84	375,000.00	375,000.00	325,067.96	0.00	49,932.04	86.68
271-0080-65600	LIBRARY - PENAL FINES	91,246.84	117,000.00	117,000.00	0.00	0.00	117,000.00	0.00
271-0080-65700	LIBRARY FINES	12,304.45	25,000.00	25,000.00	9,194.75	0.00	15,805.25	36.78
271-0080-65900	LOST BOOK REVENUE	8,393.39	11,000.00	11,000.00	9,207.38	0.00	1,792.62	83.70
410-0080-65803	COURT BLDG RENOVATION FEE	546,292.37	500,000.00	500,000.00	365,494.74	0.00	134,505.26	73.10
Net FINES & FORFEITS		5,424,139.29	5,785,982.00	5,785,982.00	4,093,644.73	0.00	1,692,337.27	70.75
INTEREST AND RENTS								
101-0080-66500	INTEREST ON INVESTMENTS	1,890,430.05	400,000.00	400,000.00	3,749,804.31	0.00	(3,349,804.31)	937.45
101-0080-66700	COURT BUILDING RENTAL	250,000.00	250,000.00	250,000.00	250,000.00	0.00	0.00	100.00
202-0080-66500	INTEREST ON INVESTMENTS	223,931.37	18,000.00	18,000.00	539,696.19	0.00	(521,696.19)	2,998.31
203-0080-66500	INTEREST ON INVESTMENTS	103,602.78	12,000.00	12,000.00	215,727.48	0.00	(203,727.48)	1,797.73
204-0080-66500	INTEREST ON INVESTMENTS	368,542.98	15,000.00	15,000.00	470,225.34	0.00	(455,225.34)	3,134.84
208-0080-66500	INTEREST ON INVESTMENTS	99,840.47	43,000.00	43,000.00	99,523.38	0.00	(56,523.38)	231.45
226-0080-66500	INTEREST ON INVESTMENTS	214,060.27	80,000.00	80,000.00	312,468.21	0.00	(232,468.21)	390.59
226-0080-66800	TRANS STATION ROYALTIES	176,965.36	145,000.00	145,000.00	75,372.17	0.00	69,627.83	51.98
230-0080-66500	INTEREST ON INVESTMENTS	87,811.98	66,000.00	66,000.00	102,110.62	0.00	(36,110.62)	154.71
250-0080-66500	INTEREST ON INVESTMENTS	81,020.23	65,000.00	65,000.00	75,124.49	0.00	(10,124.49)	115.58
250-0080-66810	CABLE TV FRANCHISE FEES	1,707,103.40	1,840,066.00	1,840,066.00	892,766.07	0.00	947,299.93	48.52
259-0080-66500	INTEREST ON INVESTMENTS	20,209.85	0.00	0.00	31,295.18	0.00	(31,295.18)	100.00
260-0080-66500	INTEREST ON INVESTMENTS	15,822.95	1,000.00	1,000.00	17,261.32	0.00	(16,261.32)	1,726.13
261-0080-66500	INTEREST ON INVESTMENTS	72,181.45	7,500.00	7,500.00	69,569.76	0.00	(62,069.76)	927.60
262-0080-66500	INTEREST ON INVESTMENTS	1,390.35	250.00	250.00	2,619.52	0.00	(2,369.52)	1,047.81

REVENUE AND EXPENDITURE REPORT

PERIOD ENDING 04/30/2024

% Fiscal Year Completed: 83.33

GL NUMBER	DESCRIPTION	END BALANCE	2023-24		YTD BALANCE	ENCUMBERED	UNENCUMBERED	% BDGT
		06/30/2023	ORIGINAL	2023-24	04/30/2024			
		NORM (ABNORM)	BUDGET	AMENDED BUDGET	NORM (ABNORM)	YEAR-TO-DATE	BALANCE	USED
271-0080-66500	INTEREST ON INVESTMENTS	205,101.40	15,000.00	15,000.00	252,455.18	0.00	(237,455.18)	1,683.03
273-0080-66500	INTEREST EARNED	0.00	0.00	0.00	32.72	0.00	(32.72)	100.00
277-0080-66500	INTEREST EARNED	8,135.96	0.00	0.00	3,279.33	0.00	(3,279.33)	100.00
281-0080-66500	INTEREST EARNED	27.38	0.00	0.00	76.72	0.00	(76.72)	100.00
385-0080-66500	INTEREST ON INVESTMENTS	2,924.93	500.00	500.00	3,035.17	0.00	(2,535.17)	607.03
410-0080-66500	INTEREST ON INVESTMENTS	400,269.46	15,000.00	15,000.00	438,230.41	0.00	(423,230.41)	2,921.54
433-0080-66500	INTEREST ON INVESTMENTS	13,661.05	0.00	0.00	29,144.02	0.00	(29,144.02)	100.00
434-0080-66500	INTEREST ON INVESTMENTS	114,330.08	0.00	0.00	111,460.69	0.00	(111,460.69)	100.00
435-0080-66500	INTEREST ON INVESTMENTS	101.76	0.00	0.00	0.00	0.00	0.00	0.00
436-0080-66500	INTEREST ON INVESTMENTS	0.04	0.00	0.00	0.00	0.00	0.00	0.00
437-0080-66500	INTEREST ON INVESTMENTS	38,563.71	0.00	0.00	121,437.03	0.00	(121,437.03)	100.00
438-0080-66500	INTEREST ON INVESTMENTS	0.00	0.00	0.00	630,600.61	0.00	(630,600.61)	100.00
492-0080-66500	INTEREST ON INVESTMENTS	8,289.59	0.00	0.00	9,262.70	0.00	(9,262.70)	100.00
493-0080-66500	INTEREST ON INVESTMENTS	127,040.95	0.00	0.00	952,833.81	0.00	(952,833.81)	100.00
494-0080-66500	INTEREST ON INVESTMENTS	709,526.05	75,000.00	75,000.00	(381,951.34)	0.00	456,951.34	(509.27)
495-0080-66500	INTEREST ON INVESTMENTS	662.73	2,500.00	2,500.00	736.84	0.00	1,763.16	29.47
536-0080-66500	INTEREST ON INVESTMENTS	0.00	1,500.00	1,500.00	0.00	0.00	1,500.00	0.00
536-0080-66701	RENTAL REV - ONE BEDROOM	441,433.00	453,794.00	453,794.00	390,719.00	0.00	63,075.00	86.10
536-0080-66702	RENTAL REV - TWO BEDROOM	36,567.00	38,645.00	38,645.00	35,501.00	0.00	3,144.00	91.86
536-0080-66703	RENTAL REV - EFF ROOMS	93,490.00	92,316.00	92,316.00	80,031.00	0.00	12,285.00	86.69
537-0080-66500	INTEREST ON INVESTMENTS	0.00	3,000.00	3,000.00	0.00	0.00	3,000.00	0.00
537-0080-66704	RENTAL REVENUES	1,653,370.96	1,717,525.00	1,717,525.00	1,422,970.00	0.00	294,555.00	82.85
592-0080-66500	INTEREST ON INVESTMENTS	1,028,335.98	168,040.00	168,040.00	1,403,809.91	0.00	(1,235,769.91)	835.40
Net INTEREST AND RENTS		10,194,745.52	5,525,636.00	5,525,636.00	12,407,228.84	0.00	(6,881,592.84)	224.54
OTHER REVENUE								
101-0080-66801	LEASE PROCEEDS	30,063.81	0.00	0.00	112,742.54	0.00	(112,742.54)	100.00
101-0080-67300	SALE OF EQUIPMENT	55,850.00	50,000.00	50,000.00	83,440.00	0.00	(33,440.00)	166.88
101-0080-67350	SALE OF PROPERTY	1,213.00	850,000.00	850,000.00	12.00	0.00	849,988.00	0.00
101-0080-67700	ADMINISTRATIVE FEES	5,620,641.37	5,834,800.00	5,834,800.00	4,862,360.00	0.00	972,440.00	83.33
101-0080-67701	FLEET MAINTENANCE FEES	769,926.00	790,010.00	790,010.00	658,350.00	0.00	131,660.00	83.33
101-0080-67802	EQUIP RENTALS/SERVICE REIMB -	252,031.54	453,000.00	453,000.00	239,957.28	0.00	213,042.72	52.97
101-0080-67803	EQUIP RENTALS - LOCAL ST	882,200.93	1,033,000.00	1,033,000.00	848,044.19	0.00	184,955.81	82.10
101-0080-67804	SALT DOME RENTAL REVENUE	5,000.00	5,000.00	5,000.00	5,000.00	0.00	0.00	100.00
101-0080-67900	MISCELLANEOUS REVENUE	39,386.29	250,000.00	250,000.00	38,622.45	0.00	211,377.55	15.45
101-0080-67907	DONATIONS	0.00	5,000.00	5,000.00	3,000.00	0.00	2,000.00	60.00
101-0080-67913	TELECOM LEASES	35,895.96	35,000.00	35,000.00	76,040.67	0.00	(41,040.67)	217.26
101-0080-67920	EMG RUBBISH / BOARDINGS	3,920.86	0.00	0.00	1,435.46	0.00	(1,435.46)	100.00
101-0080-67921	SNOW REMOVALS	1,087.50	0.00	0.00	250.00	0.00	(250.00)	100.00
101-0080-67922	RODENT BAITING	188.00	0.00	0.00	84.00	0.00	(84.00)	100.00
101-0080-67923	BLIGHT BUSTERS	81,627.50	0.00	0.00	60,962.50	0.00	(60,962.50)	100.00
101-0080-68500	NATIONAL OPIOID SETTLEMENT	758,608.40	0.00	0.00	192,514.92	0.00	(192,514.92)	100.00
202-0080-67900	MISCELLANEOUS REVENUE	45,038.45	0.00	0.00	0.00	0.00	0.00	0.00
202-0080-67904	WINTER MAINT (DEQUINDRE)	12,500.00	12,500.00	12,500.00	0.00	0.00	12,500.00	0.00
203-0080-67905	P.A. 48 - R.O.W. TELECOM	582,991.08	550,000.00	550,000.00	0.00	0.00	550,000.00	0.00
208-0080-66801	LEASE PROCEEDS	0.00	55,000.00	0.00	0.00	0.00	0.00	0.00
208-0080-67300	SALE OF EQUIPMENT	8,800.00	0.00	0.00	7,600.00	0.00	(7,600.00)	100.00
208-0080-67900	MISCELLANEOUS REVENUE	1,059.57	7,500.00	7,500.00	1.50	0.00	7,498.50	0.02
208-0080-67913	TELECOM LEASES	68,136.08	0.00	55,000.00	68,136.08	0.00	(13,136.08)	123.88
226-0080-66801	LEASE PROCEEDS	52,310.60	52,305.00	52,305.00	26,607.36	0.00	25,697.64	50.87
226-0080-67300	SALE OF EQUIPMENT	0.00	0.00	0.00	69,400.00	0.00	(69,400.00)	100.00
226-0080-67901	MISCELLANEOUS - REIMBURS	172,508.82	80,000.00	80,000.00	55,180.26	0.00	24,819.74	68.98
226-0080-67910	SANITATION RECYCLING REV	38,347.89	35,000.00	35,000.00	36,539.68	0.00	(1,539.68)	104.40
250-0080-66801	LEASE PROCEEDS	0.00	0.00	0.00	13,147.50	0.00	(13,147.50)	100.00
250-0080-67900	MISCELLANEOUS REVENUE	17,782.50	200.00	200.00	13.50	0.00	186.50	6.75
271-0080-67300	SALE OF EQUIPMENT	4,100.00	0.00	0.00	0.00	0.00	0.00	0.00
271-0080-67350	SALE OF PROPERTY	0.00	0.00	0.00	94,922.61	0.00	(94,922.61)	100.00
271-0080-67900	MISCELLANEOUS REVENUE	20,789.81	10,500.00	10,500.00	112,459.18	0.00	(101,959.18)	1,071.04

REVENUE AND EXPENDITURE REPORT

PERIOD ENDING 04/30/2024

% Fiscal Year Completed: 83.33

GL NUMBER	DESCRIPTION	END BALANCE	2023-24		YTD BALANCE	ENCUMBERED	UNENCUMBERED	% BDGT
		06/30/2023	ORIGINAL	2023-24	04/30/2024			
		NORM (ABNORM)	BUDGET	AMENDED BUDGET	NORM (ABNORM)	YEAR-TO-DATE	BALANCE	USED
271-0080-67907	DONATIONS	95.20	0.00	0.00	121.14	0.00	(121.14)	100.00
492-0080-67900	MISCELLANEOUS REVENUE	80,669.98	0.00	0.00	750.00	0.00	(750.00)	100.00
494-0080-67900	MISCELLANEOUS REVENUE	50.00	25,000.00	25,000.00	0.00	0.00	25,000.00	0.00
536-0080-67737	ADMIN EXPENSE - JOS COACH	454,181.00	479,377.00	479,377.00	397,430.00	0.00	81,947.00	82.91
536-0080-67900	MISCELLANEOUS REVENUE	23,600.70	20,000.00	20,000.00	18,251.73	0.00	1,748.27	91.26
537-0080-67900	MISCELLANEOUS REVENUE	15,514.56	17,500.00	17,500.00	14,367.88	0.00	3,132.12	82.10
900-0000-98511	CAPITAL OUTLAY - GENERAL GOV	927,487.53	0.00	0.00	0.00	0.00	0.00	0.00
900-0000-98512	CAPITAL OUTLAY - PUBLIC SAFETY	5,023,274.97	0.00	0.00	0.00	0.00	0.00	0.00
900-0000-98513	CAPITAL OUTLAY - CITY DEV	2,716,660.36	0.00	0.00	0.00	0.00	0.00	0.00
900-0000-98514	CAPITAL OUTLAY - SANITATION	338,923.63	0.00	0.00	0.00	0.00	0.00	0.00
900-0000-98515	CAPITAL OUTLAY - REC & CULTURE	3,573,146.12	0.00	0.00	0.00	0.00	0.00	0.00
900-0000-98516	CAPITAL OUTLAY - HIGHWAYS & ST	28,095,152.01	0.00	0.00	0.00	0.00	0.00	0.00
Net OTHER REVENUE		50,810,762.02	10,650,692.00	10,650,692.00	8,097,744.43	0.00	2,552,947.57	76.03

OTHER FINANCING SOURCES

101-0080-69901	FUND BALANCE APPROPRIATED	0.00	15,494,339.00	25,391,218.00	0.00	0.00	25,391,218.00	0.00
202-0080-69501	TRANSFER FROM GEN FUND	0.00	76,906.00	76,906.00	0.00	0.00	76,906.00	0.00
202-0080-69901	FUND BALANCE APPROPRIATED	0.00	350,312.00	4,325,491.00	0.00	0.00	4,325,491.00	0.00
203-0080-69501	TRANSFER FROM GEN FUND	0.00	86,906.00	86,906.00	0.00	0.00	86,906.00	0.00
203-0080-69901	FUND BALANCE APPROPRIATED	0.00	1,009,002.00	3,269,805.00	0.00	0.00	3,269,805.00	0.00
203-0080-69902	TRFR FROM MAJOR ST FUND	2,500,000.00	1,000,000.00	1,000,000.00	1,000,000.00	0.00	0.00	100.00
204-0080-69901	FUND BALANCE APPROPRIATED	0.00	0.00	7,072,951.00	0.00	0.00	7,072,951.00	0.00
208-0080-69901	FUND BALANCE APPROPRIATED	0.00	404,130.00	1,302,156.00	0.00	0.00	1,302,156.00	0.00
226-0080-69901	FUND BALANCE APPROPRIATED	0.00	1,208,436.00	1,675,236.00	0.00	0.00	1,675,236.00	0.00
230-0080-69901	FUND BALANCE APPROPRIATED	0.00	0.00	14,600.00	0.00	0.00	14,600.00	0.00
250-0080-69901	FUND BALANCE APPROPRIATED	0.00	605,748.00	684,420.00	0.00	0.00	684,420.00	0.00
259-0080-69501	TRANSFER FROM GEN FUND	123,769.06	0.00	123,769.06	123,769.06	0.00	0.00	100.00
259-0080-69901	FUND BALANCE APPROPRIATED	0.00	0.00	408,077.40	0.00	0.00	408,077.40	0.00
261-0080-69901	FUND BALANCE APPROPRIATED	0.00	7,500.00	1,155,694.00	0.00	0.00	1,155,694.00	0.00
262-0080-69901	FUND BALANCE APPROPRIATED	0.00	2,750.00	2,750.00	0.00	0.00	2,750.00	0.00
271-0080-69901	FUND BALANCE APPROPRIATED	0.00	0.00	199,196.00	0.00	0.00	199,196.00	0.00
356-0080-69902	TRFR FROM MAJOR ST FUND	0.00	1,608,420.00	1,671,013.00	401,637.49	0.00	1,269,375.51	24.04
357-0080-69902	TRFR FROM MAJOR ST FUND	922,054.17	923,750.00	923,750.00	279,625.00	0.00	644,125.00	30.27
358-0080-69902	TRFR FROM MAJOR ST FUND	322,124.75	311,161.00	311,161.00	311,018.79	0.00	142.21	99.95
359-0080-69902	TRFR FROM MAJOR ST FUND	191,643.88	182,750.00	182,750.00	182,748.68	0.00	1.32	100.00
360-0080-69902	TRFR FROM MAJOR ST FUND	1,105,017.50	1,101,318.00	1,101,318.00	145,908.75	0.00	955,409.25	13.25
361-0080-69902	TRFR FROM MAJOR ST FUND	1,258,700.00	1,256,700.00	1,256,700.00	293,600.00	0.00	963,100.00	23.36
381-0080-69802	TRANS FROM S/A FUND 802	36,562.38	0.00	0.00	35,720.08	0.00	(35,720.08)	100.00
385-0080-69901	FUND BALANCE APPROPRIATED	0.00	25,000.00	25,000.00	0.00	0.00	25,000.00	0.00
386-0080-69208	TRANSFER FROM P&R FUND	245,713.01	0.00	0.00	250,336.82	0.00	(250,336.82)	100.00
386-0080-69271	TRANSFER FROM LIBRARY	105,305.58	0.00	0.00	107,287.21	0.00	(107,287.21)	100.00
386-0080-69950	TRFR FROM CABLE TV FUND	351,018.62	0.00	0.00	357,624.06	0.00	(357,624.06)	100.00
391-0080-69494	TRANS FROM DDA	1,548,089.00	1,458,059.00	1,458,059.00	1,458,059.00	0.00	0.00	100.00
392-0080-69494	TRANS FROM DDA	0.00	1,659,959.00	1,659,959.00	558,958.32	0.00	1,101,000.68	33.67
393-0080-69494	TRANS FROM DDA	3,342,600.00	3,220,525.00	3,220,525.00	3,220,525.00	0.00	0.00	100.00
394-0080-69494	TRANS FROM DDA	1,234,050.00	1,430,425.00	1,430,425.00	1,430,425.00	0.00	0.00	100.00
410-0080-69901	FUND BALANCE APPROPRIATED	0.00	0.00	306,932.00	0.00	0.00	306,932.00	0.00
437-0080-69603	BOND PROCEEDS	13,309,214.65	0.00	0.00	0.00	0.00	0.00	0.00
438-0080-69603	BOND PROCEEDS	0.00	0.00	0.00	23,534,655.35	0.00	(23,534,655.35)	100.00
493-0080-69603	BOND PROCEEDS	22,921,908.35	0.00	0.00	0.00	0.00	0.00	0.00
494-0080-69901	FUND BALANCE APPROPRIATED	0.00	4,917,323.00	8,473,023.00	0.00	0.00	8,473,023.00	0.00
495-0080-69901	FUND BALANCE APPROPRIATED	0.00	298,375.00	298,375.00	0.00	0.00	298,375.00	0.00
536-0080-69901	FUND BALANCE APPROPRIATED	0.00	280,425.00	391,925.00	0.00	0.00	391,925.00	0.00
537-0080-69901	FUND BALANCE APPROPRIATED	0.00	343,301.00	604,301.00	0.00	0.00	604,301.00	0.00
592-0080-67601	TRANSFER FROM RET EARNING	0.00	10,289,110.00	13,750,187.00	0.00	0.00	13,750,187.00	0.00
801-0080-69501	TRANSFER FROM GEN FUND	500,000.00	0.00	0.00	0.00	0.00	0.00	0.00
Net OTHER FINANCING SOURCES		50,017,770.95	49,552,630.00	83,854,578.46	33,691,898.61	0.00	50,162,679.85	40.18

REVENUE AND EXPENDITURE REPORT

PERIOD ENDING 04/30/2024

% Fiscal Year Completed: 83.33

GL NUMBER	DESCRIPTION	END BALANCE	2023-24		YTD BALANCE	ENCUMBERED	UNENCUMBERED	% BDGT
		06/30/2023	ORIGINAL	2023-24	04/30/2024			
		NORM (ABNORM)	BUDGET	AMENDED BUDGET	NORM (ABNORM)	YEAR-TO-DATE	BALANCE	USED
PERSONNEL SERVICES								
101-1101-70200	ELECTED OFFICIALS	219,884.00	219,884.00	219,884.00	183,738.40	0.00	36,145.60	83.56
101-1101-70600	PERMANENT EMPLOYEES	163,186.08	273,075.00	273,075.00	133,508.61	0.00	139,566.39	48.89
101-1101-70900	OVERTIME	2,406.70	7,839.00	7,839.00	968.10	0.00	6,870.90	12.35
101-1101-71303	CLEAN/CLOTHING ALLOWANCE	650.00	1,400.00	1,400.00	700.00	0.00	700.00	50.00
101-1101-71500	SOCIAL SECURITY	29,976.38	39,454.00	39,454.00	25,113.64	0.00	14,340.36	63.65
101-1101-71900	EMPLOYEE INSURANCES	131,335.97	198,744.00	198,744.00	127,102.72	0.00	71,641.28	63.95
101-1101-71904	RETIREE HEALTH INSURANCE	68,511.00	68,511.00	68,511.00	57,090.00	0.00	11,421.00	83.33
101-1101-71905	H.S.A. EXPENSE	7,401.51	10,319.00	10,319.00	6,517.53	0.00	3,801.47	63.16
101-1101-71906	SUPPL LIFE INSURANCE EXP	726.00	776.00	776.00	310.00	0.00	466.00	39.95
101-1101-72100	LONGEVITY	3,136.86	5,917.00	5,917.00	5,917.00	0.00	0.24	100.00
101-1101-72101	BONUS/SICK REDEMPTION	7,239.00	7,457.00	7,457.00	7,456.20	0.00	0.80	99.99
101-1101-72200	RETIREMENT FUND	124,436.00	114,558.00	114,558.00	95,470.00	0.00	19,088.00	83.34
101-1101-72201	DEFINED CONTRIBUTION EXP	40,148.15	51,565.00	51,565.00	33,809.45	0.00	17,755.55	65.57
101-1136-70200	ELECTED OFFICIALS	156,692.68	183,612.00	183,612.00	147,020.27	0.00	36,591.73	80.07
101-1136-70600	PERMANENT EMPLOYEES	2,706,869.78	3,108,514.00	3,108,514.00	2,346,425.99	0.00	762,088.01	75.48
101-1136-70703	CLERICAL CO-OP	225,649.28	269,520.00	269,520.00	188,822.46	0.00	80,697.54	70.06
101-1136-70716	TEMPORARY - DRUG COURT	2,937.00	0.00	149,589.00	3,625.00	0.00	145,964.00	2.42
101-1136-70900	OVERTIME	2,574.18	5,025.00	30,025.00	516.38	0.00	29,508.62	1.72
101-1136-71303	CLEAN/CLOTHING ALLOWANCE	5,725.00	16,100.00	16,100.00	6,275.00	0.00	9,825.00	38.98
101-1136-71500	SOCIAL SECURITY	235,002.02	273,043.00	284,636.00	202,282.05	0.00	82,353.95	71.07
101-1136-71900	EMPLOYEE INSURANCES	725,595.23	887,144.00	887,144.00	667,901.21	0.00	219,242.79	75.29
101-1136-71904	RETIREE HEALTH INSURANCE	639,408.00	639,408.00	639,408.00	532,840.00	0.00	106,568.00	83.33
101-1136-71905	H.S.A. EXPENSE	37,576.06	44,528.00	44,528.00	34,059.69	0.00	10,468.31	76.49
101-1136-71906	SUPPL LIFE INSURANCE EXP	3,543.94	4,464.00	4,464.00	3,157.58	0.00	1,306.42	70.73
101-1136-72100	LONGEVITY	77,768.36	87,069.00	87,069.00	64,722.82	0.00	22,346.18	74.34
101-1136-72101	BONUS/SICK REDEMPTION	52,264.42	82,366.00	82,366.00	44,251.18	0.00	38,114.82	53.73
101-1136-72200	RETIREMENT FUND	684,398.00	630,058.00	630,058.00	525,050.00	0.00	105,008.00	83.33
101-1136-72201	DEFINED CONTRIBUTION EXP	281,922.29	318,577.00	318,577.00	245,863.77	0.00	72,713.23	77.18
101-1171-70200	ELECTED OFFICIALS	126,125.24	126,133.00	126,133.00	100,996.95	0.00	25,136.05	80.07
101-1171-70600	PERMANENT EMPLOYEES	206,855.55	348,495.00	348,495.00	177,397.56	0.00	171,097.44	50.90
101-1171-70703	CLERICAL CO-OP	28,080.82	35,000.00	35,000.00	16,080.27	0.00	18,919.73	45.94
101-1171-70900	OVERTIME	0.00	0.00	4,055.00	4,367.00	0.00	(312.00)	107.69
101-1171-71303	CLEAN/CLOTHING ALLOWANCE	900.00	1,750.00	1,750.00	1,116.67	0.00	633.33	63.81
101-1171-71500	SOCIAL SECURITY	28,829.08	40,172.00	40,172.00	23,451.72	0.00	16,720.28	58.38
101-1171-71900	EMPLOYEE INSURANCES	41,296.90	108,541.00	108,541.00	28,240.98	0.00	80,300.02	26.02
101-1171-71904	RETIREE HEALTH INSURANCE	22,837.00	22,837.00	22,837.00	19,030.00	0.00	3,807.00	83.33
101-1171-71905	H.S.A. EXPENSE	4,512.52	7,281.00	7,281.00	4,891.29	0.00	2,389.71	67.18
101-1171-71906	SUPPL LIFE INSURANCE EXP	0.00	0.00	300.00	162.56	0.00	137.44	54.19
101-1171-72100	LONGEVITY	5,976.64	6,054.00	6,054.00	3,614.72	0.00	2,439.28	59.71
101-1171-72101	BONUS/SICK REDEMPTION	7,401.00	7,625.00	7,625.00	2,774.84	0.00	4,850.16	36.39
101-1171-72201	DEFINED CONTRIBUTION EXP	35,175.86	49,009.00	49,009.00	29,289.13	0.00	19,719.87	59.76
101-1209-70300	APPOINTED OFFICIAL	123,559.75	127,274.00	127,274.00	110,224.46	0.00	17,049.54	86.60
101-1209-70600	PERMANENT EMPLOYEES	738,973.84	850,008.00	850,008.00	631,214.57	0.00	218,793.43	74.26
101-1209-70703	CLERICAL CO-OP	15,390.00	50,000.00	50,000.00	8,786.50	0.00	41,213.50	17.57
101-1209-70900	OVERTIME	21,149.15	25,000.00	25,000.00	23,449.39	0.00	1,550.61	93.80
101-1209-71303	CLEAN/CLOTHING ALLOWANCE	3,800.00	4,200.00	4,200.00	4,375.00	0.00	(175.00)	104.17
101-1209-71500	SOCIAL SECURITY	70,644.25	84,065.00	84,065.00	61,259.29	0.00	22,805.71	72.87
101-1209-71900	EMPLOYEE INSURANCES	188,715.29	249,083.00	249,083.00	175,448.23	0.00	73,634.77	70.44
101-1209-71904	RETIREE HEALTH INSURANCE	137,022.00	137,022.00	137,022.00	114,190.00	0.00	22,832.00	83.34
101-1209-71905	H.S.A. EXPENSE	16,083.33	18,764.00	18,764.00	13,878.66	0.00	4,885.34	73.96
101-1209-71906	SUPPL LIFE INSURANCE EXP	1,739.46	1,932.00	1,932.00	1,339.20	0.00	592.80	69.32
101-1209-72100	LONGEVITY	12,786.16	16,392.00	16,392.00	9,496.51	0.00	6,895.49	57.93
101-1209-72101	BONUS/SICK REDEMPTION	17,537.02	25,833.00	25,833.00	19,832.93	0.00	6,000.07	76.77
101-1209-72200	RETIREMENT FUND	311,090.00	286,390.00	286,390.00	238,660.00	0.00	47,730.00	83.33
101-1209-72201	DEFINED CONTRIBUTION EXP	80,416.15	93,801.00	93,801.00	69,394.33	0.00	24,406.67	73.98
101-1210-70300	APPOINTED OFFICIAL	134,609.97	138,656.00	138,656.00	121,715.05	0.00	16,940.95	87.78
101-1210-70601	ASSISTANT ATTORNEYS	515,077.41	553,962.00	553,962.00	361,343.73	0.00	192,618.27	65.23

REVENUE AND EXPENDITURE REPORT

PERIOD ENDING 04/30/2024

% Fiscal Year Completed: 83.33

GL NUMBER	DESCRIPTION	END BALANCE	2023-24		YTD BALANCE	ENCUMBERED	UNENCUMBERED	% BDGT
		06/30/2023	ORIGINAL	2023-24	04/30/2024			
		NORM (ABNORM)	BUDGET	AMENDED BUDGET	NORM (ABNORM)	YEAR-TO-DATE	BALANCE	USED
101-1210-70602	CLERICAL	279,787.17	291,036.00	291,036.00	228,626.04	0.00	62,409.96	78.56
101-1210-70701	LAW CLERKS	35,069.53	50,000.00	50,000.00	34,414.96	0.00	15,585.04	68.83
101-1210-70703	CLERICAL CO-OP	25,330.20	100,000.00	100,000.00	41,264.54	0.00	58,735.46	41.26
101-1210-70900	OVERTIME	0.00	7,500.00	7,500.00	0.00	0.00	7,500.00	0.00
101-1210-71303	CLEAN/CLOTHING ALLOWANCE	3,000.00	3,500.00	3,500.00	3,733.33	0.00	(233.33)	106.67
101-1210-71500	SOCIAL SECURITY	78,385.44	91,846.00	91,846.00	63,422.71	0.00	28,423.29	69.05
101-1210-71900	EMPLOYEE INSURANCES	199,397.80	219,123.00	219,123.00	162,323.60	0.00	56,799.40	74.08
101-1210-71904	RETIREE HEALTH INSURANCE	91,348.00	91,348.00	91,348.00	76,120.00	0.00	15,228.00	83.33
101-1210-71905	H.S.A. EXPENSE	11,458.90	15,168.00	15,168.00	10,023.95	0.00	5,144.05	66.09
101-1210-71906	SUPPL LIFE INSURANCE EXP	2,591.44	2,334.00	2,334.00	1,748.64	0.00	585.36	74.92
101-1210-72100	LONGEVITY	18,579.26	23,753.00	23,753.00	20,638.95	0.00	3,114.05	86.89
101-1210-72101	BONUS/SICK REDEMPTION	25,115.83	32,049.00	32,049.00	21,163.78	0.00	10,885.22	66.04
101-1210-72200	RETIREMENT FUND	124,436.00	114,558.00	114,558.00	95,470.00	0.00	19,088.00	83.34
101-1210-72201	DEFINED CONTRIBUTION EXP	88,398.81	95,226.00	95,226.00	68,897.29	0.00	26,328.71	72.35
101-1215-70200	ELECTED OFFICIALS	93,280.40	93,286.00	93,286.00	74,695.80	0.00	18,590.20	80.07
101-1215-70600	PERMANENT EMPLOYEES	373,058.15	426,694.00	426,694.00	324,434.51	0.00	102,259.49	76.03
101-1215-70703	CLERICAL CO-OP	88,236.24	221,600.00	281,754.00	102,482.90	0.00	179,271.10	36.37
101-1215-70900	OVERTIME	24,953.18	92,900.00	105,500.00	46,091.85	0.00	59,408.15	43.69
101-1215-71303	CLEAN/CLOTHING ALLOWANCE	2,156.69	2,450.00	2,450.00	2,100.00	0.00	350.00	85.71
101-1215-71500	SOCIAL SECURITY	45,937.04	66,312.00	76,616.00	47,628.45	0.00	28,987.55	62.17
101-1215-71900	EMPLOYEE INSURANCES	94,534.23	138,844.00	139,020.00	89,214.94	0.00	49,805.06	64.17
101-1215-71904	RETIREE HEALTH INSURANCE	68,511.00	68,511.00	68,511.00	57,090.00	0.00	11,421.00	83.33
101-1215-71905	H.S.A. EXPENSE	8,520.21	11,041.00	11,293.00	7,931.31	0.00	3,361.69	70.23
101-1215-71906	SUPPL LIFE INSURANCE EXP	782.00	1,190.00	1,190.00	869.88	0.00	320.12	73.10
101-1215-72100	LONGEVITY	8,638.00	10,163.00	10,163.00	10,160.82	0.00	2.18	99.98
101-1215-72101	BONUS/SICK REDEMPTION	8,352.36	19,620.00	19,620.00	10,703.16	0.00	8,916.84	54.55
101-1215-72200	RETIREMENT FUND	62,217.00	57,278.00	57,278.00	47,730.00	0.00	9,548.00	83.33
101-1215-72201	DEFINED CONTRIBUTION EXP	56,610.97	69,177.00	70,437.00	50,894.99	0.00	19,542.01	72.26
101-1220-70600	PERMANENT EMPLOYEES	542,344.95	620,149.00	620,149.00	422,750.15	0.00	197,398.85	68.17
101-1220-70703	CLERICAL CO-OP	34,074.81	75,000.00	75,000.00	0.00	0.00	75,000.00	0.00
101-1220-70900	OVERTIME	10,739.45	25,000.00	25,000.00	12,222.70	0.00	12,777.30	48.89
101-1220-71303	CLEAN/CLOTHING ALLOWANCE	2,350.00	2,800.00	2,800.00	2,800.00	0.00	0.00	100.00
101-1220-71500	SOCIAL SECURITY	47,341.45	58,237.00	58,237.00	35,568.43	0.00	22,668.57	61.08
101-1220-71900	EMPLOYEE INSURANCES	91,647.56	158,592.00	158,592.00	87,669.28	0.00	70,922.72	55.28
101-1220-71904	RETIREE HEALTH INSURANCE	91,348.00	91,348.00	91,348.00	76,120.00	0.00	15,228.00	83.33
101-1220-71905	H.S.A. EXPENSE	9,586.20	11,182.00	11,182.00	8,439.19	0.00	2,742.81	75.47
101-1220-71906	SUPPL LIFE INSURANCE EXP	343.76	600.00	600.00	329.70	0.00	270.30	54.95
101-1220-72100	LONGEVITY	11,837.62	14,138.00	14,138.00	9,987.24	0.00	4,150.76	70.64
101-1220-72101	BONUS/SICK REDEMPTION	21,401.17	24,056.00	24,056.00	19,233.07	0.00	4,822.93	79.95
101-1220-72200	RETIREMENT FUND	124,436.00	114,558.00	114,558.00	95,470.00	0.00	19,088.00	83.34
101-1220-72201	DEFINED CONTRIBUTION EXP	59,674.78	68,617.00	68,617.00	47,847.21	0.00	20,769.79	69.73
101-1220-72501	FEES & PER DIEM	4,450.00	4,000.00	4,000.00	1,050.00	0.00	2,950.00	26.25
101-1221-72501	FEES & PER DIEM	1,250.00	2,000.00	2,000.00	550.00	0.00	1,450.00	27.50
101-1223-70300	APPOINTED OFFICIAL	127,533.65	135,085.00	135,085.00	108,165.64	0.00	26,919.36	80.07
101-1223-70600	PERMANENT EMPLOYEES	876,452.09	1,075,738.00	1,075,738.00	788,054.02	0.00	287,683.98	73.26
101-1223-70703	CLERICAL CO-OP	0.00	40,000.00	40,000.00	0.00	0.00	40,000.00	0.00
101-1223-70900	OVERTIME	10,450.05	20,000.00	20,000.00	15,474.50	0.00	4,525.50	77.37
101-1223-71303	CLEAN/CLOTHING ALLOWANCE	3,800.00	4,550.00	4,550.00	3,850.00	0.00	700.00	84.62
101-1223-71500	SOCIAL SECURITY	84,210.08	104,195.00	104,195.00	75,301.83	0.00	28,893.17	72.27
101-1223-71900	EMPLOYEE INSURANCES	187,435.80	266,106.00	266,106.00	205,691.78	0.00	60,414.22	77.30
101-1223-71904	RETIREE HEALTH INSURANCE	114,185.00	114,185.00	114,185.00	95,150.00	0.00	19,035.00	83.33
101-1223-71905	H.S.A. EXPENSE	9,903.06	16,172.00	16,172.00	9,584.16	0.00	6,587.84	59.26
101-1223-71906	SUPPL LIFE INSURANCE EXP	3,217.92	4,430.00	4,430.00	2,860.42	0.00	1,569.58	64.57
101-1223-72100	LONGEVITY	27,155.55	34,548.00	34,548.00	20,865.08	0.00	13,682.92	60.39
101-1223-72101	BONUS/SICK REDEMPTION	48,800.77	51,919.00	51,919.00	42,011.51	0.00	9,907.49	80.92
101-1223-72200	RETIREMENT FUND	124,436.00	114,558.00	114,558.00	95,470.00	0.00	19,088.00	83.34
101-1223-72201	DEFINED CONTRIBUTION EXP	84,716.50	106,952.00	106,952.00	76,872.26	0.00	30,079.74	71.88
101-1237-70600	PERMANENT EMPLOYEES	156,946.07	169,016.00	169,016.00	135,313.81	0.00	33,702.19	80.06

REVENUE AND EXPENDITURE REPORT

PERIOD ENDING 04/30/2024

% Fiscal Year Completed: 83.33

GL NUMBER	DESCRIPTION	END BALANCE	2023-24		YTD BALANCE	ENCUMBERED	UNENCUMBERED	% BDGT
		06/30/2023	ORIGINAL	2023-24	04/30/2024			
		NORM (ABNORM)	BUDGET	AMENDED BUDGET	NORM (ABNORM)	YEAR-TO-DATE	BALANCE	USED
101-1237-70700	TEMPORARY EMPLOYEES	2,467.50	10,000.00	10,000.00	2,485.00	0.00	7,515.00	24.85
101-1237-70900	OVERTIME	9,043.27	10,000.00	10,000.00	8,334.83	0.00	1,665.17	83.35
101-1237-71302	EDUCATION ALLOWANCE	1,400.00	1,500.00	1,500.00	1,500.00	0.00	0.00	100.00
101-1237-71303	CLEAN/CLOTHING ALLOWANCE	650.00	700.00	700.00	700.00	0.00	0.00	100.00
101-1237-71500	SOCIAL SECURITY	13,662.46	15,745.00	15,745.00	12,218.12	0.00	3,526.88	77.60
101-1237-71900	EMPLOYEE INSURANCES	31,098.35	43,498.00	43,498.00	30,772.70	0.00	12,725.30	70.75
101-1237-71902	RETIREE INSURANCES	7,745,001.08	8,500,000.00	8,500,000.00	6,871,745.99	0.00	1,628,254.01	80.84
101-1237-71904	RETIREE HEALTH INSURANCE	45,674.00	45,674.00	45,674.00	38,060.00	0.00	7,614.00	83.33
101-1237-71905	H.S.A. EXPENSE	2,074.43	2,265.00	2,265.00	1,841.96	0.00	423.04	81.32
101-1237-71906	SUPPL LIFE INSURANCE EXP	372.00	480.00	480.00	310.00	0.00	170.00	64.58
101-1237-72100	LONGEVITY	6,800.00	6,800.00	6,800.00	6,800.00	0.00	0.00	100.00
101-1237-72101	BONUS/SICK REDEMPTION	4,736.18	7,771.00	7,771.00	7,196.68	0.00	574.32	92.61
101-1237-72201	DEFINED CONTRIBUTION EXP	17,938.28	19,579.00	19,579.00	15,984.64	0.00	3,594.36	81.64
101-1238-70600	PERMANENT EMPLOYEES	214,732.34	246,522.00	246,522.00	197,394.23	0.00	49,127.77	80.07
101-1238-70700	TEMPORARY EMPLOYEES	9,053.50	20,000.00	20,000.00	0.00	0.00	20,000.00	0.00
101-1238-70900	OVERTIME	13,938.25	5,200.00	17,200.00	12,327.08	0.00	4,872.92	71.67
101-1238-71302	EDUCATION ALLOWANCE	1,500.00	2,500.00	2,500.00	2,500.00	0.00	0.00	100.00
101-1238-71303	CLEAN/CLOTHING ALLOWANCE	650.00	1,050.00	1,050.00	1,050.00	0.00	0.00	100.00
101-1238-71500	SOCIAL SECURITY	19,181.10	22,450.00	22,450.00	17,014.13	0.00	5,435.87	75.79
101-1238-71900	EMPLOYEE INSURANCES	54,432.99	65,158.00	65,158.00	55,102.03	0.00	10,055.97	84.57
101-1238-71902	RETIREE INSURANCES	9,232,624.77	10,500,000.00	10,500,000.00	8,790,029.54	0.00	1,709,970.46	83.71
101-1238-71904	RETIREE HEALTH INSURANCE	45,674.00	45,674.00	45,674.00	38,060.00	0.00	7,614.00	83.33
101-1238-71905	H.S.A. EXPENSE	1,031.23	1,670.00	1,670.00	1,272.92	0.00	397.08	76.22
101-1238-71906	SUPPL LIFE INSURANCE EXP	514.20	756.00	756.00	457.60	0.00	298.40	60.53
101-1238-72100	LONGEVITY	10,200.00	6,800.00	10,200.00	10,200.00	0.00	0.00	100.00
101-1238-72101	BONUS/SICK REDEMPTION	5,746.10	11,335.00	11,335.00	4,509.48	0.00	6,825.52	39.78
101-1238-72200	RETIREMENT FUND	62,217.00	57,278.00	57,278.00	47,730.00	0.00	9,548.00	83.33
101-1238-72201	DEFINED CONTRIBUTION EXP	34,437.26	37,099.00	37,099.00	31,014.84	0.00	6,084.16	83.60
101-1253-70200	ELECTED OFFICIALS	93,280.40	93,286.00	93,286.00	74,695.80	0.00	18,590.20	80.07
101-1253-70600	PERMANENT EMPLOYEES	514,142.60	615,467.00	615,467.00	457,243.21	0.00	158,223.79	74.29
101-1253-70703	CLERICAL CO-OP	8,652.00	21,000.00	21,000.00	12,232.00	0.00	8,768.00	58.25
101-1253-70900	OVERTIME	442.23	4,000.00	4,000.00	226.33	0.00	3,773.67	5.66
101-1253-71303	CLEAN/CLOTHING ALLOWANCE	2,350.00	2,800.00	2,800.00	3,004.17	0.00	(204.17)	107.29
101-1253-71500	SOCIAL SECURITY	49,534.98	59,541.00	59,541.00	44,220.30	0.00	15,320.70	74.27
101-1253-71900	EMPLOYEE INSURANCES	149,055.63	194,531.00	194,531.00	153,660.26	0.00	40,870.74	78.99
101-1253-71904	RETIREE HEALTH INSURANCE	114,185.00	114,185.00	114,185.00	95,150.00	0.00	19,035.00	83.33
101-1253-71905	H.S.A. EXPENSE	5,706.46	7,540.00	7,540.00	5,311.86	0.00	2,228.14	70.45
101-1253-71906	SUPPL LIFE INSURANCE EXP	383.04	596.00	596.00	339.60	0.00	256.40	56.98
101-1253-72100	LONGEVITY	16,154.68	19,632.00	19,632.00	15,016.67	0.00	4,615.33	76.49
101-1253-72101	BONUS/SICK REDEMPTION	18,461.40	22,007.00	22,007.00	20,111.18	0.00	1,895.82	91.39
101-1253-72200	RETIREMENT FUND	124,436.00	114,558.00	114,558.00	95,470.00	0.00	19,088.00	83.34
101-1253-72201	DEFINED CONTRIBUTION EXP	63,507.38	84,652.00	84,652.00	56,259.91	0.00	28,392.09	66.46
101-1258-70600	PERMANENT EMPLOYEES	327,346.99	445,133.00	445,133.00	296,054.53	0.00	149,078.47	66.51
101-1258-70700	TEMPORARY EMPLOYEES	0.00	7,500.00	7,500.00	0.00	0.00	7,500.00	0.00
101-1258-70900	OVERTIME	16,763.04	15,000.00	15,000.00	5,157.50	0.00	9,842.50	34.38
101-1258-71303	CLEAN/CLOTHING ALLOWANCE	1,050.00	1,750.00	1,750.00	1,400.00	0.00	350.00	80.00
101-1258-71500	SOCIAL SECURITY	28,214.60	38,481.00	38,481.00	24,915.88	0.00	13,565.12	64.75
101-1258-71900	EMPLOYEE INSURANCES	64,014.46	108,962.00	108,962.00	64,640.54	0.00	44,321.46	59.32
101-1258-71904	RETIREE HEALTH INSURANCE	68,511.00	68,511.00	68,511.00	57,090.00	0.00	11,421.00	83.33
101-1258-71905	H.S.A. EXPENSE	3,564.98	5,859.00	5,859.00	3,266.13	0.00	2,592.87	55.75
101-1258-71906	SUPPL LIFE INSURANCE EXP	541.44	840.00	840.00	461.00	0.00	379.00	54.88
101-1258-72100	LONGEVITY	11,552.00	13,094.00	13,094.00	11,652.30	0.00	1,441.70	88.99
101-1258-72101	BONUS/SICK REDEMPTION	16,458.04	20,467.00	20,467.00	13,692.36	0.00	6,774.64	66.90
101-1258-72201	DEFINED CONTRIBUTION EXP	42,787.62	55,556.00	55,556.00	37,364.31	0.00	18,191.69	67.26
101-1265-70501	SUPERINTENDENT	92,885.20	105,410.00	105,410.00	80,722.20	0.00	24,687.80	76.58
101-1265-70600	PERMANENT EMPLOYEES	774,952.27	1,004,631.00	1,004,631.00	633,771.00	0.00	370,860.00	63.08
101-1265-70900	OVERTIME	4,323.88	36,000.00	36,000.00	4,712.05	0.00	31,287.95	13.09
101-1265-71303	CLEAN/CLOTHING ALLOWANCE	4,591.11	7,000.00	7,000.00	6,125.00	0.00	875.00	87.50

REVENUE AND EXPENDITURE REPORT

PERIOD ENDING 04/30/2024

% Fiscal Year Completed: 83.33

GL NUMBER	DESCRIPTION	END BALANCE	2023-24		YTD BALANCE	ENCUMBERED	UNENCUMBERED	% BDGT
		06/30/2023	ORIGINAL	2023-24	04/30/2024			
		NORM (ABNORM)	BUDGET	AMENDED BUDGET	NORM (ABNORM)	YEAR-TO-DATE	BALANCE	USED
101-1265-71500	SOCIAL SECURITY	68,160.08	92,253.00	92,253.00	56,210.57	0.00	36,042.43	60.93
101-1265-71900	EMPLOYEE INSURANCES	243,625.59	468,961.00	468,961.00	254,952.32	0.00	214,008.68	54.37
101-1265-71904	RETIREE HEALTH INSURANCE	159,859.00	159,859.00	159,859.00	133,220.00	0.00	26,639.00	83.34
101-1265-71905	H.S.A. EXPENSE	12,896.49	18,470.00	18,470.00	11,057.26	0.00	7,412.74	59.87
101-1265-71906	SUPPL LIFE INSURANCE EXP	2,943.60	5,088.00	5,088.00	2,393.51	0.00	2,694.49	47.04
101-1265-72100	LONGEVITY	14,710.24	26,805.00	26,805.00	9,311.60	0.00	17,493.40	34.74
101-1265-72101	BONUS/SICK REDEMPTION	11,220.84	25,705.00	25,705.00	11,131.57	0.00	14,573.43	43.31
101-1265-72200	RETIREMENT FUND	373,308.00	343,668.00	343,668.00	286,390.00	0.00	57,278.00	83.33
101-1265-72201	DEFINED CONTRIBUTION EXP	87,829.00	127,091.00	127,091.00	72,663.66	0.00	54,427.34	57.17
101-1294-71302	EDUCATION ALLOWANCE	63,033.33	70,000.00	70,000.00	63,916.66	0.00	6,083.34	91.31
101-1301-70300	APPOINTED OFFICIAL	138,515.43	142,680.00	154,680.00	126,300.83	0.00	28,379.17	81.65
101-1301-70602	CLERICAL	1,999,304.90	2,888,992.00	2,879,950.00	1,819,549.83	0.00	1,060,400.17	63.18
101-1301-70605	POLICEMEN	19,376,646.41	21,883,563.00	21,202,063.00	16,558,780.45	0.00	4,643,282.55	78.10
101-1301-70703	CLERICAL CO-OP	108,307.30	96,824.00	105,866.00	68,614.13	0.00	37,251.87	64.81
101-1301-70707	CROSSING GUARDS	246,889.80	330,000.00	330,000.00	216,670.50	0.00	113,329.50	65.66
101-1301-70902	OVERTIME - CLERICAL	192,801.84	151,913.00	151,913.00	89,518.68	0.00	62,394.32	58.93
101-1301-70905	OVERTIME - POLICEMEN	1,395,127.60	1,213,795.00	1,863,795.00	1,406,923.07	0.00	456,871.93	75.49
101-1301-71000	SHIFT PREMIUM	307,679.76	325,000.00	325,000.00	269,172.49	0.00	55,827.51	82.82
101-1301-71301	GUN ALLOWANCE	213,167.03	229,900.00	229,900.00	5,676.59	0.00	224,223.41	2.47
101-1301-71302	EDUCATION ALLOWANCE	54,066.67	59,300.00	59,300.00	56,066.67	0.00	3,233.33	94.55
101-1301-71303	CLEAN/CLOTHING ALLOWANCE	119,017.01	160,450.00	160,450.00	142,936.31	0.00	17,513.69	89.08
101-1301-71500	SOCIAL SECURITY	541,867.60	652,342.00	652,342.00	458,854.19	0.00	193,487.81	70.34
101-1301-71700	HOLIDAY PAY	1,224,681.27	1,450,123.00	1,450,123.00	572,765.66	0.00	877,357.34	39.50
101-1301-71900	EMPLOYEE INSURANCES	4,886,486.03	6,643,673.00	6,636,673.00	4,483,611.70	0.00	2,153,061.30	67.56
101-1301-71904	RETIREE HEALTH INSURANCE	6,318,738.00	5,170,473.00	5,170,473.00	4,308,730.00	0.00	861,743.00	83.33
101-1301-71905	H.S.A. EXPENSE	359,528.29	455,865.00	455,865.00	319,933.54	0.00	135,931.46	70.18
101-1301-71906	SUPPL LIFE INSURANCE EXP	10,653.31	11,922.00	11,922.00	9,369.38	0.00	2,552.62	78.59
101-1301-72100	LONGEVITY	312,311.69	355,996.00	355,996.00	294,057.64	0.00	61,938.36	82.60
101-1301-72101	BONUS/SICK REDEMPTION	25,152.29	47,548.00	47,548.00	26,284.00	0.00	21,264.00	55.28
101-1301-72200	RETIREMENT FUND	9,654,958.00	9,837,412.00	9,837,412.00	8,197,840.00	0.00	1,639,572.00	83.33
101-1301-72201	DEFINED CONTRIBUTION EXP	211,199.60	299,869.00	299,869.00	186,425.47	0.00	113,443.53	62.17
101-1336-70300	APPOINTED OFFICIAL	133,558.40	137,572.00	137,572.00	110,157.81	0.00	27,414.19	80.07
101-1336-70602	CLERICAL	197,937.02	276,253.00	276,253.00	205,034.98	0.00	71,218.02	74.22
101-1336-70603	FIREMEN	11,241,222.71	12,687,538.00	12,687,538.00	9,579,235.11	0.00	3,108,302.89	75.50
101-1336-70606	FIREFIGHTER CADETS	241,831.07	293,400.00	293,400.00	91,907.93	0.00	201,492.07	31.33
101-1336-70703	CLERICAL CO-OP	0.00	35,000.00	35,000.00	6,261.75	0.00	28,738.25	17.89
101-1336-70902	OVERTIME - CLERICAL	2,328.87	5,000.00	5,000.00	525.00	0.00	4,475.00	10.50
101-1336-70903	OVERTIME - FIRE FIGHTERS	2,029,527.73	1,000,000.00	1,000,000.00	1,451,847.78	0.00	(451,847.78)	145.18
101-1336-70906	OVERTIME - FF CADETS	0.00	5,000.00	5,000.00	0.00	0.00	5,000.00	0.00
101-1336-71000	SHIFT PREMIUM	66,876.93	150,000.00	150,000.00	40,601.11	0.00	109,398.89	27.07
101-1336-71302	EDUCATION ALLOWANCE	23,850.01	23,950.00	23,950.00	19,275.00	0.00	4,675.00	80.48
101-1336-71303	CLEAN/CLOTHING ALLOWANCE	10,491.32	17,450.00	17,450.00	11,097.63	0.00	6,352.37	63.60
101-1336-71304	FOOD ALLOWANCE	121,085.07	129,000.00	129,000.00	60,860.91	0.00	68,139.09	47.18
101-1336-71306	AEMT LICENSE ALLOWANCE	27,249.97	17,500.00	17,500.00	7,833.33	0.00	9,666.67	44.76
101-1336-71500	SOCIAL SECURITY	247,073.13	279,155.00	279,155.00	199,572.39	0.00	79,582.61	71.49
101-1336-71700	HOLIDAY PAY	697,829.78	835,375.00	835,375.00	680,059.26	0.00	155,315.74	81.41
101-1336-71900	EMPLOYEE INSURANCES	2,594,189.87	3,421,764.00	3,421,764.00	2,484,280.91	0.00	937,483.09	72.60
101-1336-71904	RETIREE HEALTH INSURANCE	3,680,568.00	2,949,803.00	2,949,803.00	2,458,170.00	0.00	491,633.00	83.33
101-1336-71905	H.S.A. EXPENSE	206,128.55	255,861.00	255,861.00	192,385.48	0.00	63,475.52	75.19
101-1336-71906	SUPPL LIFE INSURANCE EXP	4,125.77	46,777.00	46,777.00	3,320.66	0.00	43,456.34	7.10
101-1336-72100	LONGEVITY	163,252.80	173,502.00	173,502.00	122,601.83	0.00	50,900.17	70.66
101-1336-72101	BONUS/SICK REDEMPTION	10,368.15	18,473.00	18,473.00	2,955.51	0.00	15,517.49	16.00
101-1336-72200	RETIREMENT FUND	5,063,388.00	5,233,072.00	5,233,072.00	4,360,890.00	0.00	872,182.00	83.33
101-1336-72201	DEFINED CONTRIBUTION EXP	41,084.21	55,156.00	55,156.00	37,927.46	0.00	17,228.54	68.76
101-1371-70500	SUPERVISORY	106,056.58	124,630.00	124,630.00	66,543.57	0.00	58,086.43	53.39
101-1371-70602	CLERICAL	192,729.91	354,924.00	354,924.00	87,482.48	0.00	267,441.52	24.65
101-1371-70609	INSPECTORS	1,249,913.91	1,600,211.00	1,600,211.00	1,147,722.12	0.00	452,488.88	71.72
101-1371-70703	CLERICAL CO-OP	49,623.25	95,000.00	95,000.00	70,074.25	0.00	24,925.75	73.76

REVENUE AND EXPENDITURE REPORT

PERIOD ENDING 04/30/2024

% Fiscal Year Completed: 83.33

GL NUMBER	DESCRIPTION	END BALANCE	2023-24		YTD BALANCE	ENCUMBERED	UNENCUMBERED	% BDGT
		06/30/2023	ORIGINAL	2023-24	04/30/2024			
		NORM (ABNORM)	BUDGET	AMENDED BUDGET	NORM (ABNORM)	YEAR-TO-DATE	BALANCE	USED
101-1371-70705	TEMPORARY - INSPECTION	88,581.60	175,000.00	175,000.00	11,059.05	0.00	163,940.95	6.32
101-1371-70902	OVERTIME - CLERICAL	2,489.25	5,000.00	5,000.00	2,612.16	0.00	2,387.84	52.24
101-1371-70909	OVERTIME - INSPECTORS	75,388.24	70,000.00	70,000.00	68,742.59	0.00	1,257.41	98.20
101-1371-71303	CLEAN/CLOTHING ALLOWANCE	6,600.00	9,450.00	9,450.00	7,554.17	0.00	1,895.83	79.94
101-1371-71500	SOCIAL SECURITY	137,398.41	194,175.00	194,175.00	115,134.92	0.00	79,040.08	59.29
101-1371-71900	EMPLOYEE INSURANCES	394,924.96	679,521.00	679,521.00	373,680.31	0.00	305,840.69	54.99
101-1371-71904	RETIREE HEALTH INSURANCE	251,196.00	251,196.00	251,196.00	209,330.00	0.00	41,866.00	83.33
101-1371-71905	H.S.A. EXPENSE	29,964.28	41,689.00	41,689.00	25,811.60	0.00	15,877.40	61.91
101-1371-71906	SUPPL LIFE INSURANCE EXP	3,392.48	4,000.00	4,000.00	3,553.89	0.00	446.11	88.85
101-1371-72100	LONGEVITY	27,250.58	34,023.00	34,023.00	22,611.52	0.00	11,411.48	66.46
101-1371-72101	BONUS/SICK REDEMPTION	32,311.01	69,589.00	69,589.00	39,466.01	0.00	30,122.99	56.71
101-1371-72200	RETIREMENT FUND	248,872.00	229,116.00	229,116.00	190,930.00	0.00	38,186.00	83.33
101-1371-72201	DEFINED CONTRIBUTION EXP	173,022.40	238,316.00	238,316.00	147,770.49	0.00	90,545.51	62.01
101-1371-72501	FEES & PER DIEM	11,273.32	15,000.00	15,000.00	10,190.69	0.00	4,809.31	67.94
101-1400-70300	APPOINTED OFFICIAL	110,290.77	113,606.00	113,606.00	90,966.43	0.00	22,639.57	80.07
101-1400-70600	PERMANENT EMPLOYEES	236,928.27	447,026.00	447,026.00	235,987.44	0.00	211,038.56	52.79
101-1400-70712	TEMPORARY - PLANNING AIDE	23,760.04	35,360.00	31,360.00	0.00	0.00	31,360.00	0.00
101-1400-70900	OVERTIME	4,370.30	5,000.00	9,000.00	6,460.24	0.00	2,539.76	71.78
101-1400-71303	CLEAN/CLOTHING ALLOWANCE	1,350.00	2,450.00	2,450.00	1,750.00	0.00	700.00	71.43
101-1400-71500	SOCIAL SECURITY	30,297.37	48,463.00	48,463.00	26,894.99	0.00	21,568.01	55.50
101-1400-71900	EMPLOYEE INSURANCES	60,906.28	183,422.00	183,422.00	65,070.88	0.00	118,351.12	35.48
101-1400-71904	RETIREE HEALTH INSURANCE	45,674.00	45,674.00	45,674.00	38,060.00	0.00	7,614.00	83.33
101-1400-71905	H.S.A. EXPENSE	5,102.04	9,512.00	9,512.00	5,153.30	0.00	4,358.70	54.18
101-1400-71906	SUPPL LIFE INSURANCE EXP	2,083.92	2,480.00	2,480.00	1,844.60	0.00	635.40	74.38
101-1400-72100	LONGEVITY	5,221.76	8,810.00	8,810.00	7,168.46	0.00	1,641.54	81.37
101-1400-72101	BONUS/SICK REDEMPTION	12,783.93	21,124.00	21,124.00	8,040.31	0.00	13,083.69	38.06
101-1400-72201	DEFINED CONTRIBUTION EXP	43,594.19	65,934.00	65,934.00	40,198.21	0.00	25,735.79	60.97
101-1400-72500	MEETING ALLOWANCE	12,000.00	19,275.00	19,275.00	8,775.00	0.00	10,500.00	45.53
101-1401-70600	PERMANENT EMPLOYEES	77,448.73	175,382.00	175,382.00	106,521.03	0.00	68,860.97	60.74
101-1401-70700	TEMPORARY EMPLOYEES	0.00	35,000.00	35,000.00	4,415.00	0.00	30,585.00	12.61
101-1401-71303	CLEAN/CLOTHING ALLOWANCE	350.00	1,050.00	1,050.00	700.00	0.00	350.00	66.67
101-1401-71500	SOCIAL SECURITY	6,419.97	16,707.00	16,707.00	8,926.51	0.00	7,780.49	53.43
101-1401-71900	EMPLOYEE INSURANCES	4,520.49	64,338.00	64,338.00	6,062.47	0.00	58,275.53	9.42
101-1401-71905	H.S.A. EXPENSE	1,722.02	3,669.00	3,669.00	2,302.42	0.00	1,366.58	62.75
101-1401-71906	SUPPL LIFE INSURANCE EXP	57.60	360.00	360.00	56.28	0.00	303.72	15.63
101-1401-72100	LONGEVITY	2,964.64	3,400.00	3,400.00	3,400.00	0.00	0.00	100.00
101-1401-72101	BONUS/SICK REDEMPTION	1,140.26	3,524.00	3,524.00	0.00	0.00	3,524.00	0.00
101-1401-72201	DEFINED CONTRIBUTION EXP	8,610.32	18,337.00	18,337.00	11,512.08	0.00	6,824.92	62.78
101-1410-72500	MEETING ALLOWANCE	12,975.00	16,200.00	16,200.00	7,125.00	0.00	9,075.00	43.98
101-1421-70300	APPOINTED OFFICIAL	129,791.39	133,693.00	133,693.00	110,572.21	0.00	23,120.79	82.71
101-1421-70600	PERMANENT EMPLOYEES	140,609.88	227,297.00	227,297.00	116,014.59	0.00	111,282.41	51.04
101-1421-70900	OVERTIME	0.00	0.00	5,465.00	5,463.20	0.00	1.80	99.97
101-1421-71303	CLEAN/CLOTHING ALLOWANCE	1,000.00	1,400.00	1,400.00	1,225.00	0.00	175.00	87.50
101-1421-71500	SOCIAL SECURITY	21,608.26	29,316.00	29,316.00	19,619.63	0.00	9,696.37	66.92
101-1421-71900	EMPLOYEE INSURANCES	57,041.23	90,106.00	90,106.00	52,400.92	0.00	37,705.08	58.15
101-1421-71904	RETIREE HEALTH INSURANCE	22,837.00	22,837.00	22,837.00	19,030.00	0.00	3,807.00	83.33
101-1421-71905	H.S.A. EXPENSE	3,966.73	5,796.00	5,796.00	2,864.63	0.00	2,931.37	49.42
101-1421-71906	SUPPL LIFE INSURANCE EXP	780.00	1,068.00	1,068.00	886.51	0.00	181.49	83.01
101-1421-72100	LONGEVITY	7,938.30	7,973.00	7,973.00	7,972.44	0.00	0.56	99.99
101-1421-72101	BONUS/SICK REDEMPTION	5,967.48	12,794.00	12,794.00	9,834.31	0.00	2,959.69	76.87
101-1421-72201	DEFINED CONTRIBUTION EXP	28,530.78	38,317.00	38,317.00	25,732.72	0.00	12,584.28	67.16
101-1422-70600	PERMANENT EMPLOYEES	254,237.49	414,457.00	414,457.00	249,863.20	0.00	164,593.80	60.29
101-1422-70609	INSPECTORS	156,097.27	202,587.00	202,587.00	89,426.04	0.00	113,160.96	44.14
101-1422-70700	TEMPORARY EMPLOYEES	35,805.60	35,000.00	35,000.00	31,836.00	0.00	3,164.00	90.96
101-1422-70705	TEMPORARY - INSPECTION	801,605.90	1,265,000.00	1,265,000.00	539,952.00	0.00	725,048.00	42.68
101-1422-70909	OVERTIME - INSPECTORS	25,657.40	250,000.00	250,000.00	18,151.01	0.00	231,848.99	7.26
101-1422-71303	CLEAN/CLOTHING ALLOWANCE	2,604.95	4,200.00	4,200.00	3,150.00	0.00	1,050.00	75.00
101-1422-71500	SOCIAL SECURITY	97,250.54	167,021.00	167,021.00	71,420.35	0.00	95,600.65	42.76

REVENUE AND EXPENDITURE REPORT

PERIOD ENDING 04/30/2024

% Fiscal Year Completed: 83.33

GL NUMBER	DESCRIPTION	END BALANCE	2023-24		YTD BALANCE	ENCUMBERED	UNENCUMBERED	% BDGT
		06/30/2023	ORIGINAL	2023-24	04/30/2024			
		NORM (ABNORM)	BUDGET	AMENDED BUDGET	NORM (ABNORM)	YEAR-TO-DATE	BALANCE	USED
101-1422-71900	EMPLOYEE INSURANCES	183,157.56	399,955.00	399,955.00	145,670.36	0.00	254,284.64	36.42
101-1422-71905	H.S.A. EXPENSE	8,643.06	17,669.00	17,669.00	7,335.04	0.00	10,333.96	41.51
101-1422-71906	SUPPL LIFE INSURANCE EXP	1,092.86	1,578.00	1,578.00	680.77	0.00	897.23	43.14
101-1422-72100	LONGEVITY	957.16	3,624.00	3,624.00	2,401.44	0.00	1,222.56	66.26
101-1422-72101	BONUS/SICK REDEMPTION	5,899.21	8,360.00	8,360.00	8,075.82	0.00	284.18	96.60
101-1422-72201	DEFINED CONTRIBUTION EXP	43,735.64	88,324.00	88,324.00	36,675.09	0.00	51,648.91	41.52
101-1426-70605	POLICEMEN	109,604.80	104,401.00	104,401.00	83,595.05	0.00	20,805.95	80.07
101-1426-70905	OVERTIME - POLICEMEN	4,998.67	8,000.00	8,000.00	5,742.41	0.00	2,257.59	71.78
101-1426-71000	SHIFT PREMIUM	0.00	100.00	100.00	48.00	0.00	52.00	48.00
101-1426-71301	GUN ALLOWANCE	950.00	950.00	950.00	0.00	0.00	950.00	0.00
101-1426-71302	EDUCATION ALLOWANCE	0.00	600.00	600.00	600.00	0.00	0.00	100.00
101-1426-71303	CLEAN/CLOTHING ALLOWANCE	202.21	600.00	600.00	600.00	0.00	0.00	100.00
101-1426-71500	SOCIAL SECURITY	1,780.19	1,831.00	1,831.00	1,515.25	0.00	315.75	82.76
101-1426-71700	HOLIDAY PAY	6,203.81	6,400.00	6,400.00	2,788.21	0.00	3,611.79	43.57
101-1426-71900	EMPLOYEE INSURANCES	25,054.01	23,910.00	30,910.00	23,599.93	0.00	7,310.07	76.35
101-1426-71904	RETIREE HEALTH INSURANCE	47,503.00	38,013.00	38,013.00	31,680.00	0.00	6,333.00	83.34
101-1426-71906	SUPPL LIFE INSURANCE EXP	0.00	240.00	240.00	0.00	0.00	240.00	0.00
101-1426-72100	LONGEVITY	2,720.00	2,720.00	2,720.00	2,720.00	0.00	0.00	100.00
101-1426-72101	BONUS/SICK REDEMPTION	0.00	2,400.00	2,400.00	0.00	0.00	2,400.00	0.00
101-1426-72200	RETIREMENT FUND	38,359.00	37,648.00	37,648.00	31,370.00	0.00	6,278.00	83.32
101-1430-70600	PERMANENT EMPLOYEES	157,231.13	197,784.00	195,284.00	145,851.21	0.00	49,432.79	74.69
101-1430-70900	OVERTIME	1,328.27	7,000.00	7,000.00	0.00	0.00	7,000.00	0.00
101-1430-71303	CLEAN/CLOTHING ALLOWANCE	(0.83)	1,050.00	1,140.00	1,140.00	0.00	0.00	100.00
101-1430-71500	SOCIAL SECURITY	12,083.67	16,315.00	16,315.00	11,025.05	0.00	5,289.95	67.58
101-1430-71900	EMPLOYEE INSURANCES	34,215.72	65,752.00	65,752.00	34,913.37	0.00	30,838.63	53.10
101-1430-71904	RETIREE HEALTH INSURANCE	45,672.00	45,672.00	45,672.00	38,060.00	0.00	7,612.00	83.33
101-1430-71905	H.S.A. EXPENSE	2,895.92	4,266.00	4,266.00	2,966.23	0.00	1,299.77	69.53
101-1430-71906	SUPPL LIFE INSURANCE EXP	165.88	240.00	240.00	140.00	0.00	100.00	58.33
101-1430-72100	LONGEVITY	1,507.75	1,314.00	1,314.00	1,313.42	0.00	0.58	99.96
101-1430-72101	BONUS/SICK REDEMPTION	0.00	6,062.00	6,062.00	0.00	0.00	6,062.00	0.00
101-1430-72200	RETIREMENT FUND	62,217.00	57,278.00	57,278.00	47,730.00	0.00	9,548.00	83.33
101-1430-72201	DEFINED CONTRIBUTION EXP	16,120.60	21,322.00	21,322.00	14,830.48	0.00	6,491.52	69.55
101-1441-71900	EMPLOYEE INSURANCES	0.00	0.00	0.00	98,880.31	0.00	(98,880.31)	100.00
101-1442-70604	MECHANICS	941,940.89	1,171,616.00	1,171,616.00	744,051.18	0.00	427,564.82	63.51
101-1442-70700	TEMPORARY EMPLOYEES	27,426.00	40,000.00	40,000.00	20,375.60	0.00	19,624.40	50.94
101-1442-70900	OVERTIME	249.12	5,500.00	5,500.00	108.68	0.00	5,391.32	1.98
101-1442-70904	OVERTIME - MECHANICS	40,174.92	100,000.00	100,000.00	27,350.95	0.00	72,649.05	27.35
101-1442-71303	CLEAN/CLOTHING ALLOWANCE	4,386.18	5,600.00	5,600.00	4,200.00	0.00	1,400.00	75.00
101-1442-71500	SOCIAL SECURITY	79,274.58	106,086.00	106,086.00	61,978.73	0.00	44,107.27	58.42
101-1442-71900	EMPLOYEE INSURANCES	208,964.55	387,487.00	387,487.00	182,386.12	0.00	205,100.88	47.07
101-1442-71904	RETIREE HEALTH INSURANCE	182,696.00	182,696.00	182,696.00	152,250.00	0.00	30,446.00	83.34
101-1442-71905	H.S.A. EXPENSE	12,082.99	18,173.00	18,173.00	11,115.01	0.00	7,057.99	61.16
101-1442-71906	SUPPL LIFE INSURANCE EXP	991.56	1,180.00	1,180.00	871.84	0.00	308.16	73.88
101-1442-72100	LONGEVITY	27,513.57	38,220.00	38,220.00	17,818.20	0.00	20,401.80	46.62
101-1442-72101	BONUS/SICK REDEMPTION	15,944.21	25,621.00	25,621.00	12,931.55	0.00	12,689.45	50.47
101-1442-72200	RETIREMENT FUND	186,654.00	171,837.00	171,837.00	143,200.00	0.00	28,637.00	83.33
101-1442-72201	DEFINED CONTRIBUTION EXP	96,665.64	130,954.00	130,954.00	84,910.55	0.00	46,043.45	64.84
101-1447-70602	CLERICAL	59,896.21	63,165.00	63,165.00	50,394.68	0.00	12,770.32	79.78
101-1447-70608	ENGINEERS & INSPECTORS	312,122.46	401,947.00	401,947.00	311,005.82	0.00	90,941.18	77.37
101-1447-70705	TEMPORARY - INSPECTION	16,200.00	148,000.00	148,000.00	0.00	0.00	148,000.00	0.00
101-1447-70706	TEMPORARY - ENGINEER	0.00	74,000.00	74,000.00	4,160.00	0.00	69,840.00	5.62
101-1447-70902	OVERTIME - CLERICAL	0.00	500.00	500.00	0.00	0.00	500.00	0.00
101-1447-70908	OVERTIME - ENGINEERING	122,153.30	130,000.00	130,000.00	87,435.22	0.00	42,564.78	67.26
101-1447-71303	CLEAN/CLOTHING ALLOWANCE	1,449.49	2,100.00	2,100.00	2,100.00	0.00	0.00	100.00
101-1447-71500	SOCIAL SECURITY	39,563.32	64,683.00	64,683.00	35,481.99	0.00	29,201.01	54.86
101-1447-71900	EMPLOYEE INSURANCES	98,525.39	177,767.00	177,767.00	116,555.46	0.00	61,211.54	65.57
101-1447-71904	RETIREE HEALTH INSURANCE	68,511.00	68,511.00	68,511.00	57,090.00	0.00	11,421.00	83.33
101-1447-71905	H.S.A. EXPENSE	7,428.20	10,442.00	10,442.00	7,274.01	0.00	3,167.99	69.66

REVENUE AND EXPENDITURE REPORT

PERIOD ENDING 04/30/2024

% Fiscal Year Completed: 83.33

GL NUMBER	DESCRIPTION	END BALANCE	2023-24		YTD BALANCE	ENCUMBERED	UNENCUMBERED	% BDGT
		06/30/2023	ORIGINAL	2023-24	04/30/2024			
		NORM (ABNORM)	BUDGET	AMENDED BUDGET	NORM (ABNORM)	YEAR-TO-DATE	BALANCE	USED
101-1447-71906	SUPPL LIFE INSURANCE EXP	1,240.92	1,444.00	1,549.00	1,236.38	0.00	312.62	79.82
101-1447-72100	LONGEVITY	9,553.88	11,283.00	11,283.00	6,800.00	0.00	4,483.00	60.27
101-1447-72101	BONUS/SICK REDEMPTION	3,243.76	14,432.00	14,432.00	6,028.80	0.00	8,403.20	41.77
101-1447-72200	RETIREMENT FUND	124,436.00	114,558.00	114,558.00	95,470.00	0.00	19,088.00	83.34
101-1447-72201	DEFINED CONTRIBUTION EXP	57,495.36	73,914.00	73,914.00	51,829.96	0.00	22,084.04	70.12
101-1793-70700	TEMPORARY EMPLOYEES	3,192.00	0.00	0.00	0.00	0.00	0.00	0.00
101-1793-71500	SOCIAL SECURITY	244.19	0.00	0.00	0.00	0.00	0.00	0.00
101-1793-71900	EMPLOYEE INSURANCES	3.12	0.00	0.00	0.00	0.00	0.00	0.00
202-2463-70600	PERMANENT EMPLOYEES	363,212.91	539,900.00	539,900.00	446,079.11	0.00	93,820.89	82.62
202-2463-70700	TEMPORARY EMPLOYEES	1,593.00	33,750.00	33,750.00	0.00	0.00	33,750.00	0.00
202-2463-70900	OVERTIME	2,870.76	55,081.00	55,081.00	3,504.15	0.00	51,576.85	6.36
202-2463-71302	EDUCATION ALLOWANCE	232.68	882.00	882.00	1,500.00	0.00	(618.00)	170.07
202-2463-71303	CLEAN/CLOTHING ALLOWANCE	6,519.96	2,570.00	2,570.00	8,137.50	0.00	(5,567.50)	316.63
202-2463-71308	CERTIFICATION BONUSES	0.00	823.00	823.00	0.00	0.00	823.00	0.00
202-2463-71500	SOCIAL SECURITY	30,865.73	52,171.00	52,171.00	31,587.30	0.00	20,583.70	60.55
202-2463-71900	EMPLOYEE INSURANCES	103,196.50	192,966.00	192,966.00	91,945.82	0.00	101,020.18	47.65
202-2463-71904	RETIREE HEALTH INSURANCE	123,266.00	127,462.00	127,462.00	106,220.00	0.00	21,242.00	83.33
202-2463-71905	H.S.A. EXPENSE	2,474.48	7,403.00	7,403.00	3,785.72	0.00	3,617.28	51.14
202-2463-71906	SUPPL LIFE INSURANCE EXP	512.79	459.00	459.00	2,231.24	0.00	(1,772.24)	486.11
202-2463-72100	LONGEVITY	14,208.49	24,970.00	24,970.00	40,295.92	0.00	(15,325.92)	161.38
202-2463-72101	BONUS/SICK REDEMPTION	18,975.78	23,752.00	23,752.00	28,867.11	0.00	(5,115.11)	121.54
202-2463-72200	RETIREMENT FUND	194,437.00	185,092.00	185,092.00	154,240.00	0.00	30,852.00	83.33
202-2463-72201	DEFINED CONTRIBUTION EXP	28,136.31	55,127.00	55,127.00	29,964.34	0.00	25,162.66	54.36
202-2474-70600	PERMANENT EMPLOYEES	23,967.42	30,067.00	30,067.00	18,726.69	0.00	11,340.31	62.28
202-2474-70900	OVERTIME	0.00	3,068.00	3,068.00	0.00	0.00	3,068.00	0.00
202-2474-71302	EDUCATION ALLOWANCE	16.17	49.00	49.00	0.00	0.00	49.00	0.00
202-2474-71303	CLEAN/CLOTHING ALLOWANCE	0.00	143.00	143.00	0.00	0.00	143.00	0.00
202-2474-71308	CERTIFICATION BONUSES	0.00	46.00	46.00	0.00	0.00	46.00	0.00
202-2474-71500	SOCIAL SECURITY	1,897.13	2,761.00	2,761.00	2,000.71	0.00	760.29	72.46
202-2474-71900	EMPLOYEE INSURANCES	7,197.82	10,746.00	10,746.00	5,192.06	0.00	5,553.94	48.32
202-2474-71904	RETIREE HEALTH INSURANCE	6,986.00	7,098.00	7,098.00	5,920.00	0.00	1,178.00	83.40
202-2474-71905	H.S.A. EXPENSE	188.98	413.00	413.00	286.50	0.00	126.50	69.37
202-2474-71906	SUPPL LIFE INSURANCE EXP	25.00	26.00	26.00	0.00	0.00	26.00	0.00
202-2474-72100	LONGEVITY	987.72	1,391.00	1,391.00	0.00	0.00	1,391.00	0.00
202-2474-72101	BONUS/SICK REDEMPTION	0.00	1,323.00	1,323.00	0.00	0.00	1,323.00	0.00
202-2474-72200	RETIREMENT FUND	11,019.00	10,308.00	10,308.00	8,590.00	0.00	1,718.00	83.33
202-2474-72201	DEFINED CONTRIBUTION EXP	944.72	3,070.00	3,070.00	1,432.59	0.00	1,637.41	46.66
202-2479-70600	PERMANENT EMPLOYEES	14,846.75	51,423.00	51,423.00	16,058.07	0.00	35,364.93	31.23
202-2479-70900	OVERTIME	42,914.05	5,246.00	5,246.00	17,338.05	0.00	(12,092.05)	330.50
202-2479-71302	EDUCATION ALLOWANCE	24.06	84.00	84.00	0.00	0.00	84.00	0.00
202-2479-71303	CLEAN/CLOTHING ALLOWANCE	0.00	245.00	245.00	0.00	0.00	245.00	0.00
202-2479-71308	CERTIFICATION BONUSES	0.00	78.00	78.00	0.00	0.00	78.00	0.00
202-2479-71500	SOCIAL SECURITY	4,915.59	4,722.00	4,722.00	2,779.32	0.00	1,942.68	58.86
202-2479-71900	EMPLOYEE INSURANCES	10,455.03	18,379.00	18,379.00	7,977.00	0.00	10,402.00	43.40
202-2479-71904	RETIREE HEALTH INSURANCE	15,143.00	12,140.00	12,140.00	10,120.00	0.00	2,020.00	83.36
202-2479-71905	H.S.A. EXPENSE	505.11	705.00	705.00	422.68	0.00	282.32	59.95
202-2479-71906	SUPPL LIFE INSURANCE EXP	53.03	44.00	44.00	0.00	0.00	44.00	0.00
202-2479-72100	LONGEVITY	1,469.37	2,378.00	2,378.00	0.00	0.00	2,378.00	0.00
202-2479-72101	BONUS/SICK REDEMPTION	0.00	2,262.00	2,262.00	0.00	0.00	2,262.00	0.00
202-2479-72200	RETIREMENT FUND	23,885.00	17,629.00	17,629.00	14,690.00	0.00	2,939.00	83.33
202-2479-72201	DEFINED CONTRIBUTION EXP	4,539.50	5,251.00	5,251.00	2,826.53	0.00	2,424.47	53.83
202-2483-70500	SUPERVISORY	53,472.43	103,744.00	103,744.00	45,468.60	0.00	58,275.40	43.83
202-2483-70602	CLERICAL	54,789.77	101,684.00	101,684.00	47,777.18	0.00	53,906.82	46.99
202-2483-70700	TEMPORARY EMPLOYEES	0.00	17,500.00	17,500.00	0.00	0.00	17,500.00	0.00
202-2483-70902	OVERTIME - CLERICAL	801.72	5,000.00	5,000.00	2,284.80	0.00	2,715.20	45.70
202-2483-71303	CLEAN/CLOTHING ALLOWANCE	500.00	875.00	875.00	583.34	0.00	291.66	66.67
202-2483-71500	SOCIAL SECURITY	9,078.48	18,828.00	18,828.00	7,740.90	0.00	11,087.10	41.11
202-2483-71900	EMPLOYEE INSURANCES	23,208.23	40,094.00	40,094.00	15,490.46	0.00	24,603.54	38.64

REVENUE AND EXPENDITURE REPORT

PERIOD ENDING 04/30/2024

% Fiscal Year Completed: 83.33

GL NUMBER	DESCRIPTION	END BALANCE	2023-24		YTD BALANCE	ENCUMBERED	UNENCUMBERED	% BDGT
		06/30/2023	ORIGINAL	2023-24	04/30/2024			
		NORM (ABNORM)	BUDGET	AMENDED BUDGET	NORM (ABNORM)	YEAR-TO-DATE	BALANCE	USED
202-2483-71904	RETIREE HEALTH INSURANCE	22,836.00	22,836.00	22,836.00	19,030.00	0.00	3,806.00	83.33
202-2483-71905	H.S.A. EXPENSE	500.23	2,637.00	2,637.00	474.68	0.00	2,162.32	18.00
202-2483-71906	SUPPL LIFE INSURANCE EXP	260.15	327.00	327.00	200.00	0.00	127.00	61.16
202-2483-72100	LONGEVITY	4,398.36	7,829.00	7,829.00	3,719.99	0.00	4,109.01	47.52
202-2483-72101	BONUS/SICK REDEMPTION	4,827.39	9,445.00	9,445.00	14,369.58	0.00	(4,924.58)	152.14
202-2483-72200	RETIREMENT FUND	31,109.00	28,639.00	28,639.00	23,870.00	0.00	4,769.00	83.35
202-2483-72201	DEFINED CONTRIBUTION EXP	6,195.98	19,669.00	19,669.00	8,503.20	0.00	11,165.80	43.23
203-3463-70600	PERMANENT EMPLOYEES	904,710.44	1,090,993.00	1,090,993.00	764,673.10	0.00	326,319.90	70.09
203-3463-70700	TEMPORARY EMPLOYEES	3,165.66	41,250.00	41,250.00	0.00	0.00	41,250.00	0.00
203-3463-70900	OVERTIME	29,622.50	111,306.00	111,306.00	28,749.65	0.00	82,556.35	25.83
203-3463-71302	EDUCATION ALLOWANCE	564.07	1,781.00	1,781.00	0.00	0.00	1,781.00	0.00
203-3463-71303	CLEAN/CLOTHING ALLOWANCE	0.00	5,195.00	5,195.00	0.00	0.00	5,195.00	0.00
203-3463-71308	CERTIFICATION BONUSES	0.00	1,662.00	1,662.00	0.00	0.00	1,662.00	0.00
203-3463-71500	SOCIAL SECURITY	73,174.16	103,325.00	103,325.00	65,610.56	0.00	37,714.44	63.50
203-3463-71900	EMPLOYEE INSURANCES	248,729.28	389,933.00	389,933.00	214,316.71	0.00	175,616.29	54.96
203-3463-71904	RETIREE HEALTH INSURANCE	249,700.00	257,567.00	257,567.00	214,640.00	0.00	42,927.00	83.33
203-3463-71905	H.S.A. EXPENSE	7,836.55	14,958.00	14,958.00	9,639.87	0.00	5,318.13	64.45
203-3463-71906	SUPPL LIFE INSURANCE EXP	898.00	927.00	927.00	0.00	0.00	927.00	0.00
203-3463-72100	LONGEVITY	34,444.58	50,459.00	50,459.00	0.00	0.00	50,459.00	0.00
203-3463-72101	BONUS/SICK REDEMPTION	0.00	47,997.00	47,997.00	0.00	0.00	47,997.00	0.00
203-3463-72200	RETIREMENT FUND	393,871.00	374,021.00	374,021.00	311,680.00	0.00	62,341.00	83.33
203-3463-72201	DEFINED CONTRIBUTION EXP	71,280.57	111,397.00	111,397.00	71,095.96	0.00	40,301.04	63.82
203-3474-70600	PERMANENT EMPLOYEES	72,367.42	87,848.00	87,848.00	53,382.19	0.00	34,465.81	60.77
203-3474-70900	OVERTIME	0.00	8,963.00	8,963.00	49.64	0.00	8,913.36	0.55
203-3474-71302	EDUCATION ALLOWANCE	48.75	143.00	143.00	0.00	0.00	143.00	0.00
203-3474-71303	CLEAN/CLOTHING ALLOWANCE	0.00	418.00	418.00	0.00	0.00	418.00	0.00
203-3474-71308	CERTIFICATION BONUSES	0.00	134.00	134.00	0.00	0.00	134.00	0.00
203-3474-71500	SOCIAL SECURITY	5,748.39	8,066.00	8,066.00	5,779.62	0.00	2,286.38	71.65
203-3474-71900	EMPLOYEE INSURANCES	21,773.63	31,398.00	31,398.00	15,269.73	0.00	16,128.27	48.63
203-3474-71904	RETIREE HEALTH INSURANCE	21,564.00	20,740.00	20,740.00	17,280.00	0.00	3,460.00	83.32
203-3474-71905	H.S.A. EXPENSE	568.90	1,204.00	1,204.00	807.28	0.00	396.72	67.05
203-3474-71906	SUPPL LIFE INSURANCE EXP	78.00	75.00	75.00	0.00	0.00	75.00	0.00
203-3474-72100	LONGEVITY	2,976.92	4,063.00	4,063.00	0.00	0.00	4,063.00	0.00
203-3474-72101	BONUS/SICK REDEMPTION	0.00	3,865.00	3,865.00	0.00	0.00	3,865.00	0.00
203-3474-72200	RETIREMENT FUND	34,015.00	30,117.00	30,117.00	25,100.00	0.00	5,017.00	83.34
203-3474-72201	DEFINED CONTRIBUTION EXP	2,829.68	8,970.00	8,970.00	4,036.74	0.00	4,933.26	45.00
203-3479-70600	PERMANENT EMPLOYEES	15,264.01	37,602.00	37,602.00	13,936.42	0.00	23,665.58	37.06
203-3479-70900	OVERTIME	12,348.43	3,836.00	3,836.00	9,267.83	0.00	(5,431.83)	241.60
203-3479-71302	EDUCATION ALLOWANCE	14.27	61.00	61.00	0.00	0.00	61.00	0.00
203-3479-71303	CLEAN/CLOTHING ALLOWANCE	0.00	179.00	179.00	0.00	0.00	179.00	0.00
203-3479-71308	CERTIFICATION BONUSES	0.00	57.00	57.00	0.00	0.00	57.00	0.00
203-3479-71500	SOCIAL SECURITY	2,262.55	3,453.00	3,453.00	1,927.51	0.00	1,525.49	55.82
203-3479-71900	EMPLOYEE INSURANCES	6,069.92	13,439.00	13,439.00	4,310.91	0.00	9,128.09	32.08
203-3479-71904	RETIREE HEALTH INSURANCE	17,225.00	8,877.00	8,877.00	7,400.00	0.00	1,477.00	83.36
203-3479-71905	H.S.A. EXPENSE	261.39	516.00	516.00	295.63	0.00	220.37	57.29
203-3479-71906	SUPPL LIFE INSURANCE EXP	31.44	32.00	32.00	0.00	0.00	32.00	0.00
203-3479-72100	LONGEVITY	871.19	1,739.00	1,739.00	0.00	0.00	1,739.00	0.00
203-3479-72101	BONUS/SICK REDEMPTION	0.00	1,654.00	1,654.00	0.00	0.00	1,654.00	0.00
203-3479-72200	RETIREMENT FUND	27,171.00	12,891.00	12,891.00	10,740.00	0.00	2,151.00	83.31
203-3479-72201	DEFINED CONTRIBUTION EXP	2,050.71	3,839.00	3,839.00	2,009.97	0.00	1,829.03	52.36
203-3483-70500	SUPERVISORY	53,472.63	103,743.00	103,743.00	45,468.64	0.00	58,274.36	43.83
203-3483-70602	CLERICAL	54,789.98	101,683.00	101,683.00	47,777.12	0.00	53,905.88	46.99
203-3483-70700	TEMPORARY EMPLOYEES	0.00	17,500.00	17,500.00	0.00	0.00	17,500.00	0.00
203-3483-70902	OVERTIME - CLERICAL	801.72	5,000.00	5,000.00	2,284.80	0.00	2,715.20	45.70
203-3483-71303	CLEAN/CLOTHING ALLOWANCE	500.00	875.00	875.00	583.33	0.00	291.67	66.67
203-3483-71500	SOCIAL SECURITY	9,077.89	18,827.00	18,827.00	9,743.23	0.00	9,083.77	51.75
203-3483-71900	EMPLOYEE INSURANCES	23,208.21	40,093.00	40,093.00	15,490.42	0.00	24,602.58	38.64
203-3483-71904	RETIREE HEALTH INSURANCE	22,836.00	22,836.00	22,836.00	19,030.00	0.00	3,806.00	83.33

REVENUE AND EXPENDITURE REPORT

PERIOD ENDING 04/30/2024

% Fiscal Year Completed: 83.33

GL NUMBER	DESCRIPTION	END BALANCE	2023-24		YTD BALANCE	ENCUMBERED	UNENCUMBERED	% BDGT
		06/30/2023	ORIGINAL	2023-24	04/30/2024			
		NORM (ABNORM)	BUDGET	AMENDED BUDGET	NORM (ABNORM)	YEAR-TO-DATE	BALANCE	USED
203-3483-71905	H.S.A. EXPENSE	500.20	2,636.00	2,636.00	474.49	0.00	2,161.51	18.00
203-3483-71906	SUPPL LIFE INSURANCE EXP	259.69	327.00	327.00	199.50	0.00	127.50	61.01
203-3483-72100	LONGEVITY	4,398.36	7,828.00	7,828.00	3,719.98	0.00	4,108.02	47.52
203-3483-72101	BONUS/SICK REDEMPTION	4,827.38	9,445.00	9,445.00	14,369.57	0.00	(4,924.57)	152.14
203-3483-72200	RETIREMENT FUND	31,109.00	28,639.00	28,639.00	23,870.00	0.00	4,769.00	83.35
203-3483-72201	DEFINED CONTRIBUTION EXP	6,195.71	19,668.00	19,668.00	8,502.80	0.00	11,165.20	43.23
208-9208-70300	APPOINTED OFFICIAL	118,121.81	121,672.00	121,672.00	102,346.76	0.00	19,325.24	84.12
208-9208-70610	MAINTENANCE	112,974.70	219,720.00	219,720.00	123,298.69	0.00	96,421.31	56.12
208-9208-70612	RECREATION SUPERVISION	353,819.38	391,768.00	391,768.00	298,232.31	0.00	93,535.69	76.12
208-9208-70710	TEMPORARY - MAINTENANCE	0.00	85,000.00	85,000.00	0.00	0.00	85,000.00	0.00
208-9208-70713	TEMPORARY - RECREATION	756,225.23	930,000.00	930,000.00	787,617.24	0.00	142,382.76	84.69
208-9208-70910	OVERTIME - MAINTENANCE	7,139.26	20,000.00	20,000.00	5,933.47	0.00	14,066.53	29.67
208-9208-70912	OVERTIME - REC SUPV	0.00	5,000.00	5,000.00	873.84	0.00	4,126.16	17.48
208-9208-71302	EDUCATION ALLOWANCE	2,500.00	4,500.00	4,500.00	2,500.00	0.00	2,000.00	55.56
208-9208-71303	CLEAN/CLOTHING ALLOWANCE	2,400.00	3,850.00	3,850.00	3,412.50	0.00	437.50	88.64
208-9208-71500	SOCIAL SECURITY	97,668.92	139,432.00	139,432.00	97,492.54	0.00	41,939.46	69.92
208-9208-71900	EMPLOYEE INSURANCES	158,121.13	373,659.00	373,659.00	181,668.25	0.00	191,990.75	48.62
208-9208-71904	RETIREE HEALTH INSURANCE	251,196.00	251,196.00	251,196.00	209,330.00	0.00	41,866.00	83.33
208-9208-71905	H.S.A. EXPENSE	8,758.05	12,150.00	12,150.00	8,291.01	0.00	3,858.99	68.24
208-9208-71906	SUPPL LIFE INSURANCE EXP	936.00	1,284.00	1,284.00	806.00	0.00	478.00	62.77
208-9208-72100	LONGEVITY	11,685.70	13,419.00	13,419.00	12,900.23	0.00	518.77	96.13
208-9208-72101	BONUS/SICK REDEMPTION	20,004.64	27,584.00	27,584.00	27,604.12	0.00	(20.12)	100.07
208-9208-72200	RETIREMENT FUND	186,654.00	171,837.00	171,837.00	143,200.00	0.00	28,637.00	83.33
208-9208-72201	DEFINED CONTRIBUTION EXP	72,665.72	92,202.00	92,202.00	66,075.19	0.00	26,126.81	71.66
208-9210-70713	TEMPORARY - RECREATION	121,527.40	140,000.00	140,000.00	111,119.49	0.00	28,880.51	79.37
208-9210-71500	SOCIAL SECURITY	9,296.90	10,710.00	10,710.00	8,500.56	0.00	2,209.44	79.37
208-9210-71900	EMPLOYEE INSURANCES	1,957.87	3,311.00	3,311.00	2,668.09	0.00	642.91	80.58
226-9226-70501	SUPERINTENDENT	182,794.01	287,294.00	287,294.00	128,639.23	0.00	158,654.77	44.78
226-9226-70602	CLERICAL	82,234.03	145,407.00	145,407.00	80,286.25	0.00	65,120.75	55.21
226-9226-70611	RUBBISH WAGES	1,537,385.86	1,994,006.00	1,994,006.00	1,201,958.21	0.00	792,047.79	60.28
226-9226-70703	CLERICAL CO-OP	9,208.80	0.00	0.00	0.00	0.00	0.00	0.00
226-9226-70711	TEMPORARY - RUBBISH COLL	81,771.51	220,000.00	220,000.00	107,203.41	0.00	112,796.59	48.73
226-9226-70902	OVERTIME - CLERICAL	11,244.41	13,000.00	13,000.00	11,198.82	0.00	1,801.18	86.14
226-9226-70911	OVERTIME - RUBBISH COLL	569,403.24	500,000.00	500,000.00	404,149.56	0.00	95,850.44	80.83
226-9226-71302	EDUCATION ALLOWANCE	1,333.33	2,000.00	2,000.00	1,166.67	0.00	833.33	58.33
226-9226-71303	CLEAN/CLOTHING ALLOWANCE	8,677.07	13,300.00	13,300.00	10,266.67	0.00	3,033.33	77.19
226-9226-71500	SOCIAL SECURITY	192,216.54	248,390.00	248,390.00	150,825.87	0.00	97,564.13	60.72
226-9226-71900	EMPLOYEE INSURANCES	522,838.62	1,095,523.00	1,095,523.00	533,755.40	0.00	561,767.60	48.72
226-9226-71904	RETIREE HEALTH INSURANCE	502,392.00	502,392.00	502,392.00	418,660.00	0.00	83,732.00	83.33
226-9226-71905	H.S.A. EXPENSE	31,901.53	54,288.00	54,288.00	28,580.95	0.00	25,707.05	52.65
226-9226-71906	SUPPL LIFE INSURANCE EXP	2,133.06	4,608.00	4,608.00	1,873.34	0.00	2,734.66	40.65
226-9226-72100	LONGEVITY	39,001.04	43,031.00	43,031.00	19,370.80	0.00	23,660.20	45.02
226-9226-72101	BONUS/SICK REDEMPTION	17,630.86	28,274.00	28,274.00	28,926.16	0.00	(652.16)	102.31
226-9226-72200	RETIREMENT FUND	622,180.00	572,780.00	572,780.00	477,320.00	0.00	95,460.00	83.33
226-9226-72201	DEFINED CONTRIBUTION EXP	200,487.95	307,214.00	307,214.00	168,761.52	0.00	138,452.48	54.93
230-9230-70600	PERMANENT EMPLOYEES	372,504.76	397,920.00	397,920.00	314,735.85	0.00	83,184.15	79.10
230-9230-70700	TEMPORARY EMPLOYEES	34,012.80	80,000.00	80,000.00	22,649.00	0.00	57,351.00	28.31
230-9230-70705	TEMPORARY - INSPECTION	136,489.05	200,000.00	200,000.00	71,482.50	0.00	128,517.50	35.74
230-9230-70902	OVERTIME - CLERICAL	1,430.11	10,000.00	10,000.00	625.11	0.00	9,374.89	6.25
230-9230-71303	CLEAN/CLOTHING ALLOWANCE	2,100.00	2,100.00	2,100.00	2,100.00	0.00	0.00	100.00
230-9230-71500	SOCIAL SECURITY	42,863.52	54,724.00	54,724.00	32,027.24	0.00	22,696.76	58.53
230-9230-71900	EMPLOYEE INSURANCES	105,015.58	150,753.00	150,753.00	97,438.63	0.00	53,314.37	64.63
230-9230-71904	RETIREE HEALTH INSURANCE	22,837.00	22,837.00	22,837.00	19,030.00	0.00	3,807.00	83.33
230-9230-71905	H.S.A. EXPENSE	7,963.92	8,709.00	8,709.00	6,618.46	0.00	2,090.54	76.00
230-9230-71906	SUPPL LIFE INSURANCE EXP	482.46	776.00	776.00	322.50	0.00	453.50	41.56
230-9230-72100	LONGEVITY	7,231.82	8,814.00	8,814.00	8,762.02	0.00	51.98	99.41
230-9230-72101	BONUS/SICK REDEMPTION	14,081.74	16,428.00	16,428.00	4,644.79	0.00	11,783.21	28.27
230-9230-72201	DEFINED CONTRIBUTION EXP	39,819.42	43,529.00	43,529.00	33,092.15	0.00	10,436.85	76.02

REVENUE AND EXPENDITURE REPORT

PERIOD ENDING 04/30/2024

% Fiscal Year Completed: 83.33

GL NUMBER	DESCRIPTION	END BALANCE	2023-24		YTD BALANCE	ENCUMBERED	UNENCUMBERED	% BDGT
		06/30/2023	ORIGINAL	2023-24	04/30/2024			
		NORM (ABNORM)	BUDGET	AMENDED BUDGET	NORM (ABNORM)	YEAR-TO-DATE	BALANCE	USED
230-9230-72501	FEES & PER DIEM	0.00	1,800.00	1,800.00	0.00	0.00	1,800.00	0.00
250-9250-70600	PERMANENT EMPLOYEES	341,466.21	431,971.00	431,971.00	325,863.68	0.00	106,107.32	75.44
250-9250-70700	TEMPORARY EMPLOYEES	167,551.54	300,000.00	300,000.00	76,880.18	0.00	223,119.82	25.63
250-9250-70900	OVERTIME	1,353.48	7,613.00	7,613.00	5,783.54	0.00	1,829.46	75.97
250-9250-71302	EDUCATION ALLOWANCE	2,000.00	3,500.00	3,500.00	3,000.00	0.00	500.00	85.71
250-9250-71303	CLEAN/CLOTHING ALLOWANCE	1,850.00	2,100.00	2,100.00	1,750.00	0.00	350.00	83.33
250-9250-71500	SOCIAL SECURITY	39,312.02	58,925.00	58,925.00	31,890.74	0.00	27,034.26	54.12
250-9250-71900	EMPLOYEE INSURANCES	82,071.88	193,132.00	193,132.00	76,018.86	0.00	117,113.14	39.36
250-9250-71904	RETIREE HEALTH INSURANCE	68,511.00	68,511.00	68,511.00	57,090.00	0.00	11,421.00	83.33
250-9250-71905	H.S.A. EXPENSE	5,585.63	7,842.00	7,842.00	5,702.37	0.00	2,139.63	72.72
250-9250-71906	SUPPL LIFE INSURANCE EXP	48.00	720.00	720.00	49.04	0.00	670.96	6.81
250-9250-72100	LONGEVITY	6,621.50	8,202.00	8,202.00	6,718.14	0.00	1,483.86	81.91
250-9250-72101	BONUS/SICK REDEMPTION	0.00	16,774.00	16,774.00	3,789.99	0.00	12,984.01	22.59
250-9250-72200	RETIREMENT FUND	62,217.00	57,278.00	57,278.00	47,730.00	0.00	9,548.00	83.33
250-9250-72201	DEFINED CONTRIBUTION EXP	35,252.83	47,020.00	47,020.00	34,690.04	0.00	12,329.96	73.78
259-9259-70600	PERMANENT EMPLOYEES	53,517.73	0.00	77,089.40	46,412.77	0.00	30,676.63	60.21
259-9259-71500	SOCIAL SECURITY	4,225.69	0.00	5,869.01	3,550.43	0.00	2,318.58	60.49
259-9259-71900	EMPLOYEE INSURANCES	6,330.55	0.00	23,664.94	9,949.05	0.00	13,715.89	42.04
259-9259-71905	H.S.A. EXPENSE	1,130.47	0.00	1,541.79	953.28	0.00	588.51	61.83
259-9259-72201	DEFINED CONTRIBUTION EXP	5,651.86	0.00	7,708.89	4,766.35	0.00	2,942.54	61.83
271-9271-70300	APPOINTED OFFICIAL	110,290.77	113,605.00	113,605.00	90,966.43	0.00	22,638.57	80.07
271-9271-70600	PERMANENT EMPLOYEES	1,392,149.67	1,491,091.00	1,478,091.00	1,150,341.86	0.00	327,749.14	77.83
271-9271-70714	PERMANENT PART-TIME EMP	150,913.80	300,000.00	300,000.00	144,155.25	0.00	155,844.75	48.05
271-9271-70900	OVERTIME	316.60	20,000.00	20,000.00	222.30	0.00	19,777.70	1.11
271-9271-71000	SHIFT PREMIUM	9,909.75	15,500.00	15,500.00	6,845.27	0.00	8,654.73	44.16
271-9271-71302	EDUCATION ALLOWANCE	17,900.00	26,500.00	26,500.00	22,000.00	0.00	4,500.00	83.02
271-9271-71303	CLEAN/CLOTHING ALLOWANCE	7,650.00	8,400.00	8,575.00	8,575.00	0.00	0.00	100.00
271-9271-71500	SOCIAL SECURITY	131,794.22	158,537.00	158,537.00	112,271.19	0.00	46,265.81	70.82
271-9271-71900	EMPLOYEE INSURANCES	335,612.10	465,290.00	465,290.00	330,533.35	0.00	134,756.65	71.04
271-9271-71904	RETIREE HEALTH INSURANCE	182,696.00	182,696.00	182,696.00	152,250.00	0.00	30,446.00	83.34
271-9271-71905	H.S.A. EXPENSE	24,036.66	26,977.00	26,977.00	20,106.20	0.00	6,870.80	74.53
271-9271-71906	SUPPL LIFE INSURANCE EXP	1,978.50	2,328.00	2,328.00	1,784.44	0.00	543.56	76.65
271-9271-72100	LONGEVITY	38,094.58	43,755.00	43,755.00	31,132.96	0.00	12,622.04	71.15
271-9271-72101	BONUS/SICK REDEMPTION	18,752.67	53,228.00	53,228.00	29,424.73	0.00	23,803.27	55.28
271-9271-72200	RETIREMENT FUND	373,308.00	343,668.00	343,668.00	286,390.00	0.00	57,278.00	83.33
271-9271-72201	DEFINED CONTRIBUTION EXP	144,342.34	171,579.00	171,579.00	121,444.50	0.00	50,134.50	70.78
273-9666-70600-CD1713	PERMANENT EMPLOYEES	0.00	112,348.12	0.00	0.00	0.00	0.00	0.00
273-9666-70600-CD1812	PERMANENT EMPLOYEES	0.00	90,849.74	0.00	0.00	0.00	0.00	0.00
273-9666-70600-CD1912	PERMANENT EMPLOYEES	0.00	131,480.33	0.00	0.00	0.00	0.00	0.00
273-9666-70600-CD2015	PERMANENT EMPLOYEES	0.00	89,230.63	0.00	0.00	0.00	0.00	0.00
273-9666-70600-CD2115	PERMANENT EMPLOYEES	26,787.30	147,420.15	0.00	0.00	0.00	0.00	0.00
273-9666-70600-CD2213	PERMANENT EMPLOYEES	76,518.11	21,932.53	0.00	0.00	0.00	0.00	0.00
273-9666-70712-CD1713	TEMPORARY - PLANNING AIDE	0.00	16,238.02	0.00	0.00	0.00	0.00	0.00
273-9666-70712-CD1812	TEMPORARY - PLANNING AIDE	0.00	15,377.53	0.00	0.00	0.00	0.00	0.00
273-9666-70712-CD1912	TEMPORARY - PLANNING AIDE	0.00	13,435.00	0.00	0.00	0.00	0.00	0.00
273-9666-70712-CD2015	TEMPORARY - PLANNING AIDE	0.00	19,650.00	0.00	0.00	0.00	0.00	0.00
273-9666-70712-CD2115	TEMPORARY - PLANNING AIDE	(146.25)	66,158.25	0.00	0.00	0.00	0.00	0.00
273-9666-70712-CD2213	TEMPORARY - PLANNING AIDE	6,750.00	6,175.00	0.00	0.00	0.00	0.00	0.00
273-9666-71302-CD1713	EDUCATION ALLOWANCE	0.00	1,150.00	0.00	0.00	0.00	0.00	0.00
273-9666-71302-CD1812	EDUCATION ALLOWANCE	0.00	2,350.00	0.00	0.00	0.00	0.00	0.00
273-9666-71302-CD1912	EDUCATION ALLOWANCE	0.00	2,350.00	0.00	0.00	0.00	0.00	0.00
273-9666-71302-CD2015	EDUCATION ALLOWANCE	0.00	2,350.00	0.00	0.00	0.00	0.00	0.00
273-9666-71302-CD2115	EDUCATION ALLOWANCE	0.00	800.00	0.00	0.00	0.00	0.00	0.00
273-9666-71302-CD2213	EDUCATION ALLOWANCE	1,400.00	1,500.00	0.00	0.00	0.00	0.00	0.00
273-9666-71303-CD2213	CLEAN/CLOTHING ALLOWANCE	700.00	350.00	0.00	0.00	0.00	0.00	0.00
273-9666-71500-CD1713	SOCIAL SECURITY	0.00	9,209.60	0.00	0.00	0.00	0.00	0.00
273-9666-71500-CD1812	SOCIAL SECURITY	0.00	7,378.80	0.00	0.00	0.00	0.00	0.00
273-9666-71500-CD1912	SOCIAL SECURITY	0.00	9,539.84	0.00	0.00	0.00	0.00	0.00

REVENUE AND EXPENDITURE REPORT

PERIOD ENDING 04/30/2024

% Fiscal Year Completed: 83.33

GL NUMBER	DESCRIPTION	END BALANCE	2023-24		YTD BALANCE	ENCUMBERED	UNENCUMBERED	% BGD
		06/30/2023	ORIGINAL	2023-24	04/30/2024			
		NORM (ABNORM)	BUDGET	AMENDED BUDGET	NORM (ABNORM)	YEAR-TO-DATE	BALANCE	USED
273-9666-71500-CD2015	SOCIAL SECURITY	0.00	4,859.60	0.00	0.00	0.00	0.00	0.00
273-9666-71500-CD2115	SOCIAL SECURITY	2,377.93	11,559.29	0.00	0.00	0.00	0.00	0.00
273-9666-71500-CD2213	SOCIAL SECURITY	7,518.24	182.76	0.00	0.00	0.00	0.00	0.00
273-9666-71900-CD2115	EMPLOYEE INSURANCES	629.40	10,002.11	0.00	0.00	0.00	0.00	0.00
273-9666-71900-CD2213	EMPLOYEE INSURANCES	49,703.15	0.00	0.00	0.00	0.00	0.00	0.00
273-9666-71904-CD1713	RETIREE HEALTH INSURANCE	0.00	67,169.12	0.00	0.00	0.00	0.00	0.00
273-9666-71904-CD1812	RETIREE HEALTH INSURANCE	0.00	13,985.33	0.00	0.00	0.00	0.00	0.00
273-9666-71904-CD1912	RETIREE HEALTH INSURANCE	0.00	12,356.53	0.00	0.00	0.00	0.00	0.00
273-9666-71904-CD2015	RETIREE HEALTH INSURANCE	0.00	18,781.32	0.00	0.00	0.00	0.00	0.00
273-9666-71904-CD2115	RETIREE HEALTH INSURANCE	0.00	20,591.15	0.00	0.00	0.00	0.00	0.00
273-9666-71904-CD2213	RETIREE HEALTH INSURANCE	(10,585.03)	34,585.03	0.00	0.00	0.00	0.00	0.00
273-9666-71905-CD2213	H.S.A. EXPENSE	105.00	0.00	0.00	0.00	0.00	0.00	0.00
273-9666-71906-CD1713	SUPPL LIFE INSURANCE EXP	0.00	269.40	0.00	0.00	0.00	0.00	0.00
273-9666-71906-CD1812	SUPPL LIFE INSURANCE EXP	0.00	236.40	0.00	0.00	0.00	0.00	0.00
273-9666-71906-CD1912	SUPPL LIFE INSURANCE EXP	0.00	300.00	0.00	0.00	0.00	0.00	0.00
273-9666-71906-CD2015	SUPPL LIFE INSURANCE EXP	0.00	175.20	0.00	0.00	0.00	0.00	0.00
273-9666-71906-CD2115	SUPPL LIFE INSURANCE EXP	60.00	240.00	0.00	0.00	0.00	0.00	0.00
273-9666-71906-CD2213	SUPPL LIFE INSURANCE EXP	0.00	300.00	0.00	0.00	0.00	0.00	0.00
273-9666-72100-CD1713	LONGEVITY	0.00	4,400.00	0.00	0.00	0.00	0.00	0.00
273-9666-72100-CD1812	LONGEVITY	0.00	8,345.89	0.00	0.00	0.00	0.00	0.00
273-9666-72100-CD1912	LONGEVITY	0.00	6,744.98	0.00	0.00	0.00	0.00	0.00
273-9666-72100-CD2015	LONGEVITY	0.00	7,624.00	0.00	0.00	0.00	0.00	0.00
273-9666-72100-CD2115	LONGEVITY	0.00	9,773.82	0.00	0.00	0.00	0.00	0.00
273-9666-72100-CD2213	LONGEVITY	8,282.32	1,317.68	0.00	0.00	0.00	0.00	0.00
273-9666-72201-CD1713	DEFINED CONTRIBUTION EXP	0.00	15,479.81	0.00	0.00	0.00	0.00	0.00
273-9666-72201-CD1812	DEFINED CONTRIBUTION EXP	0.00	13,904.13	0.00	0.00	0.00	0.00	0.00
273-9666-72201-CD1912	DEFINED CONTRIBUTION EXP	0.00	18,782.94	0.00	0.00	0.00	0.00	0.00
273-9666-72201-CD2015	DEFINED CONTRIBUTION EXP	0.00	13,754.51	0.00	0.00	0.00	0.00	0.00
273-9666-72201-CD2115	DEFINED CONTRIBUTION EXP	4,993.52	18,652.20	0.00	0.00	0.00	0.00	0.00
273-9666-72201-CD2213	DEFINED CONTRIBUTION EXP	10,782.36	3,924.73	0.00	0.00	0.00	0.00	0.00
273-9706-70600-CD1702	PERMANENT EMPLOYEES	0.00	9,539.70	0.00	0.00	0.00	0.00	0.00
273-9706-70600-CD1902	PERMANENT EMPLOYEES	0.00	21,062.49	0.00	0.00	0.00	0.00	0.00
273-9706-70600-CD2003	PERMANENT EMPLOYEES	0.00	24,664.20	0.00	0.00	0.00	0.00	0.00
273-9706-70600-CD2103	PERMANENT EMPLOYEES	370.53	39,629.47	0.00	0.00	0.00	0.00	0.00
273-9706-70600-CD2202	PERMANENT EMPLOYEES	0.00	7,150.00	0.00	0.00	0.00	0.00	0.00
273-9706-70609-CD1602	INSPECTORS	0.00	30,000.00	0.00	0.00	0.00	0.00	0.00
273-9706-70609-CD1702	INSPECTORS	0.00	60,565.47	0.00	0.00	0.00	0.00	0.00
273-9706-70609-CD1802	INSPECTORS	0.00	52,712.28	0.00	0.00	0.00	0.00	0.00
273-9706-70609-CD1902	INSPECTORS	0.00	84,026.26	0.00	0.00	0.00	0.00	0.00
273-9706-70609-CD2003	INSPECTORS	293.61	39,014.34	0.00	0.00	0.00	0.00	0.00
273-9706-70609-CD2103	INSPECTORS	11,712.71	45,300.03	0.00	0.00	0.00	0.00	0.00
273-9706-70609-CD2202	INSPECTORS	74,116.12	0.00	0.00	0.00	0.00	0.00	0.00
273-9706-70705-CD1802	TEMPORARY - INSPECTION	0.00	10,000.00	0.00	0.00	0.00	0.00	0.00
273-9706-70705-CD1902	TEMPORARY - INSPECTION	0.00	11,000.00	0.00	0.00	0.00	0.00	0.00
273-9706-70705-CD2003	TEMPORARY - INSPECTION	0.00	10,000.00	0.00	0.00	0.00	0.00	0.00
273-9706-70705-CD2103	TEMPORARY - INSPECTION	0.00	3,300.00	0.00	0.00	0.00	0.00	0.00
273-9706-70712-CD1702	TEMPORARY - PLANNING AIDE	0.00	8,043.84	0.00	0.00	0.00	0.00	0.00
273-9706-70712-CD1802	TEMPORARY - PLANNING AIDE	0.00	9,000.00	0.00	0.00	0.00	0.00	0.00
273-9706-70712-CD1902	TEMPORARY - PLANNING AIDE	0.00	1,000.00	0.00	0.00	0.00	0.00	0.00
273-9706-70712-CD2003	TEMPORARY - PLANNING AIDE	0.00	8,092.50	0.00	0.00	0.00	0.00	0.00
273-9706-70712-CD2103	TEMPORARY - PLANNING AIDE	1,066.50	7,933.50	0.00	0.00	0.00	0.00	0.00
273-9706-70712-CD2202	TEMPORARY - PLANNING AIDE	0.00	3,500.00	0.00	0.00	0.00	0.00	0.00
273-9706-71302-CD2202	EDUCATION ALLOWANCE	400.00	100.00	0.00	0.00	0.00	0.00	0.00
273-9706-71303-CD2202	CLEAN/CLOTHING ALLOWANCE	350.00	0.00	0.00	0.00	0.00	0.00	0.00
273-9706-71500-CD1702	SOCIAL SECURITY	0.00	6,057.25	0.00	0.00	0.00	0.00	0.00
273-9706-71500-CD1802	SOCIAL SECURITY	0.00	7,404.53	0.00	0.00	0.00	0.00	0.00
273-9706-71500-CD1902	SOCIAL SECURITY	0.00	10,872.08	0.00	0.00	0.00	0.00	0.00
273-9706-71500-CD2003	SOCIAL SECURITY	22.01	7,951.15	0.00	0.00	0.00	0.00	0.00

REVENUE AND EXPENDITURE REPORT

PERIOD ENDING 04/30/2024

% Fiscal Year Completed: 83.33

GL NUMBER	DESCRIPTION	END BALANCE	2023-24		YTD BALANCE	ENCUMBERED	UNENCUMBERED	% BGD
		06/30/2023	ORIGINAL	2023-24	04/30/2024			
		NORM (ABNORM)	BUDGET	AMENDED BUDGET	NORM (ABNORM)	YEAR-TO-DATE	BALANCE	USED
273-9706-71500-CD2103	SOCIAL SECURITY	1,040.39	7,459.60	0.00	0.00	0.00	0.00	0.00
273-9706-71500-CD2202	SOCIAL SECURITY	5,620.00	0.00	0.00	0.00	0.00	0.00	0.00
273-9706-71900-CD2202	EMPLOYEE INSURANCES	31,955.01	0.00	0.00	0.00	0.00	0.00	0.00
273-9706-71905-CD1702	H.S.A. EXPENSE	0.00	689.37	0.00	0.00	0.00	0.00	0.00
273-9706-71905-CD1802	H.S.A. EXPENSE	0.00	745.17	0.00	0.00	0.00	0.00	0.00
273-9706-71905-CD1902	H.S.A. EXPENSE	0.00	1,200.00	0.00	0.00	0.00	0.00	0.00
273-9706-71905-CD2003	H.S.A. EXPENSE	5.87	1,194.13	0.00	0.00	0.00	0.00	0.00
273-9706-71905-CD2103	H.S.A. EXPENSE	0.00	1,760.22	0.00	0.00	0.00	0.00	0.00
273-9706-71905-CD2202	H.S.A. EXPENSE	1,526.91	0.00	0.00	0.00	0.00	0.00	0.00
273-9706-71906-CD1702	SUPPL LIFE INSURANCE EXP	0.00	250.00	0.00	0.00	0.00	0.00	0.00
273-9706-71906-CD1802	SUPPL LIFE INSURANCE EXP	0.00	250.00	0.00	0.00	0.00	0.00	0.00
273-9706-71906-CD1902	SUPPL LIFE INSURANCE EXP	0.00	300.00	0.00	0.00	0.00	0.00	0.00
273-9706-71906-CD2003	SUPPL LIFE INSURANCE EXP	0.00	300.00	0.00	0.00	0.00	0.00	0.00
273-9706-71906-CD2103	SUPPL LIFE INSURANCE EXP	0.00	284.50	0.00	0.00	0.00	0.00	0.00
273-9706-71906-CD2202	SUPPL LIFE INSURANCE EXP	312.00	501.00	0.00	0.00	0.00	0.00	0.00
273-9706-72201-CD1702	DEFINED CONTRIBUTION EXP	0.00	7,395.44	0.00	0.00	0.00	0.00	0.00
273-9706-72201-CD1802	DEFINED CONTRIBUTION EXP	0.00	11,763.07	0.00	0.00	0.00	0.00	0.00
273-9706-72201-CD1902	DEFINED CONTRIBUTION EXP	0.00	16,702.39	0.00	0.00	0.00	0.00	0.00
273-9706-72201-CD2003	DEFINED CONTRIBUTION EXP	29.36	13,134.43	0.00	0.00	0.00	0.00	0.00
273-9706-72201-CD2103	DEFINED CONTRIBUTION EXP	2,056.05	10,314.21	0.00	0.00	0.00	0.00	0.00
273-9706-72201-CD2202	DEFINED CONTRIBUTION EXP	7,634.79	650.27	0.00	0.00	0.00	0.00	0.00
277-9777-70600-HM2105	PERMANENT EMPLOYEES	0.00	35,842.00	35,842.00	0.00	0.00	35,842.00	0.00
277-9777-70600-HM2204	PERMANENT EMPLOYEES	0.00	35,842.00	35,842.00	0.00	0.00	35,842.00	0.00
277-9777-70712-HM2105	TEMPORARY - PLANNING AIDE	0.00	2,000.00	2,000.00	0.00	0.00	2,000.00	0.00
277-9777-70712-HM2204	TEMPORARY - PLANNING AIDE	0.00	3,560.00	3,560.00	0.00	0.00	3,560.00	0.00
277-9777-71500-HM2105	SOCIAL SECURITY	0.00	2,000.00	2,000.00	0.00	0.00	2,000.00	0.00
277-9777-71500-HM2204	SOCIAL SECURITY	0.00	2,000.00	2,000.00	0.00	0.00	2,000.00	0.00
277-9777-71900-HM2105	EMPLOYEE INSURANCES	0.00	4,500.00	4,500.00	0.00	0.00	4,500.00	0.00
277-9777-71900-HM2204	EMPLOYEE INSURANCES	0.00	4,500.00	4,500.00	0.00	0.00	4,500.00	0.00
277-9777-71904-HM2105	RETIREE HEALTH INSURANCE	0.00	2,000.00	2,000.00	0.00	0.00	2,000.00	0.00
277-9777-71904-HM2204	RETIREE HEALTH INSURANCE	0.00	3,000.00	3,000.00	0.00	0.00	3,000.00	0.00
277-9777-72201-HM2105	DEFINED CONTRIBUTION EXP	0.00	3,472.00	3,472.00	0.00	0.00	3,472.00	0.00
277-9777-72201-HM2204	DEFINED CONTRIBUTION EXP	0.00	3,472.00	3,472.00	0.00	0.00	3,472.00	0.00
278-9778-70600-WA2005	PERMANENT EMPLOYEES	4,133.76	0.00	0.00	0.00	0.00	0.00	0.00
278-9778-70600-WA2105	PERMANENT EMPLOYEES	3,854.88	11,600.12	0.00	0.00	0.00	0.00	0.00
278-9778-70600-WA2205	PERMANENT EMPLOYEES	0.00	21,000.00	0.00	0.00	0.00	0.00	0.00
278-9778-71500-WA2005	SOCIAL SECURITY	316.24	0.00	0.00	0.00	0.00	0.00	0.00
278-9778-71500-WA2105	SOCIAL SECURITY	315.92	934.08	0.00	0.00	0.00	0.00	0.00
278-9778-71500-WA2205	SOCIAL SECURITY	0.00	1,215.00	0.00	0.00	0.00	0.00	0.00
278-9778-71900-WA2005	EMPLOYEE INSURANCES	454.71	0.00	0.00	0.00	0.00	0.00	0.00
278-9778-71900-WA2105	EMPLOYEE INSURANCES	0.00	1,600.00	0.00	0.00	0.00	0.00	0.00
278-9778-71900-WA2205	EMPLOYEE INSURANCES	0.00	2,500.00	0.00	0.00	0.00	0.00	0.00
278-9778-71904-WA2005	RETIREE HEALTH INSURANCE	516.22	0.00	0.00	0.00	0.00	0.00	0.00
278-9778-71904-WA2105	RETIREE HEALTH INSURANCE	1,588.71	25.29	0.00	0.00	0.00	0.00	0.00
278-9778-71904-WA2205	RETIREE HEALTH INSURANCE	0.00	1,500.00	0.00	0.00	0.00	0.00	0.00
278-9778-72201-WA2005	DEFINED CONTRIBUTION EXP	620.06	0.00	0.00	0.00	0.00	0.00	0.00
278-9778-72201-WA2105	DEFINED CONTRIBUTION EXP	747.72	820.28	0.00	0.00	0.00	0.00	0.00
278-9778-72201-WA2205	DEFINED CONTRIBUTION EXP	0.00	2,000.00	0.00	0.00	0.00	0.00	0.00
280-9779-72201	DEFINED CONTRIBUTION EXP	(1,591.00)	0.00	0.00	0.00	0.00	0.00	0.00
281-9666-70600-LH1905	PERMANENT EMPLOYEES	20,729.75	4,578.98	4,578.98	0.00	0.00	4,578.98	0.00
281-9666-72501-LH1905	FEES & PER DIEM	2,251.96	5,054.24	5,054.24	1,690.00	0.00	3,364.24	33.44
281-9666-72502-LH1905	EMPLOYEE FRINGE BENEFITS	8,602.20	14,665.85	14,665.85	0.00	0.00	14,665.85	0.00
281-9666-72503-LH1905	TRANSPORTATION	3,505.60	2,641.35	2,641.35	0.00	0.00	2,641.35	0.00
281-9706-70600-LH1902	PERMANENT EMPLOYEES	19,739.81	233,448.93	233,448.93	0.00	0.00	233,448.93	0.00
281-9706-72502-LH1902	EMPLOYEE FRINGE BENEFITS	5,532.28	164,166.55	164,166.55	0.00	0.00	164,166.55	0.00
494-9494-70300	APPOINTED OFFICIAL	166,096.08	181,160.00	181,160.00	136,118.60	0.00	45,041.40	75.14
494-9494-70703	CLERICAL CO-OP	24,503.80	35,000.00	35,000.00	7,850.00	0.00	27,150.00	22.43
494-9494-70705	TEMPORARY - INSPECTION	28,216.50	75,000.00	75,000.00	23,723.50	0.00	51,276.50	31.63

REVENUE AND EXPENDITURE REPORT

PERIOD ENDING 04/30/2024

% Fiscal Year Completed: 83.33

GL NUMBER	DESCRIPTION	END BALANCE	2023-24		YTD BALANCE	ENCUMBERED	UNENCUMBERED	% BDGT
		06/30/2023	ORIGINAL	2023-24	04/30/2024			
		NORM (ABNORM)	BUDGET	AMENDED BUDGET	NORM (ABNORM)	YEAR-TO-DATE	BALANCE	USED
494-9494-71302	EDUCATION ALLOWANCE	0.00	2,000.00	2,000.00	0.00	0.00	2,000.00	0.00
494-9494-71303	CLEAN/CLOTHING ALLOWANCE	300.00	700.00	700.00	700.00	0.00	0.00	100.00
494-9494-71500	SOCIAL SECURITY	18,005.62	23,673.00	23,673.00	13,690.35	0.00	9,982.65	57.83
494-9494-71900	EMPLOYEE INSURANCES	26,117.73	91,156.00	91,156.00	30,301.71	0.00	60,854.29	33.24
494-9494-71904	RETIREE HEALTH INSURANCE	22,837.00	22,837.00	22,837.00	19,030.00	0.00	3,807.00	83.33
494-9494-71905	H.S.A. EXPENSE	3,726.31	3,989.00	3,989.00	3,003.73	0.00	985.27	75.30
494-9494-71906	SUPPL LIFE INSURANCE EXP	0.00	500.00	500.00	0.00	0.00	500.00	0.00
494-9494-72100	LONGEVITY	3,453.48	7,219.00	7,219.00	2,230.12	0.00	4,988.88	30.89
494-9494-72101	BONUS/SICK REDEMPTION	2,914.80	8,330.00	8,330.00	4,288.70	0.00	4,041.30	51.48
494-9494-72201	DEFINED CONTRIBUTION EXP	18,631.02	19,941.00	19,941.00	15,018.72	0.00	4,922.28	75.32
495-9495-70600	PERMANENT EMPLOYEES	8,335.03	18,000.00	18,000.00	6,848.85	0.00	11,151.15	38.05
495-9495-71900	EMPLOYEE INSURANCES	0.00	6,000.00	6,000.00	1,504.08	0.00	4,495.92	25.07
536-9536-70600	PERMANENT EMPLOYEES	346,715.47	369,117.00	369,117.00	289,560.96	0.00	79,556.04	78.45
536-9536-70700	TEMPORARY EMPLOYEES	0.00	25,000.00	25,000.00	0.00	0.00	25,000.00	0.00
536-9536-70900	OVERTIME	5,922.37	6,000.00	6,000.00	5,380.88	0.00	619.12	89.68
536-9536-71303	CLEAN/CLOTHING ALLOWANCE	1,500.00	1,750.00	1,750.00	1,750.00	0.00	0.00	100.00
536-9536-71500	SOCIAL SECURITY	27,360.84	32,343.00	32,343.00	23,513.22	0.00	8,829.78	72.70
536-9536-71900	EMPLOYEE INSURANCES	96,748.69	112,388.00	112,388.00	91,689.16	0.00	20,698.84	81.58
536-9536-71904	RETIREE HEALTH INSURANCE	26,491.00	22,837.00	22,837.00	19,030.00	0.00	3,807.00	83.33
536-9536-71905	H.S.A. EXPENSE	7,382.64	7,956.00	7,956.00	6,336.69	0.00	1,619.31	79.65
536-9536-71906	SUPPL LIFE INSURANCE EXP	696.00	1,152.00	1,152.00	991.40	0.00	160.60	86.06
536-9536-72100	LONGEVITY	2,029.22	5,612.00	5,612.00	4,857.50	0.00	754.50	86.56
536-9536-72101	BONUS/SICK REDEMPTION	13,018.74	15,239.00	15,239.00	15,237.60	0.00	1.40	99.99
536-9536-72201	DEFINED CONTRIBUTION EXP	36,916.14	39,775.00	39,775.00	31,682.52	0.00	8,092.48	79.65
537-9537-70600	PERMANENT EMPLOYEES	129,743.81	130,448.00	130,448.00	102,949.98	0.00	27,498.02	78.92
537-9537-70700	TEMPORARY EMPLOYEES	12,465.00	25,000.00	25,000.00	7,537.50	0.00	17,462.50	30.15
537-9537-70900	OVERTIME	6,795.91	6,000.00	6,000.00	4,093.88	0.00	1,906.12	68.23
537-9537-71303	CLEAN/CLOTHING ALLOWANCE	900.00	1,050.00	1,050.00	1,050.00	0.00	0.00	100.00
537-9537-71500	SOCIAL SECURITY	11,147.80	12,894.00	12,894.00	8,561.82	0.00	4,332.18	66.40
537-9537-71900	EMPLOYEE INSURANCES	69,964.99	67,586.00	67,586.00	61,633.29	0.00	5,952.71	91.19
537-9537-71905	H.S.A. EXPENSE	2,748.38	2,871.00	2,871.00	2,162.12	0.00	708.88	75.31
537-9537-72101	BONUS/SICK REDEMPTION	0.00	5,999.00	5,999.00	0.00	0.00	5,999.00	0.00
537-9537-72201	DEFINED CONTRIBUTION EXP	13,742.58	14,351.00	14,351.00	10,810.92	0.00	3,540.08	75.33
592-1540-70600	PERMANENT EMPLOYEES	2,252,745.06	2,797,440.00	2,797,440.00	1,775,057.75	0.00	1,022,382.25	63.45
592-1540-70700	TEMPORARY EMPLOYEES	124,318.06	204,880.00	204,880.00	137,306.20	0.00	67,573.80	67.02
592-1540-70900	OVERTIME	158,382.01	120,000.00	120,000.00	106,753.64	0.00	13,246.36	88.96
592-1540-71302	EDUCATION ALLOWANCE	15,382.69	23,500.00	23,500.00	16,223.29	1,135.00	6,141.71	73.87
592-1540-71303	CLEAN/CLOTHING ALLOWANCE	9,900.00	13,300.00	13,300.00	11,929.17	0.00	1,370.83	89.69
592-1540-71500	SOCIAL SECURITY	195,154.08	248,169.00	248,169.00	155,366.94	0.00	92,802.06	62.61
592-1540-71900	EMPLOYEE INSURANCES	780,549.25	902,522.00	902,522.00	436,696.77	0.00	465,825.23	48.39
592-1540-71904	RETIREE HEALTH INSURANCE	423,763.00	365,376.00	365,376.00	304,480.00	0.00	60,896.00	83.33
592-1540-71905	H.S.A. EXPENSE	40,571.11	52,617.00	52,617.00	32,325.72	0.00	20,291.28	61.44
592-1540-71906	SUPPL LIFE INSURANCE EXP	3,654.00	3,654.00	3,654.00	3,184.60	0.00	469.40	87.15
592-1540-72100	LONGEVITY	48,200.03	104,403.00	104,403.00	24,579.07	0.00	79,823.93	23.54
592-1540-72200	RETIREMENT FUND	2,004,834.00	1,260,138.00	1,260,138.00	1,050,120.00	0.00	210,018.00	83.33
592-1540-72201	DEFINED CONTRIBUTION EXP	216,478.28	277,688.00	277,688.00	174,147.64	0.00	103,540.36	62.71
592-1560-70600	PERMANENT EMPLOYEES	1,474,696.39	1,714,992.00	1,714,992.00	1,116,957.61	0.00	598,034.39	65.13
592-1560-70700	TEMPORARY EMPLOYEES	0.00	0.00	0.00	10,416.25	0.00	(10,416.25)	100.00
592-1560-70900	OVERTIME	108,216.37	120,000.00	120,000.00	79,605.99	0.00	40,394.01	66.34
592-1560-71302	EDUCATION ALLOWANCE	8,630.00	10,000.00	10,000.00	12,878.45	0.00	(2,878.45)	128.78
592-1560-71303	CLEAN/CLOTHING ALLOWANCE	6,550.00	7,000.00	7,000.00	6,708.34	0.00	291.66	95.83
592-1560-71500	SOCIAL SECURITY	122,847.62	145,429.00	145,429.00	94,491.00	0.00	50,938.00	64.97
592-1560-71900	EMPLOYEE INSURANCES	349,406.73	372,258.00	372,258.00	190,566.25	0.00	181,691.75	51.19
592-1560-71904	RETIREE HEALTH INSURANCE	185,404.00	159,859.00	159,859.00	133,170.00	0.00	26,689.00	83.30
592-1560-71905	H.S.A. EXPENSE	27,221.24	32,817.00	32,817.00	20,416.83	0.00	12,400.17	62.21
592-1560-71906	SUPPL LIFE INSURANCE EXP	1,633.00	1,692.00	1,692.00	1,392.64	0.00	299.36	82.31
592-1560-72100	LONGEVITY	43,981.68	48,769.00	48,769.00	30,540.60	0.00	18,228.40	62.62
592-1560-72200	RETIREMENT FUND	637,901.00	400,953.00	400,953.00	334,130.00	0.00	66,823.00	83.33

REVENUE AND EXPENDITURE REPORT

PERIOD ENDING 04/30/2024

% Fiscal Year Completed: 83.33

GL NUMBER	DESCRIPTION	END BALANCE	2023-24		YTD BALANCE	ENCUMBERED	UNENCUMBERED	% BDGT
		06/30/2023	ORIGINAL	2023-24	04/30/2024			
		NORM (ABNORM)	BUDGET	AMENDED BUDGET	NORM (ABNORM)	YEAR-TO-DATE	BALANCE	USED
592-1560-72201	DEFINED CONTRIBUTION EXP	162,258.56	191,077.00	191,077.00	123,082.84	0.00	67,994.16	64.42
592-1580-70600	PERMANENT EMPLOYEES	2,976,506.43	3,472,737.00	3,472,737.00	2,437,269.96	0.00	1,035,467.04	70.18
592-1580-70700	TEMPORARY EMPLOYEES	3,135.34	80,000.00	80,000.00	5,835.00	0.00	74,165.00	7.29
592-1580-70900	OVERTIME	229,540.43	275,050.00	275,050.00	232,578.84	0.00	42,471.16	84.56
592-1580-71302	EDUCATION ALLOWANCE	27,657.07	59,500.00	59,500.00	42,274.58	8,050.00	9,175.42	84.58
592-1580-71303	CLEAN/CLOTHING ALLOWANCE	10,729.16	14,350.00	14,350.00	13,241.67	0.00	1,108.33	92.28
592-1580-71308	CERTIFICATION BONUSES	50,808.25	58,000.00	58,000.00	49,000.00	0.00	9,000.00	84.48
592-1580-71500	SOCIAL SECURITY	258,115.32	304,425.00	304,425.00	215,064.29	0.00	89,360.71	70.65
592-1580-71700	HOLIDAY PAY	68,117.68	80,870.00	80,870.00	37,401.42	0.00	43,468.58	46.25
592-1580-71900	EMPLOYEE INSURANCES	877,317.14	934,879.00	934,879.00	477,159.04	0.00	457,719.96	51.04
592-1580-71904	RETIREE HEALTH INSURANCE	662,159.00	570,925.00	570,925.00	475,780.00	0.00	95,145.00	83.33
592-1580-71905	H.S.A. EXPENSE	42,583.05	60,317.00	60,317.00	37,031.84	0.00	23,285.16	61.40
592-1580-71906	SUPPL LIFE INSURANCE EXP	3,658.00	3,658.00	3,658.00	3,688.96	0.00	(30.96)	100.85
592-1580-72100	LONGEVITY	73,587.77	86,352.00	86,352.00	60,713.74	0.00	25,638.26	70.31
592-1580-72200	RETIREMENT FUND	1,093,545.00	687,336.00	687,336.00	572,780.00	0.00	114,556.00	83.33
592-1580-72201	DEFINED CONTRIBUTION EXP	361,452.29	413,078.00	413,078.00	313,999.87	0.00	99,078.13	76.01
Net PERSONNEL SERVICES		152,199,526.21	175,187,776.03	173,843,588.93	126,567,548.39	9,185.00	47,266,855.54	72.81
SUPPLIES								
101-1101-72700	OFFICE SUPPLIES	1,372.00	17,215.00	17,215.00	9,124.97	6,091.38	1,998.65	88.39
101-1136-72700	OFFICE SUPPLIES	104,380.34	110,000.00	110,000.00	84,028.34	29,408.57	(3,436.91)	103.12
101-1136-74006	2020 DOJ CORONAVIRUS CESF - CC	31,315.23	0.00	21,740.00	4,924.50	0.00	16,815.50	22.65
101-1171-72700	OFFICE SUPPLIES	6,203.13	10,000.00	10,000.00	4,796.27	5,691.76	(488.03)	104.88
101-1209-72700	OFFICE SUPPLIES	9,344.36	15,000.00	15,000.00	4,703.48	4,101.78	6,194.74	58.70
101-1210-72700	OFFICE SUPPLIES	10,099.55	24,000.00	24,000.00	20,843.34	2,680.18	476.48	98.01
101-1215-72700	OFFICE SUPPLIES	14,543.32	40,000.00	43,350.00	10,211.81	9,473.01	23,665.18	45.41
101-1220-72700	OFFICE SUPPLIES	8,939.42	14,500.00	14,500.00	7,437.15	3,520.05	3,542.80	75.57
101-1221-72700	OFFICE SUPPLIES	598.51	700.00	700.00	0.00	700.00	0.00	100.00
101-1221-74000	OPERATING SUPPLIES	1,000.00	6,000.00	6,000.00	3,250.00	750.00	2,000.00	66.67
101-1223-72700	OFFICE SUPPLIES	10,434.27	25,000.00	25,000.00	18,420.78	8,576.31	(1,997.09)	107.99
101-1237-72700	OFFICE SUPPLIES	0.00	6,100.00	6,100.00	0.00	0.00	6,100.00	0.00
101-1238-72700	OFFICE SUPPLIES	0.00	5,218.00	5,218.00	0.00	0.00	5,218.00	0.00
101-1253-72700	OFFICE SUPPLIES	9,635.52	21,150.00	21,150.00	10,447.00	3,097.35	7,605.65	64.04
101-1258-74000	OPERATING SUPPLIES	2,358.25	23,740.00	23,740.00	4,339.78	7,951.93	11,448.29	51.78
101-1265-74000	OPERATING SUPPLIES	48,748.53	103,040.00	103,040.00	39,608.99	31,670.00	31,761.01	69.18
101-1265-77600	MAINTENANCE SUPPLIES	51,638.20	114,000.00	114,000.00	25,316.98	45,332.47	43,350.55	61.97
101-1301-72401	UNIFORMS	231,252.41	265,800.00	265,800.00	167,297.00	85,202.08	13,300.92	95.00
101-1301-72700	OFFICE SUPPLIES	52,970.98	157,639.00	157,639.00	47,626.63	21,920.44	88,091.93	44.12
101-1301-74000	OPERATING SUPPLIES	83,985.92	128,049.00	128,049.00	85,524.61	37,584.77	4,939.62	96.14
101-1301-74005	2020 DOJ CORONAVIRUS CESF	53,850.33	0.00	0.00	0.00	0.00	0.00	0.00
101-1301-75100	GAS & OIL	390,536.56	500,000.00	500,000.00	254,092.55	0.00	245,907.45	50.82
101-1311-72700	OFFICE SUPPLIES	299.04	1,000.00	1,000.00	0.00	300.00	700.00	30.00
101-1336-72401	UNIFORMS	94,099.65	110,450.00	119,950.00	92,635.30	10,634.49	16,680.21	86.09
101-1336-72701	EMS MEDICAL SUPPLIES	206,813.70	233,000.00	233,000.00	160,746.32	38,832.39	33,421.29	85.66
101-1336-74000	OPERATING SUPPLIES	407,656.83	410,000.00	430,226.00	377,386.74	169,759.25	(116,919.99)	127.18
101-1336-75100	GAS & OIL	196,784.55	225,000.00	225,000.00	128,691.59	1,407.36	94,901.05	57.82
101-1371-72700	OFFICE SUPPLIES	30,868.99	47,000.00	47,000.00	16,292.84	16,388.90	14,318.26	69.54
101-1400-72700	OFFICE SUPPLIES	11,269.42	18,550.00	18,550.00	10,675.03	6,052.02	1,822.95	90.17
101-1401-72700	OFFICE SUPPLIES	0.00	1,000.00	1,000.00	146.22	0.00	853.78	14.62
101-1410-72700	OFFICE SUPPLIES	301.60	1,470.00	1,470.00	0.00	0.00	1,470.00	0.00
101-1421-72700	OFFICE SUPPLIES	3,241.02	6,300.00	6,300.00	1,720.96	2,784.18	1,794.86	71.51
101-1422-72700	OFFICE SUPPLIES	25,851.21	11,000.00	11,000.00	3,341.51	4,479.35	3,179.14	71.10
101-1422-74000	OPERATING SUPPLIES	0.00	65,000.00	65,000.00	11,683.54	3,948.86	49,367.60	24.05
101-1426-72401	UNIFORMS	750.00	750.00	750.00	750.00	0.00	0.00	100.00
101-1426-74000	OPERATING SUPPLIES	1,378.26	2,500.00	2,500.00	0.00	474.04	2,025.96	18.96
101-1430-72401	UNIFORMS	1,140.00	0.00	0.00	0.00	0.00	0.00	0.00
101-1430-74000	OPERATING SUPPLIES	4,169.46	5,500.00	5,500.00	1,449.11	1,780.89	2,270.00	58.73
101-1442-74000	OPERATING SUPPLIES	135,670.90	410,750.00	410,750.00	76,164.24	104,739.73	229,846.03	44.04

REVENUE AND EXPENDITURE REPORT

PERIOD ENDING 04/30/2024

% Fiscal Year Completed: 83.33

GL NUMBER	DESCRIPTION	END BALANCE	2023-24		YTD BALANCE	ENCUMBERED	UNENCUMBERED	% BDGT
		06/30/2023	ORIGINAL	2023-24	04/30/2024			
		NORM (ABNORM)	BUDGET	AMENDED BUDGET	NORM (ABNORM)	YEAR-TO-DATE	BALANCE	USED
101-1442-75100	GAS & OIL	166,066.03	200,000.00	200,000.00	116,392.54	54,417.39	29,190.07	85.40
101-1447-72700	OFFICE SUPPLIES	15,919.70	42,300.00	43,600.00	20,123.53	12,561.75	10,914.72	74.97
101-1779-72700	OFFICE SUPPLIES	2.64	100.00	100.00	44.80	0.00	55.20	44.80
101-1780-72700	OFFICE SUPPLIES	0.00	300.00	300.00	0.00	0.00	300.00	0.00
101-1780-74000	OPERATING SUPPLIES	776.16	1,500.00	1,500.00	160.00	0.00	1,340.00	10.67
101-1793-72700	OFFICE SUPPLIES	55.09	500.00	500.00	43.48	350.00	106.52	78.70
101-1794-72700	OFFICE SUPPLIES	0.00	100.00	100.00	0.00	0.00	100.00	0.00
101-1795-72700	OFFICE SUPPLIES	303.91	1,520.00	1,520.00	54.00	646.00	820.00	46.05
101-1796-72700	OFFICE SUPPLIES	100.00	600.00	600.00	0.00	0.00	600.00	0.00
101-1797-74000	OPERATING SUPPLIES	0.00	1,000.00	1,000.00	0.00	0.00	1,000.00	0.00
202-2463-77600	MAINTENANCE SUPPLIES	36,282.08	150,000.00	150,000.00	30,917.78	1,250.00	117,832.22	21.45
202-2474-78601	TRAFFIC & STREET SIGNS	1,771.00	5,000.00	5,000.00	1,668.49	0.00	3,331.51	33.37
202-2479-77600	MAINTENANCE SUPPLIES	183,831.01	315,000.00	315,000.00	146,097.84	0.00	168,902.16	46.38
203-3463-77600	MAINTENANCE SUPPLIES	43,868.38	175,000.00	175,000.00	38,714.49	0.00	136,285.51	22.12
203-3474-78601	TRAFFIC & STREET SIGNS	2,302.99	5,000.00	5,000.00	2,355.50	0.00	2,644.50	47.11
203-3479-77600	MAINTENANCE SUPPLIES	54,446.96	255,000.00	255,000.00	59,037.37	0.00	195,962.63	23.15
208-9208-72700	OFFICE SUPPLIES	3,672.56	8,000.00	8,000.00	3,381.64	994.55	3,623.81	54.70
208-9208-72703	BINGO OPERATING SUPPLIES	0.00	200.00	200.00	0.00	0.00	200.00	0.00
208-9208-74000	OPERATING SUPPLIES	10,064.62	10,000.00	10,000.00	2,511.00	0.56	7,488.44	25.12
208-9208-76000	PLAYGROUND & ATH SUPPLIES	49,667.14	60,000.00	60,000.00	24,845.94	15,847.96	19,306.10	67.82
208-9208-77600	MAINTENANCE SUPPLIES	94,525.24	125,000.00	125,000.00	64,883.48	33,535.96	26,580.56	78.74
208-9210-72700	OFFICE SUPPLIES	579.00	2,000.00	2,000.00	0.00	0.00	2,000.00	0.00
208-9210-74000	OPERATING SUPPLIES	0.00	2,000.00	2,000.00	0.00	0.00	2,000.00	0.00
226-9226-72700	OFFICE SUPPLIES	14,082.28	15,000.00	15,000.00	3,680.11	3,802.93	7,516.96	49.89
226-9226-74000	OPERATING SUPPLIES	0.00	0.00	65,000.00	4,734.31	13,479.19	46,786.50	28.02
226-9226-75100	GAS & OIL	481,676.50	550,000.00	550,000.00	291,646.64	185,857.47	72,495.89	86.82
230-9230-72700	OFFICE SUPPLIES	9,331.47	12,300.00	12,300.00	7,436.95	3,969.99	893.06	92.74
250-9250-72700	OFFICE SUPPLIES	1,449.92	3,500.00	3,500.00	870.83	280.93	2,348.24	32.91
250-9250-74000	OPERATING SUPPLIES	15,753.29	20,000.00	23,570.00	17,856.40	909.31	4,804.29	79.62
250-9250-74001	TAPES	1,989.96	2,000.00	2,000.00	699.00	0.00	1,301.00	34.95
259-9259-72700	OFFICE SUPPLIES	3,078.01	0.00	4,200.00	2,754.34	94.56	1,351.10	67.83
271-9271-72700	OFFICE SUPPLIES	58,320.67	97,600.00	97,600.00	45,370.29	26,465.39	25,764.32	73.60
271-9271-72702	COPY MACHINE EXPENSE	8,976.24	20,000.00	20,000.00	5,244.37	7,396.25	7,359.38	63.20
273-9666-72700-CD1713	OFFICE SUPPLIES	0.00	468.99	0.00	0.00	0.00	0.00	0.00
273-9666-72700-CD1812	OFFICE SUPPLIES	0.00	958.35	0.00	0.00	0.00	0.00	0.00
273-9666-72700-CD2115	OFFICE SUPPLIES	368.00	627.05	0.00	0.00	0.00	0.00	0.00
273-9666-72700-CD2213	OFFICE SUPPLIES	118.84	2,881.16	0.00	0.00	0.00	0.00	0.00
273-9666-72702-CD1713	COPY MACHINE EXPENSE	0.00	790.36	0.00	0.00	0.00	0.00	0.00
273-9666-72702-CD1812	COPY MACHINE EXPENSE	0.00	357.63	0.00	0.00	0.00	0.00	0.00
273-9666-72702-CD1912	COPY MACHINE EXPENSE	0.00	933.60	0.00	0.00	0.00	0.00	0.00
273-9666-72702-CD2015	COPY MACHINE EXPENSE	0.00	208.13	0.00	0.00	0.00	0.00	0.00
273-9666-72702-CD2115	COPY MACHINE EXPENSE	223.56	271.80	0.00	0.00	0.00	0.00	0.00
273-9666-72702-CD2213	COPY MACHINE EXPENSE	1,216.31	0.00	0.00	0.00	0.00	0.00	0.00
277-9777-72700-HM2105	OFFICE SUPPLIES	0.00	500.00	500.00	0.00	0.00	500.00	0.00
277-9777-72700-HM2204	OFFICE SUPPLIES	0.00	500.00	500.00	0.00	0.00	500.00	0.00
281-9666-72700-LH1905	OFFICE SUPPLIES	193.00	1,033.15	1,033.15	0.00	0.00	1,033.15	0.00
494-9494-72700	OFFICE SUPPLIES	0.00	3,000.00	3,000.00	0.00	0.00	3,000.00	0.00
495-9495-72700	OFFICE SUPPLIES	0.00	500.00	500.00	0.00	0.00	500.00	0.00
536-9536-72700	OFFICE SUPPLIES	1,397.30	2,000.00	2,000.00	268.60	1,681.40	50.00	97.50
536-9536-76001	PROGRAM ACTIVITY SUPPLIES	1,344.15	2,000.00	2,000.00	372.31	306.76	1,320.93	33.95
536-9536-77600	MAINTENANCE SUPPLIES	12,087.53	10,000.00	10,000.00	8,885.98	4,635.12	(3,521.10)	135.21
537-9537-72700	OFFICE SUPPLIES	2,720.46	12,000.00	12,000.00	1,075.30	6,015.70	4,909.00	59.09
537-9537-76001	PROGRAM ACTIVITY SUPPLIES	3,015.91	6,000.00	6,000.00	1,208.41	920.31	3,871.28	35.48
537-9537-77600	MAINTENANCE SUPPLIES	32,646.89	30,000.00	30,000.00	14,513.07	4,971.19	10,515.74	64.95
592-1540-72401	UNIFORMS	(345.28)	0.00	0.00	0.00	0.00	0.00	0.00
592-1540-74000	OPERATING SUPPLIES	427,366.81	484,000.00	484,000.00	282,482.04	392,244.37	(190,726.41)	139.41
592-1540-78700	MATERIALS	333,188.87	100,000.00	100,000.00	94,029.24	0.00	5,970.76	94.03
592-1540-78900	METER REPLACEMENT	51,191.33	242,000.00	242,000.00	114,272.96	0.00	127,727.04	47.22

REVENUE AND EXPENDITURE REPORT

PERIOD ENDING 04/30/2024

% Fiscal Year Completed: 83.33

GL NUMBER	DESCRIPTION	END BALANCE	2023-24		YTD BALANCE	ENCUMBERED	UNENCUMBERED	% BDGT
		06/30/2023	ORIGINAL	2023-24	04/30/2024			
		NORM (ABNORM)	BUDGET	AMENDED BUDGET	NORM (ABNORM)	YEAR-TO-DATE	BALANCE	USED
592-1560-72401	UNIFORMS	(31.39)	0.00	0.00	0.00	0.00	0.00	0.00
592-1560-74000	OPERATING SUPPLIES	9,407.13	10,000.00	10,000.00	7,183.44	18,897.78	(16,081.22)	260.81
592-1580-72401	UNIFORMS	(303.42)	0.00	0.00	0.00	0.00	0.00	0.00
592-1580-74000	OPERATING SUPPLIES	51,680.91	70,000.00	70,000.00	25,592.82	17,742.97	26,664.21	61.91
592-1580-74300	CHEMICALS	191,419.51	300,000.00	300,000.00	197,239.21	136,386.02	(33,625.23)	111.21
Net SUPPLIES		4,621,300.73	6,497,971.22	6,619,360.15	3,322,326.08	1,610,995.35	1,686,038.72	74.53
OTHER SERVICES & CHARGES								
101-1101-80100	CONTRACTUAL SERVICES	398,050.15	425,000.00	425,000.00	213,389.34	44,805.74	166,804.92	60.75
101-1101-80102	COURT REPORTER	0.00	1,200.00	1,200.00	0.00	0.00	1,200.00	0.00
101-1101-80200	POSTAGE	250.53	1,300.00	1,300.00	666.24	0.00	633.76	51.25
101-1101-85300	TELEPHONE & RADIO	441.60	1,100.00	1,100.00	262.70	0.00	837.30	23.88
101-1101-86100	MILEAGE	0.00	450.00	450.00	0.00	0.00	450.00	0.00
101-1101-90000	PRINTING & PUBLISHING	590.50	3,500.00	3,500.00	3,415.50	0.00	84.50	97.59
101-1136-80008	PAID STATE OF MICHIGAN	21,347.71	45,000.00	45,000.00	23,711.10	0.00	21,288.90	52.69
101-1136-80100	CONTRACTUAL SERVICES	86,529.40	138,200.00	138,200.00	102,440.98	20,346.53	15,412.49	88.85
101-1136-80103	CONT SERV/MAGIST/VIST JUD	111,816.06	82,500.00	82,500.00	60,642.10	0.00	21,857.90	73.51
101-1136-80137	CONT SERV - DATA PROC	261,472.25	356,450.00	422,234.00	84,098.27	65,784.00	272,351.73	35.50
101-1136-80200	POSTAGE	20,451.46	122,000.00	122,000.00	93,525.49	1,210.40	27,264.11	77.65
101-1136-80202	BANK SERVICE CHARGES	15,817.85	16,000.00	16,000.00	10,730.12	0.00	5,269.88	67.06
101-1136-81900	TRANSCRIPTS	0.00	650.00	650.00	0.00	0.00	650.00	0.00
101-1136-82210	DRUG COURT GRANT EXPENSE	5,909.83	15,000.00	15,000.00	5,174.20	3,820.49	6,005.31	59.96
101-1136-82244	SUBSTANCE ABUSE GRT FY22 EXP	77,773.82	0.00	0.00	0.00	0.00	0.00	0.00
101-1136-82245	MICH DRUG COURT GRT FY22 EXP	6,408.59	0.00	0.00	0.00	0.00	0.00	0.00
101-1136-82246	SUBSTANCE ABUSE GRT FY23 EXP	153,231.80	0.00	141,656.00	42,473.33	0.00	99,182.67	29.98
101-1136-82247	MICH DRUG COURT GRT FY23 EXP	44,760.12	0.00	45,240.00	12,823.00	0.00	32,417.00	28.34
101-1136-82248	SUBSTANCE ABUSE GRT FY 24 EXP	0.00	0.00	305,698.00	105,426.47	57,351.21	142,920.32	53.25
101-1136-82249	MICH DRUG COURT GRT FY24 EXP	0.00	0.00	23,000.00	9,416.00	9,334.05	4,249.95	81.52
101-1136-83500	WITNESS & JURY FEES	13,382.20	15,000.00	15,000.00	6,405.20	0.00	8,594.80	42.70
101-1136-85300	TELEPHONE & RADIO	37,485.11	40,735.00	40,735.00	27,695.91	1,471.60	11,567.49	71.60
101-1136-86100	MILEAGE	186.46	1,700.00	1,700.00	220.74	0.00	1,479.26	12.98
101-1136-88001	COMMUNITY PROMOTION/OUTREACH F	0.00	500.00	500.00	0.00	0.00	500.00	0.00
101-1136-92000	PUBLIC UTILITIES	105,255.73	110,000.00	110,000.00	80,455.12	0.00	29,544.88	73.14
101-1136-94200	BUILDING RENTAL	250,000.00	250,000.00	250,000.00	250,000.00	0.00	0.00	100.00
101-1136-95800	MEMBERSHIPS & DUES	9,104.70	12,240.00	12,240.00	10,481.35	140.30	1,618.35	86.78
101-1136-96259	TRANSFER TO INDIGENT DEFENSE	123,769.06	135,000.00	135,000.00	123,769.06	0.00	11,230.94	91.68
101-1171-80100	CONTRACTUAL SERVICES	5,272.49	6,500.00	6,500.00	4,229.21	2,270.03	0.76	99.99
101-1171-80200	POSTAGE	2,039.69	5,000.00	5,000.00	1,367.57	0.00	3,632.43	27.35
101-1171-85300	TELEPHONE & RADIO	0.00	0.00	0.00	240.36	0.00	(240.36)	100.00
101-1171-95801	US CONFERENCE OF MAYORS	9,276.00	13,000.00	13,000.00	0.00	0.00	13,000.00	0.00
101-1209-80106	SOFTWARE SERVICES	34,045.67	41,000.00	41,000.00	33,836.97	2,547.96	4,615.07	88.74
101-1209-80200	POSTAGE	34,606.00	34,300.00	34,300.00	36,875.11	0.00	(2,575.11)	107.51
101-1209-80401	BOARD OF REVIEW	2,917.50	7,000.00	7,000.00	2,767.50	182.50	4,050.00	42.14
101-1209-82602	PROFESSIONAL SERVICES	79,382.00	190,000.00	190,000.00	30,615.44	113,266.50	46,118.06	75.73
101-1209-83300	TAX ROLL PREPARATION	15,968.94	35,000.00	35,000.00	12,604.65	2,394.29	20,001.06	42.85
101-1209-85300	TELEPHONE & RADIO	75.00	250.00	250.00	0.00	0.00	250.00	0.00
101-1209-86300	VEHICLE MAINTENANCE	1,127.03	2,000.00	2,000.00	667.95	445.25	886.80	55.66
101-1209-95800	MEMBERSHIPS & DUES	3,526.39	7,000.00	7,000.00	3,255.00	0.00	3,745.00	46.50
101-1210-80100	CONTRACTUAL SERVICES	22,058.21	13,600.00	19,700.00	12,824.38	3,483.91	3,391.71	82.78
101-1210-80200	POSTAGE	727.35	1,700.00	1,700.00	616.17	0.00	1,083.83	36.25
101-1210-82600	LEGAL FEES	2,285.85	14,000.00	14,000.00	3,868.77	498.98	9,632.25	31.20
101-1210-86100	MILEAGE	254.14	700.00	700.00	0.00	0.00	700.00	0.00
101-1210-95800	MEMBERSHIPS & DUES	34,794.72	42,000.00	42,000.00	23,477.73	12,130.67	6,391.60	84.78
101-1215-80100	CONTRACTUAL SERVICES	18,228.21	64,900.00	64,900.00	15,920.65	7,510.84	41,468.51	36.10
101-1215-80200	POSTAGE	49,200.75	114,000.00	144,000.00	48,828.71	0.00	95,171.29	33.91
101-1215-80400	ELECTION WAGES	175,170.00	629,425.00	691,355.00	269,032.45	0.00	422,322.55	38.91
101-1215-80600	ELECTION EXPENSE	121,767.00	398,900.00	551,800.00	241,771.51	154,909.73	155,118.76	71.89
101-1215-86300	VEHICLE MAINTENANCE	757.31	2,000.00	2,000.00	766.42	0.00	1,233.58	38.32

REVENUE AND EXPENDITURE REPORT

PERIOD ENDING 04/30/2024

% Fiscal Year Completed: 83.33

GL NUMBER	DESCRIPTION	END BALANCE	2023-24		YTD BALANCE	ENCUMBERED	UNENCUMBERED	% BDGT
		06/30/2023	ORIGINAL	2023-24	04/30/2024			
		NORM (ABNORM)	BUDGET	AMENDED BUDGET	NORM (ABNORM)	YEAR-TO-DATE	BALANCE	USED
101-1215-90000	PRINTING & PUBLISHING	26,634.42	50,000.00	51,418.00	27,685.95	6,474.05	17,258.00	66.44
101-1215-93000	BUILDING MAINTENANCE	0.00	4,000.00	4,000.00	0.00	500.00	3,500.00	12.50
101-1220-80100	CONTRACTUAL SERVICES	76,556.73	198,800.00	198,800.00	52,375.22	42,973.34	103,451.44	47.96
101-1220-80114	ARBITRATION EXPENSE	5,880.78	50,000.00	50,000.00	2,953.84	0.00	47,046.16	5.91
101-1220-80127	CONTRACTUAL SVCS - E.A.C.	23,421.30	27,000.00	27,000.00	0.00	0.00	27,000.00	0.00
101-1220-80200	POSTAGE	1,867.75	2,000.00	2,000.00	1,197.14	171.14	631.72	68.41
101-1220-82800	MEDICAL SERVICES	95,417.00	160,000.00	160,000.00	78,952.00	0.00	81,048.00	49.35
101-1220-90000	PRINTING & PUBLISHING	49,493.36	79,000.00	79,000.00	27,388.08	30,856.32	20,755.60	73.73
101-1220-95800	MEMBERSHIPS & DUES	753.00	1,500.00	1,500.00	0.00	0.00	1,500.00	0.00
101-1221-80100	CONTRACTUAL SERVICES	8,951.94	20,000.00	20,000.00	3,853.81	10,146.19	6,000.00	70.00
101-1221-80200	POSTAGE	30.75	200.00	200.00	52.94	0.00	147.06	26.47
101-1223-80100	CONTRACTUAL SERVICES	1,092.48	17,000.00	17,000.00	4,276.73	478.56	12,244.71	27.97
101-1223-80200	POSTAGE	803.02	1,000.00	1,000.00	708.40	0.00	291.60	70.84
101-1237-80200	POSTAGE	744.05	2,000.00	2,000.00	1,637.89	0.00	362.11	81.89
101-1237-85300	TELEPHONE & RADIO	570.00	1,000.00	1,000.00	446.87	0.00	553.13	44.69
101-1237-96904	REIMB ACT 55	(177,031.57)	(208,917.00)	(208,917.00)	(98,531.46)	0.00	(110,385.54)	47.16
101-1237-96905	VEBA REIMBURSEMENT	(8,899,273.20)	(9,783,211.00)	(9,783,211.00)	(4,696,093.05)	0.00	(5,087,117.95)	48.00
101-1237-96910	MEDICARE REIMBURSEMENT	1,037,127.10	1,150,000.00	1,150,000.00	495,242.80	0.00	654,757.20	43.06
101-1238-80200	POSTAGE	796.09	5,016.00	5,016.00	688.71	0.00	4,327.29	13.73
101-1238-85300	TELEPHONE & RADIO	427.52	1,000.00	1,000.00	335.15	0.00	664.85	33.52
101-1238-96904	REIMB ACT 55	(474,531.58)	(534,726.00)	(550,126.00)	(248,771.85)	0.00	(301,354.15)	45.22
101-1238-96905	VEBA REIMBURSEMENT	(10,160,185.17)	(11,500,000.00)	(11,500,000.00)	(5,630,186.57)	0.00	(5,869,813.43)	48.96
101-1238-96910	MEDICARE REIMBURSEMENT	927,560.40	1,000,000.00	1,000,000.00	494,564.20	0.00	505,435.80	49.46
101-1253-80100	CONTRACTUAL SERVICES	32,773.34	45,545.00	45,545.00	30,797.66	4,122.00	10,625.34	76.67
101-1253-80200	POSTAGE	58,953.59	84,000.00	84,000.00	69,442.86	0.00	14,557.14	82.67
101-1253-83600	TAX STATEMENT PREPARATION	14,768.50	16,000.00	16,000.00	14,494.26	1,256.28	249.46	98.44
101-1258-80100	CONTRACTUAL SERVICES	211,675.75	452,800.00	482,000.00	198,880.91	22,520.72	260,598.37	45.93
101-1258-80106	SOFTWARE SERVICES	26,045.60	27,500.00	27,500.00	305.60	0.00	27,194.40	1.11
101-1265-80110	CONTRACTUAL SERVICES-BLDG MNT	145,911.12	214,650.00	214,650.00	128,856.14	54,262.73	31,531.13	85.31
101-1265-85300	TELEPHONE & RADIO	421.20	1,110.00	1,110.00	0.00	0.00	1,110.00	0.00
101-1265-86300	VEHICLE MAINTENANCE	6,343.60	10,000.00	10,000.00	3,651.84	0.00	6,348.16	36.52
101-1294-80104	CONT SVC- DATA CONVERSION	80,500.00	0.00	774,965.00	229,520.00	545,445.00	0.00	100.00
101-1294-80105	INDEPENDENT AUDIT	91,500.00	99,400.00	99,400.00	94,400.00	0.00	5,000.00	94.97
101-1294-80194	TAX REVERTED PROPERTY	16,372.57	850,000.00	850,000.00	6,538.33	0.00	843,461.67	0.77
101-1294-80301	UNEMPLOYMENT COSTS	0.00	1,250.00	1,250.00	13.91	0.00	1,236.09	1.11
101-1294-82602	PROFESSIONAL SERVICES	639,985.04	522,273.00	710,273.00	350,203.70	122,342.38	237,726.92	66.53
101-1294-85300	TELEPHONE & RADIO	29,176.92	80,000.00	80,000.00	23,475.75	0.00	56,524.25	29.34
101-1294-86400	CONFERENCES & WORKSHOPS	38,977.29	40,000.00	40,000.00	40,978.55	0.00	(978.55)	102.45
101-1294-86401	INCOMING MAYOR TRANSITION EXPE	0.00	15,000.00	15,000.00	15,000.00	0.00	0.00	100.00
101-1294-91000	INSURANCE & BONDS	2,877,281.72	3,300,000.00	3,300,000.00	3,285,772.03	4,323.46	9,904.51	99.70
101-1294-91200	GRIEVANCE SETTLEMENTS	250,000.00	250,000.00	250,000.00	250,000.00	0.00	0.00	100.00
101-1294-91304	401(A) BOARD OPERATING EX	55,412.50	57,000.00	58,675.00	42,912.38	0.00	15,762.62	73.14
101-1294-92001	PUBLIC UTILITIES - COURT	10,409.87	15,000.00	15,000.00	7,957.10	0.00	7,042.90	53.05
101-1294-92002	PUB UTILITIES-CIVIC CENTR	288,609.09	295,000.00	295,000.00	217,258.59	0.00	77,741.41	73.65
101-1294-96701	TRANSFER TO REVOLVING FND	500,000.00	0.00	0.00	0.00	0.00	0.00	0.00
101-1301-80100	CONTRACTUAL SERVICES	860,330.15	703,461.00	732,961.00	408,105.23	97,414.04	227,441.73	68.97
101-1301-80200	POSTAGE	5,800.61	7,000.00	7,000.00	4,628.83	0.00	2,371.17	66.13
101-1301-81001	SPECIAL INVESTIGATIONS	8,000.00	10,000.00	10,000.00	8,000.00	0.00	2,000.00	80.00
101-1301-81200	PRISONER FOOD	23,045.58	60,000.00	60,000.00	31,311.88	11,013.28	17,674.84	70.54
101-1301-81300	CRIME PREVENTION	4,116.30	25,000.00	25,000.00	4,615.70	0.00	20,384.30	18.46
101-1301-82401	INSTRUCTION	61,917.37	97,715.00	97,715.00	71,236.75	15,850.00	10,628.25	89.12
101-1301-82402	911 DISPATCH TRAINING EXP	46,283.50	37,500.00	37,500.00	3,536.00	2,750.00	31,214.00	16.76
101-1301-85300	TELEPHONE & RADIO	112,475.80	276,622.00	277,622.00	24,934.34	18,224.75	234,462.91	15.55
101-1301-86300	VEHICLE MAINTENANCE	26,275.69	26,250.00	33,750.00	15,784.89	10,882.70	7,082.41	79.02
101-1301-88001	COMMUNITY PROMOTION/OUTREACH F	8,441.91	8,500.00	8,500.00	2,188.28	450.00	5,861.72	31.04
101-1301-88002	EXPLORERS	4,967.00	5,000.00	5,000.00	0.00	5,000.00	0.00	100.00
101-1301-88003	YOUTH ATHLETIC LEAGUE	10,000.00	10,000.00	10,000.00	8,348.25	0.00	1,651.75	83.48
101-1301-88004	WELLNESS PROGRAM	0.00	8,000.00	8,000.00	0.00	0.00	8,000.00	0.00

REVENUE AND EXPENDITURE REPORT

PERIOD ENDING 04/30/2024

% Fiscal Year Completed: 83.33

GL NUMBER	DESCRIPTION	END BALANCE	2023-24		YTD BALANCE	ENCUMBERED	UNENCUMBERED	% BDGT
		06/30/2023	ORIGINAL	2023-24	04/30/2024			
		NORM (ABNORM)	BUDGET	AMENDED BUDGET	NORM (ABNORM)	YEAR-TO-DATE	BALANCE	USED
101-1301-88012	CERT EXPENSES	7,454.66	7,500.00	7,500.00	400.10	0.00	7,099.90	5.33
101-1301-92000	PUBLIC UTILITIES	212,220.25	0.00	225,000.00	159,764.94	0.00	65,235.06	71.01
101-1301-93000	BUILDING MAINTENANCE	73,793.76	62,450.00	112,450.00	53,149.63	47,673.90	11,626.47	89.66
101-1301-99400	LEASE PRINCIPAL	94,741.44	94,742.00	94,742.00	94,741.44	0.00	0.56	100.00
101-1311-80100	CONTRACTUAL SERVICES	2,100.00	1,800.00	1,800.00	1,200.00	600.00	0.00	100.00
101-1311-88001	COMMUNITY PROMOTION/OUTREACH F	9,780.31	10,000.00	10,000.00	3,022.57	5,492.63	1,484.80	85.15
101-1311-92000	PUBLIC UTILITIES	2,171.06	2,000.00	2,000.00	1,267.04	0.00	732.96	63.35
101-1336-80100	CONTRACTUAL SERVICES	396,411.79	596,021.00	618,686.00	365,575.34	105,224.67	147,885.99	76.10
101-1336-80101	FIRE PREVENTION WEEK	33,691.50	60,200.00	60,200.00	38,368.14	13,864.95	7,966.91	86.77
101-1336-82401	INSTRUCTION	141,226.45	386,100.00	556,600.00	248,889.89	108,121.12	199,588.99	64.14
101-1336-82800	MEDICAL SERVICES	11,849.00	58,500.00	58,500.00	405.34	16,861.00	41,233.66	29.52
101-1336-85300	TELEPHONE & RADIO	84,888.10	86,000.00	106,000.00	58,529.96	7,349.42	40,120.62	62.15
101-1336-92000	PUBLIC UTILITIES	141,845.49	160,000.00	160,000.00	103,380.72	0.00	56,619.28	64.61
101-1336-93000	BUILDING MAINTENANCE	210,904.53	406,000.00	406,000.00	159,476.43	266,484.10	(19,960.53)	104.92
101-1336-93100	HYDRANT INST & REPAIR	30,000.00	30,000.00	30,000.00	25,000.00	0.00	5,000.00	83.33
101-1336-94100	PUBLIC FIRE PROTECTION	60,000.00	60,000.00	60,000.00	50,000.00	0.00	10,000.00	83.33
101-1336-95800	MEMBERSHIPS & DUES	2,751.20	31,070.00	31,070.00	9,270.37	750.00	21,049.63	32.25
101-1371-80100	CONTRACTUAL SERVICES	66,542.86	204,000.00	204,000.00	92,271.85	18,002.04	93,726.11	54.06
101-1371-80106	SOFTWARE SERVICES	4,968.43	14,800.00	14,800.00	0.00	700.00	14,100.00	4.73
101-1371-80141	TITLE SEARCH	5,820.00	12,000.00	12,000.00	2,405.00	3,595.00	6,000.00	50.00
101-1371-80142	NUISANCE ABATE-DEMOL EXP	0.00	25,000.00	25,000.00	0.00	0.00	25,000.00	0.00
101-1371-80200	POSTAGE	5,223.27	15,000.00	15,000.00	3,135.35	0.00	11,864.65	20.90
101-1371-85300	TELEPHONE & RADIO	2,597.93	19,775.00	19,775.00	899.68	0.00	18,875.32	4.55
101-1371-86300	VEHICLE MAINTENANCE	18,655.68	37,000.00	37,000.00	10,916.69	643.75	25,439.56	31.24
101-1400-80100	CONTRACTUAL SERVICES	9,000.00	141,200.00	311,200.00	6,800.00	63,375.00	241,025.00	22.55
101-1400-80200	POSTAGE	4,488.27	8,000.00	8,000.00	3,964.64	0.00	4,035.36	49.56
101-1400-86300	VEHICLE MAINTENANCE	125.03	1,000.00	1,000.00	0.00	0.00	1,000.00	0.00
101-1400-90000	PRINTING & PUBLISHING	7,265.58	16,000.00	16,000.00	1,275.00	1,725.00	13,000.00	18.75
101-1400-95800	MEMBERSHIPS & DUES	18,913.00	20,950.00	20,950.00	19,826.00	0.00	1,124.00	94.63
101-1401-80200	POSTAGE	3.52	2,500.00	2,500.00	45.47	0.00	2,454.53	1.82
101-1401-86300	VEHICLE MAINTENANCE	1,291.61	1,500.00	1,500.00	22.50	0.00	1,477.50	1.50
101-1401-90000	PRINTING & PUBLISHING	641.00	5,000.00	5,000.00	1,731.84	3,239.85	28.31	99.43
101-1401-95800	MEMBERSHIPS & DUES	1,985.00	3,000.00	3,000.00	0.00	0.00	3,000.00	0.00
101-1401-95808	8 MILE BOULEVARD ASSOC DUES	0.00	7,200.00	7,200.00	6,700.00	0.00	500.00	93.06
101-1410-80102	COURT REPORTER	165.00	3,000.00	3,000.00	0.00	0.00	3,000.00	0.00
101-1410-80200	POSTAGE	2,314.43	6,000.00	6,000.00	1,962.56	0.00	4,037.44	32.71
101-1410-90000	PRINTING & PUBLISHING	0.00	840.00	840.00	0.00	0.00	840.00	0.00
101-1421-80200	POSTAGE	1,103.19	2,000.00	2,000.00	972.88	0.00	1,027.12	48.64
101-1421-85300	TELEPHONE & RADIO	989.32	1,567.00	1,567.00	720.22	0.00	846.78	45.96
101-1421-86300	VEHICLE MAINTENANCE	0.00	600.00	600.00	0.00	0.00	600.00	0.00
101-1422-80107	WEED MOWING	171,561.00	350,000.00	350,000.00	158,096.00	93,000.00	98,904.00	71.74
101-1422-80108	RODENT CONTROL	354,620.00	375,000.00	375,000.00	256,266.00	98,734.00	20,000.00	94.67
101-1422-80200	POSTAGE	2,376.71	5,000.00	5,000.00	1,592.47	0.00	3,407.53	31.85
101-1422-82216	WEST NILE VIRUS EXPENSE	0.00	10,000.00	10,000.00	0.00	0.00	10,000.00	0.00
101-1422-82217	WILDLIFE NUISANCE CONTROL	0.00	20,000.00	20,000.00	0.00	0.00	20,000.00	0.00
101-1422-85300	TELEPHONE & RADIO	3,576.26	4,450.00	4,450.00	2,750.82	0.00	1,699.18	61.82
101-1422-86300	VEHICLE MAINTENANCE	47,049.39	50,000.00	50,000.00	25,321.75	0.00	24,678.25	50.64
101-1422-90000	PRINTING & PUBLISHING	3,909.00	20,000.00	20,000.00	1,340.00	1,323.00	17,337.00	13.32
101-1422-92000	PUBLIC UTILITIES	0.00	1,500.00	1,500.00	4,268.39	0.00	(2,768.39)	284.56
101-1426-80100	CONTRACTUAL SERVICES	11,775.25	15,000.00	15,000.00	7,265.00	235.00	7,500.00	50.00
101-1426-92000	PUBLIC UTILITIES	1,300.90	1,600.00	1,600.00	1,149.60	0.00	450.40	71.85
101-1430-80500	ANIMAL COLLECTION	95,018.09	135,500.00	135,500.00	70,452.05	44,771.45	20,276.50	85.04
101-1430-86300	VEHICLE MAINTENANCE	3,000.00	3,500.00	6,000.00	3,808.38	0.00	2,191.62	63.47
101-1442-80100	CONTRACTUAL SERVICES	249,560.26	1,509,300.00	1,509,300.00	142,028.19	20,107.15	1,347,164.66	10.74
101-1442-81400	TREE MAINTENANCE	919,817.30	1,000,000.00	1,000,000.00	303,955.14	252,255.08	443,789.78	55.62
101-1442-85300	TELEPHONE & RADIO	6,817.47	19,000.00	19,000.00	6,126.23	99.29	12,774.48	32.77
101-1442-86300	VEHICLE MAINTENANCE	997,315.05	1,750,000.00	1,750,000.00	744,861.98	314,773.38	690,364.64	60.55
101-1442-92000	PUBLIC UTILITIES	92,847.16	140,000.00	140,000.00	61,015.39	0.00	78,984.61	43.58

REVENUE AND EXPENDITURE REPORT

PERIOD ENDING 04/30/2024

% Fiscal Year Completed: 83.33

GL NUMBER	DESCRIPTION	END BALANCE	2023-24		YTD BALANCE	ENCUMBERED	UNENCUMBERED	% BDGT
		06/30/2023	ORIGINAL	2023-24	04/30/2024			
		NORM (ABNORM)	BUDGET	AMENDED BUDGET	NORM (ABNORM)	YEAR-TO-DATE	BALANCE	USED
101-1442-93000	BUILDING MAINTENANCE	17,989.36	314,500.00	314,500.00	14,468.75	29,613.70	270,417.55	14.02
101-1442-96202	CONTRIB TO MAJOR STREETS	0.00	76,905.00	76,905.00	0.00	0.00	76,905.00	0.00
101-1442-96203	CONTRIB TO LOCAL STREETS	0.00	106,905.00	106,905.00	0.00	0.00	106,905.00	0.00
101-1447-80100	CONTRACTUAL SERVICES	259,349.10	240,000.00	240,000.00	100,179.54	200.00	139,620.46	41.82
101-1447-80106	SOFTWARE SERVICES	6,193.00	23,500.00	33,500.00	10,702.52	2,700.00	20,097.48	40.01
101-1447-80119	CONT SERV - INSPECTORS	33,755.45	374,000.00	330,895.00	29,784.77	9,167.19	291,943.04	11.77
101-1447-80200	POSTAGE	596.13	800.00	800.00	412.25	0.00	387.75	51.53
101-1447-85300	TELEPHONE & RADIO	579.94	500.00	1,620.00	1,062.45	0.00	557.55	65.58
101-1447-86300	VEHICLE MAINTENANCE	21,371.59	25,000.00	25,000.00	13,010.59	143.00	11,846.41	52.61
101-1447-95800	MEMBERSHIPS & DUES	8,094.90	13,250.00	13,250.00	8,119.90	0.00	5,130.10	61.28
101-1447-96592	TRANSFER TO WATER & SEWER	159,530.00	165,923.00	165,923.00	138,270.00	0.00	27,653.00	83.33
101-1448-92600	STREET LIGHTING	2,967,447.36	3,300,000.00	3,300,000.00	2,455,638.59	5,000.00	839,361.41	74.56
101-1610-88001	COMMUNITY PROMOTION/OUTREACH F	745.02	2,000.00	2,000.00	637.53	0.00	1,362.47	31.88
101-1779-96137	APPRECIATION RECEPTION	2,807.13	3,850.00	3,850.00	0.00	2,271.83	1,578.17	59.01
101-1780-80200	POSTAGE	0.00	50.00	50.00	0.00	0.00	50.00	0.00
101-1780-82403	EDUCATION	0.00	4,000.00	4,000.00	532.60	1,200.00	2,267.40	43.32
101-1780-85300	TELEPHONE & RADIO	0.00	50.00	50.00	0.00	0.00	50.00	0.00
101-1780-96138	VACCINATION FAIR	2,522.00	3,000.00	3,000.00	420.00	2,350.00	230.00	92.33
101-1780-96139	DOG PARK	0.00	2,100.00	2,100.00	0.00	0.00	2,100.00	0.00
101-1780-96145	CHIPPING CLINIC	2,782.00	3,000.00	3,000.00	0.00	0.00	3,000.00	0.00
101-1780-96149	SPAY/NEUTER CLINIC	0.00	4,000.00	4,000.00	0.00	3,800.00	200.00	95.00
101-1780-96150	COMMUNITY OUTREACH	0.00	2,000.00	2,000.00	0.00	0.00	2,000.00	0.00
101-1793-80100	CONTRACTUAL SERVICES	5,660.00	6,500.00	10,500.00	3,000.00	0.00	7,500.00	28.57
101-1793-80200	POSTAGE	56.79	1,700.00	1,700.00	156.98	0.00	1,543.02	9.23
101-1793-85300	TELEPHONE & RADIO	63.09	200.00	200.00	37.55	0.00	162.45	18.78
101-1793-86100	MILEAGE	395.90	800.00	800.00	394.90	0.00	405.10	49.36
101-1793-92000	PUBLIC UTILITIES	496.69	1,000.00	1,000.00	329.62	0.00	670.38	32.96
101-1793-96102	SCHOOL PROGRAM	1,096.04	1,200.00	1,200.00	0.00	0.00	1,200.00	0.00
101-1793-96103	AWARDS	3,849.51	9,000.00	5,000.00	4,236.14	301.20	462.66	90.75
101-1793-96104	CLEAN-UP CAMPAIGN	0.00	1,500.00	1,500.00	1,204.00	190.42	105.58	92.96
101-1793-96105	INSTALLATION DINNER	606.78	1,000.00	1,000.00	531.50	0.00	468.50	53.15
101-1793-96123	CITY FLOWER PLANTINGS	1,735.00	4,000.00	4,000.00	0.00	0.00	4,000.00	0.00
101-1793-96134	CHRISTMAS DECORATIONS	14,991.00	26,000.00	26,000.00	26,000.00	0.00	0.00	100.00
101-1794-80140	CONT SVCS - SOUND SYSTEM	11,500.00	11,500.00	11,500.00	6,650.00	0.00	4,850.00	57.83
101-1794-96110	SUMMER PROGRAM	16,478.00	16,500.00	16,500.00	13,332.00	0.00	3,168.00	80.80
101-1794-96115	WINTER PROGRAM	771.00	1,000.00	1,000.00	0.00	500.00	500.00	50.00
101-1795-85300	TELEPHONE & RADIO	63.09	300.00	300.00	37.55	0.00	262.45	12.52
101-1795-88001	COMMUNITY PROMOTION/OUTREACH F	514.35	1,200.00	1,200.00	0.00	0.00	1,200.00	0.00
101-1795-95800	MEMBERSHIPS & DUES	263.00	363.00	363.00	218.00	0.00	145.00	60.06
101-1795-96135	HISTORICAL SITE PLAQUES	0.00	1,800.00	1,800.00	0.00	0.00	1,800.00	0.00
101-1795-96140	MUSEUM EXPENSE	2,490.26	11,180.00	11,180.00	2,450.00	0.00	8,730.00	21.91
101-1795-96148	HALL OF FAME	0.00	2,000.00	2,000.00	0.00	0.00	2,000.00	0.00
101-1796-80100	CONTRACTUAL SERVICES	7,857.69	24,000.00	24,000.00	4,524.68	4,312.50	15,162.82	36.82
101-1796-88001	COMMUNITY PROMOTION/OUTREACH F	0.00	5,000.00	5,000.00	0.00	0.00	5,000.00	0.00
101-1796-92000	PUBLIC UTILITIES	7,903.09	3,300.00	3,300.00	1,874.72	0.00	1,425.28	56.81
101-1796-96135	HISTORICAL SITE PLAQUES	0.00	3,200.00	3,200.00	0.00	0.00	3,200.00	0.00
101-1796-96141	OLD VILLAGE HALL IMPROVEM	0.00	15,000.00	15,000.00	0.00	0.00	15,000.00	0.00
101-1797-88001	COMMUNITY PROMOTION/OUTREACH F	0.00	3,000.00	3,000.00	0.00	0.00	3,000.00	0.00
202-2463-80100	CONTRACTUAL SERVICES	151,789.80	464,500.00	464,500.00	13,602.92	50,935.00	399,962.08	13.89
202-2463-80205	JOINT SEALING	72,448.10	300,000.00	300,000.00	0.00	0.00	300,000.00	0.00
202-2463-80206	CONCRETE/PAVEMENT REPAIRS	293,372.40	600,000.00	1,135,806.00	260,266.25	0.00	875,539.75	22.91
202-2463-80207	BRIDGE REPAIRS	1,019,681.80	0.00	0.00	0.00	0.00	0.00	0.00
202-2463-94500	EQUIPMENT RENTAL	154,211.54	305,000.00	305,000.00	170,758.30	0.00	134,241.70	55.99
202-2463-96901	SUPERVISORY WAGES/FRINGES	38,463.45	114,259.00	114,259.00	0.00	0.00	114,259.00	0.00
202-2474-80120	TRAFFIC SIGNALS	119,038.79	240,000.00	246,047.00	7,873.50	0.00	238,173.50	3.20
202-2474-80121	TRAFFIC SIGNAL UPKEEP	350,882.42	300,000.00	300,000.00	197,622.44	0.00	102,377.56	65.87
202-2474-80123	PAVEMENT MARKING	65,546.18	225,000.00	225,000.00	239,398.47	0.00	(14,398.47)	106.40
202-2474-94500	EQUIPMENT RENTAL	6,650.70	28,000.00	28,000.00	5,021.41	0.00	22,978.59	17.93

REVENUE AND EXPENDITURE REPORT

PERIOD ENDING 04/30/2024

% Fiscal Year Completed: 83.33

GL NUMBER	DESCRIPTION	END BALANCE	2023-24		YTD BALANCE	ENCUMBERED	UNENCUMBERED	% BDGT
		06/30/2023	ORIGINAL	2023-24	04/30/2024			
		NORM (ABNORM)	BUDGET	AMENDED BUDGET	NORM (ABNORM)	YEAR-TO-DATE	BALANCE	USED
202-2474-96901	SUPERVISORY WAGES/FRINGES	2,673.83	6,363.00	6,363.00	0.00	0.00	6,363.00	0.00
202-2479-80100	CONTRACTUAL SERVICES	0.00	25,000.00	25,000.00	0.00	0.00	25,000.00	0.00
202-2479-94500	EQUIPMENT RENTAL	91,169.30	120,000.00	120,000.00	64,177.57	0.00	55,822.43	53.48
202-2479-94501	SALT DOME RENTAL	2,500.00	2,500.00	2,500.00	2,500.00	0.00	0.00	100.00
202-2479-96901	SUPERVISORY WAGES/FRINGES	3,977.68	10,883.00	10,883.00	0.00	0.00	10,883.00	0.00
202-2483-95000	ADMINISTRATIVE COSTS	714,800.00	736,200.00	736,200.00	613,500.00	0.00	122,700.00	83.33
202-2483-96592	TRANSFER TO WATER & SEWER	36,822.00	44,209.00	44,209.00	36,840.00	0.00	7,369.00	83.33
202-2483-96901	SUPERVISORY WAGES/FRINGES	(74,388.07)	(131,505.00)	(131,505.00)	0.00	0.00	(131,505.00)	0.00
202-2484-96603	LOCAL STREETS	2,500,000.00	1,000,000.00	1,000,000.00	1,000,000.00	0.00	0.00	100.00
202-2484-96656	TRANS TO MTF 2023 DEBT #356	0.00	1,608,420.00	1,671,013.00	401,637.49	0.00	1,269,375.51	24.04
202-2484-96657	TRANS TO MTF 2022 DEBT #357	922,054.17	923,750.00	923,750.00	279,625.00	0.00	644,125.00	30.27
202-2484-96658	TRANS TO 2021A CAP IMP DEBT #3	322,124.75	311,161.00	311,161.00	311,018.79	0.00	142.21	99.95
202-2484-96659	TRANS TO 2015 CAP IMP DEBT #35	191,643.88	182,750.00	182,750.00	182,748.68	0.00	1.32	100.00
202-2484-96660	TRANS TO MTF 2018 DEBT #360	1,105,017.50	1,101,318.00	1,101,318.00	145,908.75	0.00	955,409.25	13.25
202-2484-96661	TRANS TO MTF 2021 DEBT #361	1,258,700.00	1,256,700.00	1,256,700.00	293,600.00	0.00	963,100.00	23.36
203-3463-80100	CONTRACTUAL SERVICES	75,917.90	710,000.00	710,000.00	51,121.03	110,915.00	547,963.97	22.82
203-3463-80205	JOINT SEALING	24,149.37	100,000.00	100,000.00	0.00	0.00	100,000.00	0.00
203-3463-80206	CONCRETE/PAVEMENT REPAIRS	2,551,303.48	400,000.00	2,251,746.00	1,675,126.35	0.00	576,619.65	74.39
203-3463-94500	EQUIPMENT RENTAL	819,168.06	850,000.00	850,000.00	791,158.34	0.00	58,841.66	93.08
203-3463-96901	SUPERVISORY WAGES/FRINGES	93,244.06	230,887.00	230,887.00	0.00	0.00	230,887.00	0.00
203-3474-80121	TRAFFIC SIGNAL UPKEEP	71,867.49	65,000.00	65,000.00	76,787.42	0.00	(11,787.42)	118.13
203-3474-80123	PAVEMENT MARKING	21,848.72	75,000.00	75,000.00	83,587.50	0.00	(8,587.50)	111.45
203-3474-94500	EQUIPMENT RENTAL	8,298.10	28,000.00	28,000.00	7,989.74	0.00	20,010.26	28.53
203-3474-96901	SUPERVISORY WAGES/FRINGES	8,058.73	18,591.00	18,591.00	0.00	0.00	18,591.00	0.00
203-3479-80100	CONTRACTUAL SERVICES	0.00	20,000.00	20,000.00	0.00	0.00	20,000.00	0.00
203-3479-94500	EQUIPMENT RENTAL	54,734.77	155,000.00	155,000.00	48,896.11	0.00	106,103.89	31.55
203-3479-94501	SALT DOME RENTAL	2,500.00	2,500.00	2,500.00	2,500.00	0.00	0.00	100.00
203-3479-96901	SUPERVISORY WAGES/FRINGES	2,358.39	7,958.00	7,958.00	0.00	0.00	7,958.00	0.00
203-3483-95000	ADMINISTRATIVE COSTS	261,541.37	315,400.00	315,400.00	262,840.00	0.00	52,560.00	83.34
203-3483-96592	TRANSFER TO WATER & SEWER	36,822.00	44,208.00	44,208.00	36,840.00	0.00	7,368.00	83.33
203-3483-96901	SUPERVISORY WAGES/FRINGES	(74,388.07)	(257,436.00)	(257,436.00)	0.00	0.00	(257,436.00)	0.00
204-9204-95000	ADMINISTRATIVE COSTS	288,600.00	297,200.00	297,200.00	247,670.00	0.00	49,530.00	83.33
208-9208-80100	CONTRACTUAL SERVICES	746,501.02	900,000.00	900,000.00	522,676.13	294,281.91	83,041.96	90.77
208-9208-80116	HORTICULTURE CONSULTANT	537.50	55,000.00	55,000.00	187.50	937.50	53,875.00	2.05
208-9208-80200	POSTAGE	291.19	10,000.00	10,000.00	7,936.95	0.00	2,063.05	79.37
208-9208-80301	UNEMPLOYMENT COSTS	4,656.60	0.00	0.00	0.00	0.00	0.00	0.00
208-9208-81400	TREE MAINTENANCE	18,190.00	25,000.00	25,000.00	0.00	15,000.00	10,000.00	60.00
208-9208-85300	TELEPHONE & RADIO	26,930.05	37,350.00	37,350.00	20,185.71	370.61	16,793.68	55.04
208-9208-86300	VEHICLE MAINTENANCE	39,037.24	40,000.00	40,000.00	25,377.29	0.00	14,622.71	63.44
208-9208-88011	MARKETING/PROMOTIONS - PROGRAM	22,340.74	40,000.00	40,000.00	18,332.43	3,389.57	18,278.00	54.31
208-9208-91000	INSURANCE & BONDS	162,300.00	168,700.00	168,700.00	140,590.00	0.00	28,110.00	83.34
208-9208-92000	PUBLIC UTILITIES	480,064.03	500,000.00	500,000.00	397,237.92	0.00	102,762.08	79.45
208-9208-93000	BUILDING MAINTENANCE	91,166.46	115,000.00	115,000.00	31,128.79	4,731.21	79,140.00	31.18
208-9208-94400	RENTAL & JANITORIAL SERV	1,569.07	5,000.00	5,000.00	1,036.00	464.00	3,500.00	30.00
208-9208-95000	ADMINISTRATIVE COSTS	139,600.00	143,700.00	143,700.00	119,750.00	0.00	23,950.00	83.33
208-9208-96126	SPECIAL EVENTS EXPENSES	74,533.60	70,000.00	70,000.00	27,924.72	27,209.80	14,865.48	78.76
208-9208-96127	SPONSORED EVENTS EXPENSE	24,641.80	40,000.00	40,000.00	19,706.00	11,644.00	8,650.00	78.38
208-9208-96146	DOWNTOWN ICE RINK EXPENSE	10,796.41	15,000.00	15,000.00	10,462.33	3,509.79	1,027.88	93.15
208-9208-96470	TRANS TO FUND 386 BOND PMT	245,713.01	250,339.00	250,339.00	250,336.82	0.00	2.18	100.00
208-9210-80100	CONTRACTUAL SERVICES	5,049.50	10,000.00	10,000.00	2,499.65	6,796.00	704.35	92.96
208-9210-80200	POSTAGE	0.00	100.00	100.00	0.00	0.00	100.00	0.00
208-9210-85300	TELEPHONE & RADIO	593.36	1,000.00	1,000.00	510.37	0.00	489.63	51.04
208-9210-86300	VEHICLE MAINTENANCE	20,622.01	20,000.00	20,000.00	18,213.74	469.38	1,316.88	93.42
208-9210-91000	INSURANCE & BONDS	19,600.00	20,300.00	20,300.00	16,920.00	0.00	3,380.00	83.35
208-9210-92000	PUBLIC UTILITIES	14,680.98	18,000.00	18,000.00	7,353.30	0.00	10,646.70	40.85
208-9210-93000	BUILDING MAINTENANCE	11,970.22	15,000.00	15,000.00	2,532.50	1,790.00	10,677.50	28.82
208-9210-94401	BUS RENTAL	0.00	3,000.00	3,000.00	0.00	0.00	3,000.00	0.00
226-9226-80100	CONTRACTUAL SERVICES	15,934.04	15,000.00	40,000.00	6,243.65	1,090.49	32,665.86	18.34

REVENUE AND EXPENDITURE REPORT

PERIOD ENDING 04/30/2024

% Fiscal Year Completed: 83.33

GL NUMBER	DESCRIPTION	END BALANCE	2023-24		YTD BALANCE	ENCUMBERED	UNENCUMBERED	% BDGT
		06/30/2023	ORIGINAL	2023-24	04/30/2024			
		NORM (ABNORM)	BUDGET	AMENDED BUDGET	NORM (ABNORM)	YEAR-TO-DATE	BALANCE	USED
226-9226-80109	HAZARDOUS WASTE COLLECTIO	18,660.10	47,000.00	47,000.00	34,007.19	0.00	12,992.81	72.36
226-9226-80112	CONT SERV - RUBBISH HAUL	1,846,371.41	2,500,000.00	2,500,000.00	1,389,752.31	0.00	1,110,247.69	55.59
226-9226-80113	SMDA - CLOSURE COSTS	9,400.00	20,000.00	20,000.00	16,450.00	0.00	3,550.00	82.25
226-9226-80115	CONT SVC - RECYCLE/COMPST	501,138.22	800,000.00	800,000.00	459,616.21	0.00	340,383.79	57.45
226-9226-80200	POSTAGE	0.00	2,500.00	2,500.00	127.48	0.00	2,372.52	5.10
226-9226-80213	SMDA LEGAL/ENG COSTS	37,600.00	50,000.00	65,800.00	65,800.00	0.00	0.00	100.00
226-9226-80301	UNEMPLOYMENT COSTS	2,191.34	500.00	500.00	500.00	0.00	0.00	100.00
226-9226-85300	TELEPHONE & RADIO	6,753.93	11,875.00	11,875.00	5,906.88	126.74	5,841.38	50.81
226-9226-86300	VEHICLE MAINTENANCE	820,058.50	897,000.00	897,000.00	691,350.00	0.00	205,650.00	77.07
226-9226-90000	PRINTING & PUBLISHING	0.00	2,000.00	2,000.00	0.00	1,000.00	1,000.00	50.00
226-9226-92000	PUBLIC UTILITIES	23,328.82	40,000.00	40,000.00	22,796.07	0.00	17,203.93	56.99
226-9226-93000	BUILDING MAINTENANCE	8,634.42	25,000.00	25,000.00	17,798.72	5,351.38	1,849.90	92.60
226-9226-99400	LEASE PRINCIPAL	1,060,745.00	1,095,886.00	1,095,886.00	1,095,885.85	0.00	0.15	100.00
226-9226-99401	LEASE INTEREST	147,703.39	112,563.00	112,563.00	112,562.54	0.00	0.46	100.00
230-9230-80100	CONTRACTUAL SERVICES	0.00	5,000.00	5,000.00	0.00	0.00	5,000.00	0.00
230-9230-80200	POSTAGE	12,401.78	13,200.00	13,200.00	10,317.39	0.00	2,882.61	78.16
230-9230-85300	TELEPHONE & RADIO	339.29	1,000.00	1,000.00	284.50	0.00	715.50	28.45
230-9230-86300	VEHICLE MAINTENANCE	6,807.22	15,000.00	15,000.00	2,922.71	250.00	11,827.29	21.15
230-9230-95000	ADMINISTRATIVE COSTS	90,400.00	93,100.00	93,100.00	77,590.00	0.00	15,510.00	83.34
250-9250-80100	CONTRACTUAL SERVICES	42,543.34	90,000.00	90,000.00	33,370.07	8,786.36	47,843.57	46.84
250-9250-80147	SOFTWARE & CONTR SERVICE	46,974.24	55,000.00	55,000.00	45,139.93	0.00	9,860.07	82.07
250-9250-80200	POSTAGE	12,767.50	15,000.00	15,000.00	13,307.97	0.00	1,692.03	88.72
250-9250-80301	UNEMPLOYMENT COSTS	0.00	5,000.00	5,000.00	0.00	0.00	5,000.00	0.00
250-9250-85300	TELEPHONE & RADIO	4,296.08	7,000.00	7,000.00	2,449.34	53.99	4,496.67	35.76
250-9250-86300	VEHICLE MAINTENANCE	2,802.50	4,000.00	4,000.00	2,119.02	0.00	1,880.98	52.98
250-9250-86400	CONFERENCES & WORKSHOPS	145.00	3,500.00	3,500.00	0.00	0.00	3,500.00	0.00
250-9250-88001	COMMUNITY PROMOTION/OUTREACH F	14,037.73	15,000.00	15,000.00	9,495.01	3,242.03	2,262.96	84.91
250-9250-88006	SETS & DESIGN	0.00	3,000.00	3,000.00	0.00	2,755.91	244.09	91.86
250-9250-88007	WEB SITE	9,402.43	25,000.00	25,000.00	13,488.00	7,500.00	4,012.00	83.95
250-9250-88008	CITY CALENDAR	45,757.80	50,000.00	50,000.00	31,559.19	0.00	18,440.81	63.12
250-9250-88009	MUSIC LIBRARY	2,000.00	2,000.00	2,000.00	2,000.00	0.00	0.00	100.00
250-9250-88010	AUDITORIUM EXPENSE	16,754.18	25,000.00	27,520.00	14,317.89	3,411.79	9,790.32	64.42
250-9250-91000	INSURANCE & BONDS	46,900.00	48,700.00	48,700.00	40,590.00	0.00	8,110.00	83.35
250-9250-92000	PUBLIC UTILITIES	104,090.45	115,000.00	115,000.00	82,517.70	0.00	32,482.30	71.75
250-9250-95000	ADMINISTRATIVE COSTS	371,300.00	382,400.00	382,400.00	318,670.00	0.00	63,730.00	83.33
250-9250-95800	MEMBERSHIPS & DUES	700.00	13,700.00	13,700.00	13,235.00	0.00	465.00	96.61
250-9250-96470	TRANS TO FUND 386 BOND PMT	351,018.62	357,626.00	357,626.00	357,624.06	0.00	1.94	100.00
259-9259-80100	CONTRACTUAL SERVICES	0.00	0.00	19,136.98	1,301.25	0.00	17,835.73	6.80
259-9259-80301	UNEMPLOYMENT COSTS	0.00	0.00	600.41	0.00	0.00	600.41	0.00
259-9259-82601	COUNSEL FOR INDIGENTS	732,234.96	0.00	3,821,796.07	805,896.55	0.00	3,015,899.52	21.09
260-9260-82211	VICE CRIME EXPENDITURES	21,960.26	60,000.00	60,000.00	24,630.90	608.00	34,761.10	42.06
261-9261-82214	FED JUSTICE FORFEITURE EXP	475,317.00	240,000.00	242,705.00	159,978.00	1,050.00	81,677.00	66.35
261-9261-82215	LOCAL DRUG FORFEITURE EXP	620,789.89	300,000.00	1,445,489.00	1,022,808.37	79,543.45	343,137.18	76.26
262-9262-86400	CONFERENCES & WORKSHOPS	19,235.31	25,000.00	75,000.00	25,976.80	39,337.34	9,685.86	87.09
271-9271-80100	CONTRACTUAL SERVICES	204,845.98	310,700.00	345,700.00	172,654.77	35,202.30	137,842.93	60.13
271-9271-80117	COOPERATIVE SERVICES	166,112.77	219,000.00	219,000.00	171,168.39	0.00	47,831.61	78.16
271-9271-80130	LIBRARY COOP INDIRECT AID	70,674.22	69,000.00	75,000.00	0.00	0.00	75,000.00	0.00
271-9271-80200	POSTAGE	215.29	3,000.00	3,000.00	92.56	200.00	2,707.44	9.75
271-9271-80301	UNEMPLOYMENT COSTS	0.00	800.00	800.00	724.00	0.00	76.00	90.50
271-9271-82201	DIGITAL VIDEO DISCS	16,099.92	16,100.00	16,100.00	11,825.19	0.00	4,274.81	73.45
271-9271-82202	LIBRARY CIRCULATING MAT	100,999.51	101,000.00	101,000.00	63,166.49	0.00	37,833.51	62.54
271-9271-82207	PERIODICALS	19,291.33	22,000.00	26,000.00	1,187.90	24,761.53	50.57	99.81
271-9271-85300	TELEPHONE & RADIO	16,735.28	30,000.00	30,000.00	5,847.59	42.09	24,110.32	19.63
271-9271-86100	MILEAGE	33.48	200.00	200.00	0.00	0.00	200.00	0.00
271-9271-86300	VEHICLE MAINTENANCE	992.61	3,000.00	3,000.00	650.28	0.00	2,349.72	21.68
271-9271-86400	CONFERENCES & WORKSHOPS	7,218.26	15,000.00	15,000.00	5,931.50	489.00	8,579.50	42.80
271-9271-90200	BOOK BINDING	0.00	100.00	100.00	0.00	0.00	100.00	0.00
271-9271-91000	INSURANCE & BONDS	46,900.00	48,700.00	48,700.00	40,590.00	0.00	8,110.00	83.35

REVENUE AND EXPENDITURE REPORT

PERIOD ENDING 04/30/2024

% Fiscal Year Completed: 83.33

GL NUMBER	DESCRIPTION	END BALANCE	2023-24		YTD BALANCE	ENCUMBERED	UNENCUMBERED	% BDGT
		06/30/2023	ORIGINAL	2023-24	04/30/2024			
		NORM (ABNORM)	BUDGET	AMENDED BUDGET	NORM (ABNORM)	YEAR-TO-DATE	BALANCE	USED
271-9271-92000	PUBLIC UTILITIES	215,900.94	220,000.00	220,000.00	163,963.30	0.00	56,036.70	74.53
271-9271-93000	BUILDING MAINTENANCE	18,720.24	61,500.00	134,291.00	50,747.02	73,886.93	9,657.05	92.81
271-9271-95000	ADMINISTRATIVE COSTS	269,100.00	277,100.00	277,100.00	230,920.00	0.00	46,180.00	83.33
271-9271-96470	TRANS TO FUND 386 BOND PMT	105,305.58	107,289.00	107,289.00	107,287.21	0.00	1.79	100.00
273-9441-80183	STREET PROGRAM	0.00	331,996.00	0.00	0.00	0.00	0.00	0.00
273-9441-80183-CD1911	STREET PROGRAM	2,320.00	0.00	0.00	0.00	0.00	0.00	0.00
273-9441-80183-CD2013	STREET PROGRAM	103,543.18	0.00	0.00	0.00	0.00	0.00	0.00
273-9441-80183-CD2111	STREET PROGRAM	27,113.82	0.00	0.00	0.00	0.00	0.00	0.00
273-9441-80183-CD2210	STREET PROGRAM	211,881.26	0.00	0.00	0.00	0.00	0.00	0.00
273-9441-80183-CD2311	STREET PROGRAM	0.00	0.00	331,996.00	0.00	1,700.00	330,296.00	0.51
273-9441-88102-CD2013	PROGRAM INCOME EXPENSE	0.00	106,238.53	0.00	0.00	0.00	0.00	0.00
273-9666-80105-CD1713	INDEPENDENT AUDIT	0.00	3,690.00	0.00	0.00	0.00	0.00	0.00
273-9666-80105-CD1812	INDEPENDENT AUDIT	0.00	3,920.00	0.00	0.00	0.00	0.00	0.00
273-9666-80105-CD2115	INDEPENDENT AUDIT	8,250.00	4,730.00	0.00	0.00	0.00	0.00	0.00
273-9666-80105-CD2213	INDEPENDENT AUDIT	5,650.00	14,350.00	0.00	0.00	0.00	0.00	0.00
273-9666-80111	FAIR HOUSING ACTIVITY	0.00	500.00	0.00	0.00	0.00	0.00	0.00
273-9666-80111-CD2214	FAIR HOUSING ACTIVITY	500.00	0.00	0.00	0.00	0.00	0.00	0.00
273-9666-80111-CD2314	FAIR HOUSING ACTIVITY	0.00	0.00	500.00	0.00	0.00	500.00	0.00
273-9666-86100-CD1713	MILEAGE	0.00	750.00	0.00	0.00	0.00	0.00	0.00
273-9666-86100-CD1812	MILEAGE	0.00	250.00	0.00	0.00	0.00	0.00	0.00
273-9666-86100-CD1912	MILEAGE	0.00	100.00	0.00	0.00	0.00	0.00	0.00
273-9666-86100-CD2015	MILEAGE	0.00	200.00	0.00	0.00	0.00	0.00	0.00
273-9666-86100-CD2115	MILEAGE	0.00	200.00	0.00	0.00	0.00	0.00	0.00
273-9666-86100-CD2213	MILEAGE	0.00	118.00	0.00	0.00	0.00	0.00	0.00
273-9666-86400-CD1912	CONFERENCES & WORKSHOPS	0.00	824.00	0.00	0.00	0.00	0.00	0.00
273-9666-86400-CD2115	CONFERENCES & WORKSHOPS	629.00	571.00	0.00	0.00	0.00	0.00	0.00
273-9666-86400-CD2213	CONFERENCES & WORKSHOPS	0.00	1,000.00	0.00	0.00	0.00	0.00	0.00
273-9666-88102-CD1713	PROGRAM INCOME EXPENSE	0.00	30,000.00	0.00	0.00	0.00	0.00	0.00
273-9666-88102-CD1812	PROGRAM INCOME EXPENSE	0.00	29,954.87	0.00	0.00	0.00	0.00	0.00
273-9666-88102-CD1912	PROGRAM INCOME EXPENSE	0.00	16,657.91	0.00	0.00	0.00	0.00	0.00
273-9666-88102-CD2015	PROGRAM INCOME EXPENSE	0.00	62,645.34	0.00	0.00	0.00	0.00	0.00
273-9666-88102-CD2213	PROGRAM INCOME EXPENSE	5,216.51	24,783.49	5,473.25	0.00	0.00	5,473.25	0.00
273-9666-88102-CD2313	PROGRAM INCOME EXPENSE	0.00	0.00	30,000.00	0.00	0.00	30,000.00	0.00
273-9666-90000	PRINTING & PUBLISHING	0.00	0.00	0.00	1,102.00	0.00	(1,102.00)	100.00
273-9666-90000-CD2213	PRINTING & PUBLISHING	2,490.85	0.00	0.00	0.00	0.00	0.00	0.00
273-9666-91000-CD1713	INSURANCE & BONDS	0.00	500.00	0.00	0.00	0.00	0.00	0.00
273-9666-91000-CD1812	INSURANCE & BONDS	0.00	388.88	0.00	0.00	0.00	0.00	0.00
273-9666-91000-CD1912	INSURANCE & BONDS	0.00	500.00	0.00	0.00	0.00	0.00	0.00
273-9666-91000-CD2015	INSURANCE & BONDS	0.00	500.00	0.00	0.00	0.00	0.00	0.00
273-9666-91000-CD2115	INSURANCE & BONDS	0.00	500.00	0.00	0.00	0.00	0.00	0.00
273-9666-91000-CD2213	INSURANCE & BONDS	0.00	500.00	0.00	0.00	0.00	0.00	0.00
273-9666-95000	ADMINISTRATIVE COSTS	0.00	208,624.00	0.00	2,571.23	100.00	(2,671.23)	100.00
273-9666-95000-CD2015	ADMINISTRATIVE COSTS	0.00	0.00	350.00	0.00	0.00	350.00	0.00
273-9666-95000-CD2115	ADMINISTRATIVE COSTS	0.00	0.00	135,057.29	135,793.29	543.50	(1,279.50)	100.95
273-9666-95000-CD2213	ADMINISTRATIVE COSTS	0.00	0.00	110,376.65	161,442.43	2,822.55	(53,888.33)	148.82
273-9666-95000-CD2313	ADMINISTRATIVE COSTS	0.00	0.00	208,624.00	400.00	0.00	208,224.00	0.19
273-9666-95000-CV2020	ADMINISTRATIVE COSTS	89,114.07	0.00	53,566.19	5,033.89	7.42	48,524.88	9.41
273-9706-80100-CD1702	CONTRACTUAL SERVICES	0.00	2,500.00	0.00	0.00	0.00	0.00	0.00
273-9706-80100-CD1802	CONTRACTUAL SERVICES	0.00	2,500.00	0.00	0.00	0.00	0.00	0.00
273-9706-80100-CD1902	CONTRACTUAL SERVICES	0.00	2,500.00	0.00	0.00	0.00	0.00	0.00
273-9706-80100-CD2003	CONTRACTUAL SERVICES	0.00	2,500.00	0.00	0.00	0.00	0.00	0.00
273-9706-80100-CD2103	CONTRACTUAL SERVICES	0.00	3,500.00	0.00	0.00	0.00	0.00	0.00
273-9706-80100-CD2202	CONTRACTUAL SERVICES	0.00	3,500.00	0.00	0.00	0.00	0.00	0.00
273-9706-80134	DELIVERY COSTS	0.00	110,000.00	0.00	11,112.24	0.00	(11,112.24)	100.00
273-9706-80134-CD1702	DELIVERY COSTS	0.00	12,240.68	0.00	0.00	0.00	0.00	0.00
273-9706-80134-CD1802	DELIVERY COSTS	0.00	10,086.25	0.00	0.00	0.00	0.00	0.00
273-9706-80134-CD1902	DELIVERY COSTS	0.00	12,136.46	0.00	0.00	0.00	0.00	0.00
273-9706-80134-CD2003	DELIVERY COSTS	210.00	9,522.33	7,495.81	(350.85)	0.00	7,846.66	(4.68)

REVENUE AND EXPENDITURE REPORT

PERIOD ENDING 04/30/2024

% Fiscal Year Completed: 83.33

GL NUMBER	DESCRIPTION	END BALANCE	2023-24		YTD BALANCE	ENCUMBERED	UNENCUMBERED	% BDGT
		06/30/2023	ORIGINAL	2023-24	04/30/2024			
		NORM (ABNORM)	BUDGET	AMENDED BUDGET	NORM (ABNORM)	YEAR-TO-DATE	BALANCE	USED
273-9706-80134-CD2103	DELIVERY COSTS	5,795.00	4,716.35	131,543.94	103,699.47	8,100.00	19,744.47	84.99
273-9706-80134-CD2202	DELIVERY COSTS	769.02	4,230.98	0.00	0.00	0.00	0.00	0.00
273-9706-80134-CD2302	DELIVERY COSTS	0.00	0.00	110,000.00	0.00	0.00	110,000.00	0.00
273-9706-80179-CD1702	RISK ASSESSMENT/PAINT INS	0.00	13,345.25	0.00	0.00	0.00	0.00	0.00
273-9706-80179-CD1802	RISK ASSESSMENT/PAINT INS	0.00	3,568.25	0.00	0.00	0.00	0.00	0.00
273-9706-80179-CD1902	RISK ASSESSMENT/PAINT INS	0.00	12,866.00	0.00	0.00	0.00	0.00	0.00
273-9706-80179-CD2003	RISK ASSESSMENT/PAINT INS	0.00	11,336.00	0.00	0.00	0.00	0.00	0.00
273-9706-80179-CD2103	RISK ASSESSMENT/PAINT INS	15,261.25	3,538.75	0.00	0.00	0.00	0.00	0.00
273-9706-80179-CD2202	RISK ASSESSMENT/PAINT INS	0.00	12,000.00	0.00	0.00	0.00	0.00	0.00
273-9706-86100-CD1702	MILEAGE	0.00	500.00	0.00	0.00	0.00	0.00	0.00
273-9706-86100-CD1802	MILEAGE	0.00	100.00	0.00	0.00	0.00	0.00	0.00
273-9706-86100-CD1902	MILEAGE	0.00	100.00	0.00	0.00	0.00	0.00	0.00
273-9706-86100-CD2003	MILEAGE	0.00	59.33	0.00	0.00	0.00	0.00	0.00
273-9706-86100-CD2103	MILEAGE	84.29	15.71	0.00	0.00	0.00	0.00	0.00
273-9706-86100-CD2202	MILEAGE	0.00	100.00	0.00	0.00	0.00	0.00	0.00
273-9706-86400-CD1702	CONFERENCES & WORKSHOPS	0.00	775.00	0.00	0.00	0.00	0.00	0.00
273-9706-86400-CD1802	CONFERENCES & WORKSHOPS	0.00	395.00	0.00	0.00	0.00	0.00	0.00
273-9706-86400-CD2003	CONFERENCES & WORKSHOPS	619.00	131.00	0.00	0.00	0.00	0.00	0.00
273-9706-86400-CD2103	CONFERENCES & WORKSHOPS	190.00	710.00	0.00	0.00	0.00	0.00	0.00
273-9706-86400-CD2202	CONFERENCES & WORKSHOPS	0.00	700.00	0.00	0.00	0.00	0.00	0.00
273-9707-80118	REHAB PROJECT COSTS	0.00	139,500.00	0.00	0.00	0.00	0.00	0.00
273-9707-80118-CD1601	REHAB PROJECT COSTS	0.00	101,047.60	0.00	0.00	0.00	0.00	0.00
273-9707-80118-CD1801	REHAB PROJECT COSTS	0.00	42.57	0.00	0.00	0.00	0.00	0.00
273-9707-80118-CD2001	REHAB PROJECT COSTS	15,435.00	24,879.00	0.00	0.00	0.00	0.00	0.00
273-9707-80118-CD2101	REHAB PROJECT COSTS	14,923.93	9,942.07	0.00	0.00	0.00	0.00	0.00
273-9707-80118-CD2201	REHAB PROJECT COSTS	37,010.00	67,990.00	67,990.00	67,990.00	0.00	0.00	100.00
273-9707-80118-CD2301	REHAB PROJECT COSTS	0.00	0.00	139,500.00	139,500.00	0.00	0.00	100.00
273-9707-88102	PROGRAM INCOME EXPENSE	0.00	0.00	0.00	25,945.05	0.00	(25,945.05)	100.00
273-9707-88102-CD2101	PROGRAM INCOME EXPENSE	10,707.30	0.00	0.00	0.00	0.00	0.00	0.00
273-9707-88102-CD2201	PROGRAM INCOME EXPENSE	281,518.03	132,317.95	196,448.55	68,187.35	0.00	128,261.20	34.71
273-9707-88102-CD2301	PROGRAM INCOME EXPENSE	0.00	0.00	120,000.00	20,880.80	0.00	99,119.20	17.40
273-9707-88203-CD2002	LOCAL MATCH EXPENSE	9,678.80	18,706.20	18,706.20	10,824.50	0.00	7,881.70	57.87
273-9707-88203-CD2102	LOCAL MATCH EXPENSE	0.00	30,000.00	30,000.00	0.00	0.00	30,000.00	0.00
273-9757-80100-CD2112	CONTRACTUAL SERVICES	0.00	200,000.00	200,000.00	0.00	0.00	200,000.00	0.00
273-9757-80100-CD2211	CONTRACTUAL SERVICES	1,300.00	343,342.34	343,342.34	175.00	343,167.34	0.00	100.00
273-9850-80117-CD2012	COOPERATIVE SERVICES	0.00	50.00	0.00	0.00	0.00	0.00	0.00
273-9850-80155	SHELTER FOR HOMELESS MITTEN MI	0.00	15,000.00	0.00	0.00	0.00	0.00	0.00
273-9850-80155-CD2309	SHELTER FOR HOMELESS MITTEN MI	0.00	0.00	15,000.00	15,000.00	0.00	0.00	100.00
273-9850-80156	CHORE SERVICES	0.00	40,000.00	0.00	0.00	0.00	0.00	0.00
273-9850-80156-CD2005	CHORE SERVICES	11,000.00	0.00	0.00	0.00	0.00	0.00	0.00
273-9850-80156-CD2105	CHORE SERVICES	40,000.00	0.00	0.00	0.00	0.00	0.00	0.00
273-9850-80156-CD2204	CHORE SERVICES	0.00	40,000.00	40,000.00	15,584.00	0.00	24,416.00	38.96
273-9850-80156-CD2304	CHORE SERVICES	0.00	0.00	40,000.00	1,456.00	0.00	38,544.00	3.64
273-9850-80157	SHELTER FOR THE HOMELESS	0.00	15,000.00	0.00	0.00	0.00	0.00	0.00
273-9850-80157-CD1909	SHELTER FOR THE HOMELESS	0.00	2,320.00	0.00	0.00	0.00	0.00	0.00
273-9850-80157-CD2007	SHELTER FOR THE HOMELESS	0.00	7,175.00	0.00	0.00	0.00	0.00	0.00
273-9850-80157-CD2010	SHELTER FOR THE HOMELESS	2,380.00	7,370.00	0.00	0.00	0.00	0.00	0.00
273-9850-80157-CD2110	SHELTER FOR THE HOMELESS	2,020.00	4,260.00	0.00	0.00	0.00	0.00	0.00
273-9850-80157-CD2206	SHELTER FOR THE HOMELESS	11,800.00	3,200.00	3,200.00	3,200.00	0.00	0.00	100.00
273-9850-80157-CD2207	SHELTER FOR THE HOMELESS	15,000.00	0.00	0.00	0.00	0.00	0.00	0.00
273-9850-80157-CD2209	SHELTER FOR THE HOMELESS	7,620.00	2,380.00	0.00	0.00	0.00	0.00	0.00
273-9850-80157-CD2307	SHELTER FOR THE HOMELESS	0.00	0.00	15,000.00	0.00	0.00	15,000.00	0.00
273-9850-80158	SHELTER FOR HOMELESS TURNING F	0.00	15,000.00	0.00	0.00	0.00	0.00	0.00
273-9850-80158-CD2306	SHELTER FOR HOMELESS TURNING F	0.00	0.00	15,000.00	15,000.00	0.00	0.00	100.00
273-9850-80159-CD1615	CONTINGENCIES	0.00	4,014.34	0.00	0.00	0.00	0.00	0.00
273-9850-80192	CODE ENFORCEMENT OFFICER	0.00	90,000.00	0.00	0.00	0.00	0.00	0.00
273-9850-80192-CD1603	CODE ENFORCEMENT OFFICER	80,000.00	0.00	0.00	0.00	0.00	0.00	0.00
273-9850-80192-CD2303	CODE ENFORCEMENT OFFICER	0.00	0.00	90,000.00	70,907.38	0.00	19,092.62	78.79

REVENUE AND EXPENDITURE REPORT

PERIOD ENDING 04/30/2024

% Fiscal Year Completed: 83.33

GL NUMBER	DESCRIPTION	END BALANCE	2023-24		YTD BALANCE	ENCUMBERED	UNENCUMBERED	% BDGT
		06/30/2023	ORIGINAL	2023-24	04/30/2024			
		NORM (ABNORM)	BUDGET	AMENDED BUDGET	NORM (ABNORM)	YEAR-TO-DATE	BALANCE	USED
273-9850-80198	HOMELESS PREVENTION	0.00	30,000.00	0.00	0.00	0.00	0.00	0.00
273-9850-80198-CD1605	HOMELESS PREVENTION	0.00	2,352.09	0.00	0.00	0.00	0.00	0.00
273-9850-80198-CD2006	HOMELESS PREVENTION	0.00	20,371.72	0.00	0.00	0.00	0.00	0.00
273-9850-80198-CD2106	HOMELESS PREVENTION	2,274.90	0.00	0.00	0.00	0.00	0.00	0.00
273-9850-80198-CD2205	HOMELESS PREVENTION	24,060.00	940.00	0.00	0.00	0.00	0.00	0.00
273-9850-80198-CD2305	HOMELESS PREVENTION	0.00	0.00	30,000.00	13,316.22	0.00	16,683.78	44.39
273-9850-80198-CV2019	HOMELESS PREVENTION	436,748.12	0.00	0.00	0.00	0.00	0.00	0.00
273-9850-80199	HOMELESS PREVENTION - HEARTS F	0.00	10,000.00	0.00	0.00	0.00	0.00	0.00
273-9850-80199-CD2310	HOMELESS PREVENTION - HEARTS F	0.00	0.00	10,000.00	4,060.00	0.00	5,940.00	40.60
273-9850-80232	CHILD ADVOCACY	0.00	40,000.00	0.00	0.00	0.00	0.00	0.00
273-9850-80232-CD1608	CHILD ADVOCACY	21,047.60	0.00	0.00	0.00	0.00	0.00	0.00
273-9850-80232-CD2208	CHILD ADVOCACY	16,152.40	2,800.00	2,800.00	2,800.00	0.00	0.00	100.00
273-9850-80232-CD2308	CHILD ADVOCACY	0.00	0.00	40,000.00	40,000.00	0.00	0.00	100.00
276-9476-80197-HA2102	ENTITLEMENT	0.00	0.00	1,000,000.00	0.00	0.00	1,000,000.00	0.00
276-9777-95000-HA2103	ADMINISTRATIVE COSTS	0.00	0.00	307,237.00	0.00	0.00	307,237.00	0.00
276-9850-80198-HA2101	HOMELESS PREVENTION	0.00	0.00	741,010.00	0.00	0.00	741,010.00	0.00
277-9474-80149	CHDO RESERVE	0.00	81,565.00	0.00	0.00	0.00	0.00	0.00
277-9474-80149-HM2101	CHDO RESERVE	0.00	84,771.00	84,771.00	0.00	0.00	84,771.00	0.00
277-9474-80149-HM2201	CHDO RESERVE	0.00	100,000.00	100,000.00	0.00	0.00	100,000.00	0.00
277-9474-80149-HM2301	CHDO RESERVE	0.00	0.00	81,565.00	0.00	0.00	81,565.00	0.00
277-9474-88102-HM1901	PROGRAM INCOME EXPENSE	0.00	24,831.00	24,831.00	0.00	0.00	24,831.00	0.00
277-9476-80197	ENTITLEMENT	0.00	257,823.00	0.00	0.00	0.00	0.00	0.00
277-9476-80197-HM1803	ENTITLEMENT	0.00	13,037.00	13,037.00	0.00	0.00	13,037.00	0.00
277-9476-80197-HM1902	ENTITLEMENT	0.00	342,346.00	342,346.00	0.00	0.00	342,346.00	0.00
277-9476-80197-HM2003	ENTITLEMENT	0.00	377,875.00	377,875.00	0.00	0.00	377,875.00	0.00
277-9476-80197-HM2103	ENTITLEMENT	0.00	413,851.00	413,851.00	0.00	0.00	413,851.00	0.00
277-9476-80197-HM2203	ENTITLEMENT	0.00	367,375.00	367,375.00	0.00	0.00	367,375.00	0.00
277-9476-80197-HM2303	ENTITLEMENT	0.00	0.00	257,823.00	0.00	0.00	257,823.00	0.00
277-9476-88102	PROGRAM INCOME EXPENSE	0.00	137,697.00	0.00	0.00	0.00	0.00	0.00
277-9476-88102-HM2103	PROGRAM INCOME EXPENSE	187,441.90	80,538.00	80,538.00	40,125.50	0.00	40,412.50	49.82
277-9476-88102-HM2303	PROGRAM INCOME EXPENSE	0.00	0.00	137,697.00	0.00	0.00	137,697.00	0.00
277-9476-88203	LOCAL MATCH EXPENSE	38,436.29	0.00	0.00	7,402.75	0.00	(7,402.75)	100.00
277-9476-88204-HM2203	IN KIND MATCH EXPENSE	0.00	25,000.00	25,000.00	0.00	0.00	25,000.00	0.00
277-9674-88102	PROGRAM INCOME EXPENSE	0.00	0.00	0.00	19,788.73	0.00	(19,788.73)	100.00
277-9707-80118	REHAB PROJECT COSTS	0.00	150,000.00	0.00	0.00	0.00	0.00	0.00
277-9707-80118-HM1602	REHAB PROJECT COSTS	0.00	147,758.40	147,758.40	87,289.75	0.00	60,468.65	59.08
277-9707-80118-HM1702	REHAB PROJECT COSTS	0.00	34,416.00	34,416.00	0.00	0.00	34,416.00	0.00
277-9707-80118-HM1802	REHAB PROJECT COSTS	0.00	23,639.00	23,639.00	0.00	0.00	23,639.00	0.00
277-9707-80118-HM2002	REHAB PROJECT COSTS	0.00	5,000.00	5,000.00	0.00	0.00	5,000.00	0.00
277-9707-80118-HM2102	REHAB PROJECT COSTS	0.00	10,000.00	10,000.00	0.00	0.00	10,000.00	0.00
277-9707-80118-HM2302	REHAB PROJECT COSTS	0.00	0.00	150,000.00	0.00	0.00	150,000.00	0.00
277-9707-88102	PROGRAM INCOME EXPENSE	0.00	75,000.00	0.00	0.00	0.00	0.00	0.00
277-9707-88102-HM2002	PROGRAM INCOME EXPENSE	62,811.41	5,050.09	5,050.09	0.00	0.00	5,050.09	0.00
277-9707-88102-HM2102	PROGRAM INCOME EXPENSE	214,232.11	126,605.25	126,605.25	(1,428.27)	0.00	128,033.52	(1.13)
277-9707-88102-HM2202	PROGRAM INCOME EXPENSE	29,785.00	0.00	0.00	75,000.00	0.00	(75,000.00)	100.00
277-9707-88102-HM2302	PROGRAM INCOME EXPENSE	0.00	0.00	75,000.00	0.00	0.00	75,000.00	0.00
277-9777-80105-HM2105	INDEPENDENT AUDIT	0.00	5,000.00	5,000.00	0.00	0.00	5,000.00	0.00
277-9777-80105-HM2204	INDEPENDENT AUDIT	0.00	5,000.00	5,000.00	0.00	0.00	5,000.00	0.00
277-9777-86400-HM2105	CONFERENCES & WORKSHOPS	0.00	500.00	500.00	0.00	0.00	500.00	0.00
277-9777-86400-HM2204	CONFERENCES & WORKSHOPS	0.00	500.00	500.00	0.00	0.00	500.00	0.00
277-9777-88102	PROGRAM INCOME EXPENSE	0.00	23,633.00	0.00	0.00	0.00	0.00	0.00
277-9777-88102-HM2105	PROGRAM INCOME EXPENSE	25,199.46	0.00	0.00	168.75	1,034.75	(1,203.50)	100.00
277-9777-88102-HM2204	PROGRAM INCOME EXPENSE	0.00	46,142.00	46,142.00	0.00	0.00	46,142.00	0.00
277-9777-88102-HM2304	PROGRAM INCOME EXPENSE	0.00	0.00	23,633.00	0.00	0.00	23,633.00	0.00
277-9777-90000-HM2105	PRINTING & PUBLISHING	197.00	236.00	236.00	0.00	0.00	236.00	0.00
277-9777-90000-HM2204	PRINTING & PUBLISHING	510.00	0.00	0.00	0.00	0.00	0.00	0.00
277-9777-95000	ADMINISTRATIVE COSTS	0.00	54,376.00	0.00	494.00	0.00	(494.00)	100.00
277-9777-95000-HM2304	ADMINISTRATIVE COSTS	0.00	0.00	54,376.00	0.00	0.00	54,376.00	0.00

REVENUE AND EXPENDITURE REPORT

PERIOD ENDING 04/30/2024

% Fiscal Year Completed: 83.33

GL NUMBER	DESCRIPTION	END BALANCE	2023-24		YTD BALANCE	ENCUMBERED	UNENCUMBERED	% BDGT
		06/30/2023	ORIGINAL	2023-24	04/30/2024			
		NORM (ABNORM)	BUDGET	AMENDED BUDGET	NORM (ABNORM)	YEAR-TO-DATE	BALANCE	USED
278-9778-80100	CONTRACTUAL SERVICES HOUSING A	0.00	60,000.00	0.00	0.00	0.00	0.00	0.00
278-9778-80100-WA2303	CONTRACTUAL SERVICES HOUSING A	0.00	0.00	60,000.00	0.00	0.00	60,000.00	0.00
278-9778-80105-WA2105	INDEPENDENT AUDIT	0.00	6,100.00	0.00	0.00	0.00	0.00	0.00
278-9778-80105-WA2205	INDEPENDENT AUDIT	0.00	6,100.00	0.00	0.00	0.00	0.00	0.00
278-9778-80136	MASTER LEASING PROGRAM	0.00	60,000.00	0.00	0.00	0.00	0.00	0.00
278-9778-80136-WA2207	MASTER LEASING PROGRAM	0.00	50,000.00	50,000.00	0.00	0.00	50,000.00	0.00
278-9778-80136-WA2306	MASTER LEASING PROGRAM	0.00	0.00	60,000.00	0.00	0.00	60,000.00	0.00
278-9778-80138	SHORTTERM RENT MTG UTILITY	0.00	80,000.00	0.00	0.00	0.00	0.00	0.00
278-9778-80138-WA2001	SHORTTERM RENT MTG UTILITY	2,164.00	0.00	0.00	0.00	0.00	0.00	0.00
278-9778-80138-WA2101	SHORTTERM RENT MTG UTILITY	11,013.39	635.63	635.63	635.63	0.00	0.00	100.00
278-9778-80138-WA2201	SHORTTERM RENT MTG UTILITY	4,141.13	21,342.28	21,342.28	13,456.42	0.00	7,885.86	63.05
278-9778-80138-WA2301	SHORTTERM RENT MTG UTILITY	0.00	0.00	80,000.00	44,561.68	0.00	35,438.32	55.70
278-9778-80138-WACV01	SHORTTERM RENT MTG UTILITY	19,237.68	0.00	0.00	0.00	0.00	0.00	0.00
278-9778-80139	MOVE IN ASSISTANCE	0.00	60,000.00	0.00	0.00	0.00	0.00	0.00
278-9778-80139-WA2006	MOVE IN ASSISTANCE	18,341.78	0.00	0.00	0.00	0.00	0.00	0.00
278-9778-80139-WA2106	MOVE IN ASSISTANCE	12,449.23	15,870.50	12,906.60	12,906.60	0.00	0.00	100.00
278-9778-80139-WA2206	MOVE IN ASSISTANCE	1,210.49	0.00	0.00	0.00	0.00	0.00	0.00
278-9778-80139-WA2305	MOVE IN ASSISTANCE	0.00	0.00	60,000.00	16,901.44	0.00	43,098.56	28.17
278-9778-80139-WACV06	MOVE IN ASSISTANCE	3,864.00	0.00	0.00	0.00	0.00	0.00	0.00
278-9778-80235-WACV07	PROJECT SPONSOR ADMIN	2,806.64	0.00	0.00	0.00	0.00	0.00	0.00
278-9778-80236	HOUSING ADVOCACY ASSIST.	0.00	400,000.00	0.00	0.00	0.00	0.00	0.00
278-9778-80236-WA2002	HOUSING ADVOCACY ASSIST.	1,253.69	0.00	0.00	0.00	0.00	0.00	0.00
278-9778-80236-WA2102	HOUSING ADVOCACY ASSIST.	60,034.73	44,148.62	0.00	0.00	0.00	0.00	0.00
278-9778-80236-WA2202	HOUSING ADVOCACY ASSIST.	168,942.36	0.00	129,503.58	90,906.32	0.00	38,597.26	70.20
278-9778-80236-WA2302	HOUSING ADVOCACY ASSIST.	0.00	0.00	400,000.00	129,725.01	0.00	270,274.99	32.43
278-9778-80237	TENANT BASED RENTAL ASST.	(814.00)	677,853.00	0.00	0.00	0.00	0.00	0.00
278-9778-80237-WA2003	TENANT BASED RENTAL ASST.	93,072.62	0.00	0.00	0.00	0.00	0.00	0.00
278-9778-80237-WA2103	TENANT BASED RENTAL ASST.	242,950.89	302,631.55	425,370.58	398,097.50	0.00	27,273.08	93.59
278-9778-80237-WA2203	TENANT BASED RENTAL ASST.	0.00	666,792.25	666,792.25	0.00	0.00	666,792.25	0.00
278-9778-80237-WA2303	TENANT BASED RENTAL ASST.	0.00	0.00	677,853.00	0.00	0.00	677,853.00	0.00
278-9778-80238-WA2104	IN HOME NON-MEDICAL CARE	29,804.18	75,626.51	0.00	0.00	0.00	0.00	0.00
278-9778-80238-WA2204	IN HOME NON-MEDICAL CARE	71,922.39	0.00	78,980.71	19,084.71	0.00	59,896.00	24.16
278-9778-90000-WA2005	PRINTING & PUBLISHING	0.00	700.00	0.00	0.00	0.00	0.00	0.00
278-9778-90000-WA2205	PRINTING & PUBLISHING	1,088.00	1,488.81	0.00	0.00	0.00	0.00	0.00
278-9778-95000	ADMINISTRATIVE COSTS	0.00	41,376.00	0.00	0.00	0.00	0.00	0.00
278-9778-95000-WA2105	ADMINISTRATIVE COSTS	0.00	0.00	19,244.74	576.00	1,500.00	17,168.74	10.79
278-9778-95000-WA2205	ADMINISTRATIVE COSTS	0.00	0.00	35,803.81	0.00	0.00	35,803.81	0.00
278-9778-95000-WA2304	ADMINISTRATIVE COSTS	0.00	0.00	41,376.00	0.00	0.00	41,376.00	0.00
278-9778-95000-WACV05	ADMINISTRATIVE COSTS	2,026.81	0.00	0.00	0.00	0.00	0.00	0.00
280-9476-80134	DELIVERY COSTS	39.33	0.00	0.00	0.00	0.00	0.00	0.00
280-9674-80134	DELIVERY COSTS	15,075.13	0.00	0.00	0.00	0.00	0.00	0.00
281-9666-80105-LH1905	INDEPENDENT AUDIT	0.00	5,040.00	5,040.00	0.00	0.00	5,040.00	0.00
281-9706-80141-LH1903	TITLE SEARCH	1,185.00	1,195.00	1,195.00	1,000.00	195.00	0.00	100.00
281-9706-80177-LH1903	MOLD TESTING	0.00	6,000.00	6,000.00	0.00	0.00	6,000.00	0.00
281-9706-80178-LH1903	ASBESTOS SURVEY	0.00	14,000.00	14,000.00	0.00	0.00	14,000.00	0.00
281-9706-80179-LH1903	RISK ASSESSMENT/PAINT INS	16,711.00	20,195.50	20,195.50	16,050.00	7,500.00	(3,354.50)	116.61
281-9706-80201-LH1903	ENGINEERING & INSP SVCS	0.00	9,000.00	9,000.00	0.00	0.00	9,000.00	0.00
281-9706-80233-LH1903	RELOCATION COSTS	0.00	4,500.00	4,500.00	0.00	0.00	4,500.00	0.00
281-9706-86100-LH1903	MILEAGE	0.00	1,000.00	1,000.00	0.00	0.00	1,000.00	0.00
281-9706-88203-LH1902	LOCAL MATCH EXPENSE	7,014.61	15,757.63	15,757.63	0.00	0.00	15,757.63	0.00
281-9707-80118-LH1901	REHAB PROJECT COSTS	87,106.20	300,358.80	300,358.80	103,150.50	0.00	197,208.30	34.34
281-9707-80228-LH1901	HEALTHY HOMES REHAB	49,290.00	220,710.00	220,710.00	38,929.00	0.00	181,781.00	17.64
281-9707-88203-LH1901	LOCAL MATCH EXPENSE	8,406.80	90,478.20	90,478.20	5,224.50	0.00	85,253.70	5.77
281-9850-80100-LH1904	CONTRACTUAL SERVICES	3,850.00	14,973.46	14,973.46	0.00	0.00	14,973.46	0.00
281-9850-82403-LH1904	EDUCATION	903.00	3,597.00	3,597.00	588.95	0.00	3,008.05	16.37
356-9356-99102	BOND PRINCIPAL - MAJOR	0.00	560,000.00	745,000.00	0.00	0.00	745,000.00	0.00
356-9356-99502	BOND INTEREST MAJOR	0.00	1,047,920.00	925,513.00	401,637.49	0.00	523,875.51	43.40
356-9356-99802	AGENT FEES - MAJOR	0.00	500.00	500.00	0.00	0.00	500.00	0.00

REVENUE AND EXPENDITURE REPORT

PERIOD ENDING 04/30/2024

% Fiscal Year Completed: 83.33

GL NUMBER	DESCRIPTION	END BALANCE	2023-24		YTD BALANCE	ENCUMBERED	UNENCUMBERED	% BDGT
		06/30/2023	ORIGINAL	2023-24	04/30/2024			
		NORM (ABNORM)	BUDGET	AMENDED BUDGET	NORM (ABNORM)	YEAR-TO-DATE	BALANCE	USED
357-9357-99102	BOND PRINCIPAL - MAJOR	505,000.00	365,000.00	365,000.00	0.00	0.00	365,000.00	0.00
357-9357-99502	BOND INTEREST MAJOR	416,554.17	558,250.00	558,250.00	279,125.00	0.00	279,125.00	50.00
357-9357-99802	AGENT FEES - MAJOR	500.00	500.00	500.00	500.00	0.00	0.00	100.00
358-9358-99102	BOND PRINCIPAL - MAJOR	305,305.98	298,123.00	298,123.00	298,122.31	0.00	0.69	100.00
358-9358-99502	BOND INTEREST MAJOR	16,459.59	12,538.00	12,538.00	12,537.30	0.00	0.70	99.99
358-9358-99802	AGENT FEES - MAJOR	359.18	500.00	500.00	359.18	0.00	140.82	71.84
359-9359-99102	BOND PRINCIPAL - MAJOR	164,810.02	159,811.00	159,811.00	159,810.02	0.00	0.98	100.00
359-9359-99502	BOND INTEREST MAJOR	26,421.83	22,529.00	22,529.00	22,528.89	0.00	0.11	100.00
359-9359-99802	AGENT FEES - MAJOR	412.03	410.00	410.00	409.77	0.00	0.23	99.94
360-9360-99102	BOND PRINCIPAL - MAJOR	790,000.00	810,000.00	810,000.00	0.00	0.00	810,000.00	0.00
360-9360-99502	BOND INTEREST MAJOR	314,517.50	290,818.00	290,818.00	145,408.75	0.00	145,409.25	50.00
360-9360-99802	AGENT FEES - MAJOR	500.00	500.00	500.00	500.00	0.00	0.00	100.00
361-9361-99102	BOND PRINCIPAL - MAJOR	640,000.00	670,000.00	670,000.00	0.00	0.00	670,000.00	0.00
361-9361-99502	BOND INTEREST MAJOR	618,200.00	586,200.00	586,200.00	293,100.00	0.00	293,100.00	50.00
361-9361-99802	AGENT FEES - MAJOR	500.00	500.00	500.00	500.00	0.00	0.00	100.00
381-9381-99100	BOND PRINCIPAL PAID	35,189.98	0.00	0.00	35,189.98	0.00	(35,189.98)	100.00
381-9381-99500	BOND INTEREST PAID	1,284.43	0.00	0.00	439.87	0.00	(439.87)	100.00
381-9381-99800	AGENT FEES	87.97	0.00	0.00	90.23	0.00	(90.23)	100.00
385-9385-99001	MAINTENANCE FEES	8,162.50	25,000.00	25,000.00	0.00	0.00	25,000.00	0.00
386-9386-99100	BOND PRINCIPAL PAID	558,206.11	0.00	0.00	600,381.68	0.00	(600,381.68)	100.00
386-9386-99500	BOND INTEREST PAID	143,583.01	0.00	0.00	114,618.32	0.00	(114,618.32)	100.00
386-9386-99800	AGENT FEES	248.09	0.00	0.00	248.09	0.00	(248.09)	100.00
391-9391-99100	BOND PRINCIPAL PAID	1,515,000.00	1,435,000.00	1,435,000.00	1,435,000.00	0.00	0.00	100.00
391-9391-99500	BOND INTEREST PAID	32,589.00	22,559.00	22,559.00	22,559.00	0.00	0.00	100.00
391-9391-99800	AGENT FEES	500.00	500.00	500.00	500.00	0.00	0.00	100.00
392-9392-99100	BOND PRINCIPAL PAID	0.00	585,000.00	585,000.00	0.00	0.00	585,000.00	0.00
392-9392-99500	BOND INTEREST PAID	0.00	1,073,959.00	1,073,959.00	558,458.32	0.00	515,500.68	52.00
392-9392-99800	AGENT FEES	0.00	1,000.00	1,000.00	500.00	0.00	500.00	50.00
393-9393-99100	BOND PRINCIPAL PAID	2,920,000.00	2,885,000.00	2,885,000.00	2,885,000.00	0.00	0.00	100.00
393-9393-99500	BOND INTEREST PAID	422,100.00	335,025.00	335,025.00	335,025.00	0.00	0.00	100.00
393-9393-99800	AGENT FEES	500.00	500.00	500.00	500.00	0.00	0.00	100.00
394-9394-99100	BOND PRINCIPAL PAID	1,010,000.00	1,235,000.00	1,235,000.00	1,235,000.00	0.00	0.00	100.00
394-9394-99500	BOND INTEREST PAID	223,550.00	194,925.00	194,925.00	194,925.00	0.00	0.00	100.00
394-9394-99800	AGENT FEES	500.00	500.00	500.00	500.00	0.00	0.00	100.00
435-9435-96202	CONTRIB TO MAJOR STREETS	101.76	0.00	0.00	0.00	0.00	0.00	0.00
436-9436-96301	TRANS TO GENERAL FUND	0.04	0.00	0.00	0.00	0.00	0.00	0.00
437-9437-80129	BOND ISSUANCE COSTS	219,758.40	0.00	0.00	0.00	0.00	0.00	0.00
438-9438-80129	BOND ISSUANCE COSTS	0.00	0.00	0.00	199,251.55	0.00	(199,251.55)	100.00
492-9492-80100	CONTRACTUAL SERVICES	27,774.19	0.00	0.00	29,687.00	0.00	(29,687.00)	100.00
492-9492-80701	PROJECT COSTS - LIPARI WBCE PF	399,024.25	0.00	0.00	0.00	0.00	0.00	0.00
492-9492-80702	PROJECT COSTS - DKM	104,157.47	0.00	0.00	79,644.71	0.00	(79,644.71)	100.00
492-9492-80703	PROJECT COSTS - UNIVERSAL	265,395.27	0.00	0.00	0.00	0.00	0.00	0.00
492-9492-80704	PROJECT COSTS - STAR WARREN	15,482.96	0.00	0.00	0.00	0.00	0.00	0.00
492-9492-80705	PROJECT COSTS - MEIJER	403,615.22	0.00	0.00	0.00	0.00	0.00	0.00
492-9492-80799	MISC CAPTURES DUE	50,443.15	0.00	0.00	0.00	0.00	0.00	0.00
493-9493-80100	CONTRACTUAL SERVICES	30.00	0.00	0.00	0.00	0.00	0.00	0.00
493-9493-80129	BOND ISSUANCE COSTS	222,405.36	0.00	0.00	0.00	0.00	0.00	0.00
493-9493-96494	TRANS TO DDA ADMIN FUND	260,975.36	0.00	0.00	0.00	0.00	0.00	0.00
494-9494-80100	CONTRACTUAL SERVICES	341,323.59	0.00	500,000.00	290,390.52	200,864.26	8,745.22	98.25
494-9494-80200	POSTAGE	103.13	150.00	150.00	60.59	0.00	89.41	40.39
494-9494-85300	TELEPHONE & RADIO	271.44	700.00	700.00	217.20	0.00	482.80	31.03
494-9494-86100	MILEAGE	784.41	1,500.00	1,500.00	1,338.84	0.00	161.16	89.26
494-9494-86400	CONFERENCES & WORKSHOPS	2,753.07	7,800.00	7,800.00	0.00	0.00	7,800.00	0.00
494-9494-92000	PUBLIC UTILITIES	120.00	3,000.00	3,000.00	956.39	0.00	2,043.61	31.88
494-9494-95000	ADMINISTRATIVE COSTS	419,200.00	431,700.00	431,700.00	359,750.00	0.00	71,950.00	83.33
494-9494-95800	MEMBERSHIPS & DUES	7,700.00	12,000.00	12,000.00	700.00	2,785.00	8,515.00	29.04
494-9494-96123	CITY FLOWER PLANTINGS	14,455.00	30,000.00	30,000.00	0.00	16,715.00	13,285.00	55.72
494-9494-96391	TRANS TO 2013 (2002) DDA DEBT	1,548,089.00	1,458,059.00	1,458,059.00	1,458,059.00	0.00	0.00	100.00

REVENUE AND EXPENDITURE REPORT

PERIOD ENDING 04/30/2024

% Fiscal Year Completed: 83.33

GL NUMBER	DESCRIPTION	END BALANCE	2023-24		YTD BALANCE	ENCUMBERED	UNENCUMBERED	% BDGT
		06/30/2023	ORIGINAL	2023-24	04/30/2024			
		NORM (ABNORM)	BUDGET	AMENDED BUDGET	NORM (ABNORM)	YEAR-TO-DATE	BALANCE	USED
494-9494-96392	TRANS TO 2023 DDA GEN OB #392	0.00	1,659,959.00	1,659,959.00	558,583.32	0.00	1,101,375.68	33.65
494-9494-96393	TRANS TO 2014 (2003&2004) DDA	3,342,600.00	3,220,525.00	3,220,525.00	3,220,525.00	0.00	0.00	100.00
494-9494-96394	TRANS TO 2015 (2005 DDA) DEBT	1,234,050.00	1,430,425.00	1,430,425.00	1,430,425.00	0.00	0.00	100.00
495-9495-80100	CONTRACTUAL SERVICES	62,041.15	150,000.00	150,000.00	38,956.67	0.00	111,043.33	25.97
495-9495-80200	POSTAGE	0.00	25.00	25.00	2.51	0.00	22.49	10.04
495-9495-80204	FACADE IMPROVEMNT PROGRAM	0.00	100,000.00	100,000.00	0.00	0.00	100,000.00	0.00
495-9495-85300	TELEPHONE & RADIO	0.00	100.00	100.00	6.24	0.00	93.76	6.24
495-9495-88001	COMMUNITY PROMOTION/OUTREACH F	3,980.34	0.00	0.00	0.00	0.00	0.00	0.00
495-9495-92000	PUBLIC UTILITIES	0.00	250.00	250.00	178.12	0.00	71.88	71.25
495-9495-93000	BUILDING MAINTENANCE	20.51	5,000.00	5,000.00	2,802.05	0.00	2,197.95	56.04
536-9536-80100	CONTRACTUAL SERVICES	85,804.81	132,550.00	132,550.00	83,315.47	86,010.63	(36,776.10)	127.75
536-9536-80200	POSTAGE	0.00	500.00	500.00	365.65	0.00	134.35	73.13
536-9536-85300	TELEPHONE & RADIO	13,425.11	15,200.00	15,200.00	3,932.65	205.43	11,061.92	27.22
536-9536-86300	VEHICLE MAINTENANCE	1,383.72	500.00	500.00	195.38	0.00	304.62	39.08
536-9536-91000	INSURANCE & BONDS	37,300.00	38,700.00	38,700.00	32,250.00	0.00	6,450.00	83.33
536-9536-92000	PUBLIC UTILITIES	183,171.99	175,000.00	175,000.00	136,829.91	0.00	38,170.09	78.19
536-9536-93000	BUILDING MAINTENANCE	25,553.76	76,500.00	76,500.00	11,147.79	5,847.71	59,504.50	22.22
536-9536-95000	ADMINISTRATIVE COSTS	84,000.00	86,500.00	86,500.00	72,080.00	0.00	14,420.00	83.33
536-9536-96807	PYMT TO CITY IN LIEU TAX	28,125.00	29,238.00	29,238.00	0.00	0.00	29,238.00	0.00
536-9536-96810	DEPR EXPENSE - REPLACEMENT COS	139,275.95	0.00	0.00	0.00	0.00	0.00	0.00
537-9537-80100	CONTRACTUAL SERVICES	115,216.56	231,650.00	231,650.00	178,342.34	93,196.97	(39,889.31)	117.22
537-9537-80200	POSTAGE	196.47	1,500.00	1,500.00	384.06	0.00	1,115.94	25.60
537-9537-85300	TELEPHONE & RADIO	7,666.18	8,000.00	8,000.00	7,684.66	19.21	296.13	96.30
537-9537-86300	VEHICLE MAINTENANCE	339.97	1,500.00	1,500.00	0.00	0.00	1,500.00	0.00
537-9537-91000	INSURANCE & BONDS	27,000.00	28,000.00	28,000.00	23,340.00	0.00	4,660.00	83.36
537-9537-92000	PUBLIC UTILITIES	112,787.63	125,000.00	125,000.00	70,333.85	0.00	54,666.15	56.27
537-9537-93000	BUILDING MAINTENANCE	56,304.15	229,500.00	229,500.00	39,813.38	19,012.12	170,674.50	25.63
537-9537-95000	ADMINISTRATIVE COSTS	559,381.00	587,677.00	587,677.00	487,680.00	0.00	99,997.00	82.98
537-9537-96810	DEPR EXPENSE - REPLACEMENT COS	222,902.29	0.00	0.00	0.00	0.00	0.00	0.00
537-9537-99500	BOND INTEREST PAID	1,125.00	0.00	0.00	0.00	0.00	0.00	0.00
537-9537-99800	AGENT FEES	20.83	0.00	0.00	0.00	0.00	0.00	0.00
592-1540-80100	CONTRACTUAL SERVICES	848,071.79	750,000.00	750,000.00	311,195.44	35,487.96	403,316.60	46.22
592-1540-85300	TELEPHONE & RADIO	21,262.52	40,000.00	40,000.00	18,695.10	231.06	21,073.84	47.32
592-1540-86300	VEHICLE MAINTENANCE	430,052.13	450,000.00	450,000.00	337,627.14	4,535.00	107,837.86	76.04
592-1540-92000	PUBLIC UTILITIES	103,017.03	110,000.00	110,000.00	72,058.15	0.00	37,941.85	65.51
592-1540-97500	FACILITY MAINTENANCE	22,170.43	260,040.00	260,040.00	13,525.46	32,396.77	214,117.77	17.66
592-1560-80100	CONTRACTUAL SERVICES	169,122.13	450,000.00	450,000.00	155,240.72	16,006.89	278,752.39	38.06
592-1560-80105	INDEPENDENT AUDIT	18,200.00	18,700.00	18,700.00	18,700.00	0.00	0.00	100.00
592-1560-80200	POSTAGE	264,029.81	275,000.00	275,000.00	265,967.40	200.00	8,832.60	96.79
592-1560-80300	UNEMPLOYMENT BENEFITS	0.00	5,000.00	5,000.00	0.00	0.00	5,000.00	0.00
592-1560-85300	TELEPHONE & RADIO	9,586.00	11,000.00	11,000.00	6,409.16	0.00	4,590.84	58.27
592-1560-86300	VEHICLE MAINTENANCE	2,496.84	1,000.00	1,000.00	2,751.18	0.00	(1,751.18)	275.12
592-1560-91000	INSURANCE & BONDS	600,000.00	600,000.00	600,000.00	500,000.00	0.00	100,000.00	83.33
592-1560-92000	PUBLIC UTILITIES	670.54	800.00	800.00	557.71	0.00	242.29	69.71
592-1560-95000	ADMINISTRATIVE COSTS	2,876,900.00	2,963,200.00	2,963,200.00	2,469,340.00	0.00	493,860.00	83.33
592-1580-80100	CONTRACTUAL SERVICES	217,588.18	230,000.00	230,000.00	160,875.98	12,500.00	56,624.02	75.38
592-1580-81800	ASH REMOVAL	94,822.94	300,000.00	300,000.00	318,853.27	125,000.00	(143,853.27)	147.95
592-1580-85300	TELEPHONE & RADIO	43,572.98	65,000.00	65,000.00	37,186.30	1,099.01	26,714.69	58.90
592-1580-86300	VEHICLE MAINTENANCE	109,325.89	100,000.00	100,000.00	90,197.30	7,172.51	2,630.19	97.37
592-1580-92000	PUBLIC UTILITIES	852,223.70	900,000.00	900,000.00	400,684.87	0.00	499,315.13	44.52
592-1580-96201	MANAGEMENT AGENCY FEES	24,916.50	25,000.00	25,000.00	22,495.00	0.00	2,505.00	89.98
701-9701-80001	PAID WARREN CONSOLIDATED	27,038,616.58	0.00	0.00	29,630,253.35	0.00	(29,630,253.35)	100.00
701-9701-80002	PAID CENTER LINE SCHOOLS	6,847,035.61	0.00	0.00	7,409,785.39	0.00	(7,409,785.39)	100.00
701-9701-80003	PAID WARREN WOODS SCHOOLS	8,359,810.30	0.00	0.00	9,299,909.86	0.00	(9,299,909.86)	100.00
701-9701-80004	PAID VAN DYKE SCHOOLS	9,824,914.09	0.00	0.00	10,139,812.73	0.00	(10,139,812.73)	100.00
701-9701-80005	PAID FITZGERALD SCHOOLS	8,495,384.92	0.00	0.00	9,839,509.57	0.00	(9,839,509.57)	100.00
701-9701-80006	PAID EAST DETROIT SCHOOLS	1,818,459.89	0.00	0.00	1,977,118.99	0.00	(1,977,118.99)	100.00
701-9701-80007	PAID COUNTY TREASURER-TAX	21,693,029.38	0.00	0.00	22,879,697.18	0.00	(22,879,697.18)	100.00

REVENUE AND EXPENDITURE REPORT

PERIOD ENDING 04/30/2024

% Fiscal Year Completed: 83.33

GL NUMBER	DESCRIPTION	END BALANCE	2023-24		YTD BALANCE	ENCUMBERED	UNENCUMBERED	% BDGT
		06/30/2023	ORIGINAL	2023-24	04/30/2024			
		NORM (ABNORM)	BUDGET	AMENDED BUDGET	NORM (ABNORM)	YEAR-TO-DATE	BALANCE	USED
701-9701-80008	PAID STATE OF MICHIGAN	2,205,722.38	0.00	0.00	0.00	0.00	0.00	0.00
701-9701-80009	PAID MACOMB COUNTY COLLEG	5,238,258.26	0.00	0.00	5,513,404.82	0.00	(5,513,404.82)	100.00
701-9701-80010	PAID MACOMB INTERMEDIATE	18,188,571.84	0.00	0.00	19,614,453.86	0.00	(19,614,453.86)	100.00
701-9701-80011	PD COUNTY-MI S.E.T. TAX	23,072,020.47	0.00	0.00	24,509,411.47	0.00	(24,509,411.47)	100.00
701-9701-80013	PD MACOMB CO - LATE FEES	16,559.19	0.00	0.00	0.00	0.00	0.00	0.00
701-9701-96204	TRANSFER TO RDS SPEC REV	7,439,165.84	0.00	0.00	6,863,440.00	0.00	(6,863,440.00)	100.00
701-9701-96208	TRANSFER TO REC SPEC REV	3,438,054.66	0.00	0.00	3,168,720.00	0.00	(3,168,720.00)	100.00
701-9701-96226	TRANSFER TO SAN SPEC REV	10,320,085.36	0.00	0.00	9,509,240.00	0.00	(9,509,240.00)	100.00
701-9701-96247	TRANS TO TIFA OPERATING	383,660.46	0.00	0.00	0.00	0.00	0.00	0.00
701-9701-96271	TRANSFER TO LIB SPEC REV	4,715,476.94	0.00	0.00	4,347,510.00	0.00	(4,347,510.00)	100.00
701-9701-96280	TRANS TO BROWNFIELD AUTH	1,432,968.15	0.00	0.00	0.00	0.00	0.00	0.00
701-9701-96301	TRANS TO GENERAL FUND	74,945,300.26	0.00	0.00	68,946,280.00	0.00	(68,946,280.00)	100.00
701-9701-96302	TRANS TO GENL FUND- WEEDS	41,100.93	0.00	0.00	0.00	0.00	0.00	0.00
701-9701-96303	TRANS GENL FUND ADMIN FEE	1,350,332.38	0.00	0.00	0.00	0.00	0.00	0.00
701-9701-96304	TRANS GENL FUND-PENALTIES	284,706.88	0.00	0.00	0.00	0.00	0.00	0.00
701-9701-96494	TRANS TO DDA ADMIN FUND	7,448,299.95	0.00	0.00	6,094,160.00	0.00	(6,094,160.00)	100.00
701-9701-96500	REFUND OF CURRENT TAXES	378,803.98	0.00	0.00	456,017.41	0.00	(456,017.41)	100.00
701-9701-96592	TRANSFER TO WATER & SEWER	194,309.53	0.00	0.00	0.00	0.00	0.00	0.00
701-9701-96704	TRANS TO S/A FUND 802	77,848.39	0.00	0.00	0.00	0.00	0.00	0.00
801-9801-96700	NUISANCE ABATEMENT EXPENS	89,932.00	0.00	0.00	112,347.05	111,113.61	(223,460.66)	100.00
802-9802-80182	SIDEWALK REPLACEMENT	500,059.23	0.00	0.00	20,116.90	0.00	(20,116.90)	100.00
802-9802-80200	POSTAGE	279.00	0.00	0.00	0.00	0.00	0.00	0.00
802-9802-96381	TRANS 2008 CAP IMP DEBT SA	36,562.38	0.00	0.00	35,720.08	0.00	(35,720.08)	100.00
900-0000-96811	DEPR EXPENSE - GENERAL GOV	2,112,041.78	0.00	0.00	0.00	0.00	0.00	0.00
900-0000-96812	DEPR EXPENSE - PUBLIC SAFETY	3,222,926.95	0.00	0.00	0.00	0.00	0.00	0.00
900-0000-96813	DEPR EXPENSE - CITY DEV	344,175.30	0.00	0.00	0.00	0.00	0.00	0.00
900-0000-96814	DEPR EXPENSE - SANITATION	2,497,925.42	0.00	0.00	0.00	0.00	0.00	0.00
900-0000-96815	DEPR EXPENSE - REC & CULTURE	1,946,898.59	0.00	0.00	0.00	0.00	0.00	0.00
900-0000-96816	DEPR EXPENSE - HIGHWAYS & STRE	5,699,622.88	0.00	0.00	0.00	0.00	0.00	0.00
Net OTHER SERVICES & CHARGES		316,945,287.28	68,863,839.72	81,896,504.19	286,964,216.76	5,020,315.34	(210,088,027.91)	356.53
OPERATING EXPENSE								
592-1537-92700	WATER PURCHASES	11,248,234.46	11,155,000.00	11,155,000.00	7,171,136.72	0.00	3,983,863.28	64.29
592-1537-95100	BAD DEBT EXPENSE	(10,361.03)	100,000.00	100,000.00	0.00	0.00	100,000.00	0.00
592-1540-80250	DIRT REMOVAL	178,198.58	200,000.00	200,000.00	196,826.00	53,174.00	(50,000.00)	125.00
592-1540-80251	CONCRETE & SOD REPLACEMNT	1,646,714.93	1,200,000.00	1,200,000.00	305,409.10	0.00	894,590.90	25.45
592-1540-80253	ASSET MANAGEMENT PLAN EXPENSES	212,114.10	0.00	245,392.00	56,325.48	252,085.00	(63,018.48)	125.68
592-1540-80254	LEAD AND COPPER RULE REPLACEM	262,970.00	750,000.00	750,000.00	225,350.00	167,305.00	357,345.00	52.35
592-1560-96160	M.S.D.W.A. ANNUAL FEE	33,101.93	35,000.00	35,000.00	35,192.56	0.00	(192.56)	100.55
592-1580-80252	ODOR CONTROL	31,969.12	50,000.00	50,000.00	0.00	0.00	50,000.00	0.00
592-1580-92005	ELECTRIC POWER	1,172,712.52	1,240,000.00	1,240,000.00	902,618.37	10,000.00	327,381.63	73.60
592-1580-93001	REPAIRS AND MAINTENANCE	673,148.94	700,000.00	736,270.00	518,598.88	473,165.77	(255,494.65)	134.70
592-1580-93020	HEALTH, SAFETY & SECURITY	280,771.58	250,000.00	250,000.00	197,547.88	169,145.17	(116,693.05)	146.68
Net OPERATING EXPENSE		15,729,575.13	15,680,000.00	15,961,662.00	9,609,004.99	1,124,874.94	5,227,782.07	67.25
CAPITAL OUTLAY								
101-1101-98000	OFFICE EQUIPMENT	4,884.99	0.00	0.00	0.00	0.00	0.00	0.00
101-1136-98200	BOOKS	13,512.77	13,500.00	13,500.00	10,744.44	2,330.56	425.00	96.85
101-1209-98400	EQUIPMENT	28,165.00	0.00	0.00	0.00	0.00	0.00	0.00
101-1210-98001	COMPUTER EQUIPMENT	3,117.13	0.00	0.00	0.00	0.00	0.00	0.00
101-1215-98000	OFFICE EQUIPMENT	0.00	36,945.00	36,945.00	7,762.81	0.00	29,182.19	21.01
101-1220-98001	COMPUTER EQUIPMENT	0.00	15,000.00	15,000.00	459.12	0.00	14,540.88	3.06
101-1253-98000	OFFICE EQUIPMENT	26,029.78	14,000.00	14,000.00	12,749.10	0.00	1,250.90	91.07
101-1258-98001	COMPUTER EQUIPMENT	84,637.05	250,000.00	250,000.00	0.00	0.00	250,000.00	0.00
101-1265-98100	VEHICLES	48,041.00	50,000.00	50,000.00	48,932.61	0.00	1,067.39	97.87
101-1265-98400	EQUIPMENT	0.00	50,000.00	50,000.00	0.00	0.00	50,000.00	0.00
101-1265-98408	EQUIPMENT - MAINTENANCE	35,997.78	0.00	0.00	0.00	0.00	0.00	0.00

REVENUE AND EXPENDITURE REPORT

PERIOD ENDING 04/30/2024

% Fiscal Year Completed: 83.33

GL NUMBER	DESCRIPTION	END BALANCE	2023-24		YTD BALANCE	ENCUMBERED	UNENCUMBERED	% BDGT
		06/30/2023	ORIGINAL	2023-24	04/30/2024			
		NORM (ABNORM)	BUDGET	AMENDED BUDGET	NORM (ABNORM)	YEAR-TO-DATE	BALANCE	USED
101-1294-98500	ARPA EXPENDITURES	37,638.50	0.00	311,079.00	14,579.00	0.00	296,500.00	4.69
101-1301-97400	CAPITAL IMPROVEMENTS	350,801.08	690,000.00	768,033.00	102,357.50	0.00	665,675.50	13.33
101-1301-98000	OFFICE EQUIPMENT	14,166.42	41,050.00	41,050.00	0.00	0.00	41,050.00	0.00
101-1301-98402	POLICE EQUIPMENT	345,796.68	846,723.00	1,094,258.00	636,591.75	77,878.40	379,787.85	65.29
101-1301-98414	911 EQUIPMENT EXPENSE	13,279.35	5,000.00	14,641.00	13,679.22	840.00	121.78	99.17
101-1301-98479	2022 JAG GRANT EXPENSE	68,522.76	0.00	12,924.00	0.00	0.00	12,924.00	0.00
101-1301-98486	2023 JAG GRANT EXPENSE	0.00	0.00	86,318.00	45,050.84	14,204.01	27,063.15	68.65
101-1301-98501	2020 BYRNE JAG EXPENSE	12,607.15	0.00	0.00	0.00	0.00	0.00	0.00
101-1301-98503	2019 BYRNE JAG EXPENSES - SIMU	9,775.00	0.00	0.00	0.00	0.00	0.00	0.00
101-1301-98504	2021 BYRNE JAG EXPENSE	0.00	0.00	12,813.00	0.00	0.00	12,813.00	0.00
101-1336-97400	CAPITAL IMPROVEMENTS	325,705.68	1,914,107.00	6,416,047.00	703,567.57	5,150,538.98	561,940.45	91.24
101-1336-98401	FIRE EQUIPMENT	574,835.37	1,694,000.00	1,889,615.00	1,456,415.62	82,351.97	350,847.41	81.43
101-1336-98469	MI ECONOMIC DEVELOPMENT MEDC	0.00	0.00	400,000.00	0.00	400,000.00	0.00	100.00
101-1371-98000	OFFICE EQUIPMENT	58,992.52	17,000.00	17,000.00	0.00	0.00	17,000.00	0.00
101-1371-98100	VEHICLES	199,873.00	134,000.00	141,400.00	127,853.00	0.00	13,547.00	90.42
101-1400-98000	OFFICE EQUIPMENT	11,524.00	0.00	0.00	0.00	0.00	0.00	0.00
101-1421-98000	OFFICE EQUIPMENT	7,952.00	0.00	0.00	0.00	0.00	0.00	0.00
101-1422-98100	VEHICLES	35,200.00	192,500.00	210,100.00	17,600.00	0.00	192,500.00	8.38
101-1422-98400	EQUIPMENT	1,109.66	26,000.00	26,000.00	25,000.00	0.00	1,000.00	96.15
101-1442-97400	CAPITAL IMPROVEMENTS	126,911.89	600,000.00	1,307,050.00	4,775.30	4,272.81	1,298,001.89	0.69
101-1442-98103	DPW VEHICLES/EQUIPMENT	2,221,736.12	2,235,000.00	3,111,234.00	1,107,329.24	1,448,735.50	555,169.26	82.16
101-1447-98000	OFFICE EQUIPMENT	9,936.80	0.00	0.00	0.00	0.00	0.00	0.00
101-1447-98100	VEHICLES	0.00	46,000.00	145,710.00	96,628.04	0.00	49,081.96	66.32
101-1447-98400	EQUIPMENT	5,058.05	10,000.00	43,000.00	7,442.19	2,025.81	33,532.00	22.02
101-1797-97400	CAPITAL IMPROVEMENTS	0.00	25,000.00	25,000.00	0.00	0.00	25,000.00	0.00
202-2451-97400	CAPITAL IMPROVEMENTS	3,467,145.02	1,600,000.00	4,970,733.00	836,384.75	0.00	4,134,348.25	16.83
203-3451-97400	CAPITAL IMPROVEMENTS	0.00	600,000.00	1,009,057.00	0.00	0.00	1,009,057.00	0.00
204-9204-97400	CAPITAL IMPROVEMENTS	9,275,342.73	7,472,410.00	14,545,361.00	2,773,067.30	0.00	11,772,293.70	19.06
208-9208-97400	CAPITAL IMPROVEMENTS	1,140,570.73	296,500.00	1,188,502.00	137,594.65	60,736.36	990,170.99	16.69
208-9208-98100	VEHICLES	66,856.00	60,000.00	66,024.00	66,024.00	0.00	0.00	100.00
208-9208-98411	EQUIPMENT - RECREATION	49,544.93	70,000.00	70,000.00	38,504.79	0.00	31,495.21	55.01
208-9208-98462	COMMUNITY ENHANCEMENT GRANT	0.00	0.00	1,500,000.00	0.00	0.00	1,500,000.00	0.00
208-9208-98500	ARPA EXPENDITURES	0.00	1,000,000.00	2,200,000.00	0.00	816,602.66	1,383,397.34	37.12
208-9208-98506	PLACEMAKING GT - WEIGAND SPLAS	0.00	0.00	20,000.00	0.00	0.00	20,000.00	0.00
226-9226-97400	CAPITAL IMPROVEMENTS	99,567.17	76,000.00	76,000.00	7,500.00	16,344.00	52,156.00	31.37
226-9226-98100	VEHICLES	311,934.00	924,000.00	1,285,000.00	242,000.00	1,043,000.00	0.00	100.00
226-9226-98400	EQUIPMENT	106,286.67	236,000.00	236,000.00	185,335.82	0.00	50,664.18	78.53
230-9230-98100	VEHICLES	16,300.00	67,000.00	81,600.00	70,390.00	0.00	11,210.00	86.26
250-9250-98100	VEHICLES	0.00	35,000.00	35,000.00	0.00	0.00	35,000.00	0.00
250-9250-98412	CABLE TV EQUIPMENT	77,358.78	30,000.00	102,582.00	55,399.64	24,335.00	22,847.36	77.73
271-9271-97400	CAPITAL IMPROVEMENTS	203,832.48	85,000.00	183,230.00	76,526.71	41,728.00	64,975.29	64.54
271-9271-98000	OFFICE EQUIPMENT	25,783.81	67,000.00	67,000.00	24,089.00	0.00	42,911.00	35.95
271-9271-98100	VEHICLES	27,106.00	0.00	0.00	0.00	0.00	0.00	0.00
271-9271-98200	BOOKS	314,999.80	315,000.00	311,000.00	226,303.93	0.00	84,696.07	72.77
271-9271-98500	ARPA EXPENDITURES	0.00	0.00	2,000,000.00	0.00	0.00	2,000,000.00	0.00
273-9666-98000-CV2020	OFFICE EQUIPMENT	7,084.00	0.00	0.00	0.00	0.00	0.00	0.00
281-9666-98001-LH1905	COMPUTER EQUIPMENT	0.00	374.85	374.85	0.00	0.00	374.85	0.00
410-9410-97400	CAPITAL IMPROVEMENTS	240,334.48	500,000.00	806,932.00	226,025.54	263,011.64	317,894.82	60.60
434-9434-97450	CONSTRUCTION CONTRACTS	5,726,594.95	0.00	0.00	4,073,964.95	0.00	(4,073,964.95)	100.00
437-9437-97450	CONSTRUCTION CONTRACTS	6,793,390.20	0.00	0.00	3,486,987.59	0.00	(3,486,987.59)	100.00
438-9438-97450	CONSTRUCTION CONTRACTS	384,909.78	0.00	0.00	3,823,043.18	0.00	(3,823,043.18)	100.00
493-9493-97450	CONSTRUCTION CONTRACTS	963,219.35	0.00	0.00	1,886,466.97	0.00	(1,886,466.97)	100.00
494-9494-97400	CAPITAL IMPROVEMENTS	1,357,232.96	7,800,000.00	10,855,700.00	2,182,882.68	3,186,468.94	5,486,348.38	49.46
494-9494-98400	EQUIPMENT	2,084,572.14	0.00	0.00	0.00	0.00	0.00	0.00
495-9495-97400	CAPITAL IMPROVEMENTS	0.00	375,000.00	375,000.00	4,814.75	0.00	370,185.25	1.28
495-9495-98400	EQUIPMENT	3,895.22	0.00	0.00	0.00	0.00	0.00	0.00
536-9536-98000	OFFICE EQUIPMENT	0.00	15,000.00	15,000.00	6,256.70	4,668.15	4,075.15	72.83
536-9536-98408	EQUIPMENT - MAINTENANCE	10,021.34	125,000.00	236,500.00	148,587.41	40,644.34	47,268.25	80.01

REVENUE AND EXPENDITURE REPORT

PERIOD ENDING 04/30/2024

% Fiscal Year Completed: 83.33

GL NUMBER	DESCRIPTION	END BALANCE	2023-24		YTD BALANCE	ENCUMBERED	UNENCUMBERED	% BDGT
		06/30/2023	ORIGINAL	2023-24	04/30/2024			
		NORM (ABNORM)	BUDGET	AMENDED BUDGET	NORM (ABNORM)	YEAR-TO-DATE	BALANCE	USED
536-9536-98422	EQUIPMENT-APPLIANCES	10,777.15	18,200.00	18,200.00	3,771.41	5,228.59	9,200.00	49.45
537-9537-98408	EQUIPMENT - MAINTENANCE	8,074.89	500,000.00	761,000.00	388,150.12	102,900.83	269,949.05	64.53
537-9537-98422	EQUIPMENT-APPLIANCES	35,772.45	54,300.00	54,300.00	16,662.63	4,337.37	33,300.00	38.67
592-9044-97001	CONTRACTS AWARDED	342,296.77	11,545,000.00	11,545,000.00	7,457,408.73	0.00	4,087,591.27	64.59
592-9044-97003	BOND ISSUANCE COSTS-WATER	286,549.00	0.00	0.00	0.00	0.00	0.00	0.00
592-9047-98040	EQUIPMENT - WATER MAINT	197,786.60	800,000.00	2,744,881.00	1,149,437.71	595,609.65	999,833.64	63.57
592-9047-98080	EQUIPMENT - WWTP	713,494.01	3,450,000.00	4,684,534.00	3,220,463.53	1,154,627.88	309,442.59	93.39
592-9072-99603	BLDG AUTH BOND INTEREST	3,403.12	0.00	0.00	0.00	0.00	0.00	0.00
592-9072-99604	CAP IMP BOND PRINCIPAL	0.00	6,741,496.00	6,741,496.00	5,416,496.01	0.00	1,324,999.99	80.35
592-9072-99605	CAP IMP BOND INTEREST	3,823,432.21	3,758,553.00	3,758,553.00	2,809,346.89	0.00	949,206.11	74.75
592-9072-99606	SRF BOND PRINCIPAL	0.00	1,345,000.00	1,345,000.00	1,345,000.00	0.00	0.00	100.00
592-9072-99607	SRF BOND INTEREST	113,286.16	92,527.00	92,527.00	92,526.78	0.00	0.22	100.00
592-9072-99611	CAP EQUIP PRINCIPAL	0.00	697,832.00	697,832.00	697,832.47	0.00	(0.47)	100.00
592-9072-99613	INSTALLMENT PUR INTEREST	91,135.12	84,254.00	84,254.00	84,253.53	0.00	0.47	100.00
592-9072-99700	OTHER COSTS	4,184.39	4,000.00	4,000.00	3,892.73	0.00	107.27	97.32
Net CAPITAL OUTLAY		43,059,881.94	59,746,271.85	91,270,889.85	47,702,910.25	14,543,421.45	29,024,558.15	68.20
Unclassified								
101-0080-69436	TRANSFER FROM FUND 436	0.04	0.00	0.00	0.00	0.00	0.00	0.00
202-0080-69435	TRANSFER FROM FUND 435	101.76	0.00	0.00	0.00	0.00	0.00	0.00
280-9779-96273	TRANSFER TO FUND 273	188,499.03	0.00	0.00	0.00	0.00	0.00	0.00
492-0080-40606	TAXES-WARREN 10 MILE LLC	11,610.45	0.00	0.00	0.00	0.00	0.00	0.00
492-0080-40607	TAXES-LECOM/J.A.L.	93,814.46	0.00	0.00	0.00	0.00	0.00	0.00
492-9492-80706	PROJECT COSTS - WARREN 10 LLC	8,486.06	0.00	0.00	0.00	0.00	0.00	0.00
492-9492-80707	PROJECT COSTS LECOM/JAL	84,555.02	0.00	0.00	0.00	0.00	0.00	0.00
494-0080-69493	TRANSFER FROM 493	260,975.36	0.00	0.00	0.00	0.00	0.00	0.00
592-1540-80255	DWSRF GRANT EXPENSES	311.34	0.00	0.00	8,493.38	0.00	(8,493.38)	100.00
Net Unclassified		(84,650.62)	0.00	0.00	8,493.38	0.00	(8,493.38)	100.00
TOTAL REVENUES - ALL FUNDS								
		607,590,389.85	320,544,477.09	364,160,623.39	518,520,850.65	0.00	(154,360,227.26)	142.39
TOTAL EXPENDITURES - ALL FUNDS								
		532,837,422.74	325,975,858.82	369,592,005.12	474,174,499.85	22,308,792.08	(126,891,286.81)	134.33
NET OF REVENUES & EXPENDITURES								
		74,752,967.11	(5,431,381.73)	(5,431,381.73)	44,346,350.80	(22,308,792.08)	(27,468,940.45)	405.74

RESOLUTION RECOGNIZING JUNE AS PRIDE MONTH

WHEREAS, the Warren City Council is committed to fostering an inclusive, diverse and welcoming community for all residents, visitors and employees; and

WHEREAS, Pride Month is a time to celebrate the history, culture and contributions of the LGBTQ+ community, and to acknowledge the ongoing struggles and achievements in the fight for equal rights and acceptance; and

WHEREAS, the Warren City Council acknowledges the importance of promoting equality, dignity and respect for all individuals regardless of sexual orientation, gender identity, or gender expression; and

WHEREAS, the Warren City Council values the diversity of its residents and recognizes that the LGBTQ+ community is an integral part of our social fabric, contributing to the enrichment and vitality of our city; and

WHEREAS, by recognizing Pride Month, the Warren City Council aims to raise awareness, promote inclusivity, and encourage dialogue and understanding among all residents;

NOW, THEREFORE, LET IT BE RESOLVED that we, the Warren City Council does hereby proclaim June as Pride Month in the City of Warren;

BE IT FURTHER RESOLVED, the Warren City Council encourages all residents, businesses and community organizations to join in the observance of Pride Month, to participate in events and activities, and to work towards a future of equality and inclusion for all.

RESOLUTION DECLARED ADOPTED this 28th Day of May, 2024.

*Angela Rogensues, Council President
Melody Magee, Council Vice President
Mindy Moore, Council Secretary
David Dwyer, Council Assistant Secretary
Gary Boike, Councilmember
Jonathan Lafferty, Councilmember
Henry Newnan, Councilmember*

CITY OF WARREN
Office of the Council Secretary

Item 11b

INTER-OFFICE COMMUNICATION

DATE: February 13, 2024

TO: Public Service Director
Lorie Barnwell, City Treasurer

SUBJECT: PUBLIC HEARING: Request to approve the demolition of a house and garage at 11309 Ford through the nuisance abatement program. CONSIDERATION AND ADOPTION OF A RESOLUTION.

At a Regular meeting of the City Council held Tuesday, February 13, 2024, Council made the formal motion to table the above listed item to May 28, 2024 to allow owners time to make progress on the property and make the request that a report on current tax status be provided to Council from the City Treasurer on this and all future nuisance abatements.

Trusting this information to be of value.



Mindy Moore
Council Secretary

cc: Attorney
Clerk
Mayor



December 12, 2023

DEPARTMENT OF PUBLIC SERVICE
ONE CITY SQUARE, SUITE 320
WARREN, MI 48093-5284
(586) 574-4604
FAX (586) 574-4517
www.cityofwarren.org

Mindy Moore, Council Secretary

RE: Resolution for 11309 Ford (house and garage) Nuisance Abatement

Honorable Council Secretary:

The approval of a resolution is necessary for the demolition of a house and garage at 11309 Ford which is under the nuisance abatement program.

Attached, please find the appropriate resolution and place on the January 9, 2024 consent agenda for a February 13, 2024 City Council Meeting.

Thank you for your cooperation in this matter.

Sincerely,

A handwritten signature in blue ink that reads "Gus Ghanam".

Gus Ghanam, Director
Department of Public Service

Read and Concur,

Approved:

A handwritten signature in blue ink that reads "Anna S. 11.2".

City Attorneys Office

Read and Concur,

Approved:

A handwritten signature in blue ink that reads "Lori M. Stone".

Lori M. Stone, Mayor

RDS/al
Cc: Mayor
Building

**Nuisance Abatement
11309 Ford
13-34-209-026**

RESOLUTION APPROVING PUBLIC NUISANCE DETERMINATION

A regular meeting of the council of the City of Warren, County of Macomb, Michigan, held on _____ at 7 p.m. Eastern _____ Time, in the council chamber of the Warren Community Center, 5460 Arden, Warren, Michigan.

PRESENT: Council Members _____

ABSENT: Council Members _____

The following preamble and resolution were offered by Council Member

_____ and supported by Council Member _____:

On **August 24, 2023** a hearing was held before the Hearing Officer for the City of Warren to determine whether a nuisance exists in violation of Section 9-165 thru 9-175 of the Warren Code of Ordinances upon the following described property: **11309 Ford**

Parcel No. **13-34-209-026**

Known as : **LOT 125 – LAETHAM’S NEAR VAN DYKE SUBDIVISION, according to the plat thereof as recorded in liber 8, Page 11 of Plats Macomb County Records.**

The Hearing Officer determined that a public nuisance did in fact exist on the subject Property indicated in violation of the Code of Ordinances, Chapter 9, Article VI, Division 2 to wit:

Warren Code of Ordinances paragraph:

8. **A building or structure, including the adjoining grounds, used or intended to be used for dwelling purposes, because of dilapidation, decay, damage, faulty construction, arrangement, or is otherwise unsanitary or unfit for human habitation, is in a condition that the code official, health officer or designated representative determines is likely to cause sickness or disease, or is likely to injure the health, safety, or general welfare of people living in the dwelling.**

10: **A building or structure that remains unoccupied for a period of one hundred eighty (180) consecutive days or longer, and is not listed as being available for sale, lease, or rent with a real estate broker licensed under Article 25 of the Occupational Code, Act No. 299 of the Public Acts of 1980.**

Determination: Unfit for human habitation and remains unoccupied.

The Hearing Officer has ordered the nuisance be abated by demolition. The City Clerk has notified the subject property's owner(s), occupant(s), or other interested parties, and all property owners or occupants located within three hundred (300) feet of the subject property, of the Hearing Officer's Order of determination of the existence of a public nuisance, and of the date, time and location of the Hearing Officer's Appeal Hearing.

On this date stated above, the council of the City of Warren held an Appeal Hearing of the Hearing Officer's determination that a nuisance exists upon the subject property.

NOW, THEREFORE, IT IS RESOLVED, that after due consideration, it is the opinion of the council of the City of Warren that the determination of the Hearing Officer shall be approved that the **vacant, dilapidated one story house (725 sq. ft.) with crawl space and garage 16 ft. x 20 ft. at: 11309 Ford** has created a dangerous condition as defined by Section 9-165 thru Section 9-175, which constitutes a public nuisance, and shall be abated in accordance with the Order of the Hearing Officer.

IT IS FURTHER RESOLVED, that the nuisance shall be abated within sixty (60) days of this Appeal Hearing date, and if the nuisance is not abated within the time limit, the Director of Public Service is hereby instructed to direct the removal of the nuisance by the proper

department of the City.

IT IS FURTHER RESOLVED, that the demolition bid awarded to the lowest priced qualified contractor, who meets the bid specifications, is hereby approved.

IT IS FURTHER RESOLVED, that the owner(s) of the subject property is hereby notified that a charge for these nuisance proceedings, which includes all administrative costs and costs incurred by the City's personnel or private contractor(s), will be incurred and owed to the City.

IT IS FURTHER RESOLVED, that the Director of Public Service shall keep an accurate record of all expenses incurred in connection with the removal of the nuisance. Upon the completion of any work performed to remove the nuisance, the Director of Public Service shall bill the subject Property's owner(s) for the amount owed, which shall be paid to the City within thirty (30) days.

IT IS FURTHER RESOLVED, that if the expenses incurred by the City in connection with the removal of the nuisance are not paid within the time specified, the City Attorney's Office will be directed to institute collection proceedings, including but not limited to, any civil action that may be available. Accordingly, the Director of Public Service shall charge a special assessment, (SAR) against the subject property for any unpaid nuisance removal expenses.

IT IS FURTHER RESOLVED, that the City Clerk shall record a certified copy of this Resolution Approving Public Nuisance Determination with the Macomb County Register of Deeds.

IT IS FURTHER RESOLVED, that after the removal of the nuisance, the Director of Public Service shall record a Certificate of Removal of Notice of Nuisance Abatement Proceedings with the Macomb County Register of Deeds.

AYES: Council Members

NAYS: Council Members

RESOLUTION DECLARED ADOPTED this _____ day of _____, 2024.

Mindy Moore, Secretary of the Council

CERTIFICATION

STATE OF MICHIGAN)
) SS.
COUNTY OF MACOMB)

I, SONJA BUFFA, duly elected City Clerk for the City of Warren, Macomb County, Michigan, hereby certifies that the foregoing is a true and correct copy of the resolution adopted by the council of the City of Warren at its meeting held on _____, 2024.

SONJA BUFFA
City Clerk

When recorded return to:
One City Square
City Clerk, Suite 205
Warren, Michigan 48093-2393

Reviewed by:
City Attorney's Office
One City Square
Legal Department, Suite 400
Warren, Michigan 48093-5285

NUISANCE ABATEMENT - Dangerous Buildings
Warren Code of Ordinances Chapter 9, Article VI, Division 1 and 2

SPECIFICS FOR CITY COUNCIL

Date 12/8/2023

Property Address 11309 Ford Owners Name Karen Idolski
Sidwell 12-13-34-209-026 Owners Address 21515 Grossedale St.
Subdivision Laethems Near VanDyke lot125 L.8 P.11 Owners City St. Clair Shores Zip 48082
Date of Complaint/Discovery 7/28/2023 Agent _____
Ord. Sec. 9-165, Par, Violation #8 & #10 Agent Address _____

Specifics:

- 1 Posted vacant home since 6/12/2015/ Dilapidated roof covering, failing porch structure.
- 2 Zero water usage since 5/27/2015, overgrown vegetation, failing drainage gutters
- 3 Outstanding blight bills (blight buster clean up performed)
- 4 (3) failure to obtain Vacant Property Registration (VPR) tickets and FTA in court. 9/25/203, \$200 was
- 5 paid to register the property vacant. Owner was duly notified of public hearing at City Hall and failed
- 6 to appear.

Building Size 725 sq. ft. Type Exterior vinyl siding Story 1

Has: foundation, piers, crawl space, basement crawl space

Accessory Building Size(s)

- 1 Garages 16 ft. x 20 ft. detached garage/vinyl sided
- 2 Sheds
- 3 Other

Lot Size 40 ft. x 109 ft.

Utilities Connected gas service pinned off/ zero water since 2015, unsure of DTE service

Date of Nuisance Abatement Hearing 8/24/2023

Owner or representative appearing at hearing FTA

Date/Postings

- 1 Unsafe structure 7/28/2023 Posted Unsafe Structure
- 2 No Occupancy - C/O required 6/12/2015 posted vacant for City Certs.
- 3 Stop work
- 4 Re-postings 2/11/2019 and 9/09/2020 reposted for City Certs.

City Certification inspections obtained none

Permits obtained, Inspections performed

- 1 Building
- 2 Electrical
- 3 Mechanical
- 4 Plumbing

Assessed Value \$34,180 Length of Vacancy 8 years Year Home Built 1955

Taxes paid/pending 2021 forfeited, 2022 summer delinquent, 2023 winter and summer due

Comments & Other Removal: _____



**Additional pictures for
Public Service & Mayor**



**Additional pictures for
Public Service & Mayor**

**Additional pictures for
Public Service & Mayor**



08/01/2023 11:47



Additional pictures for
Public Service & Mayor

08/01/2023 11:47

11209

Additional pictures for
Public Service & Mayor

08/01/2023 11:47

**Additional pictures for
Public Service & Mayor**

08/01/2023 11:48





**Additional pictures for
Public Service & Mayor**

08/01/2023 11:48



Additional pictures for
Public Service & Mayor

08/01/2023 11:49

Additional pictures for
Public Service & Mayor

08/01/2023 11:49





Additional pictures for
Public Service & Mayor

08/01/2023 11:49

11309



Additional pictures for
Public Service & Mayor

08/16/2023 10:55

11209

CITY OF WARREN
NOTICE

CITY OF WARREN
NOTICE

**UNSAFE
STRUCTURE**
THIS BUILDING MAY BE
ORDERED DEMOLISHED BY
THE CITY OF WARREN

8/1/23
7:40

08/01/2023 11:51

Additional pictures for
Public Service & Mayor



Additional pictures for
Public Service & Mayor

08/01/2023 11:50



Additional pictures for
Public Service & Mayor

08/01/2023 11:50



Additional pictures for
Public Service & Mayor

08/01/2023 11:50



Additional pictures for
Public Service & Mayor

08/01/2023 11:50



Additional pictures for
Public Service & Mayor

08/01/2023 11:49



Additional pictures for
Public Service & Mayor

08/01/2023 11:48

CITY OF WARREN
ORDER
ABATEMENT BY DEMOLITION

To: Hearing Attendees
Re: Administrative Hearing - Property Maintenance Ordinance
Division of Buildings and Safety Engineering
Officer: Gus Ghanam

Date: August 24th, 2023
Title: Acting Hearing Officer

Property Description:
Name: Karen Idolski
Address: 11309 Ford Warren, MI 48089 House & Garage
Legal Description: LAETHEM'S NEAR VAN DYKE SUBDIVISION LOT 125
Tax I.D. Number: 12-13-34-209-026
Recorded in Liber: 8 Page: 11 of Macomb County Records
Owner:
Mailing Name: Karen Idolski
Address Address: 22011 Ten Mile
City: St Clair Shores State: MI Zip: 48080
Attorney/Agent: _____

An administrative hearing was held regarding the described property of the above date. The following conditions exist on this property, which make abatement by demolition necessary.

- 1.) 8: A building or structure, including the adjoining grounds, used or intended to be used for dwelling purposes, because of dilapidation, decay, damage, faulty construction, arrangement, or is otherwise unsanitary or unfit for human habitation, is in a condition that the code official, health officer or designated representative determines is likely to cause sickness or disease, or is likely to injure the health, safety, or general welfare of people living in the dwelling.
- 2.) 10: A building or structure that remains unoccupied for a period of one hundred eighty (180) consecutive days or longer, and is not listed as being available for sale, lease, or rent with a real estate broker licensed under Article 25 of the Occupational Code, Act No. 299 of the Public Acts of 1980.

DETERMINATION: unfit for human habitation & remains unoccupied. It has been determined that this property cannot be restored to a condition necessary to meet the Ordinance requirements of the City of Warren in an economical manner. Based on the findings of this hearing, it is ordered that the nuisance as determined be abated by demolition no later than May 27, 2023.

Date

The owner is hereby notified that he/she is responsible to comply with this Order and is responsible for any and all administrative, boarding, demolition, clean up, or other costs incurred by the City to eliminate the dangerous condition of this property due to the owner's failure to comply with this Order.

Pursuant to Ordinance, Section 9-172, you may appeal the determination and order of the Hearing Officer to the City Council by filing a written notice of appeal with the Division of Buildings and Safety Engineering before the date specified for compliance.

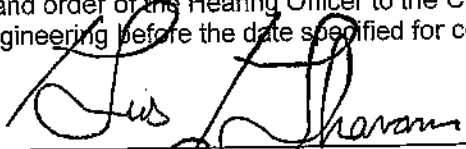
Gus Ghanam, Acting Hearing Officer

In concurrence:

Paul Lize,
Chief Building Inspector

Gus Ghanam,
Department of Public Service

cc: **Attendees**
Director of Public Service
File

CITY OF WARREN

NOTICE OF NUISANCE ABATEMENT PROCEEDINGS

An Administrative Hearing was held on August 24, 2023 at One City Square, Warren, Michigan, between the Hearing Officer for the City of Warren, County of Macomb, State of Michigan, and the last-recorded owner of the property described as:

Owners Name: Karen Idolski

Property address: 11309 Ford Warren MI 48089 **House & Garage**

Property description: LAETHEM'S NEAR VAN DYKE SUBDIVISION LOT 125

Tax I.D. Number: 12-13-34-209-026

Recorded in Liber: 8, Page: 11 of Macomb County Records

WHEREAS, it has been brought to the attention of the City of Warren that the owner of the above-described property has permitted a dangerous condition to exist, to wit:

- 1.) 8: A building or structure, including the adjoining grounds, used or intended to be used for dwelling purposes, because of dilapidation, decay, damage, faulty construction, arrangement, or is otherwise unsanitary or unfit for human habitation, is in a condition that the code official, health officer or designated representative determines is likely to cause sickness or disease, or is likely to injure the health, safety, or general welfare of people living in the dwelling.

- 2.) 10: A building or structure that remains unoccupied for a period of one hundred eighty (180) consecutive days or longer, and is not listed as being available for sale, lease, or rent with a real estate broker licensed under Article 25 of the Occupational Code, Act No. 299 of the Public Acts of 1980.

and such conditions may endanger the health and welfare of the citizens in the immediate area; and specific conditions being: **unfit for human habitation and remains unoccupied.**

WHEREAS, after investigation by the Division of Buildings and Safety Engineering of the City of Warren, after testimony was received and after due consideration, the Hearing Officer for the City of Warren has determined that a dangerous condition exists in violation of Sec. 9-165 or 9-166 of the Code of Ordinances and has ordered abatement pursuant to Chapter 9, Article VI, Division 2, Sec. 9-165 thru 9-175, of the City of Warren Code of Ordinances.

NOW, THEREFORE, BE IT KNOWN that any prospective buyer or assignee be on notice that the City of Warren has declared a nuisance to exist and ordered abatement pursuant to Article VI, Chapter 9 of the Code of Ordinances of the City of Warren.

BE IT FURTHER KNOWN that any prospective buyer or assignee of the above-described property may contact the Division of Buildings and Safety Engineering, located at One City Square, Warren, Michigan, and be informed of any pending action on said property.

BE IT FURTHER KNOWN that the City Clerk shall record a certified copy of this notice with the Macomb County Register of Deeds.

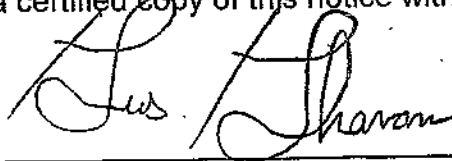

Gus Ghanam, Acting Hearing Officer

CERTIFICATION

STATE OF MICHIGAN)
) SS.
COUNTY OF MACOMB)

I, Sonja Buffa, duly-elected City Clerk for the City of Warren, Macomb County, Michigan, hereby certify that the foregoing is a true and correct copy of the Lis Pendens: Notice of Nuisance Abatement Proceedings.

Sonja Buffa
City Clerk

Drafted and Returned to:
City Clerk
City of Warren
One City Square, #205
Warren, MI 48093-2393

BUILDING DIVISION
NUISANCE ABATEMENT MINUTES
August 24, 2023

In attendance:

Paul Lize, Building Inspector
Laura Sullivan, Assistant City Attorney

The meeting was called to order by Gus Ghanam, Acting Hearing Officer.

21264 Audrey (12-13-32-452-003) House All parties have been duly notified and letters were posted on the building in question. Aaron Bayliss, attorney for MidFirst Bank appeared.

Mr. Ghanam stated that exterior of property needs to be cleaned up, complaints from neighbors regarding tree on property and the safety to surrounding houses. House is dilapidated.

DETERMINATION:

Mr. Ghanam declared public nuisance, send to Public Service for demolition.

Audience Participation

None

21632 Conners (12-13-33-402-003) House & Garage All parties have been duly notified and letters were posted on the building in question. No one appeared.

Mr. Ghanam stated that the owner is deceased, property is dilapidated and the exterior property maintenance needs to be cleaned up.

DETERMINATION:

Mr. Ghanam declared public nuisance, send to Public Service for demolition.

Audience Participation

None

11309 Ford (12-13-34-209-026 House & Garage) All parties have been duly notified and letters were posted on the building in question. No one appeared.

Mr. Ghanam stated that the property has been dilapidated and vacant for over 180 days with no appearance by owner.

DETERMINATION:

Mr. Ghanam declared public nuisance, send to Public Service for demolition.

Audience Participation

None

COLONIAL TITLE COMPANY

27500 Harper Ave.
St. Clair Shores, MI 48081
Phone: (586)774-5950
Fax: (586)774-7040

FAX COVER LETTER

To: Mandy Wells
Company Name: City of Warren - Building Division
Fax No.: (586)574-4577
Email: mwells@cityofwarren.org
Customer No.: 2424774
Date: July 27, 2023
From: Shannon

Property Address: 11309 Ford, Warren, MI 48089

File No.: 24165

Message: Attached is your requested search and invoice. Please call Colonial Title Company with any questions or problems you may have. Thank you for your business.

ADDITIONAL COMMENTS:

Invoice

Remit payment to:
Colonial Title Company
27500 Harper Ave.
St. Clair Shores, MI 48081

Billed to:
City of Warren - Building Division
One City Square, Suite 305
Warren, MI 48093

Invoice number: 24165
Invoice date: July 27, 2023
Please pay before: August 10, 2023
Our file number: 24165
Your reference number: 2424774

Property:
11309 Ford
Warren, MI 48089
Macomb County

DESCRIPTION	AMOUNT
Title Search Fee	85.00
Invoice total amount due:	\$ 85.00

COLONIAL TITLE COMPANY SEARCH REPORT

Record Search Furnished to: Mandy Wells
City of Warren - Building Division
One City Square, Suite 305
Warren, MI 48093

Customer Reference Number: 2424774

This search consists of entries recorded with the Office of the Register of Deeds, based upon legal description herein.

This is not a Title Insurance Policy, and should not be relied upon as such. THIS IS NOT AN "ENVIRONMENTAL SEARCH".

In consideration of the issuance of this search, it is agreed that Colonial Title Company, shall not be liable for any loss of damage arising from incorrectness or incompleteness of this search unless such incorrectness or incompleteness is the result of the intentional omission or misdescription by the Company, with the formed intent of harming the applicant of the search. In no event, as evidenced by the charge for this search, does Colonial Title Company undertake any liability arising from:

1. Consequential or punitive damages, loss of anticipated profits, costs of toxic waste cleanup or other loss so related;
 2. Any type of loss which would result from the accuracy of a determination that any street address given and legal description searched constitute the same premises;
 3. Any instrument (however designated) filed in the Office of the Register of Deeds pursuant to the Uniform Commercial Code P.A. 1962, No. 174, effective January 1, 1964; and/or
 4. Any records of the Circuit, Probate or other Courts nor any records other than the records in the Office of the Register of Deeds.
-

Covering property described as: 11309 Ford, Warren, MI 48089

We have searched the records in the Office of the Register of Deeds for Macomb County and find no conveyances describing said property in said office up to July 14, 2023 at 8:00am.

See attached Rider "B"

Colonial Title Company
Stephen DeBates, President

RIDER "B"
SEARCH OF TITLE

From examination of the records in the Register of Deeds Office, Macomb County, Michigan, up to July 14, 2023 at 8:00am.

PROPERTY DESCRIPTION:

Land Situated in the City of Warren, County of Macomb and State of Michigan described as follows:

Lot 125 - Laetham's Near Van Dyke Subdivision, according to the plat thereof as recorded in Liber 8, Page 11 of Plats, Macomb County Records.

Commonly Known As: 11309 Ford, Warren, MI 48089

Tax ID Number: 12-13-34-209-026

Apparent Owner: Karen Idolski
Title Deed dated 10/03/2012, recorded 01/31/2014, in Liber 22662, Page 224, Macomb County Records.

PAYMENT OF TAXES: Tax Parcel No.: 12-13-34-209-026
Address: 11309 Ford, Warren, MI 48089
2023 Summer Taxes in the amount of \$1,462.32 are DUE
2022 Winter Taxes in the amount of \$18.59 are DUE
2022 Summer Taxes in the amount of \$1,331.21 are DELINQUENT
2021 Taxes in the amount of \$1,801.23 are FORFEITED
Special Assessments Included In The Current Year Tax Bills:
Amount: \$556.25 Period: Summer Desc: WEED
Special Assessments Separate From the Tax Bills: Must confirm with city
- 2023 State Equalized Value: \$26,080.00
- 2023 Taxable Value: \$12,790.00

Certificate of Forfeiture filed by the Macomb County Treasurer for non payment of the 2021 taxes, dated 03/01/2023, recorded 04/04/2023, in Liber 29071, Page 184, Macomb County Records.

Claim of Lien dated 06/01/2023, recorded 06/02/2023, in Liber 29152, Page 379, Macomb County Records.

Under this form of Search, this Company is not an Insurer of the above Title, nor does it guarantee the Title or any evidence thereto and is not liable for any inaccuracies involving environmental searches or determinations.

The liability is limited to the amount paid for the Search. Rider attached to and forming a part of Search No. 24165

Colonial Title Company
Stephen DeBates, President

11309 FORD WARREN, MI 48089 (Property Address)

Parcel Number: 12-13-34-209-026 Account Number: 201986694



Item 1 of 2 1 Image / 1 Sketch

Property Owner: IDOLSKI KAREN

Summary Information

- > Residential Building Summary
 - Year Built: 1955
 - Bedrooms: 0
 - Full Baths: 1
 - Half Baths: 0
 - Sq. Feet: 725
 - Acres: 0.100
- > 20 Building Department records found
- > Assessed Value: \$26,080 | Taxable Value: \$12,790
- > 1 Special Assessment found
- > Property Tax information found
- > Utility Billing information found

Owner and Taxpayer Information

Owner	IDOLSKI KAREN 22011 TEN MILE ST CLAIR SHORES, MI 48080	Taxpayer	SEE OWNER INFORMATION
--------------	--	-----------------	-----------------------

General Information for Tax Year 2023

Property Class	401 RESIDENTIAL-IMPROVED	Unit	12 CITY OF WARREN
School District	VAN DYKE PUBLIC SCHOOLS	Assessed Value	\$26,080
Notes	NEZ - Patriot Place	Taxable Value	\$12,790
PP CLASS / YEAR	0	State Equalized Value	\$26,080
NOTES	Not Available	Date of Last Name Change	02/05/2014
BUSINESS TYPE	Not Available	Notes	Not Available
Historical District	Not Available	Census Block Group	Not Available
NOTES	Not Available	Exemption	No Data to Display

Principal Residence Exemption Information

Homestead Date	05/28/2002		
Principal Residence Exemption		June 1st	Final
2023		0.0000 %	0.0000 %

Previous Year Information

Year	MBOR Assessed	Final SEV	Final Taxable
2022	\$21,280	\$21,280	\$12,181
2021	\$19,470	\$19,470	\$11,792
2020	\$18,310	\$18,310	\$11,630

Land Information

Zoning Code	R-1-C	Total Acres	0.100
Land Value	\$7,320	Land Improvements	\$0
Renaissance Zone	No	Renaissance Zone Expiration	No Data to Display
ECF Neighborhood	VAN DYKE 34	Date	
Lot Dimensions/Comments	Not Available	Mortgage Code	No Data to Display
		Neighborhood Enterprise	No
		Zone	

Lot(s)	Frontage	Depth
Lot 1	40.00 ft	109.00 ft
Total Frontage: 40.00 ft		Average Depth: 109.00 ft

Legal Description

LAETHEM'S NEAR VAN DYKE SUBDIVISION LOT 125 L.8 P.11

Land Division Act Information

Date of Last Split/Combine	No Data to Display	Number of Splits Left	0
Date Form Filed	No Data to Display	Unallocated Div.s of Parent	0
Date Created	01/01/0001	Unallocated Div.s Transferred	0
Acceage of Parent	0.00	Rights Were Transferred	Not Available
Split Number	0	Courtesy Split	Not Available
Parent Parcel	No Data to Display		

Sale History

Sale Date	Sale Price	Instrument	Grantor	Grantee	Terms of Sale	Liber/Page
10/03/2012	\$10,000.00	WD	ANDERSON DANICA	IDOLSKJ KAREN	03-ARM'S LENGTH	22662/224
04/15/2011	\$6,001.00	OTH	HUD	ANDERSON DANICA	33-TO BE DETERMINED	20731/938
10/29/2010	\$1.00	PTA	BUTLER AMANDA	HUD	10-FORECLOSURE	
04/20/2010	\$1.00	QC	WELLS FARGO BANK	HUD	33-TO BE DETERMINED	20499/675
04/16/2010	\$76,726.00	PTA	BUTLER AMANDA	WELLS FARGO BANK	10-FORECLOSURE	
10/16/2009	\$76,725.00	SD	BUTLER AMANDA	WELLS FARGO BANK	10-FORECLOSURE	19998/1
06/27/2002	\$74,900.00	WD	JESSICA RUSSO (Hambleton)	Amanda J Butler	03-ARM'S LENGTH	11992 599
12/09/1998	\$46,500.00	WD			03-ARM'S LENGTH	
09/25/1998	\$0.00	OTH			33-TO BE DETERMINED	
10/02/1990	\$33,500.00	WD			03-ARM'S LENGTH	

Building Information - 725 sq ft 1 Story (Residential)

General

Floor Area	725 sq ft	Estimated TCV	Not Available
Garage Area	320 sq ft	Basement Area	0 sq ft
Foundation Size	725 sq ft	Year Remodeled	No Data to Display
Year Built	1955	Class	CD
Occupancy	Single Family	Tri-Level	No
Effective Age	61 yrs	Heat	Forced Air w/ Ducts
Percent Complete	100%	Wood Stove Add-on	No
AC w/Separate Ducts	No	Water	Not Available
Basement Rooms	0	Sewer	Not Available
1st Floor Rooms	4	Style	1 Story
2nd Floor Rooms	0		
Bedrooms	0		

Area Detail - Basic Building Areas

Height	Foundation	Exterior	Area	Heated
1 Story	Crawl Space	Siding	725 sq ft	1 Story

Basement Finish

Recreation	0 sq ft	Recreation % Good	0%
Living Area	0 sq ft	Living Area % Good	0%
Walk Out Doors	0	No Concrete Floor Area	0 sq ft

Plumbing Information

3 Fixture Bath 1

Garage Information

Area	320 sq ft	Exterior	Siding
Foundation	42 Inch	Common Wall	Detached
Year Built	1998	Finished	No
Auto Doors	0	Mech Doors	0

Porch Information

CPP	85 sq ft	Foundation	Standard
CPP	14 sq ft	Foundation	Standard

11309 FORD WARREN, MI 48089 (Property Address)

Parcel Number: 12-13-34-209-026 Account Number: 201986694



Item 1 of 2 1 Image / 1 Sketch

Property Owner: IDOLSKI KAREN

Summary Information

- > Residential Building Summary
 - Year Built: 1955
 - Full Baths: 1
 - Sq. Feet: 725
 - Bedrooms: 0
 - Half Baths: 0
 - Acres: 0.100
- > 20 Building Department records found

- > Assessed Value: \$26,080 | Taxable Value: \$12,790
- > 1 Special Assessment found
- > Property Tax Information found
- > Utility Billing Information found

Owner and Taxpayer Information

Owner IDOLSKI KAREN Taxpayer SEE OWNER INFORMATION
 22011 TEN MILE
 ST CLAIR SHORES, MI
 48080

Amount Due

Current Taxes: \$1,462.32
[Pay Now](#)

Legal Description

LAETHEM'S NEAR VAN DYKE SUBDIVISION LOT 125 L.B.P.11

Other Information

Recalculate amounts using a different Payment Date

You can change your anticipated payment date in order to recalculate amounts due as of the specified date for this property.

Enter a Payment Date

7/27/2023

[Recalculate](#)

Tax History

****Note:** On March 1 at 12:00 AM, Summer and Winter local taxes become ineligible for payment at the local unit.

Year	Season	Total Amount	Total Paid	Last Paid	Total Due
2023	Summer	\$1,462.32	\$0.00		\$1,462.32 Pay Now
General information for 2023 Summer Taxes					
School District	50220	PRE/MBT	0.0000%		
Taxable Value	\$12,790	S.E.V.	\$26,080		
Property Class	401 - RESIDENTIAL-IMPROVED	Assessed Value	\$26,080		
Tax Bill Number	No Data to Display	Last Receipt Number	No Data to Display		
Last Payment Date	No Data to Display	Number of Payments	0		
Due Date	08/31/2023				
Base Tax	\$1,456.78	Base Paid	\$0.00		
Admin Fees	\$5.54	Admin Fees Paid	\$0.00		
Interest Fees	\$0.00	Interest Fees Paid	\$0.00		
Total Tax & Fees	\$1,462.32	Total Paid	\$0.00		
Renaissance Zone	Not Available	Mortgage Code	Not Available		
Tax Bill Breakdown for 2023 Summer					

Taxing Authority	Millage Rate	Amount	Amount Paid
WARREN OPERATING	8.326300	\$106.49	\$0.00
CITY ROAD IMPROV	2.002900	\$25.61	\$0.00
EMS	0.277000	\$3.54	\$0.00
LIBRARY	1.266700	\$16.22	\$0.00
SANITATION	2.775000	\$35.49	\$0.00
ACT 345 POL/FIRE	4.984800	\$63.75	\$0.00
POLICE OPERATING	0.928900	\$11.88	\$0.00
FIRE OPERATING	0.928900	\$11.88	\$0.00
POL & FIRE OPER	4.674100	\$59.78	\$0.00
RECREATION	0.924700	\$11.82	\$0.00
MACOMB CNTY OPER	4.320000	\$55.25	\$0.00
MCC OPERATING	1.407700	\$18.00	\$0.00
MAC INT SCH DIST	4.630000	\$59.21	\$0.00
STATE ED TAX	6.000000	\$76.74	\$0.00
VAN DYKE OPERAT	18.000000	\$230.22	\$0.00
VAN DYKE DEBT/SF	8.964600	\$114.65	\$0.00
WEED	0.000000	\$556.25	\$0.00
Admin Fees		\$5.54	\$0.00
Interest Fees		\$0.00	\$0.00
	70.413600	\$1,462.32	\$0.00

[Click here for your Summer 2023 Tax Bill](#)

[Click here for a printer friendly version of Summer 2023 Tax Information](#)

2022	Winter	\$18.59	\$0.00	\$18.59	** Read Note(s) Above
------	--------	---------	--------	---------	-----------------------

General Information for 2022 Winter Taxes

School District	50220	PRE/MBT	0.0000%
Taxable Value	\$12,181	Assessed Value	\$21,280
Property Class	401 - RESIDENTIAL-IMPROVED		
Tax Bill Number	No Data to Display	Last Receipt Number	No Data to Display
Last Payment Date	No Data to Display	Number of Payments	0
Base Tax	\$18.41	Base Paid	\$0.00
Admin Fees	\$0.18	Admin Fees Paid	\$0.00
Interest Fees	\$0.00	Interest Fees Paid	\$0.00
Total Tax & Fees	\$18.59	Total Paid	\$0.00

Tax Bill Breakdown for 2022 Winter

Taxing Authority	Millage Rate	Amount	Amount Paid
MACOMB VETERANS	0.065200	\$0.79	\$0.00
HURON-CLINT PARK	0.207000	\$2.52	\$0.00
SMART	0.950000	\$11.57	\$0.00
ZOO AUTHORITY	0.094500	\$1.15	\$0.00
ART INSTITUTE	0.195600	\$2.38	\$0.00
Adm'n Fees		\$0.18	\$0.00
Interest Fees		\$0.00	\$0.00
	1.512300	\$18.59	\$0.00

[Click here for a printer friendly version of Winter 2022 Tax information](#)

2022	Summer	\$1,219.94	\$0.00	\$1,219.94	** Read Note(s) Above
2021	Winter	\$42.24	\$0.00	\$42.24	** Read Note(s) Above
2021	Summer	\$1,155.81	\$0.00	\$1,155.81	** Read Note(s) Above
2020	Winter	\$19.33	\$0.00	\$19.33	** Read Note(s) Above
2020	Summer	\$1,254.81	\$0.00	\$1,254.81	** Read Note(s) Above
2019	Winter	\$21.06	\$0.00	\$21.06	** Read Note(s) Above
2019	Summer	\$1,087.73	\$0.00	\$1,087.73	** Read Note(s) Above
2018	Winter	\$17.78	\$0.00	\$17.78	** Read Note(s) Above
2018	Summer	\$1,059.00	\$0.00	\$1,059.00	** Read Note(s) Above

[Load More Years](#)

**Disclaimer: BS&A Software provides BS&A Online as a way for municipalities to display information online and is not responsible for the content or accuracy of the data herein. This data is provided for reference only and WITHOUT WARRANTY of any kind, expressed or inferred. Please contact your local municipality if you believe there are errors in the data.

Copyright © 2023 BS&A Software, Inc.

11309 FORD WARREN, MI 48089 (Property Address)
 Parcel Number: 12-13-34-209-026 Account Number: 201986694



Item 1 of 2 1 Image / 1 Sketch

Property Owner: IDOLSKI KAREN

Summary Information

- > Residential Building Summary
 - Year Built: 1955 - Bedrooms: 0
 - Full Baths: 1 - Half Baths: 0
 - Sq. Feet: 725 - Acres: 0.100
- > 20 Building Department records found

- > Assessed Value: \$26,080 | Taxable Value: \$12,790
- > 1 Special Assessment found
- > Property Tax Information found
- > Utility Billing Information found

Owner and Taxpayer Information

Amount Due
 Special Assessment Total Payoff Amount: **\$0.00**

Owner IDOLSKI KAREN **Taxpayer** SEE OWNER INFORMATION
 22011 TEN MILE
 ST CLAIR SHORES,
 MI 48080

Legal Description

Legal Description not on file.

Special Assessment Information

Code	Name	Special Assessment District Status	APR Interest Rate	Start Year	Number of Years	Payment Status
S0317	ROLL 50317	Inactive	3.0000	2010	5	** Paid In Full

****Disclaimer:** BS&A Software provides BS&A Online as a way for municipalities to display information online and is not responsible for the content or accuracy of the data herein. This data is provided for reference only and WITHOUT WARRANTY of any kind, expressed or inferred. Please contact your local municipality if you believe there are errors in the data.

11309 FORD MI 48089 (Property Address)

Parcel Number: 12-13-34-209-026 Account Number: 201986694



Item 1 of 2 1 Image / 1 Sketch

Property Owner: IDOLSKI KAREN

Summary information

- > Residential Building Summary
 - Year Built: 1955
 - Full Baths: 1
 - Sq. Feet: 725
 - Bedrooms: 0
 - Half Baths: 0
 - Acres: 0.100
- > 20 Building Department records found

- > Assessed Value: \$26,080 | Taxable Value: \$12,790
- > 1 Special Assessment found
- > Property Tax information found
- > Utility Billing information found

Owner Information

Not Available

Amount Due

Property Total **\$0.00**

Permits

To request an inspection or pay on a record, click View

Permit Type	Permit Number	Associated Project	Status	Date Issued	Last Inspection	Amount Due	
Building	PB106584		EXPIRED	2/10/1998		\$0.00	View
FENCE	PF-19173		FINALED	8/2/2001		\$0.00	View
Special	PSP06-26446		EXPIRED	1/13/2006	1/17/2006	\$0.00	View

Displaying items 1 - 3 of 3

1

[Apply for a Permit](#)

Attachments

Date Created	Title	Record
No records to display.		

Displaying items 0 - 0 of 0

****Disclaimer:** BS&A Software provides BS&A Online as a way for municipalities to display information online and is not responsible for the content or accuracy of the data herein. This data is provided for reference only and WITHOUT WARRANTY of any kind, expressed or inferred. Please contact your local municipality if you believe there are errors in the data.

11309 FORD Warren, MI 48089 (Property Address)
 Parcel Number: 12-13-34-209-026 Account Number: 201986694

Property Owner: IDOLSKI KAREN **UB Customer Name: 201986694 OCCUPANT**



Item 1 of 2 1 Image / 1 Sketch

Summary Information
 > Residential Building Summary
 - Year Built: 1955 - Bedrooms: 0
 - Full Baths: 1 - Half Baths: 0
 - Sq. Feet: 725 - Acres: 0.100
 > 26 Building Department records found

> Assessed Value: 126,080 | Taxable Value: 112,750
 > 1 Special Assessment Found
 > Property Tax Information found
 > Utility Billing Information found

Amount Due
 Total Amount Due \$0.00
 Pay Now

Customer Information

Name: 201986694 OCCUPANT Account Number: 201986694
 Address: 11309 FORD Warren, MI 48089

Current Bill

[Click here for a printer friendly version](#)

Amount Due	Due Date	Bill From	Bill To	Previous Amount	Current Amount	Penalties & Interest	Balance
\$0.00	07/31/2023	06/01/2023	06/30/2023				
Billing Item							
PENALTY				\$0.00	\$0.00	\$0.00	\$0.00
SEWER				\$0.00	\$0.00	\$0.00	\$0.00
SEWER SERVICE CHARGE				\$0.00	\$0.00	\$0.00	\$0.00
Turn On				\$0.00	\$0.00	\$0.00	\$0.00
WATER				\$0.00	\$0.00	\$0.00	\$0.00
WATER SERVICE CHARGE				\$0.00	\$0.00	\$0.00	\$0.00

History (501 Items Found)

[Click here for a printer friendly version](#)

Starting Date: Ending Date:

Posted	Action	Other Info	Read Type	Read	Usage	Amount	Balance
7/12/2023	Bill Calculated	06/01/23-06/30/23	Auto Read	227.00	0.00	\$0.00	\$0.00
6/30/2023	Meter Read	Water		0.00	0.00	\$0.00	\$0.00
6/18/2023	Bill Calculated	04/30/23-05/01/23	Auto Read	227.00	0.00	\$0.00	\$0.00
5/1/2023	Meter Read	Water		0.00	0.00	\$0.00	\$0.00
5/12/2023	Bill Calculated	03/31/23-04/30/23	Auto Read	227.00	0.00	\$0.00	\$0.00
4/30/2023	Meter Read	Water		0.00	0.00	\$0.00	\$0.00
4/11/2023	Bill Calculated	03/01/23-03/31/23	Auto Read	227.00	0.00	\$0.00	\$0.00
3/31/2023	Meter Read	Water		0.00	0.00	\$0.00	\$0.00
3/14/2023	Bill Calculated	01/31/23-03/01/23	Auto Read	227.00	0.00	\$0.00	\$0.00
3/1/2023	Meter Read	Water		0.00	0.00	\$0.00	\$0.00
2/9/2023	Bill Calculated	12/31/22-01/31/23	Auto Read	227.00	0.00	\$0.00	\$0.00
1/31/2023	Meter Read	Water		0.00	0.00	\$0.00	\$0.00
1/13/2023	Bill Calculated	11/30/22-12/31/22					

Usage History Chart

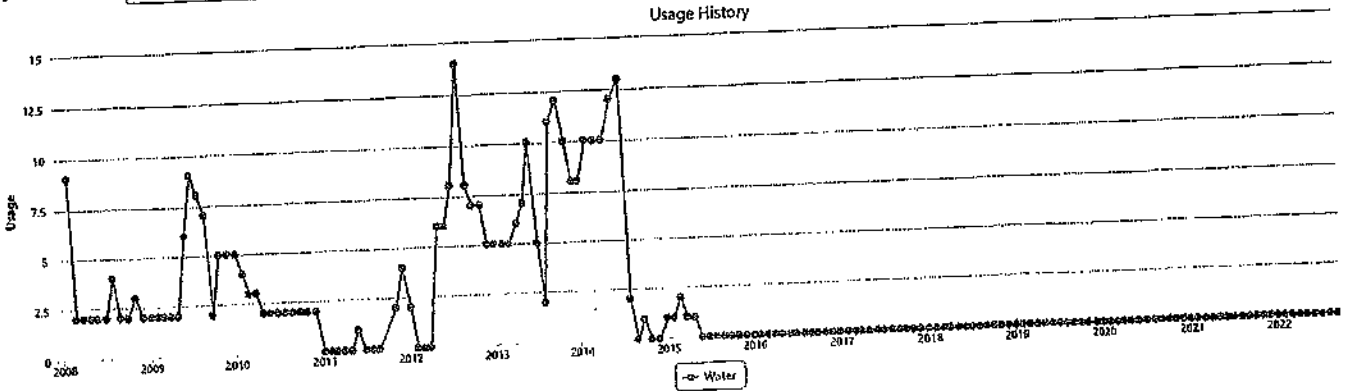

**Disclaimer: BS&A Software provides BS&A Online as a way for municipalities to display information online and is not responsible for the content or accuracy of the data herein. This data is provided for reference only and WITHOUT WARRANTY of any kind, expressed or inferred. Please contact your local municipality if you believe there are errors in the data.

11309 FORD WARREN, MI 48089 (Property Address)

Parcel Number: 12-13-34-209-026

Property Taxpayer: IDOLSKI KAREN

Summary Information

\$3.00 was charged to your Business Account for this record lookup. See [Account](#) for current balance.

Important Message

If you have questions about this payment or need assistance, please call the Macomb County Treasurer's office at (586) 469-5190. Our hours are 8 AM - 4:15 PM Monday to Friday. (These hours exclude holidays)

Owner and Taxpayer Information

Owner	IDOLSKI KAREN 22011 TEN MILE ST CLAIR SHORES, MI 48080	Taxpayer	IDOLSKI KAREN 22011 E 10 MILE RD SAINT CLAIR SHORES, MI 48080-1262
--------------	---	-----------------	---

Amount Due

Delinquent Taxes: **\$3,151.03**
[Pay Now](#)

Legal Description

Legal Description not on file.

Recalculate amounts using a different Payment Date

You can change your anticipated payment date in order to recalculate amounts due as of the specified date for this property.

Enter a Payment Date

7/27/2023

[Recalculate](#)

Tax History

Important Message

Taxpayers MUST pay the oldest tax year first

Year	Season	Total Amount	Total Paid	Last Paid	Total Due
2022	Delq. Taxes	\$1,349.80	\$0.00		\$1,349.80

Delinquent Tax Information for 2022 (All Seasons)

School District	50220	PRE/MBT	0.0000%
Taxable Value	\$12,181	S.E.V.	\$21,280
Property Class	401 - RESIDENTIAL - IMPROVED	Assessed Value	Not Available
Last Payment Date	No Data to Display	Last Receipt Number	No Data to Display
delq Tax. Base Tax Due	1238.35	Base Paid	\$0.00
Admin Fees	\$5.52	Admin Fees Paid	\$0.00
Interest Fees	\$111.45	Interest Fees Paid	\$0.00
Total Tax & Fees	\$1,349.80	Total Paid	\$0.00

Delinquent Tax Bill Breakdown for 2022

Taxing Authority	Season	Millage Rate	Local Amount	Local Amount Paid	Amount	Amount Paid
WARREN OPERATING	Summer	8.326300			\$101.42	\$0.00
CITY ROAD IMPROV	Summer	2.002900			\$24.39	\$0.00
		90.445900			\$1,349.80	\$0.00

Taxing Authority	Season	Millage Rate	Local Amount	Local Amount Paid	Amount	Amount Paid
EMS	Summer	0.277000			\$3.37	\$0.00
LIBRARY	Summer	1.268700			\$15.45	\$0.00
SANITATION	Summer	2.775000			\$33.80	\$0.00
ACT 345 POL/FIRE	Summer	4.984600			\$60.71	\$0.00
POLICE OPERATING	Summer	0.928900			\$11.31	\$0.00
FIRE OPERATING	Summer	0.928900			\$11.31	\$0.00
POL & FIRE OPER	Summer	4.674100			\$56.93	\$0.00
RECREATION	Summer	0.924700			\$11.26	\$0.00
MACOMB CNTY OPER	Summer	4.320000			\$52.62	\$0.00
MCC OPERATING	Summer	1.407700			\$17.14	\$0.00
MCC DEBT	Summer	0.000000			\$0.00	\$0.00
MAC INT SCH DIST	Summer	4.630000			\$56.39	\$0.00
STATE ED TAX	Summer	6.000000			\$73.08	\$0.00
VAN DYKE OPERAT	Summer	18.000000			\$219.25	\$0.00
VAN DYKE DEBT/SF	Summer	9.484600			\$115.53	\$0.00
SCHOOL OPER FC	Summer	18.000000			\$0.00	\$0.00
WEED	Summer	0.000000			\$309.39	\$0.00
MACOMB VETERANS	Winter	0.065200			\$0.79	\$0.00
HURON-CLINT PARK	Winter	0.207000			\$2.52	\$0.00
SMART	Winter	0.950000			\$11.57	\$0.00
ZOO AUTHORITY	Winter	0.094500			\$1.15	\$0.00
ART INSTITUTE	Winter	0.195600			\$2.38	\$0.00
Admin Fees					\$5.52	\$0.00
Interest/Fees					\$111.45	\$0.00
90.445900					\$1,349.80	\$0.00

[Click here for a printer friendly version of 2022 Delinquent Tax information](#)

2021	Delq. Taxes	\$1,801.23	\$0.00	\$1,801.23
------	-------------	------------	--------	------------

Delinquent Tax Information for 2021 (All Seasons)

School District	50220	PRE/MBT	0.0000%
Taxable Value	\$11,792	S.E.V.	\$19,470
Property Class	401 - RESIDENTIAL - IMPROVED	Assessed Value	Not Available
Last Payment Date	No Data to Display	Last Receipt Number	No Data to Display
delq Tax, Base Tax Due	1197.86	Base Paid	\$0.00
Admin Fees	\$5.40	Admin Fees Paid	\$0.00
Interest Fees	\$603.37	Interest Fees Paid	\$0.00
Total Tax & Fees	\$1,801.23	Total Paid	\$0.00

Delinquent Tax Bill Breakdown for 2021

Taxing Authority	Season	Millage Rate	Local Amount	Local Amount Paid	Amount	Amount Paid
WARREN OPERATING	Summer	8.459200			\$99.75	\$0.00
CITY ROAD IMPROV	Summer	0.000000			\$0.00	\$0.00
EMS	Summer	0.281500			\$3.31	\$0.00
LIBRARY	Summer	1.071000			\$12.62	\$0.00
SANITATION	Summer	2.819300			\$33.24	\$0.00
91.873400					\$1,801.23	\$0.00

Taxing Authority	Season	Millage Rate	Local Amount	Local Amount Paid	Amount	Amount Paid
ACT 345 POL/FIRE	Summer	4.984800			\$58.78	\$0.00
POLICE OPERATING	Summer	0.943800			\$11.12	\$0.00
FIRE OPERATING	Summer	0.943800			\$55.99	\$0.00
POL & FIRE OPER	Summer	4.748700			\$11.07	\$0.00
RECREATION	Summer	0.939500			\$51.55	\$0.00
MACOMB CNTY OPER	Summer	4.372100			\$16.80	\$0.00
MCC OPERATING	Summer	1.424700			\$0.00	\$0.00
MCC DEBT	Summer	0.000000			\$55.23	\$0.00
MAC INT SCH DIST	Summer	4.684500			\$70.75	\$0.00
STATE ED TAX	Summer	6.000000			\$212.25	\$0.00
VAN DYKE OPERAT	Summer	18.000000			\$115.92	\$0.00
VAN DYKE DEBT/SF	Summer	9.830800			\$0.00	\$0.00
SCHOOL OPER FC	Summer	18.000000			\$292.00	\$0.00
WEED	Summer	0.000000			\$0.77	\$0.00
MACOMB VETERANS	Winter	0.065000			\$2.46	\$0.00
HURON-CLINT PARK	Winter	0.208900			\$11.47	\$0.00
SMART	Winter	0.973100			\$1.12	\$0.00
ZOO AUTHORITY	Winter	0.095700			\$2.25	\$0.00
ART INSTITUTE	Winter	0.191100			\$23.99	\$0.00
ROAD REPAIRS	Winter	2.034900			\$5.40	\$0.00
Admin Fees					\$603.37	\$0.00
Interest/Fees						\$0.00
91.073400					\$1,801.23	\$0.00

[Click here for a printer friendly version of 2021 Delinquent Tax information.](#)

2020	Delq. Taxes	\$2,195.06	\$2,195.06	03/30/2023	\$0.00
2019	Delq. Taxes	\$1,956.20	\$1,956.20	03/31/2022	\$0.00
2018	Delq. Taxes	\$1,908.80	\$1,908.80	03/31/2021	\$0.00

[Load More Years](#)

****Disclaimer:** BS&A Software provides BS&A Online as a way for municipalities to display information online and is not responsible for the content or accuracy of the data herein. This data is provided for reference only and WITHOUT WARRANTY of any kind, expressed or inferred. Please contact your local municipality if you believe there are errors in the data.

Aug 12-1924

LAETHEM'S NEAR VAN DYKE SUBDIVISION

OF PART OF THE N.E. 1/4 OF SEC. 34, T. 1. N., R. 12 E.
WARREN TWP. MACOMB CO. MICHIGAN.

SCALE - 1"=200'

Note: All Dimensions are given in feet and decimals thereof.

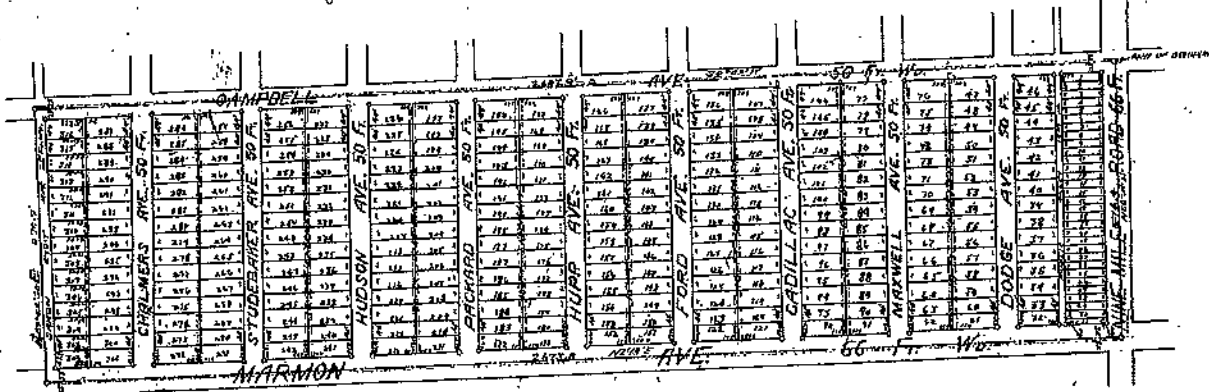

COMMISSIONER
KNOW ALL MEN BY THESE PRESENTS: That we ALBERT STRICKER and
ELIZABETH STRICKER his wife in exercise of legal title and HENRY LAETHEM,

Richard Laethem and Robert J Deschamps as purchasers under land contract have
caused the land embraced in the annexed plat to be surveyed, laid
out and platted to be known as LAETHEM'S NEAR VAN DYKE SUBDIVISION
OF PART OF THE N.E. 1/4 OF SEC. 34, T. 1. N., R. 12 E. Warren Twp.
Macomb Co. Mich and that the Streets and alleys at whom on said
plat are hereby designated to the use of the public.

Signed and tested in presence of:
Albert Stricker (L.S.)
Elizabeth Stricker (L.S.)
Henry Laethem (L.S.)
Richard Laethem (L.S.)
Robert J. Deschamps (L.S.)

STATE OF MICHIGAN
COUNTY OF MACOMB ss.

On this 5 day of June A.D. 1924
before me a Notary Public in and for said County, personally came the
above named Albert Stricker Elizabeth Stricker Henry Laethem Richard Laethem Robert J. Deschamps
Laethem and Robert J. Deschamps known to me to be the
persons who executed the above destination, and acknowledged the same to be their
free act and deed.

My commission expires May 11th 1925
William P. Stearns
Notary Public, Macomb Co. Mich.

CERTIFICATE OF TOWNSHIP BOARD

This plat was approved by the township board of Warren at a
meeting held on the 12 day of April A.D. 1924
James J. [Signature]
TOWNSHIP CLERK

DESCRIPTION OF LAND PLATTED

The land embraced in the annexed plat of LAETHEM'S NEAR VAN DYKE
SUBDIVISION of part of the N.E. 1/4 of Sec. 34 4TH 1122 Warren Twp.
Macomb Co., Mich. is bounded and described as follows:
Beginning at a point in the North line of Sec. 34 2121 R122 Macomb
Co., Mich. which is 677.68 feet S 28° 45' E from the N E corner
of said Sec. 34. Thence S 0 deg 05' W a distance of 627.9 feet.
Thence N 29 deg. 44' 30" E a distance of 670.7 feet. Thence N E 2 deg.
18' E a distance of 2973.8 feet. Thence N 80 deg. 22' E a distance of
676.4 feet to the point of beginning.

ENGINEER'S CERTIFICATE

I hereby certify that the plat hereon delineated is a correct one,
and that permanent monuments consisting of 1" iron gas pipe 16" long
and that permanent monuments consisting of 1" iron gas pipe 16" long
have been planted at points marked thus (O) as they are shown at all
angles in the boundaries of the land platted, and at all intersections
of streets or streets and alleys.

H. R. [Signature]
REGISTERED CIVIL ENGINEER

COUNTY TREASURER'S CERTIFICATE

This plat was approved by the County Board for Macomb
County, Michigan, at a meeting held Aug 8, 1924
[Signature]
Deputy

This plat was approved by the County Board for Macomb
County, Michigan, at a meeting held Aug 8, 1924
[Signature]
Deputy

REGISTER'S OFFICE COUNTY OF MACOMB

Recorded for Book 12 Page 123
at 12 A.D. 1924
in the Warren and Warren
Twp. of Macomb
County, Michigan.
[Signature]



REC'D MACOMB CO *13APR02PM1029

RET'D. FOR CORR. APR 2 2013

REC'D MACOMB CO *14JAN31PM0154

4011722 Page 1 of 2
LIBER 22662 PAGE 224
01/31/2014 01:56:38 PM
Macomb County, MI
Carmelia Sabaugh, Clerk/Register of Deeds
Receipt # 5056

SEAL

This is to certify that according to the County of
Treasurer's records there are no liens or encumbrances
on this property and that the same have not been paid
for five years prior to the date on this instrument
except 20 No. 133, TED B. WAHBY
Macomb County Treasurer BY
This certification does not include current taxes now
being collected. Date 1/31/14



REAL ESTATE ★
TRANSFER TAX ★
\$11.00 CO ★
\$75.00 ST ★
001193446 ★

Above Space Reserved for Recording

(If required by your jurisdiction, list above the name & address of: 1) where to return this form; 2) preparer; 3) party requesting recording.)

Warranty Deed

Date of this Document: 10/03/2012

Reference Number of Related Documents: _____

Grantor(s):
Name Danica Anderson
Street Address 28096 Waverly St
City/State/Zip Roseville MI 48066

Grantee(s):
Name Karen Edolski
Street Address 22011 East Ten Mile Road
City/State/Zip Saint Clair Shores MI 48080

Abbreviated Legal Description (i.e., lot, block, plat, or section, township, range, quarter/quarter or unit, building and
condo name): Laethem's near Van Dyke subdivision DA
LOT 125 L8 P11 CITY OF WARREN, COUNTY OF MACOMB,
Assessor's Property Tax Parcel/Account Number(s): 13-34-209-026 STATE OF MICHIGAN

For good consideration, \$10,000.00 ten thousand dollars
Danica Anderson
of 28096 Waverly Roseville MI 48066 County of Macomb
State of Michigan, hereby bargain, deed and convey to Karen Edolski
of 22011 East Ten Mile St Clair Shores MI
County of Macomb State of Michigan the following described land in
Macomb County, free and clear with WARRANTY COVENANTS; to wit: 11309 Ford
Warren MI 48089
Laethem's near Van Dyke subdivision lot 125
L8 P11

z LSH

C

Grantor, for itself and its heirs, hereby covenants with Grantee, its heirs, and assigns, that Grantor is lawfully seized in fee simple of the above-described premises; that it has a good right to convey; that the premises are free from all encumbrances; that Grantor and its heirs, and all persons acquiring any interest in the property granted, through or for Grantor, will, on demand of Grantee, or its heirs or assigns, and at the expense of Grantee, its heirs or assigns, execute any instrument necessary for the further assurance of the title to the premises that may be reasonably required; and that Grantor and its heirs will forever warrant and defend all of the property so granted to Grantee, Its heirs, and assigns, against every person lawfully claiming the same or any part thereof.

Being the same property conveyed to the Grantor by deed of 11309 Ford Warren MI dated 49089
October 3rd, 20 12

WITNESS the hands and seal of said Grantor this 3rd day of October, 2012

D Anderson
Grantor

Danica Anderson
Grantor

State of Michigan
County of Macomb

Judy M. Vermillion Notary

On October 3 2012 before me, Danica Anderson, personally appeared Danica Anderson, personally known to me (or proved to me on the basis of satisfactory evidence) to be the person(s) whose name(s) is/are subscribed to the within instrument and acknowledged to me that he/she/they executed the same in his/her/their authorized capacity(ies), and that by his/her/their signature(s) on the instrument the person(s), or the entity upon behalf of which the person(s) acted, executed the instrument.

WITNESS my hand and official seal.

Signature [Handwritten Signature]

Affiant Known Unknown
ID Produced ✓ DL-A536-135-585-788

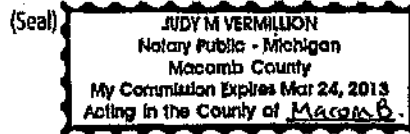

Drafted by: Danica Anderson
3878 Franklin Dr
Clinton Twp MI
48036

E-RECORDED RECEIVED
REGISTER OF DEEDS
MACOMB COUNTY, MI
2023 APR 04 1:02 PM

202300028953 L: 29071 P: 184 Pages: 1
04/04/2023 01:23 PM Fees: \$30.00
Anthony G. Forlini, Clerk/Register of Deeds
Macomb County, MI



Michigan Department of Treasury
3626 (Rev. 04-21)

CERTIFICATE OF FORFEITURE OF REAL PROPERTY
Issued under the authority of Public Act 206 of 1983; MCL 211.78g

On March 1, 2023 the following real property was forfeited to the **MACOMB**
County Treasurer for **NON PAYMENT OF REAL PROPERTY TAXES** for the
year(s) **2021**

If the 2021 taxes are not paid by March 31, 2024, absolute title to the property and any equity associated with an interest in the property will vest in the foreclosing governmental unit, as provided by MCL 211.78k. If the property is foreclosed and sold or transferred, MCL 211.78t provides that a party with an interest in the property at the time of a judgment of foreclosure may claim interest in any remaining proceeds following the sale or transfer.

Property ID No. 12-13-34-209-026	
Owner According to Tax Record IDOLSKI KAREN	
Property Address 11309 FORD WARREN MI	Amount for Which Property Forfeited \$ 1,729.35
Property Description LATHEM'S NEAR VAN DYKE SUBDIVISION (L6, P11); LOT 125	
Prepared by FRANK KRYCIA ASSISTANT CORPORATION COUNSEL ONE SOUTH MAIN - 8TH FLOOR MT CLEMENS MI 48043	Signature of County Treasurer <i>Lawrence Rocca</i> County Treasurer Name Printed LAWRENCE ROCCA

REC'D MACOMB CO *23 JUN 2 AM 9 22

202300048415 L: 29152 P: 379 Pages: 1
06/02/2023 09:32 AM Fees: \$30.00
Anthony G. Forlani, Clerk/Register of Deeds
Macomb County, MI



Claim of Lien

7022 0410 0000 0153 4348 9590 9402 7367 2028 8433 16

The undersigned claims a lien for \$500 against the personal property of 11309 Ford Ave, Warren, Michigan 48089

LAETHEM'S NEAR VAN DYKE SUBDIVISION (L8, P11); LOT 125

As collateral for the satisfaction of debt now due as of FEBRUARY 13, 2022 by lien debtor Karen IDolski for landscaping, labor, and yard improvements in accordance with lien claimants security agreement.

And now, within THREE days after completion of the work, the undersigned records this claim of lien in the office of the clerk of Macomb County Register of Deeds in the county where the property is located and certifies that the owner has been sent a copy of this claim of lien by certified mail on 7022 1670 0003 1976 7800

This claim of lien expires and is void 365 days from the date of the filing of the claim of lien if so Notice of Commencement of Lien Action is filed in that time period.

*First day of labor February 3, 2022
Last day of labor February 12, 2022*

STATE OF MICHIGAN
COUNTY OF MACOMB

I, Marwan Williams being duly sworn, affirms and states as follows: I am the claimant above named; I have read or heard the forgoing claim and know the contents thereof, and believe the same to be true and correct and that the claim of lien is not frivolous and is made with reasonable cause, and is not clearly excessive under penalty of perjury

Drafted by Marwan Williams 8452 Rivard Warren Michigan 48086

State of Michigan
County of Macomb

[Signature]
Marwan Williams

Given under my hand and Seal on this 1 day of June, 2023

[Signature]
Notary Public
My commission expires 2-8-28

AMANDA R. DIEGEL
NOTARY PUBLIC - STATE OF MICHIGAN
COUNTY OF MACOMB
My Commission Expires Feb. 8, 2028
Acting in the County of Macomb

C

CITY OF WARREN
Office of the Council Secretary

Item 11a

INTER-OFFICE COMMUNICATION

DATE: April 9, 2024

TO: David Muzzarelli, Public Service Director

SUBJECT: PUBLIC HEARING: (Tabled 2/13/2024) Request to approve the demolition of a house and shed at 7551 Prospect through the nuisance abatement program. CONSIDERATION AND ADOPTION OF A RESOLUTION.

At a Regular meeting of the City Council held Tuesday, April 9, 2024, Council made the formal motion to remove this item from the table, after discussion with Mr. Paul Lize, the Council made the formal motion to re-Table the item to May 28, 2024.

Trusting this information to be of value.



Mindy Moore
Council Secretary

cc: Attorney
Building
Clerk
Mayor

CITY OF WARREN
Office of the Council Secretary

Item 11c

INTER-OFFICE COMMUNICATION

DATE: February 13, 2024

TO: Public Service Director
Lorie Barnwell, City Treasurer

SUBJECT: PUBLIC HEARING: Request to approve the demolition of a house and shed at 7551 Prospect through the nuisance abatement program. CONSIDERATION AND ADOPTION OF A RESOLUTION.

At a Regular meeting of the City Council held Tuesday, February 13, 2024, Council made the formal motion to table the above listed item to April 9, 2024 to allow owners time to make progress on the property and make the request that a report on current tax status be provided to Council from the City Treasurer on this and all future nuisance abatements.

Trusting this information to be of value.



Mindy Moore
Council Secretary

cc: Attorney
Clerk
Mayor



December 12, 2023

DEPARTMENT OF PUBLIC SERVICE
ONE CITY SQUARE, SUITE 320
WARREN, MI 48093-5284
(586) 574-4604
FAX (586) 574-4517
www.cityofwarren.org

Mindy Moore, Council Secretary

RE: Resolution for 7551 Prospect (house and shed) Nuisance Abatement

Honorable Council Secretary:

The approval of a resolution is necessary for the demolition of a house and shed at 7551 Prospect which is under the nuisance abatement program.

Attached, please find the appropriate resolution and place on the January 9, 2024 consent agenda for a February 13, 2024 City Council Meeting.

Thank you for your cooperation in this matter.

Sincerely,

A handwritten signature in blue ink that reads "Gus Ghanam".

Gus Ghanam, Director
Department of Public Service

Read and Concur,

A handwritten signature in blue ink that reads "Laura Sullivan".

Approved:

City Attorneys Office

Read and Concur,

A handwritten signature in blue ink that reads "Lori M. Stone".

Approved:

Lori M. Stone, Mayor

RDS/al
Cc: Mayor
Building

**Nuisance Abatement
7551 Prospect
13-33-428-023**

RESOLUTION APPROVING PUBLIC NUISANCE DETERMINATION

A regular meeting of the council of the City of Warren, County of Macomb, Michigan, held on _____ at 7 p.m. Eastern _____ Time, in the council chamber of the Warren Community Center, 5460 Arden, Warren, Michigan.

PRESENT: Council Members _____

ABSENT: Council Members _____

The following preamble and resolution were offered by Council Member

_____ and supported by Council Member _____:

On **July 27, 2023** a hearing was held before the Hearing Officer for the City of Warren to determine whether a nuisance exists in violation of Section 9-165 thru 9-175 of the Warren Code of Ordinances upon the following described property: **7551 Prospect**

Parcel No. **13-33-428-023**

Known as : **LOT 121 – LEO A. TEMROWSKI'S SUBDIVISION, according to the plat thereof as recorded in liber 7, Page 92 of Plats Macomb County Records.**

The Hearing Officer determined that a public nuisance did in fact exist on the subject Property indicated in violation of the Code of Ordinances, Chapter 9, Article VI, Division 2 to wit:

Warren Code of Ordinances paragraph:

8. **A building or structure, including the adjoining grounds, used or intended to be used for dwelling purposes, because of dilapidation, decay, damage, faulty construction, arrangement, or is otherwise unsanitary or unfit for human habitation, is in a condition that the code official, health officer or designated representative determines is likely to cause sickness or disease, or is likely to injure the health, safety, or general welfare of people living in the dwelling.**

- 10: **A building or structure that remains unoccupied for a period of one hundred eighty (180) consecutive days or longer, and is not listed as being available for sale, lease, or rent with a real estate broker licensed under Article 25 of the Occupational Code, Act No. 299 of the Public Acts of 1980.**

Determination: Unfit for human habitation and remains unoccupied.

The Hearing Officer has ordered the nuisance be abated by demolition. The City Clerk has notified the subject property's owner(s), occupant(s), or other interested parties, and all property owners or occupants located within three hundred (300) feet of the subject property, of the Hearing Officer's Order of determination of the existence of a public nuisance, and of the date, time and location of the Hearing Officer's Appeal Hearing.

On this date stated above, the council of the City of Warren held an Appeal Hearing of the Hearing Officer's determination that a nuisance exists upon the subject property.

NOW, THEREFORE, IT IS RESOLVED, that after due consideration, it is the opinion of the council of the City of Warren that the determination of the Hearing Officer shall be approved that the **vacant dilapidated one story house (802 sq. ft.) with crawl space and shed 12 ft. x 20 ft. at: 7551 Prospect** has created a dangerous condition as defined by Section 9-165 thru Section 9-175, which constitutes a public nuisance, and shall be abated in accordance with the Order of the Hearing Officer.

IT IS FURTHER RESOLVED, that the nuisance shall be abated within sixty (60) days of this Appeal Hearing date, and if the nuisance is not abated within the time limit, the Director of Public Service is hereby instructed to direct the removal of the nuisance by the proper

department of the City.

IT IS FURTHER RESOLVED, that the demolition bid awarded to the lowest priced qualified contractor, who meets the bid specifications, is hereby approved.

IT IS FURTHER RESOLVED, that the owner(s) of the subject property is hereby notified that a charge for these nuisance proceedings, which includes all administrative costs and costs incurred by the City's personnel or private contractor(s), will be incurred and owed to the City.

IT IS FURTHER RESOLVED, that the Director of Public Service shall keep an accurate record of all expenses incurred in connection with the removal of the nuisance. Upon the completion of any work performed to remove the nuisance, the Director of Public Service shall bill the subject Property's owner(s) for the amount owed, which shall be paid to the City within thirty (30) days.

IT IS FURTHER RESOLVED, that if the expenses incurred by the City in connection with the removal of the nuisance are not paid within the time specified, the City Attorney's Office will be directed to institute collection proceedings, including but not limited to, any civil action that may be available. Accordingly, the Director of Public Service shall charge a special assessment, (SAR) against the subject property for any unpaid nuisance removal expenses.

IT IS FURTHER RESOLVED, that the City Clerk shall record a certified copy of this Resolution Approving Public Nuisance Determination with the Macomb County Register of Deeds.

IT IS FURTHER RESOLVED, that after the removal of the nuisance, the Director of Public Service shall record a Certificate of Removal of Notice of Nuisance Abatement Proceedings with the Macomb County Register of Deeds.

AYES: Council Members

NAYS: Council Members

RESOLUTION DECLARED ADOPTED this _____ day of _____, 2024.

Mindy Moore, Secretary of the Council

CERTIFICATION

STATE OF MICHIGAN)
) SS.
COUNTY OF MACOMB)

I, SONJA BUFFA, duly elected City Clerk for the City of Warren, Macomb County, Michigan, hereby certifies that the foregoing is a true and correct copy of the resolution adopted by the council of the City of Warren at its meeting held on _____, 2024.

SONJA BUFFA
City Clerk

When recorded return to:
One City Square
City Clerk, Suite 205
Warren, Michigan 48093-2393

Reviewed by:
City Attorney's Office
One City Square
Legal Department, Suite 400
Warren, Michigan 48093-5285

NUISANCE ABATEMENT - Dangerous Buildings
Warren Code of Ordinances Chapter 9, Article VI, Division 1 and 2

SPECIFICS FOR CITY COUNCIL

Date 12/7/2023

Property Address 7551 Prospect Owners Name Mary C Morehart
Sidwell 12-13-33-428-023 Owners Address 2673 Hendrie
Subdivision Leo A Temrowski's sub lot 121 L.7 P.92 Owners City Detroit Zip 48211
Date of Complaint/Discovery 2/13/2023 Agent _____
Ord. Sec. 9-165, Par, Violation #8 & #10 Agent Address _____

Specifics:

- 1 Vacant dilapidating home/ home at time of Unsafe Structure posting- in tax foreclosure
- 2 Owner continually granted time to make repairs (4 separate hearings, insufficient progress)
- 3 Rear roof remains tarped with water damage at rear roof, overhang and wall (see att pics)
- 4 Zero water usage since 9/30/2023 , No city certs or repair permits issued.
- 5 Failing front porch covered with plywood with patio blocks. Dilapidated shed structure at rear.
- 6 Several previous blight violations with property maintenance.

Building Size 802 sq. ft. Type Exterior metal siding Story 1

Has: foundation, piers, crawl space, basement crawl space

Accessory Building Size(s)

- 1 Garages
- 2 Sheds 12 ft. x 20 ft. accessory structure
- 3 Other

Lot Size 35 ft. x 155 ft.

Utilities Connected gas pinned off, zero water-turned off delinquent, possible DTE service

Date of Nuisance Abatement Hearing 3/23,4/27,5/25, and 7/27/2023

Owner or representative appearing at hearing Mary Morehart (owner) appeared at all hearings

Date/Postings

- 1 Unsafe structure 2/13/2023 Posted Unsafe Structure
- 2 No Occupancy - C/O required 4/30/2020 Posted vacant for City Certification
- 3 Stop work
- 4 Re-postings

City Certification inspections obtained None / Failed to register vacant (VPR) or obtain City Certification

Permits obtained, Inspections performed

- 1 Building
- 2 Electrical
- 3 Mechanical
- 4 Plumbing

Assessed Value \$32,940 Length of Vacancy 4 years Year Home Built 1941

Taxes paid/pending due, taxes believed paid enough to retain property from tax foreclosure.

Comments & Other Removal: Remove 12 ft. x 20 ft. accessory structure



02/13/2023 11:29



7551

02/13/2023 11:29



7551

02/13/2023 11:29



Additional pictures for
Public Service & Mayor

02/13/2023 11:34



Additional pictures for
Public Service & Mayor

02/13/2023 11:34



Additional pictures for
Public Service & Mayor

02/13/2023 11:31



Additional pictures for
Public Service & Mayor

02/13/2023 11:31



Additional pictures for
Public Service & Mayor

02/13/2023 11:30

Additional pictures for
Public Service & Mayor

02/13/2023 11:31



Additional pictures for
Public Service & Mayor

02/13/2023 11:31



Additional pictures for
Public Service & Mayor

02/13/2023 11:33





CITY OF
WARREN
586-775-1400

WESTLAND
A COMMUNITY MISSION
www.CityofWestland.com
RECYCLABLES ONLY

Additional pictures for
Public Service & Mayor

02/13/2023 11:33



Additional pictures for
Public Service & Mayor

05/22/2023 12:24



Additional pictures for
Public Service & Mayor

05/22/2023 12:22



WESTLAND
MISSION GREEN
RECYCLABLES ONLY

05/22/2023 12:23

Original Pictures for
Public Service & Safety



7551

Additional pictures for
Public Service & Mayor

05/22/2023 12:23



Additional pictures for
Public Service & Mayor

05/22/2023 12:22



NO TRASHING

Additional pictures for
Public Safety & Mayor

05/22/2023 12:23



Additional pictures for
Public Service & Mayor

06/13/2023 11:37



Additional pictures for
Public Service & Mayor

06/13/2023 11:35



Additional pictures for
Public Services & Mayor

06/13/2023 11:37



Additional pictures for
Public Service & Mayor

06/13/2023 11:36



Additional pictures for
Public Service & Mayor

06/13/2023 11:35



Additional pictures for
Public Service & Mayor

06/13/2023 11:36



Additional
Public Service

07/18/2023 11:16



Additional pictures for
Public Service & Mayor

07/18/2023 11:17

Additional pictures for
Public Service & Mayor

07/18/2023 11:17



Additional pictures for
Public Service & Mayor

07/18/2023 11:17



Additional pictures for
Public Services/Mayor

07/18/2023 11:17



Additional pictures for
Public Service & Mayor

07/18/2023 11:19



Additional pictures for
Public Service & Mayor

07/18/2023 11:18



07/18/2023 11:18

Additional pictures for
Public Service & Mayor



Additional pictures for
Public Service & Mayor

10/19/2023 12:43



7551

Additional pictures for
Public Service & Mayor

10/19/2023 12:43



Additional pictures for
Public Service & Mayor

10/19/2023 12:44



Additional pictures for
Public Service & Mayor

10/19/2023 12:44



Additional pictures for
Public Service & Mayor

10/19/2023 12:44



Additional pictures for
Public Service & Mayor

10/19/2023 12:44

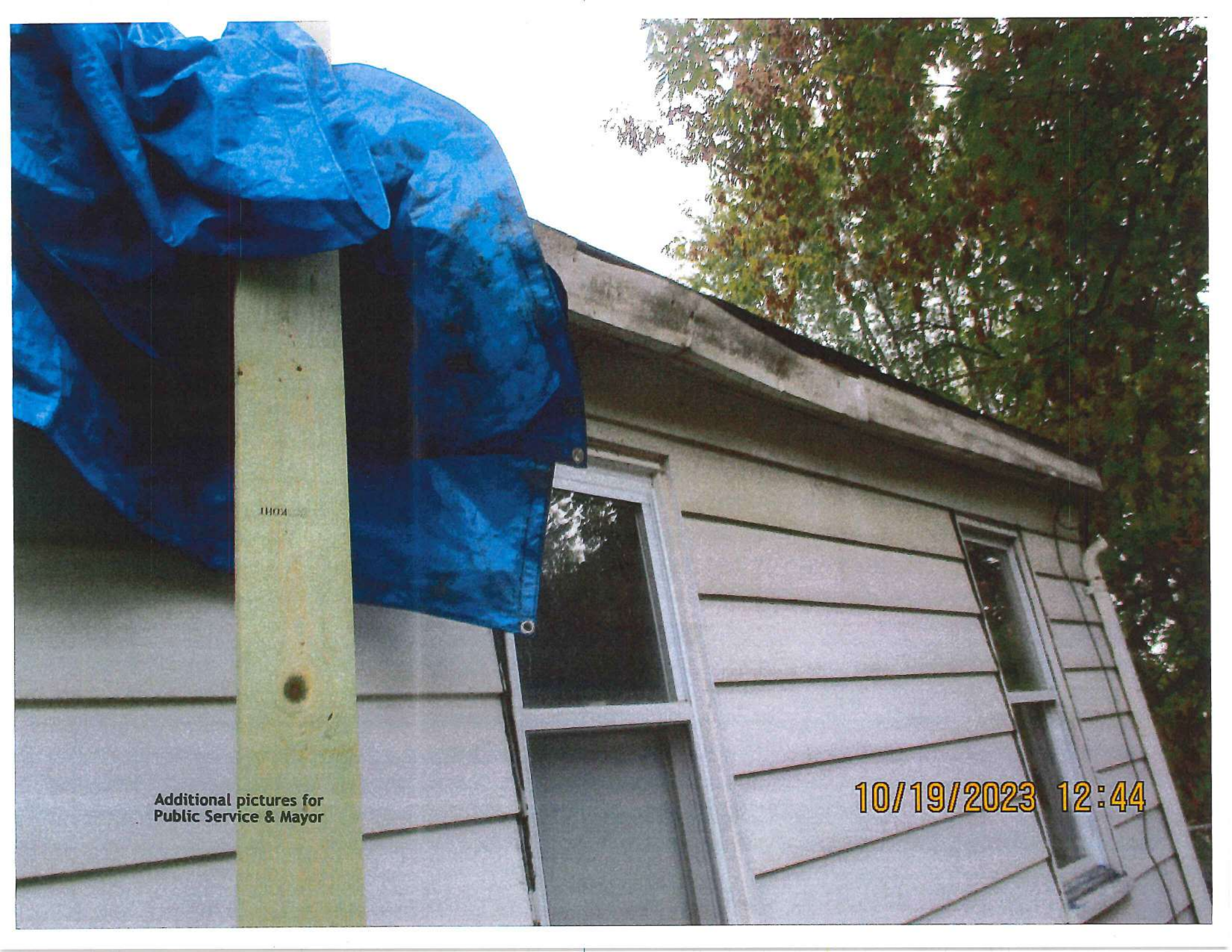

KOHL

Additional pictures for
Public Service & Mayor

10/19/2023 12:44



10/19/2023 12:45

Additional pictures at
Public Services - Mayo

CITY OF WARREN
ORDER
ABATEMENT BY DEMOLITION

To: Hearing Attendees

Re: Administrative Hearing - Property Maintenance Ordinance

Division of Buildings and Safety Engineering

Officer: Gus Ghanam

Date: July 27, 2023

Title: Acting Hearing Officer

Property Description:

Name: Robert Lambert

Address: 7551 Prospect Warren MI 48091 House

Legal Description: LEO A. TEMROWSKI'S SUBDIVISION LOT 121

Tax I.D. Number: 12-13-33-428-023

Recorded in Liber: 7 Page: 92 of Macomb County Records

Owner:

Mailing Name: Mary C Morehart

Address Address: 2673 Hendrie St

City: Detroit State: MI Zip: 48211

Attorney/Agent: _____

An administrative hearing was held regarding the described property of the above date. The following conditions exist on this property, which make abatement by demolition necessary.

- 1.) 8: A building or structure, including the adjoining grounds, used or intended to be used for dwelling purposes, because of dilapidation, decay, damage, faulty construction, arrangement, or is otherwise unsanitary or unfit for human habitation, is in a condition that the code official, health officer or designated representative determines is likely to cause sickness or disease, or is likely to injure the health, safety, or general welfare of people living in the dwelling.
- 2.) 10: A building or structure that remains unoccupied for a period of one hundred eighty (180) consecutive days or longer, and is not listed as being available for sale, lease, or rent with a real estate broker licensed under Article 25 of the Occupational Code, Act No. 299 of the Public Acts of 1980.

DETERMINATION: unfit for human habitation & remains unoccupied. It has been determined that this property cannot be restored to a condition necessary to meet the Ordinance requirements of the City of Warren in an economical manner. Based on the findings of this hearing, it is ordered that the nuisance as determined be abated by demolition no later than August 27, 2023.

Date

The owner is hereby notified that he/she is responsible to comply with this Order and is responsible for any and all administrative, boarding, demolition, clean up, or other costs incurred by the City to eliminate the dangerous condition of this property due to the owner's failure to comply with this Order.

Pursuant to Ordinance, Section 9-172, you may appeal the determination and order of the Hearing Officer to the City Council by filing a written notice of appeal with the Division of Buildings and Safety Engineering before the date specified for compliance.

In concurrence:

Paul Lize,
Chief Building Inspector

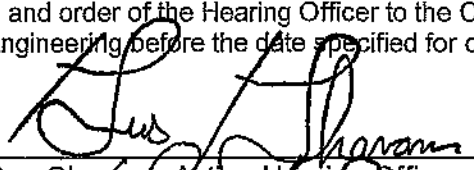
Gus Ghanam, Acting Hearing Officer

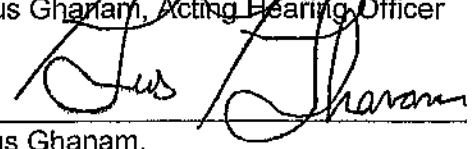
Gus Ghanam,
Department of Public Service

cc: **Attendees**
Director of Public Service

CITY OF WARREN

NOTICE OF NUISANCE ABATEMENT PROCEEDINGS

An Administrative Hearing was held on July 27, 2023 at One City Square, Warren, Michigan, between the Hearing Officer for the City of Warren, County of Macomb, State of Michigan, and the last-recorded owner of the property described as:

Owners Name: Mary C Morehart
Property address: 7551 Prospect Warren MI 48091 House
Property description: LEO A. TEMROWSKI'S SUBDIVISION LOT 121
Tax I.D. Number: 12-13-33-428-023
Recorded in Liber: 7, Page: 92 of Macomb County Records

WHEREAS, it has been brought to the attention of the City of Warren that the owner of the above-described property has permitted a dangerous condition to exist, to wit:

- 1.) 8: A building or structure, including the adjoining grounds, used or intended to be used for dwelling purposes, because of dilapidation, decay, damage, faulty construction, arrangement, or is otherwise unsanitary or unfit for human habitation, is in a condition that the code official, health officer or designated representative determines is likely to cause sickness or disease, or is likely to injure the health, safety, or general welfare of people living in the dwelling.
- 2.) 10: A building or structure that remains unoccupied for a period of one hundred eighty (180) consecutive days or longer, and is not listed as being available for sale, lease, or rent with a real estate broker licensed under Article 25 of the Occupational Code, Act No. 299 of the Public Acts of 1980.

and such conditions may endanger the health and welfare of the citizens in the immediate area; and specific conditions being: **unfit for human habitation and remains unoccupied.**

WHEREAS, after investigation by the Division of Buildings and Safety Engineering of the City of Warren, after testimony was received and after due consideration, the Hearing Officer for the City of Warren has determined that a dangerous condition exists in violation of Sec. 9-165 or 9-166 of the Code of Ordinances and has ordered abatement pursuant to Chapter 9, Article VI, Division 2, Sec. 9-165 thru 9-175, of the City of Warren Code of Ordinances.

NOW, THEREFORE, BE IT KNOWN that any prospective buyer or assignee be on notice that the City of Warren has declared a nuisance to exist and ordered abatement pursuant to Article VI, Chapter 9 of the Code of Ordinances of the City of Warren.

BE IT FURTHER KNOWN that any prospective buyer or assignee of the above-described property may contact the Division of Buildings and Safety Engineering, located at One City Square, Warren, Michigan, and be informed of any pending action on said property.

BE IT FURTHER KNOWN that the City Clerk shall record a certified copy of this notice with the Macomb County Register of Deeds.

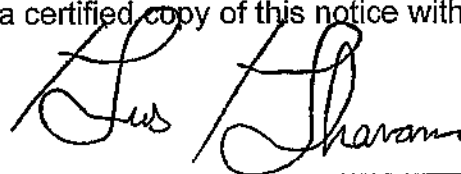

Gus Ghanam, Acting Hearing Officer

CERTIFICATION

STATE OF MICHIGAN)
) SS.
COUNTY OF MACOMB)

I, Sonja Buffa, duly-elected City Clerk for the City of Warren, Macomb County, Michigan, hereby certify that the foregoing is a true and correct copy of the Lis Pendens: Notice of Nuisance Abatement Proceedings.

Sonja Buffa
City Clerk

Drafted and Returned to:
City Clerk
City of Warren
One City Square, #205
Warren, MI 48093-2393

BUILDING DIVISION
NUISANCE ABATEMENT MINUTES
July 27, 2023

In attendance:

Paul Lize, Building Inspector
Laura Sullivan, Assistant City Attorney

The meeting was called to order by Gus Ghanam, Acting Hearing Officer.

11291 Paige (12-13-27-459-027) House & Garage All parties have been duly notified and letters were posted on the building in question. Caleb Shureb, attorney for Wells Fargo appeared.

Mr. Ghanam stated that there have been many complaints about sewage smell being pumped out of basement and owner is deceased.

DETERMINATION:

Mr. Ghanam declared public nuisance, send to Public Service for demolition.

Audience Participation

Neighbors from surrounding properties spoke about sewage smell, and dilapidated state of house. Stated after owners passing, property was abandoned.

7551 Prospect (12-13-33-428-023) House All parties have been duly notified and letters were posted on the building in question. Owner, Mary Morehart appeared.

Mr. Ghanam stated that the property has not shown any significant progress regarding clean up or repair.

DETERMINATION:

Mr. Ghanam declared public nuisance, send to Public Service for demolition.

Audience Participation

None

COLONIAL TITLE COMPANY

27500 Harper Ave.
St. Clair Shores, MI 48081
Phone: (586)774-5950
Fax: (586)774-7040

FAX COVER LETTER

To: Mandy Wells
Company Name: City of Warren - Building Division
Fax No.: (586)574-4577
Email: mwells@cityofwarren.org
Customer No.: 2320719
Date: February 16, 2023
From: Courtney

Property Address: 7551 Prospect, Warren, MI 48091

File No.: 23921

Message: Attached is your requested search and invoice. Please call Colonial Title Company with any questions or problems you may have. Thank you for your business.

ADDITIONAL COMMENTS:

Invoice

Remit payment to:

Colonial Title Company
27500 Harper Ave.
St. Clair Shores, MI 48081

Billed to:

City of Warren - Building Division
One City Square, Suite 305
Warren, MI 48091

Invoice number: 23921

Invoice date: February 16, 2023

Please pay before: March 2, 2023

Our file number: 23921

Your reference number: 2320719

Property:

7551 Prospect
Warren, MI 48091
Macomb County

DESCRIPTION	AMOUNT
Title Search	85.00
Invoice total amount due:	\$ 85.00

**COLONIAL TITLE COMPANY
SEARCH REPORT**

Record Search Furnished to: Mandy Wells
City of Warren - Building Division
One City Square, Suite 305
Warren, MI 48091

Customer Reference Number: 2320719

This search consists of entries recorded with the Office of the Register of Deeds, based upon legal description herein.

This is not a Title Insurance Policy, and should not be relied upon as such. **THIS IS NOT AN "ENVIRONMENTAL SEARCH"**.

In consideration of the issuance of this search, it is agreed that Colonial Title Company, shall not be liable for any loss of damage arising from incorrectness or incompleteness of this search unless such incorrectness or incompleteness is the result of the intentional omission or misdescription by the Company, with the formed intent of harming the applicant of the search. In no event, as evidenced by the charge for this search, does Colonial Title Company undertake any liability arising from:

1. Consequential or punitive damages, loss of anticipated profits, costs of toxic waste cleanup or other loss so related;
2. Any type of loss which would result from the accuracy of a determination that any street address given and legal description searched constitute the same premises;
3. Any instrument (however designated) filed in the Office of the Register of Deeds pursuant to the Uniform Commercial Code P.A. 1962, No. 174, effective January 1, 1964; and/or
4. Any records of the Circuit, Probate or other Courts nor any records other than the records in the Office of the Register of Deeds.

Covering property described as: 7551 Prospect, Warren, MI 48091

We have searched the records in the Office of the Register of Deeds for Macomb County and find no conveyances describing said property in said office up to February 2, 2023 at 8:00am.

See attached Rider "B"

Colonial Title Company
Stephen DeBates, President

RIDER "B"
SEARCH OF TITLE

From examination of the records in the Register of Deeds Office, Macomb County, Michigan, up to February 2, 2023 at 8:00am.

PROPERTY DESCRIPTION:

Land Situated in the City of Warren, County of Macomb and State of Michigan described as follows:

Lot 121 - Leo A. Temrowski's Subdivision, according to the plat thereof as recorded in Liber 7, Page 92 of Plats, Macomb County Records.

Commonly Known As: 7551 Prospect, Warren, MI 48091

Tax ID Number: 12-13-33-428-023

Apparent Owner: Jeffery P. Adams and Mary K. Morehart
Title Deed dated 09/11/2015, recorded 09/11/2015, in Liber 23612, Page 638, Macomb County Records.

NOTE: There is a discrepancy in the chain of title regarding the name of the prior owner. The apparent owners were deeded the property by Rhonda Adams LaValley, however she took title as Rhonda Kay Adams via Quit Claim Deed recorded 11/05/2009, in Liber 20012, Page 941, Macomb County Records. Further evidence is needed to prove that Rhonda Adams LaValley and Rhonda Kay Adams are one and the same individual, and to correct the discrepancy in the chain of title.

PAYMENT OF TAXES: Tax Parcel No.: 12-13-33-428-023
Address: 7551 Prospect, Warren, MI 48091
2022 Winter Taxes in the amount of \$15.08 are DUE
2022 Summer Taxes in the amount of \$731.06 are DUE
2021 Taxes in the amount of \$650.17 are DELINQUENT
2020 Taxes in the amount of \$2,060.10 are DELINQUENT
Special Assessments Included In The Current Year Tax Bills: NONE
Special Assessments Separate From the Tax Bills: MUST VERIFY WITH CITY
- 2022 State Equalized Value: \$20,820.00
- 2022 Taxable Value: \$9,898.00

No open mortgages found recorded on the public record.

Certificate of Forfeiture filed by the Macomb County Treasurer for non payment of the 2020 taxes dated 03/01/2022, recorded 03/23/2022 in Liber 28511, Page 534, Macomb County Records.

Under this form of Search, this Company is not an insurer of the above Title, nor does it guarantee the Title or any evidence thereto and is not liable for any inaccuracies involving environmental searches or determinations.

The liability is limited to the amount paid for the Search. Rider attached to and forming a part of Search No. 23921

Colonial Title Company
Stephen DeBates, President

7551 PROSPECT WARREN, MI 48091 (Property Address)

Parcel Number: 12-13-33-42B-023 Account Number: 202924090



Item 1 of 2 1 Image / 1 Sketch

Property Owner: ADAMS JEFFERY P & MOREHART MARY C

Summary Information

- > Residential Building Summary
 - Year Built: 1941
 - Full Baths: 1
 - Sq. Feet: 802
 - Bedrooms: 0
 - Half Baths: 0
 - Acres: 0.125
- > 18 Building Department records found
- > Assessed Value: \$20,820 | Taxable Value: \$9,898
- > 1 Special Assessment found
- > Property Tax information found
- > Utility Billing information found

Owner and Taxpayer Information

Owner ADAMS JEFFERY P & MOREHART MARY C
 7551 PROSPECT
 WARREN, MI 48091

Taxpayer SEE OWNER INFORMATION

General Information for Tax Year 2022

Property Class	401 RESIDENTIAL-IMPROVED	Unit	12 CITY OF WARREN
School District	VAN DYKE PUBLIC SCHOOLS	Assessed Value	\$20,820
Notes	NEZ - Patriot Place	Taxable Value	\$9,898
PP CLASS / YEAR	0	State Equalized Value	\$20,820
NOTES	Not Available	Date of Last Name Change	01/17/2023
BUSINESS TYPE	Not Available	Notes	Not Available
Historical District	Not Available	Census Block Group	Not Available
NOTES	Not Available	Exemption	No Data to Display

Principal Residence Exemption Information

Homestead Date 09/11/2015

Principal Residence Exemption	June 1st	Final
2022	100.0000 %	0.0000 %

Previous Year Information

Year	MBOR Assessed	Final SEV	Final Taxable
2021	\$18,160	\$18,160	\$9,582
2020	\$17,170	\$17,170	\$9,450
2019	\$14,440	\$14,440	\$9,280

Land Information

Zoning Code	R-1-C	Total Acres	0.125
Land Value	\$4,020	Land Improvements	\$0
Renaissance Zone	No	Renaissance Zone Expiration Date	No Data to Display
ECF Neighborhood	VAN DYKE 33	Mortgage Code	No Data to Display
Lot Dimensions/Comments	Not Available	Neighborhood Enterprise Zone	No

Lot(s)	Frontage	Depth
Lot 1	35.00 ft	155.00 ft
Total Frontage: 35.00 ft		Average Depth: 155.00 ft

Legal Description

LEO A. TEMROWSKI'S SUBDIVISION LOT 121 L7 P92

Date of Last Split/Combine	No Data to Display	Number of Splits Left	0
Date Form Filed	No Data to Display	Unallocated Div.s of Parent	0
Date Created	01/01/0001	Unallocated Div.s Transferred	0
Acreage of Parent	0.00	Rights Were Transferred	Not Available
Split Number	0	Courtesy Split	Not Available
Parent Parcel	No Data to Display		

Sale History

Sale Date	Sale Price	Instrument	Grantor	Grantee	Terms of Sale	Liber/Page
09/11/2015	\$1.00	QC	ADAMS LAVALLEY RHONDA	ADAMS JEFFERY P & MOREHART MARY K	33-TO BE DETERMINED	23612/638
10/27/2009	\$1.00	QC	COOLAHAN VIOLA	ADAMS RHONDA	33-TO BE DETERMINED	20012/941

Building Information - 802 sq ft 1 Story (Residential)

General

Floor Area	802 sq ft	Estimated TCV	Not Available
Garage Area	0 sq ft	Basement Area	0 sq ft
Foundation Size	802 sq ft	Year Remodeled	No Data to Display
Year Built	1941	Class	CD
Occupancy	Single Family	Tri-Level	No
Effective Age	59 yrs	Heat	Forced Air w/ Ducts
Percent Complete	100%	Wood Stove Add-on	No
AC w/Separate Ducts	No	Water	Not Available
Basement Rooms	0	Sewer	Not Available
1st Floor Rooms	5	Style	1 Story
2nd Floor Rooms	0		
Bedrooms	0		

Area Detail - Basic Building Areas

Height	Foundation	Exterior	Area	Heated
1 Story	Crawl Space	Siding	802 sq ft	1 Story

Basement Finish

Recreation	0 sq ft	Recreation % Good	0%
Living Area	0 sq ft	Living Area % Good	0%
Walk Out Doors	0	No Concrete Floor Area	0 sq ft

Plumbing Information

3 Fixture Bath	1
----------------	---

**Disclaimer: BS&A Software provides BS&A Online as a way for municipalities to display information online and is not responsible for the content or accuracy of the data herein. This data is provided for reference only and WITHOUT WARRANTY of any kind, expressed or inferred. Please contact your local municipality if you believe there are errors in the data.

Copyright © 2023 BS&A Software, Inc.

7551 PROSPECT WARREN, MI 48091 (Property Address)

Parcel Number: 12-19-33-428-023 Account Number: 202924090



Item 1 of 2 1 Image / 1 Sketch

Property Owner: ADAMS JEFFERY P & MOREHART MARY C

Summary Information

- > Residential Building Summary
 - Year Built: 1941
 - Full Baths: 1
 - Sq. Feet: 802
 - Bedrooms: 0
 - Half Baths: 0
 - Acres: 0.125
- > 18 Building Department records found
- > Assessed Value: \$20,820 | Taxable Value: \$9,898
- > 1 Special Assessment found
- > Property Tax Information found
- > Utility Billing Information found

Owner and Taxpayer Information

Owner ADAMS JEFFERY P & MOREHART MARY C
 Taxpayer SEE OWNER INFORMATION
 7551 PROSPECT WARREN, MI 48091

Amount Due

Current Taxes: **\$746.14**
 Pay Now

Legal Description

LEO A. TEMROWSKI'S SUBDIVISION LOT 121 L7 P92

Other Information

Recalculate amounts using a different Payment Date

You can change your anticipated payment date in order to recalculate amounts due as of the specified date for this property.

Enter a Payment Date

2/16/2023

Recalculate

Tax History

****Note:** On March 1 at 12:00 AM, Summer and Winter local taxes become ineligible for payment at the local unit.

Year	Season	Total Amount	Total Paid	Last Paid	Total Due	
2022	Winter	\$15.08	\$0.00		\$15.08	Pay Now

General Information for 2022 Winter Taxes

School District	50220	PRE/MBT	0.0000%
Taxable Value	\$9,898	S.E.V.	\$20,820
Property Class	401 - RESIDENTIAL-IMPROVED	Assessed Value	\$20,820
Tax Bill Number	No Data to Display	Last Receipt Number	No Data to Display
Last Payment Date	No Data to Display	Number of Payments	0
Due Date	No Data to Display		
Base Tax	\$14.94	Base Paid	\$0.00
Admin Fees	\$0.14	Admin Fees Paid	\$0.00
Interest Fees	\$0.00	Interest Fees Paid	\$0.00
Total Tax & Fees	\$15.08	Total Paid	\$0.00
Renaissance Zone	Not Available	Mortgage Code	Not Available

Taxing Authority	Millage Rate	Amount	Amount Paid
MACOMB VETERANS	0.065200	\$0.64	\$0.00
HURON-CLINT PARK	0.207000	\$2.04	\$0.00
SMART	0.950000	\$9.40	\$0.00
ZOO AUTHORITY	0.094500	\$0.93	\$0.00
ART INSTITUTE	0.195600	\$1.93	\$0.00
Admin Fees		\$0.14	\$0.00
Interest Fees		\$0.00	\$0.00
	1.512300	\$15.08	\$0.00

[Click here for your Winter 2022 Tax Bill](#)

[Click here for a printer friendly version of Winter 2022 Tax information](#)

2022	Summer	\$731.06	\$0.00	\$731.06	Pay Now
------	--------	----------	--------	----------	---------

General Information for 2022 Summer Taxes

School District	50220	PRE/MBT	0.0000%
Taxable Value	\$9,898	S.E.V.	\$20,820
Property Class	401 - RESIDENTIAL-IMPROVED	Assessed Value	\$20,820

Tax Bill Number	No Data to Display	Last Receipt Number	No Data to Display
Last Payment Date	No Data to Display	Number of Payments	0
Due Date	08/31/2022		

Base Tax	\$702.01	Base Paid	\$0.00
Admin Fees	\$4.33	Admin Fees Paid	\$0.00
Interest Fees	\$24.72	Interest Fees Paid	\$0.00
Total Tax & Fees	\$731.06	Total Paid	\$0.00

Renaissance Zone	Not Available	Mortgage Code	Not Available
------------------	---------------	---------------	---------------

Tax Bill Breakdown for 2022 Summer

Taxing Authority	Millage Rate	Amount	Amount Paid
WARREN OPERATING	8.326300	\$82.41	\$0.00
CITY ROAD IMPROV	2.002900	\$19.82	\$0.00
EMS	0.277000	\$2.74	\$0.00
LIBRARY	1.268700	\$12.55	\$0.00
SANITATION	2.775000	\$27.46	\$0.00
ACT 345 POL/FIRE	4.984800	\$49.33	\$0.00
POLICE OPERATING	0.928900	\$9.19	\$0.00
FIRE OPERATING	0.928900	\$9.19	\$0.00
POL & FIRE OPER	4.674100	\$46.26	\$0.00
RECREATION	0.924700	\$9.15	\$0.00
MACOMB CNTY OPER	4.320000	\$42.75	\$0.00
MCC OPERATING	1.407700	\$13.93	\$0.00
MAC INT SCH DIST	4.630000	\$45.82	\$0.00
STATE ED TAX	6.000000	\$59.38	\$0.00
VAN DYKE OPERAT	18.000000	\$178.16	\$0.00
VAN DYKE DEBT/SF	9.484600	\$93.87	\$0.00
Admin Fees		\$4.33	\$0.00
		\$24.72	\$0.00
		70.933600	\$731.06
			\$0.00

By continuing to use this website you agree to the [BS&A Online Terms of Use](#). X

[Click here for your Summer 2022 Tax Bill](#)

[Click here for a printer friendly version of Summer 2022 Tax information](#)

2021	Winter	\$34.32	\$0.00	\$34.32	** Read Note(s) Above
2021	Summer	\$513.33	\$0.00	\$513.33	** Read Note(s) Above
2020	Winter	\$15.70	\$0.00	\$15.70	** Read Note(s) Above
2020	Summer	\$1,268.27	\$0.00	\$1,268.27	** Read Note(s) Above
2019	Winter	\$14.63	\$0.00	\$14.63	** Read Note(s) Above
2019	Summer	\$522.11	\$0.00	\$522.11	** Read Note(s) Above
2018	Winter	\$14.46	\$0.00	\$14.46	** Read Note(s) Above
2018	Summer	\$502.25	\$0.00	\$502.25	** Read Note(s) Above
2017	Winter	\$14.09	\$0.00	\$14.09	** Read Note(s) Above
2017	Summer	\$493.25	\$0.00	\$493.25	** Read Note(s) Above

[Load More Years](#)

****Disclaimer:** BS&A Software provides BS&A Online as a way for municipalities to display information online and is not responsible for the content or accuracy of the data herein. This data is provided for reference only and WITHOUT WARRANTY of any kind, expressed or inferred. Please contact your local municipality if you believe there are errors in the data.

Copyright © 2023 BS&A Software, Inc.

7551 PROSPECT WARREN, MI 48091 (Property Address)

Parcel Number: 12-13-33-428-023 Account Number: 202924090



Item 1 of 2 1 Image / 1 Sketch

Property Owner: ADAMS JEFFERY P & MOREHART MARY C

Summary Information

- > Residential Building Summary
 - Year Built: 1941
 - Full Baths: 1
 - Sq. Feet: 802
 - Bedrooms: 0
 - Half Baths: 0
 - Acres: 0.125
- > 18 Building Department records found
- > Assessed Value: \$20,820 | Taxable Value: \$9,898
- > 1 Special Assessment found
- > Property Tax information found
- > Utility Billing information found

Owner and Taxpayer Information

Owner ADAMS JEFFERY P & MOREHART MARY K
 Taxpayer 7551 PROSPECT WARREN, MI 48091
 SEE OWNER INFORMATION

Amount Due

Special Assessment Total Payoff Amount: \$0.00

Legal Description

Legal Description not on file.

Special Assessment Information

Code	Name	Special Assessment District Status	APR Interest Rate	Start Year	Number of Years	Payment Status
S0266	ROLL S0266	Inactive	3.0000	2007	5	** Paid in Full

**Disclaimer: BS&A Software provides BS&A Online as a way for municipalities to display information online and is not responsible for the content or accuracy of the data herein. This data is provided for reference only and WITHOUT WARRANTY of any kind, expressed or inferred. Please contact your local municipality if you believe there are errors in the data.

Copyright © 2023 BS&A Software, Inc.

7551 PROSPECT MI 48091 (Property Address)

Parcel Number: 12-13-33-428-023 Account Number: 202924090



Item 1 of 2 1 Image / 1 Sketch

Property Owner: ADAMS JEFFERY P & MOREHART MARY C

Summary Information

- > Residential Building Summary
 - Year Built: 1941
 - Full Baths: 1
 - Sq. Feet: 802
 - Bedrooms: 0
 - Half Baths: 0
 - Acres: 0.125
- > 18 Building Department records found
- > Assessed Value: \$20,820 | Taxable Value: \$9,898
- > 1 Special Assessment found
- > Property Tax Information found
- > Utility Billing Information found

Owner Information

Not Available

Amount Due	
Property Total	\$0.00

Permits

To pay on a record, click View

Permit Type	Permit Number	Associated Project	Status	Date Issued	Last Inspection	Amount Due	
Building	PB139626		EXPIRED	6/26/2000		\$0.00	View

Displaying items 1 - 1 of 1



[Apply for a Permit](#)

Attachments

Date Created	Title	Record
No records to display.		

Displaying items 0 - 0 of 0

**Disclaimer: BS&A Software provides BS&A Online as a way for municipalities to display information online and is not responsible for the content or accuracy of the data herein. This data is provided for reference only and WITHOUT WARRANTY of any kind, expressed or inferred. Please contact your local municipality if you believe there are errors in the data.

Copyright © 2023 BS&A Software, Inc.

7551 PROSPECT Warren, MI 48091 (Property Address)

Parcel Number: 12-13-33-428-029 Account Number: 202924090

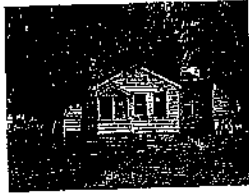

Item 1 of 2 1 Image / 1 Sketch

Property Owner: ADAMS JEFFERY P & MOREHART MARY C
OCCUPANT

UB Customer Name: 202924090

Summary Information

- > Residential Building Summary
 - Year Built: 1941
 - Bedrooms: 0
 - Full Baths: 1
 - Half Baths: 0
 - Sq. Feet: 802
 - Acres: 0.125
- > 18 Building Department records found

- > Assessed Value: \$20,820 | Taxable Value: \$9,898
- > 1 Special Assessment found
- > Property Tax Information found
- > Utility Billing Information found

Customer Information

Name: 202924090 OCCUPANT
Address: 7551 PROSPECT Warren, MI 48091
Account Number: 202924090

Amount Due

Total Amount Due \$0.00
Pay Now

Current Bill

[Click here for a printer friendly version](#)

Amount Due	\$0.00	Bill From	12/31/2022		
Due Date	02/28/2023	Bill To	01/31/2023		
Billing Item	Previous Amount	Current Amount	Penalties & Interest	Balance	
DELINQ NOTICE FEE	\$0.00	\$0.00	\$0.00	\$0.00	
PENALTY	\$0.00	\$0.00	\$0.00	\$0.00	
Register	\$0.00	\$0.00	\$0.00	\$0.00	
SEWER	\$0.00	\$0.00	\$0.00	\$0.00	
SEWER SERVICE CHARGE	\$0.00	\$0.00	\$0.00	\$0.00	
STATE MANDATED FEE	\$0.00	\$0.00	\$0.00	\$0.00	
Turn On	\$0.00	\$0.00	\$0.00	\$0.00	
WATER	\$0.00	\$0.00	\$0.00	\$0.00	
WATER SERVICE CHARGE	\$0.00	\$0.00	\$0.00	\$0.00	

History (588 Items Found)

Starting Date Ending Date

[Click here for a printer friendly version](#)

Posted	Action	Other Info	Read Type	Read	Usage	Amount	Balance
2/9/2023	Bill Calculated	12/31/22-01/31/23		0.00	0.00	\$0.00	\$0.00
1/31/2023	Meter Read	Water	Estimate	378.00	0.00	\$0.00	\$0.00
1/11/2023	Bill Calculated	11/30/22-12/31/22		0.00	0.00	\$0.00	\$0.00
12/31/2022	Meter Read	Water	Estimate	378.00	0.00	\$0.00	\$0.00
12/12/2022	Bill Calculated	10/31/22-11/30/22		0.00	0.00	\$0.00	\$0.00
11/30/2022	Meter Read	Water	Estimate	378.00	0.00	\$0.00	\$0.00
11/14/2022	Bill Calculated	09/30/22-10/31/22		0.00	0.00	\$0.00	\$0.00
10/31/2022	Meter Read	Water	Estimate	378.00	0.00	\$0.00	\$0.00
10/12/2022	Bill Calculated	08/31/22-09/30/22		0.00	0.00	\$0.00	\$0.00
9/30/2022	Meter Read	Water	Estimate	378.00	0.00	\$0.00	\$0.00
9/13/2022	Bill Calculated	07/31/22-08/31/22		0.00	0.00	\$0.00	\$0.00
8/31/2022	Meter Read	Water	Estimate	378.00	0.00	\$0.00	\$0.00
8/12/2022	Bill Calculated	06/30/22-07/31/22		0.00	0.00	\$0.00	\$0.00

Usage History Chart

Usage History

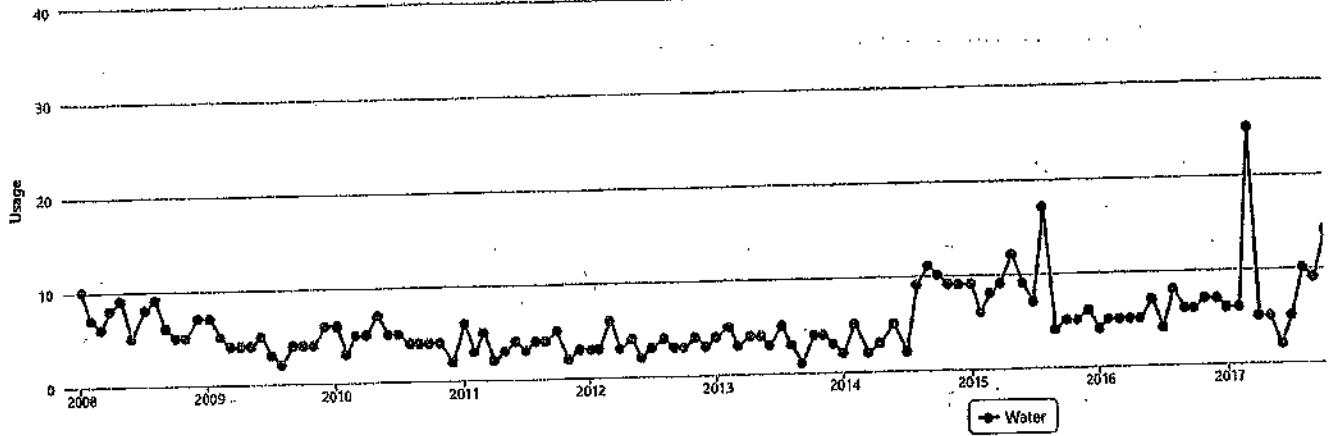

**Disclaimer: BS&A Software provides BS&A Online as a way for municipalities to display information online and is not responsible for the content or accuracy of the data herein. This data is provided for reference only and WITHOUT WARRANTY of any kind, expressed or inferred. Please contact your local municipality if you believe there are errors in the data.

Copyright © 2023 BS&A Software, Inc.

7551 PROSPECT WARREN, MI 48091 (Property Address)

Parcel Number: 12-13-33-428-023

Property Taxpayer: ADAMS JEFFERY P & MOREHART MARY K

Summary Information

Important Message

If you have questions about this payment or need assistance, please call the Macomb County Treasurer's office at (586) 469-5190. Our hours are 8 AM - 4:30 PM on Monday, Tuesday, Thursday and Friday. We have extended hours on Wednesdays, from 8 AM to 7 PM, for payments only. (These hours exclude holidays)

Owner and Taxpayer Information

Owner	ADAMS JEFFERY P & MOREHART MARY K 7551 PROSPECT WARREN, MI 48091	Taxpayer	ADAMS JEFFERY P & MOREHART MARY K 7551 PROSPECT AVE WARREN, MI 48091- 2918
-------	---	----------	--

Amounts Due

Enroll in Recurring Payments
Delinquent Taxes: **\$2,710.27**
[Pay Now](#)
PRE Audit: **Not Available**

Legal Description

Legal Description not on file.

Recalculate amounts using a different Payment Date

You can change your anticipated payment date in order to recalculate amounts due as of the specified date for this property.

Enter a Payment Date

2/16/2023

Recalculate

Tax History

Year	Season	Total Amount	Total Paid	Last Paid	Total Due
2021	Diq. Taxes	\$650.17	\$0.00		\$650.17
2020	Diq. Taxes	\$2,159.89	\$99.79	01/04/2022	\$2,060.10
2019	Diq. Taxes	\$1,100.21	\$1,100.21	01/04/2022	\$0.00
2018	Diq. Taxes	\$1,094.84	\$1,094.84	04/02/2021	\$0.00
2017	Diq. Taxes	\$1,128.29	\$1,128.29	01/05/2021	\$0.00

Load More Years

P.R.E. Audit Information

Audit #	Denial Year	Total	Paid	Balance
1	2022	\$216.88	\$0.00	\$216.88

**Disclaimer: BS&A Software provides BS&A Online as a way for municipalities to display information online and is not responsible for the content or accuracy of the data herein. This data is provided for reference only and WITHOUT WARRANTY of any kind, expressed or inferred. Please contact your local municipality if you believe there are errors in the data.

July 3-1927
Leo A. Temrowski

LEO A TEMROWSKI'S SUBDIVISION

OF PART OF THE S.E. 1/4 OF SEC. 33 T. 1 N., R. 12 E.
WARREN TWP. MACOMB CO. MICH.

L 7
P 92

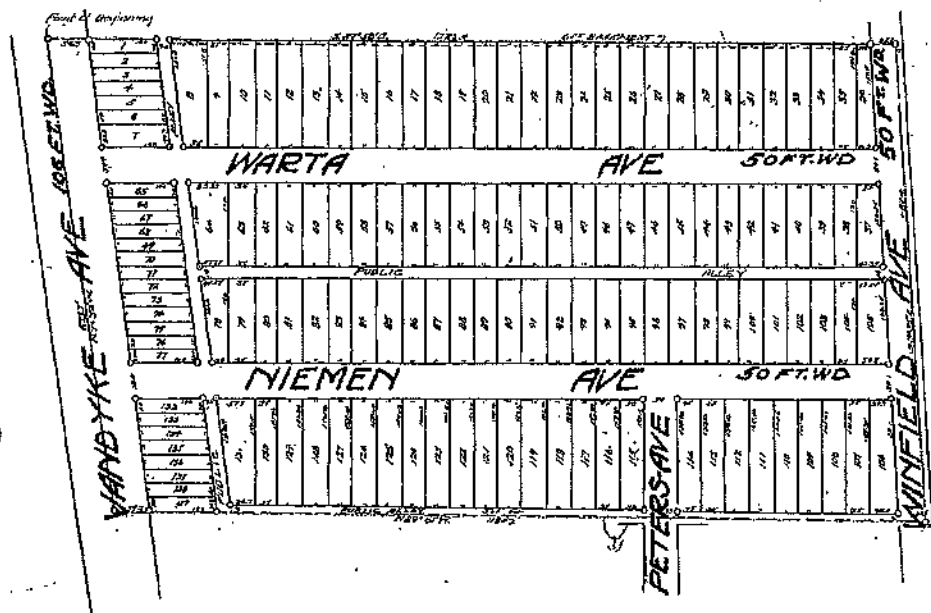

THE S.E. 1/4 OF SEC. 33, T. 1 N., R. 12 E.,
WARREN TWP., MACOMB CO., MICH.
LEO A. TEMROWSKI, of
Warren Twp., Macomb Co., Mich.
do hereby certify that the above described
lots and lots in the parcel of
Warren Twp., Macomb Co., Mich.
have been divided into lots as shown on this plat and are hereby dedicated to the use of the public.

This plat was approved by the township of Warren at a special meeting held on the 22nd day of July, 1927.

On this 24th day of May A.D. 1927 before me, a Notary Public in and for said county, personally appeared the above named Leo A. Temrowski, who acknowledged to me that he executed the above described plat and that he is the person who executed the same and acknowledged the same to be true and correct.

COUNTY TREASURER
This is to certify that the tax on the above described lots has been paid to the County Treasurer of Macomb County, Michigan, for the year 1927.

NOTARY PUBLIC
I hereby certify that the above described plat was duly recorded in the office of the County Clerk of Macomb County, Michigan, on the 24th day of May, 1927.

I hereby certify that the plat hereto delineated is a correct copy of the original plat on file in my office and that the same has been duly recorded in the office of the County Clerk of Macomb County, Michigan, on the 24th day of May, 1927.

Notary Public
Notary Public
Notary Public

DESCRIPTION OF LAND PLATED
The land included in the annexed plat of LEO A. TEMROWSKI'S SUBDIVISION of part of the S.E. 1/4 of Sec. 33 T. 1 N., R. 12 E., Warren Twp., Macomb Co., Mich. is described as follows to wit: Beginning at a point N. 75° 26' N., a distance of 1702.52 ft. from the S.E. corner of Sec. 33 T. 1 N., R. 12 E., County of Macomb, State of Michigan, thence N. 75° 26' N., a distance of 682.5 ft. to the point of beginning.

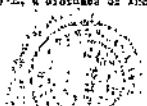

RECD MACOMB CO *15SEP11PM0132

5113132 Page 1 of 1
LIBER 23612 PAGE 638
09/11/2015 01:35:51 PM
Macomb County, MI SEAL
Carmella Sabaugh, Clerk/Register of Deeds
Receipt # 55248

QUIT CLAIM DEED

KNOW ALL MEN BY THESE PRESENTS: That Rhonda Adams LaValley
whose address is: 7551 prospect ave warren mi 48091

Quit Claim to: Jeffery P. Adams & Mary K Morehart
whose address is: 7551 prospect Ave, Warren, MI 48091

The following described premises situated in the City of Warren, County of
Macomb and State of Michigan, to-wit: (Cite "See attached property description" if description does not fit in space below).

Lot 121 LEOA. Temrawslets Sub Liber. 7 Page 92

Parcel Identification No.: 13-33-428-023

Commonly known as:

Together with all and singular the tenements, hereditaments and appurtenances thereunto belonging or in anywise appertaining, for the
sum of \$ 100 - 00

Dated this 11 day of Sept, 20 15

Signed by:

Rhonda Adams LaValley

Rhonda Adams LaValley

STATE OF MICHIGAN

COUNTY OF Wayne

The foregoing instrument was acknowledged before me this 11 day of September, 20 15 by

Rhonda Adams LaValley

Barbie Smith

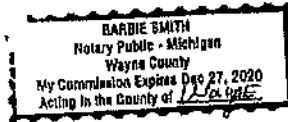

Notary Public

Wayne County, Michigan

Acting in Wayne County, Michigan

My commission expires: 12-27-20

WHEN RECORDED RETURN TO:

DRAFTED BY: Mary Morehart
7551 Prospect Ave
Warren, mi 48091

1ms

e

REC'D MACOMB CO *09NOV05PM0110



11/05/2009 01:17:53 P.M. SEAL
MACOMB COUNTY, MI
CARMELLA SABAUGH, REGISTER OF DEEDS

QUIT CLAIM DEED

KNOW ALL MEN BY THESE PRESENTS: That VIOLA COOLAHAN, formerly known as VIOLA LYLE ✓

whose address is: 27382 Kaufman, Roseville, MI 48066

Quit Claims to: RHONDA KAY ADAMS

whose address is: 7551 Prospect, Warren, MI 48091

the following described premises situated in the City of Warren, County of Macomb and State of Michigan, to-wit:

Lot 121, Leo A. Temrowski's Subdivision of part of the Southeast Quarter (1/4) of Section 33, Town 1 North Range 12 East, according to the plat thereof as recorded in Liber 7 of Plats, Page 92, Macomb County Records ✓

Parcel Identification No. 13-33-428-023 ✓
Commonly known as: 7551 Prospect ✓

together with all and singular the tenements, hereditaments and appurtenances thereunto belonging or in anywise appertaining, for the sum of ONE AND 00/100 DOLLAR (\$1.00).

This Deed is exempt from Michigan County Real Estate Transfer Tax by virtue of MCLA 207.505(a) and State Real Estate Transfer Tax by virtue of MCLA 207.526(a).

Dated this 27th day of October, 2009.

Signed by:
Viola Coolahan
VIOLA COOLAHAN, formerly known as VIOLA LYLE

STATE OF MICHIGAN)
)SS
COUNTY OF MACOMB)

The foregoing instrument was acknowledged before me this 27th day of October, 2009 by VIOLA COOLAHAN, formerly known as VIOLA LYLE.

Jaqueline Palazzolo
Jaqueline Palazzolo, Notary Public
Macomb County, MI
My Commission Expires: 03/28/2013
Acting in Macomb County

Drafted by: KATHLEEN S. SCHULTZ, ESQ., 24405 Gratiot Avenue, Eastpointe, MI 48021

When Recorded Return to:
Rhonda Kay Adams
7551 Prospect
Warren, MI 48091

Send Subsequent Tax Bills to:
GRANTEE

Tax Parcel # _____ Recording Fee _____ Revenue Stamps 0



Michigan Department of Treasury
3626 (Rev. 04-21)

CERTIFICATE OF FORFEITURE OF REAL PROPERTY

issued under the authority of Public Act 206 of 1983; MCL 211.78g

On March 1, 2022 the following real property was forfeited to the MACOMB County Treasurer for NON PAYMENT OF REAL PROPERTY TAXES for the year(s) 2020

If the 2020 taxes are not paid by March 31, 2023, absolute title to the property and any equity associated with an interest in the property will vest in the foreclosing governmental unit, as provided by MCL 211.78k. If the property is foreclosed and sold or transferred, MCL 211.78t provides that a party with an interest in the property at the time of a judgment of foreclosure may claim interest in any remaining proceeds following the sale or transfer.

Property ID No. 12-13-33-428-023	
Owner According to Tax Record ADAMS JEFFERY P & MOREHART MARY K	
Property Address 7551 PROSPECT WARREN MI	Amount for Which Property Forfeited \$ 1,743.74
Property Description LEO A. TEMROWSKI'S SUBDIVISION (L7, P92); LOT 121	
Prepared by FRANK KRYCIA ASSISTANT CORPORATION COUNSEL ONE SOUTH MAIN - 8TH FLOOR MT CLEMENS MI 48043	Signature of County Treasurer 
	County Treasurer Name Printed LAWRENCE ROCCA

- ZERO WATER SINCE 9/30/2019

Status: ACTIVE-NO BILL Service Address: [REDACTED]
 Cycle: Warren Route/Book: [REDACTED]

Services: **2. Service History** | 3. Usage Chart | 4. Backflow Valves | 5. Taps & Curb Box | 6. Linked Applications | 7. Misc

Read Date	Action	Service	Read	Usage	Type
11/30/2023	Meter Read	Water	0.00	0.00	Misc
10/31/2023	Meter Read	Water	0.00	0.00	Auto
9/29/2023	Meter Read	Water	0.00	0.00	Auto
8/1/2023	Meter Read	Water	0.00	0.00	Auto
7/31/2023	Meter Read	Water	0.00	0.00	Auto
5/20/2023	Meter Read	Water	0.00	0.00	Auto
4/1/2023	Meter Read-In bal	Water	0.00	0.00	Act
3/1/2023	Meter Head Change	Water	378.00	0.00	Act
5/31/2023	Meter Read	Water	378.00	0.00	Est
5/1/2023	Meter Read	Water	378.00	0.00	Est
3/31/2023	Meter Read	Water	378.00	0.00	Est
2/28/2023	Meter Read	Water	378.00	0.00	Est
1/31/2023	Meter Read	Water	378.00	0.00	Est
12/31/2022	Meter Read	Water	378.00	0.00	Est
11/30/2022	Meter Read	Water	378.00	0.00	Est
10/31/2022	Meter Read	Water	378.00	0.00	Est
9/30/2022	Meter Read	Water	273.00	0.00	Est
8/31/2022	Meter Read	Water	273.00	0.00	Est
7/31/2022	Meter Read	Water	273.00	0.00	Est
6/30/2022	Meter Read	Water	273.00	0.00	Est
5/31/2022	Meter Read	Water	273.00	0.00	Est
4/30/2022	Meter Read	Water	273.00	0.00	Est
3/31/2022	Meter Read	Water	273.00	0.00	Est
2/29/2022	Meter Read	Water	273.00	0.00	Est
1/31/2022	Meter Read	Water	273.00	0.00	Est
12/31/2021	Meter Read	Water	273.00	0.00	Est
11/30/2021	Meter Read	Water	273.00	0.00	Est

Status: ACTIVE-NO BILL
Cycle: Warren

Service Address: 1281 660 STREET
Route/Book:

Services | 2. Service History | 3. Usage Chart | 4. Backflow Values | 5. Taps & Curb Box | 6. Linked Applications | 7. Misc

Read Date	Action	Service	Read	Usage	Type
6/31/2021	Meter Read	Water	378.00	0.00	Est
7/31/2021	Meter Read	Water	378.00	0.00	Est
8/31/2021	Meter Read	Water	378.00	0.00	Est
9/31/2021	Meter Read	Water	378.00	0.00	Est
10/31/2021	Meter Read	Water	378.00	0.00	Est
11/31/2021	Meter Read	Water	378.00	0.00	Est
12/31/2021	Meter Read	Water	378.00	0.00	Est
1/31/2022	Meter Read	Water	378.00	0.00	Est
2/28/2022	Meter Read	Water	378.00	0.00	Est
3/31/2022	Meter Read	Water	378.00	0.00	Est
4/30/2022	Meter Read	Water	378.00	0.00	Est
5/31/2022	Meter Read	Water	378.00	0.00	Est
6/30/2022	Meter Read	Water	378.00	0.00	Est
7/31/2022	Meter Read	Water	378.00	0.00	Est
8/31/2022	Meter Read	Water	378.00	0.00	Est
9/30/2022	Meter Read	Water	378.00	0.00	Est
10/31/2022	Meter Read	Water	378.00	0.00	Est
11/30/2022	Meter Read	Water	378.00	0.00	Est
12/31/2019	Meter Read	Water	378.00	0.00	Est
11/30/2019	Meter Read	Water	378.00	0.00	Est
10/31/2019	Meter Read	Water	378.00	0.00	Est
9/30/2019	Meter Read	Water	378.00	0.00	Auto
8/30/2019	Meter Read	Water	378.00	1.00	Auto
7/31/2019	Meter Read	Water	378.00	20.00	Auto

Status: ACTIVE-NO BILL
Cycle: Warren

Service Address: 2211 FALCON
Route/Book:

Add Edit

Number	Status	Type	Date Filed	Scheduled Date / Due Date	Completed Date / Result
21-051100		T/OFF DELINQUENT	10/01/2020	12/00 AM	10/01/2020
21-051100		T/OFF DELINQUENT	11/01/2020	12/00 AM	COMPLETED
23-059172		METER INSPECTION	5/1/2023	9:30 AM	5/1/2023
23-059172		METER INSPECTION	5/01/2023	N/A	COMPLETED
23-059146	Completed	METER INSPECTION	5/31/2023	12:00 AM	5/31/2023
23-059146		METER INSPECTION	5/29/2023	5/29/2023	CANCELLED
22-051078	Completed	VERIFY ON/OFF	5/7/2022	12:00 AM	5/7/2022
22-051078		VERIFY ON/OFF	5/03/2022	5/7/2022	COMPLETED
21-045670	Completed	VERIFY ON/OFF	5/25/2021	12:00 AM	5/25/2021
21-045670		VERIFY ON/OFF	5/14/2021	N/A	COMPLETED
20-040778	Completed	VERIFY ON/OFF	2/5/2020	12:00 AM	2/10/2020
20-040778		VERIFY ON/OFF	01/07/20	N/A	COMPLETED
19-035535	Completed	T/OFF DELINQUENT	2/5/2019	12:00 AM	2/5/2019
19-035535		T/OFF DELINQUENT	7/01/2019	N/A	COMPLETED
19-035424	Completed	T/OFF DELINQUENT	4/15/2018	12:00 AM	4/15/2018
19-035424		T/OFF DELINQUENT	4/10/2018	N/A	COMPLETED
19-032541	Completed	T/OFF DELINQUENT	12/5/2018	12:00 AM	12/5/2018
19-032541		T/OFF DELINQUENT	11/29/2018	12/5/2018	COMPLETED
19-032415	Completed	T/OFF DELINQUENT	7/25/2018	12:00 AM	7/25/2018
19-032415		T/OFF DELINQUENT	7/20/2018	N/A	COMPLETED
19-027290	Completed	T/OFF DELINQUENT	1/19/2018	12:00 AM	1/19/2018
19-027290		T/OFF DELINQUENT	1/18/2018	1/19/2018	COMPLETED

Special Billing Receipt: BLIGHT GRASS

Department of Property Maintenance-Account No:

Parcel # 1333428023

Name ADAMS JEFFERY P & MOREHART M

Address 7551 PROSPECT
WARREN MI 48091

Invoice No 17193 Invoice Date 09/09/19

Invoice Amount 350.00 Service Date 08/29/19

Special Billing Receipt: BLIGHT GRASS

Department of Property Maintenance-Account No:

Parcel # 1333428023

Name ADAMS JEFFERY P & MOREHART M

Address 7551 PROSPECT
WARREN MI 48091

Invoice No 17474 Invoice Date 06/10/20

Special Billing Receipt: BLIGHT GRASS

Department of Property Maintenance-Account No:

Parcel # 1333428023

Name ADAMS JEFFERY P & MOREHART M

Address 7551 PROSPECT
WARREN MI 48091

Invoice No 17468 Invoice Date 06/10/20

Invoice Amount 162.50 Service Date 05/12/20

Weed Billing Receipt

Department of Property Maintenance--Account No 101-000-3698

Parcel # 1333428023

Name ADAMS JEFFERY P & MOREHART M

Address 7551 PROSPECT
WARREN MI 48091

Invoice No 47150 Invoice Date 05/18/23

Invoice Amount 106.25 Date Cut 05/10/23

Weed Billing Receipt

Department of Property Maintenance--Account No 101-000-3698

Parcel # 1333428023

Name ADAMS JEFFERY P & MOREHART M

Address 7551 PROSPECT
WARREN MI 48091

Invoice No 47073 Invoice Date 01/12/23

Invoice Amount 106.25 Date Cut 09/30/22



DEPARTMENT OF PUBLIC SERVICE

ONE CITY SQUARE, SUITE 320
WARREN, MI 48093-5284
(586) 574-4604
FAX (586) 574-4517
www.cityofwarren.org

March 19, 2024

Council Secretary

RE: Resolution for 20800 Groesbeck (Demolition of a Commercial Building) Nuisance Abatement

Honorable Council Secretary:

The approval of a resolution is necessary for collection proceedings relating to the removal of a commercial building at 20800 Groesbeck which is under the nuisance abatement program.

Attached, please find the appropriate resolutions 1 and 2 and place on the **April 23, 2024 consent agenda** for a City Council Meeting **May 28, 2024** to review and confirm Special Assessment Roll No. 530 . Thank you for your cooperation in this matter.

Sincerely,

David Muzzarelli, Director
Department of Public Service

Read and Concur,

Approved:

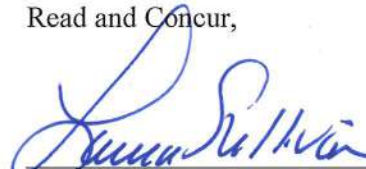
City Attorneys Office

Read and Concur,

Approved:

Lori M. Stone, Mayor

RDS/al
Building
Treasurer
Controllers
City Clerk
Assessor

**1st SAR Nuisance Resolution
20800 Groesbeck (13-35-353-005)**

RESOLUTION

A _____ Meeting of the City Council of the City of Warren, County of Macomb, Michigan, held on _____, _____ at 7:00 p.m. Eastern Time in the Council Chamber of the Community Center, 5460 Arden, Warren, Michigan.

PRESENT: Councilmember: _____

ABSENT: Councilmember: _____

The following preamble and resolution were offered by Councilmember _____ and supported by Councilmember _____:

The City Council held a public appeal hearing on the Hearing Officer's nuisance determination, and adopted a resolution upholding the Hearing Officer's determination that a nuisance existed upon the following described Property ("Property"):

A parcel of land being a part of the SW ¼ of Section 35, Town 1 North, Range 12 East, City of Warren, Macomb County, Michigan described as follows: Commencing at the intersection of the North side line of 8 Mile Road and Southeast side line of Groesbeck Hwy. (M-97); thence East 487.70 feet, thence along the West line of "Frank G. Nall's Sunset Hills Sub." North 0 degrees 30 minutes East 483.44 to the point of beginning; thence South 89 degrees 49 minutes 30 seconds West 205.35 feet; thence along the Southeast side line of Groesbeck Hwy. (120 feet wide) North 30 degrees 40 minutes 30 seconds East 410.07 feet; thence along the West line of Frank G. Nall's Sunset Hills Subdivision, South 0 degrees 37 minutes 30 seconds West 352.12 feet to the point of beginning.

And

Part of the Southwest ¼ of Section 35, Town 1 North, Range 12 East, City of Warren, Macomb County, Michigan being more particularly described as follows: Beginning at a point which is due East 487.70 feet along the North line of Eight Mile Road; and North 00 degrees 30 minutes 00 seconds East 357.00 feet; along the West line of Frank G. Nall's Sun Set Hill Subdivision according to the plat thereof as recorded in Liber 3, Page 151 of Plats, Macomb County Records from the intersection of the North line of Eight Mile Road and Southeasterly line of Groesbeck Highway; thence due West 279.06 feet; thence along the Southeasterly line of Groesbeck Highway (120 feet wide) North 30 degrees 40 minutes 30 seconds East 147.00 feet; thence due East 205.17 feet; thence along the West line of said Frank G. Nall's Sun Set Hill Subdivision South 00 degrees 30 minutes 00 seconds West 126.44 feet to the point of beginning.

T1N, R12E SEC 35 COMM AT INTER-SECTION N LINE OF 8 MILE RD & S'LY SIDELINE OF GROESBECK HWY M-97; THE 487.7 FT; THE NO*30'E 357.0 FT; THE W 279.06 FT; THE N 30*40' 30" E 545.0 FT; THE SO*30W 478.0 FT ALG W LINE OF FRANK G NALLS SUNSET HILLS SUB TO POB.

**Owner(s) Burger King Company LLC
Burger King Corporation #728
The Corporation Company
Fifth Kendall Realty Corp
Girard Trust Bank**

The City Council ordered abatement of the nuisance within **21 days** of the public appeal hearing and if the nuisance was not abated within the time limit, the City Council directed the Director of Public Service to direct the removal of the nuisance. The City Clerk has notified the Property owner(s) of the City Council Resolution, and order of nuisance removal.

The Property owner(s) failed to remove the nuisance within the time period prescribed by City Council.

The Director of Public Service obtained removal of the nuisance by demolition pursuant to the Resolution of City Council.

The Director of Public Service has filed this report of the work done and the expenses incurred in the abatement of the nuisance.

NOW, THEREFORE, IT IS RESOLVED, that the City Council does hereby determine that the following charges shall be levied as a special assessment against the Property indicated:

<u>PROPERTY</u>	<u>CHARGES</u>
Parcel No. 13-35-353-005 also known as 20800 Groesbeck	\$26,359.50

IT IS FURTHER RESOLVED, that the City Assessor is hereby instructed to prepare a special assessment roll in accordance with the above determination and designate the name by which the roll shall be known.

IT IS FURTHER RESOLVED, that the special assessment roll shall be divided into ten (10) annual installments, and that the deferred installments of the special assessment roll shall bear interest at the rate of 8 (8%) per cent per annum.

IT IS FURTHER RESOLVED, that the special assessment roll shall be certified by the City Assessor and filed with the City Clerk. The City Clerk shall give notice by certified mail to the owner(s) of the Property upon which the aforesaid charges are levied, stating the basis for the assessment, the amount thereof, and the property affected, and giving the Property owner(s) until the 28th day of May, 2024, for payment to be made. The notice shall further state that if payment is not made before the said 28th day of May, 2024, a public hearing shall be held on the aforesaid date before the City Council in the Council Chamber of the Community Center, 5460 Arden, Warren, Michigan 48092 at 7:00 p.m., for the purpose of hearing any objections to said special assessment roll as prepared.

AYES: Councilmember: _____

NAYS: Councilmember: _____

RESOLUTION DECLARED ADOPTED this _____ day of _____, _____.

MINDY MOORE
Council Secretary

CERTIFICATION

STATE OF MICHIGAN)
)SS.
COUNTY OF MACOMB)

I, SONJA BUFFA, duly elected City Clerk for the City of Warren, Macomb County, Michigan, hereby certify that the foregoing is a true and correct copy of the resolution adopted by the Council of the City of Warren at its meeting held on

_____.

SONJA BUFFA
City Clerk

**2nd SAR Nuisance Resolution
20800 Groesbeck (13-35-353-005)**

RESOLUTION

A _____ Meeting of the City Council of the City of Warren, County of Macomb, Michigan, held on _____, _____, at 7:00 p.m. Eastern _____ Time, in the Council Chamber of the Community Center, 5460 Arden, Warren, Michigan.

PRESENT: Councilmember: _____

ABSENT: Councilmember: _____

The following preamble and resolution were offered by Councilmember _____ and supported by Councilmember _____:

By resolution adopted _____, the City Council determined to levy a special assessment against the following described Property;

Parcel No. (13-35-353-005) also known as 20800 Groesbeck

The City Assessor has prepared a special assessment roll to Levy a special assessment against the Property indicated:

PROPERTY

CHARGES

Parcel No. 13-35-353-005 also known as 20800 Groesbeck

\$26,359.50

A parcel of land being a part of the SW ¼ of Section 35, Town 1 North, Range 12 East, City of Warren, Macomb County, Michigan described as follows: Commencing at the intersection of the North side line of 8 Mile Road and Southeast side line of Groesbeck Hwy. (M-97); thence East 487.70 feet, thence along the West line of "Frank G. Nall's Sunset Hills Sub." North 0 degrees 30 minutes East 483.44 to the point of beginning; thence South 89 degrees 49 minutes 30 seconds West 205.35 feet; thence along the Southeast side line of Groesbeck Hwy. (120 feet wide) North 30 degrees 40 minutes 30 seconds East 410.07 feet; thence along the West line of Frank G. Nall's Sunset Hills Subdivision, South 0 degrees 37 minutes 30 seconds West 352.12 feet to the point of beginning.

And

Part of the Southwest ¼ of Section 35, Town 1 North, Range 12 East, City of Warren, Macomb County, Michigan being more particularly described as follows: Beginning at a point which is due East 487.70 feet along the North line of Eight Mile Road; and North 00 degrees 30 minutes 00 seconds East 357.00 feet; along the West line of Frank G. Nall's Sun Set Hill Subdivision according to the plat thereof as recorded in Liber 3, Page 151 of Plats, Macomb County Records from the intersection of the North line of Eight Mile Road and Southeasterly line of Groesbeck Highway; thence due West 279.06 feet; thence along the Southeasterly line of Groesbeck Highway (120 feet wide) North 30 degrees 40 minutes 30 seconds East 147.00 feet; thence due East 205.17 feet; thence along the West line of said Frank G. Nall's Sun Set Hill Subdivision South 00 degrees 30 minutes 00 seconds West 126.44 feet to the point of beginning.

T1N, R12E SEC 35 COMM AT INTER-SECTION N LINE OF 8 MILE RD & S'LY SIDELINE OF GROESBECK HWY M-97; THE 487.7 FT; THE NO*30'E 357.0 FT; THE W 279.06 FT; THE N 30*40' 30" E 545.0 FT; THE SO*30W 478.0 FT ALG W LINE OF FRANK G NALLS SUNSET HILLS SUB TO POB.

**Owner(s) Burger King Company LLC
Burger King Corporation #728
The Corporation Company
Fifth Kendall Realty Corp
Girard Trust Bank**

The special assessment roll has been certified by the City Assessor and filed with the City Clerk;

The City Clerk has given notice by certified mail on _____ to the owners of the Property upon which the aforesaid charges are levied, stating the basis for the assessment, the amount thereof, and the Property affected, and giving the property owners until the 28th day of May, 2024, for payment to be made;

Payment has not been made, and a public hearing having been held on May 28th, 2024, after notice of the hearing having been given to the Property owners, in the notice described above;

NOW, THEREFORE, IT IS RESOLVED, that the special assessment roll in the following amount and bearing the following roll number is hereby confirmed as presented by the City Assessor:

SPECIAL ASSESSMENT NO. 530 - \$26,359.50

IT IS FURTHER RESOLVED, that the special assessment roll shall be divided into ten (10) annual installments, the first installment(s) shall be due on July 1, 2025, and the subsequent installment(s) shall be due on July 1 of each and every year thereafter, bearing interest at the rate of eight (8%) per cent per annum, commencing on August 1, 2025.

IT IS FURTHER RESOLVED, that the installments of the special assessment roll shall be collected in the manner required by the appropriate provisions of Chapter 33, of the Code of Ordinances of the City of Warren.

AYES: Councilmember: _____

NAYS: Councilmember: _____

RESOLUTION DECLARED ADOPTED this _____ day of _____, _____.

MINDY MOORE
Council Secretary

CERTIFICATION

STATE OF MICHIGAN)
)SS.
COUNTY OF MACOMB)

I, SONJA BUFFA, duly elected City Clerk for the City of Warren, Macomb County, Michigan, hereby certify that the foregoing is a true and correct copy of the resolution adopted by the Council of the City of Warren at its meeting held on _____, _____.

SONJA BUFFA
City Clerk



April 2, 2024

DEPARTMENT OF PUBLIC SERVICE
ONE CITY SQUARE, SUITE 320
WARREN, MI 48093-5284
(586) 574-4604
FAX (586) 574-4517
www.cityofwarren.org

Council Secretary

RE: Resolution for 8081 Hupp (Demolition of a House and Shed) Nuisance Abatement

Honorable Council Secretary:

The approval of a resolution is necessary for collection proceedings relating to the removal of a house and shed at 8081 Hupp which is under the nuisance abatement program.

Attached, please find the appropriate resolutions 1 and 2 and place on the April 23, 2024 consent agenda for a City Council Meeting May 28, 2024 to review and confirm Special Assessment Roll No. 531 .
Thank you for your cooperation in this matter.

Sincerely,

David Muzzarelli, Director
Department of Public Service

Read and Concur,

Approved:

City Attorneys Office

Read and Concur,

Approved:

Lori M. Stone, Mayor

RDS/al
Building
Treasurer
Controllers
City Clerk
Assessor



RECEIVED

APR 03 2024

DEPARTMENT OF PUBLIC SERVICE

ONE CITY SQUARE, SUITE 320

WARREN, MI 48093-5284

(586) 574-4604

FAX (586) 574-4517

www.cityofwarren.org

CITY ATTORNEY'S OFFICE

April 2, 2024

City Attorney,

Fire damaged home (908 square ft.) 1 ¼ story house with crawl space, shed 8 ft. x 8 ft. with slab at:

8081 Hupp
13-34-105-021

The East 20 feet of Lot 190 and the West 20 feet of Lot 191-Pipers First Van Dyke Farms, as recorded in Liber 3, Page 93 of Plats, Macomb County Records.

Interested Parties: Debra J Seid
Macomb County Treasurer

Please be advised that the nuisance at the above-noted location has been completed through efforts of the City as directed by the Nuisance Abatement Board of Appeals. Please institute collection proceedings including but not limited to any civil action which may be available.

Cost incurred by the City in effecting the abatement of this nuisance is as follows:

Demolition Bid # RFQ-W-PS316	\$ 8,000.00
Asbestos Survey	\$ 386.00
City Administrative Fees	\$ 1,092.50
Total	\$ 9,478.50

It is recommended these cost be charged to the property owner under proposed Special Assessment Roll No. 531. A Certificate of Abatement will be issued at a later date.

Sincerely,

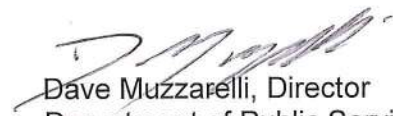
Dave Muzzarelli, Director
Department of Public Service

- cc: Mayor
- Division of Building
- Property Maintenance
- City Controller
- City Clerk
- City Assessor
- Treasurer

**1st SAR Nuisance Resolution
8081 Hupp (13-34-105-021)**

RESOLUTION

A _____ Meeting of the City Council of the City of Warren, County of Macomb, Michigan, held on _____, _____ at 7:00 p.m. Eastern Time in the Council Chamber of the Community Center, 5460 Arden, Warren, Michigan.

PRESENT: Councilmember: _____

ABSENT: Councilmember: _____

The following preamble and resolution were offered by Councilmember _____ and supported by Councilmember _____
_____:

The City Council held a public appeal hearing on the Hearing Officer's nuisance determination, and adopted a resolution upholding the Hearing Officer's determination that a nuisance existed upon the following described Property ("Property"):

THE EAST 20 feet of lot 190 and the West 20 feet of Lot 191-Pipers First Van Dyke Farms as recorded in Liber 3, Page 93 of Plats Macomb County Records.

**Owner(s) Debra J. Seid
Macomb County Treasurer**

The City Council ordered abatement of the nuisance within **21 days** of the public appeal hearing and if the nuisance was not abated within the time limit, the City Council directed the Director of Public Service to direct the removal of the nuisance. The City Clerk has notified the Property owner(s) of the City Council Resolution, and order of nuisance removal.

The Property owner(s) failed to remove the nuisance within the time period prescribed by City Council.

The Director of Public Service obtained removal of the nuisance by demolition pursuant to the Resolution of City Council.

The Director of Public Service has filed this report of the work done and the expenses incurred in the abatement of the nuisance.

NOW, THEREFORE, IT IS RESOLVED, that the City Council does hereby determine that the following charges shall be levied as a special assessment against the Property indicated:

<u>PROPERTY</u>	<u>CHARGES</u>
Parcel No. 13-34-105-021 also known as 8081 Hupp	\$9,478.50

IT IS FURTHER RESOLVED, that the City Assessor is hereby instructed to prepare a special assessment roll in accordance with the above determination and designate the name by which the roll shall be known.

IT IS FURTHER RESOLVED, that the special assessment roll shall be divided into ten (10) annual installments, and that the deferred installments of the special assessment roll shall bear interest at the rate of 8 (8%) per cent per annum.

IT IS FURTHER RESOLVED, that the special assessment roll shall be certified by the City Assessor and filed with the City Clerk. The City Clerk shall give notice by certified mail to the owner(s) of the Property upon which the aforesaid charges are levied, stating the basis for the assessment, the amount thereof, and the property affected, and giving the Property owner(s) until the 28th day of May, 2024, for payment to be made. The notice shall further state that if payment is not made before the said 28th day of May, 2024, a public hearing shall be held on the aforesaid date before the City Council in the Council Chamber of the Community Center, 5460 Arden, Warren, Michigan 48092 at 7:00 p.m., for the purpose of hearing any objections to said special assessment roll as prepared.

AYES: Councilmember: _____

NAYS: Councilmember: _____

RESOLUTION DECLARED ADOPTED this _____ day of _____, _____.

MINDY MOORE
Council Secretary

CERTIFICATION

STATE OF MICHIGAN)
)SS.
COUNTY OF MACOMB)

I, SONJA BUFFA, duly elected City Clerk for the City of Warren, Macomb County, Michigan, hereby certify that the foregoing is a true and correct copy of the resolution adopted by the Council of the City of Warren at its meeting held on _____, _____.

SONJA BUFFA
City Clerk

**2nd SAR Nuisance Resolution
8081 Hupp (13-34-105-021)**

RESOLUTION

A _____ Meeting of the City Council of the City of Warren, County of Macomb, Michigan, held on _____, _____, at 7:00 p.m. Eastern _____ Time, in the Council Chamber of the Community Center, 5460 Arden, Warren, Michigan.

PRESENT: Councilmember: _____

ABSENT: Councilmember: _____

The following preamble and resolution were offered by Councilmember _____ and supported by Councilmember _____:

By resolution adopted _____, the City Council determined to levy a special assessment against the following described Property;

Parcel No. (13-34-105-021) also known as 8081 Hupp

The City Assessor has prepared a special assessment roll to Levy a special assessment against the Property indicated:

PROPERTY

CHARGES

Parcel No. 13-34-105-021 also known as 8081 Hupp

\$9,478.50

The East 20 feet of Lot 190 and the West 20 feet of Lot 191-PIPERS FIRST VAN DYKE FARMS, as recorded in Liber 3, Page 93 of Plats, Macomb County Records.

**Owner(s) Debra J Seid
Macomb County Treasurer**

The special assessment roll has been certified by the City Assessor and filed with the City Clerk;

The City Clerk has given notice by certified mail on _____ to the owners of the Property upon which the aforesaid charges are levied, stating the basis for the assessment, the amount thereof, and the Property affected, and giving the property owners until the 28th day of May, 2024, for payment to be made;

Payment has not been made, and a public hearing having been held on May 28, 2024, after notice of the hearing having been given to the Property owners, in the notice described above;

NOW, THEREFORE, IT IS RESOLVED, that the special assessment roll in the following amount and bearing the following roll number is hereby confirmed as presented by the City Assessor:

SPECIAL ASSESSMENT NO. 531 - \$9,478.50

IT IS FURTHER RESOLVED, that the special assessment roll shall be divided into ten (10) annual installments, the first installment(s) shall be due on July 1, 2025, and the subsequent installment(s) shall be due on July 1 of each and every year thereafter, bearing interest at the rate of eight (8%) per cent per annum, commencing on August 1, 2025.



April 12, 2024

PLANNING DEPARTMENT

ONE CITY SQUARE, SUITE 315

WARREN, MI 48093-5283

(586) 574-4687

FAX (586) 574-4645

www.cityofwarren.org

TO: Lori M. Stone, Mayor

FROM: Ronald F. Wuerth, Planning Director

RE: SUBDIVISION LOT SPLIT; located on the southeast corner of Twelve Mile Road and Adler Drive; 12980 Twelve Mile Road; Section 14; Osama Razooq (Warren C. Avey/Urban Land Consultants); PSLS230003.

At a public hearing on March 25, 2024, the Planning Commission adopted a resolution pertaining to the above-captioned matter. The resolution, as adopted, is a recommendation to the City Council to APPROVE the above-described subdivision lot split.

You will find attached herewith a copy of the staff findings and recommendation, resolution, map, petitioner's letter, minutes and plans in connection with this matter.

Should you and/or your staff wish to discuss the details of this project or to go over any of the items in this packet, myself and the Planning staff are available for assistance.

Sincerely,

A handwritten signature in blue ink that reads "Ronald F. Wuerth".

Ronald F. Wuerth, AICP
Planning Director

/mzm

Attachments



April 12, 2024

PLANNING DEPARTMENT

ONE CITY SQUARE, SUITE 315
WARREN, MI 48093-5283
(586) 574-4687
FAX (586) 574-4645
www.cityofwarren.org

TO: Mindy Moore, Secretary
Warren City Council

FROM: Mayor, Planning Commission and Planning Director

RE: SUBDIVISION LOT SPLIT; located on the southeast corner of Twelve Mile Road and Adler Drive; 12980 Twelve Mile Road; Section 14; Osama Razooq (Warren C. Avey/Urban Land Consultants); PSLS230003.

At a public hearing on March 25, 2024, the Planning Commission adopted a resolution pertaining to the above-captioned matter. The resolution, as adopted, is a recommendation to the City Council to APPROVE the above-described subdivision lot split.

You will find attached herewith a copy of the staff findings and recommendation, resolution, map, petitioner's letter, minutes and plans in connection with this matter.

Please schedule this matter for formal action by the City Council. If you have any questions or need additional information, please contact the Planning Director, Ronald Wuerth.

Thank you for your cooperation in this matter.

Respectfully submitted,

Read and Concur:

A handwritten signature in black ink, appearing to read "Mahmuda Mouri", written over a horizontal line.

Mahmuda Mouri
Commission Secretary

A handwritten signature in black ink, appearing to read "Louis M. Stas", written over a horizontal line.

Mayor

/mzm

Attachments

**RESOLUTION FOR SUBDIVISION LOT SPLIT OF PROPERTY LOCATED ON THE
SOUTHEAST CORNER OF TWELVE MILE ROAD AND ADLER DRIVE
12980 TWELVE MILE ROAD**

A regular meeting of the City Council of the City of Warren, Macomb County, Michigan held on _____, 2024, at 7 p.m. Eastern Daylight Savings Time in at the Warren Community Center, Warren, Michigan.

PRESENT: _____

ABSENT: _____

The following preamble and resolution was offered by Councilmember

_____ and supported by Councilmember _____:

WHEREAS, Osama Razooq, petitioner for the property located on the southeast corner of Twelve Mile Road and Adler Drive, has petitioned the Planning Commission of the City of Warren requesting that Outlot A of Royal Gardens Subdivision be split from one lot into three lots; currently described as:

Outlot A, "Royal Gardens Subdivision", part of the Northeast 1/4 of Section 14, T.1N., R.12E., City of Warren, Macomb County, Michigan according to the record plat as recorded in Liber 43 of plats on page 13 of the Macomb County Records.

The proposed reconfigured parcels are described as follows:

- a) Parcel "A" would be the west 60.09 ft. of the parent parcel, Outlot A, being rectangular in shape measuring 60.09 ft. x 135.16 ft. and containing 8,122 sq. ft. This parcel is undeveloped and contains a lawn. The plan indicates that this parcel is proposed to be constructed with a 2-story single family home with a driveway to Adler Dr.

- b) Parcel "B" would be the east 65.00 ft. of the west 125.09 ft. of Outlot A, being rectangular in shape measuring 65.00 ft. x 135.16 ft. and containing 8,785 sq. ft. This parcel contains the existing residential dwelling (built in approximately 1945 according to Assessing records), lawn area, and asphalt parking area.
- c) Parcel "C" would be the east 60.00 ft. of Outlot A, being rectangular in shape measuring 60 ft. x 135.16 ft. and containing 8,110 sq. ft. This parcel contains asphalt that formally supported an office parking lot, and lawn area.

AND WHEREAS, the City of Warren, a municipal corporation pursuant to Granted under Act No. 288 of the Public Acts of 1967 (the Subdivision Control Act of 1967) as amended by the Land Division Act P. A. 591 of 1996, provides that no lot, outlot, or other parcel of land in a recorded plat shall be further partitioned or divided unless in conformity with the ordinances of the municipality;

AND WHEREAS, the Planning Commission of the City of Warren has held a hearing thereon Monday the 25th day of March, 2024, at the City of Warren, Michigan, and has considered the request of Osama Razooq, requesting that Outlot A of Royal Gardens Subdivision be split from one lot into three lots of the above-described property and has considered the objections raised thereto:

NOW THEREFORE, BE IT RESOLVED, that the Planning Commission of the City of Warren does hereby recommend to the Council of the City of Warren the lot split of the above-described property and has, as aforesaid, be approved provided:

It is recommended that the lot split be APPROVED subject to the standard conditions of the Planning Commission and more specifically:

1. The lots and abutting streets shall be graded and drained. The petitioner must send a letter to the Public Service Director requesting an inspection of the site. The Director, in turn, forwards the request to the Engineering Division to perform the inspection. A copy of the positive results of the inspection shall be provided to the Planning Department.

2. The utility companies be given the opportunity to obtain any easements they may require.
3. Approval of City Council shall be obtained. City Council approval shall become effective upon compliance with all conditions listed. The petitioner shall complete the conditions within one (1) year.
4. The petitioner must provide the Planning Department with documentation indicating that all conditions as assigned are completed. The department then notifies the City Clerk that a certified copy of the resolution shall be recorded with the Macomb County Register of Deeds.

AYES: _____

NAYS: _____

RESOLUTION DECLARED ADOPTED this _____ day of _____, 2024.

MINDY MOORE
Secretary of the Council

RESOLUTION

WHEREAS, Osama Razooq, petitioner for the property located on the southeast corner of Twelve Mile Road and Adler Drive, has petitioned the Planning Commission of the City of Warren requesting that Outlot A of Royal Gardens Subdivision be split from one lot into three lots; currently described as:

Outlot A, "Royal Gardens Subdivision", part of the Northeast 1/4 of Section 14, T.1N., R.12E., City of Warren, Macomb County, Michigan according to the record plat as recorded in Liber 43 of plats on page 13 of the Macomb County Records.

The proposed reconfigured parcels are described as follows:

- a) Parcel "A" would be the west 60.09 ft. of the parent parcel, Outlot A, being rectangular in shape measuring 60.09 ft. x 135.16 ft. and containing 8,122 sq. ft. This parcel is undeveloped and contains a lawn. The plan indicates that this parcel is proposed to be constructed with a 2-story single family home with a driveway to Adler Dr.
- b) Parcel "B" would be the east 65.00 ft. of the west 125.09 ft. of Outlot A, being rectangular in shape measuring 65.00 ft. x 135.16 ft. and containing 8,785 sq. ft. This parcel contains the existing residential dwelling (built in approximately 1945 according to Assessing records), lawn area, and asphalt parking area.
- c) Parcel "C" would be the east 60.00 ft. of Outlot A, being rectangular in shape measuring 60 ft. x 135.16 ft. and containing 8,110 sq. ft. This parcel contains asphalt that formally supported an office parking lot, and lawn area.

AND WHEREAS, the City of Warren, a municipal corporation pursuant to Granted under Act No. 288 of the Public Acts of 1967 (the Subdivision Control Act of 1967) as amended by the Land Division Act P. A. 591 of 1996, provides that no lot, outlot, or other parcel of land in a recorded plat shall be further partitioned or divided unless in conformity with the ordinances of the municipality;

AND WHEREAS, the Planning Commission of the City of Warren has held a hearing thereon Monday the 25th day of March, 2024, at the City of Warren, Michigan, and has considered the request of Osama Razooq, requesting that Outlot A of Royal Gardens Subdivision be split from one lot into three lots of the above-described property and has considered the objections raised thereto:

NOW THEREFORE, BE IT RESOLVED, that the Planning Commission of the City of Warren does hereby recommend to the Council of the City of Warren the lot split of the above-described property and has, as aforesaid, be approved provided:

It is recommended that the lot split be APPROVED subject to the standard conditions of the Planning Commission and more specifically:

1. The lots and abutting streets shall be graded and drained. The petitioner must send a letter to the Public Service Director requesting an inspection of the site. The Director, in turn, forwards the request to the Engineering Division to perform the inspection. A copy of the positive results of the inspection shall be provided to the Planning Department.
2. The utility companies be given the opportunity to obtain any easements they may require.
3. Approval of City Council shall be obtained. City Council approval shall become effective upon compliance with all conditions listed. The petitioner shall complete the conditions within one (1) year.
4. The petitioner must provide the Planning Department with documentation indicating that all conditions as assigned are completed. The department then notifies the City Clerk that a certified copy of the resolution shall be recorded with the Macomb County Register of Deeds.

RESOLUTION adopted at the meeting of March 25, 2024.

PLANNING COMMISSION OF THE CITY OF WARREN



Warren Smith, Chair

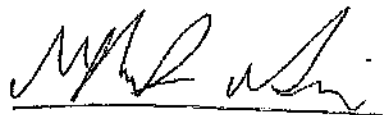

Mahmuda Mouri, Secretary



PLANNING DEPARTMENT

ONE CITY SQUARE, SUITE 315

WARREN, MI 48093-5283

(586) 574-4687

Fax (586) 574-4645

www.cityofwarren.org

March 27, 2024

Osama Razooq
8755 Crestview Dr.
Sterling Heights, MI 48312

RE: SUBDIVISION LOT SPLIT (REVISED PLAN); located on the southeast corner of Twelve Mile Road and Adler Drive; 12980 Twelve Mile Road; Section 14; Osama Razooq (Warren C. Avey/Urban Land Consultants); PSLs230003. **Recommended for approval by the Planning Commission on September 11, 2023. The petitioner submitted an updated survey for a new configuration of the proposed subdivision lot split.**

Dear Osama Razooq:

At its meeting of March 25, 2024, the City of Warren Planning Commission voted to **APPROVE CONDITIONALLY** the above-described lot split, subject to the standard conditions of the Planning Commission and more specifically:

1. The lots and abutting streets shall be graded and drained. The petitioner must send a letter to the Public Service Director requesting an inspection of the site. The Director, in turn, forwards the request to the Engineering Division to perform the inspection. A copy of the positive results of the inspection shall be provided to the Planning Department.
2. The utility companies be given the opportunity to obtain any easements they may require.
3. Approval of City Council shall be obtained. City Council approval shall become effective upon compliance with all conditions listed. The petitioner shall complete the conditions within one (1) year.
4. The petitioner must provide the Planning Department with documentation indicating that all conditions as assigned are completed. The department then notifies the City Clerk that a certified copy of the resolution shall be recorded with the Macomb County Register of Deeds.

And furthermore recommendations were received from the following division and departments to notify the petitioner that these items will be addressed during the Building Division permit process:

TAXES: Current.

ENGINEERING: Preliminary review of this site yielded no comments from the Engineering Division.

AT&T: AT&T does not object to this parcel split.

MCPW: Please be advised that this letter is for comment in relation to right of way and County drain easements only. It appears there will be no work within or near a County drain or easement, therefore this office would have no objection to this request. Prior to site plan approval, any proposed project that is under the jurisdiction of this office shall apply the Macomb County Public Works Office design standards. It is advisable to schedule an engineering meeting with this office to discuss how our standards may apply.

Should you have any questions, please do not hesitate to contact our office at 586-574-4687.

Sincerely,

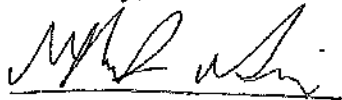

Mahmuda Mouri
Commission Secretary

/mzm

cc: Mayor
Ronald F. Wuerth, Planning Director
Mary Michaels, Chief Assistant City Attorney
Everett Murphy, Chief Zoning Inspector
James Kazanowski, Fire Department
Warren C. Avey, Urban Land Consultants
Corey Vought, Urban Land Consultants

- 8) SUBDIVISION LOT SPLIT: ONE LOT INTO THREE LOTS (REVISED PLAN)
12980 TWELVE MILE
Process #PSLS230003
Section 14
Osama Razooq (Warren C. Avey/Urban Land Consultants)
March 25, 2024
Page 1

FINDINGS

1. The petitioner is requesting that Outlot A of Royal Gardens Subdivision be split from one lot into three lots. The property in question is located on the southeast corner of Twelve Mile Rd. and Adler Dr.

The purpose of the lot split is to create three residential lots. The existing home (former office) in the center would be retained, and two (2) new residential dwellings would be constructed on the undeveloped proposed lots A and C. According to Assessing records the existing home was constructed in approximately 1945.

The petitioner submitted an updated survey for a new configuration of the proposed subdivision lot split. The reason for the updated survey and new configuration for the subdivision lot split is due to the denial from the Zoning Board of Appeals on December 13, 2023. The updated survey meets the standards of the Zoning Ordinance, and can therefore be forwarded to the City Council if conditionally approved by the Planning Commission.

2. **CHARACTERISTICS OF THE PROPERTY IN QUESTION CAN BE SUMMARIZED AS FOLLOWS:**

- a) **SIZE AND DIMENSIONS OF PROPERTY:** A rectangular shaped parcel measuring 135 ft. x 185 ft. and containing 24,975 sq. ft. with 185 ft. of frontage along Twelve Mile Rd. and 135 ft. of frontage along Alder Dr. of Outlot A of Royal Gardens Subdivision.
- b) **PRESENT USE:** Single Family Dwelling/Former Thompson Dental Laboratory
- c) **PRESENT ZONING:** PB, Professional Business District

The PB District has existed since the adoption of the Zoning Ordinance on July 21, 1960.

3. **CURRENT STATUS OF APPLICATION**

- a) Chapter 35 Subdivision regulation, Article II Platting procedure and data required; Section 35-26 Lot splits of the Code of Ordinances require the Planning Commission to review proposed lot split(s) for the purpose of lot division within the subdivision plat, to review for conformance with all ordinances, administrative rules, regulations, and the master plan for the City and to make recommendations to the Board of Appeals, if necessary, and the City Council.

8) SUBDIVISION LOT SPLIT: ONE LOT INTO THREE LOTS (REVISED PLAN)
12980 TWELVE MILE
Process #PSLS230003
Section 14
Osama Razooq (Warren C. Avey/Urban Land Consultants)
March 25, 2024
Page 2

- b) On February 12, 2024, the petitioner met with Planning and Zoning staff to discuss the next steps for the lot split after the ZBA denial. A reconfiguration of the proposed lot split that would avoid the need for variances was discussed.
- c) On December 13, 2023, the Zoning Board of Appeals GRANTED the petitioner permission to retain an existing dwelling setback no less than 16 ft. from the front property line.
- d) On December 13, 2023, the Zoning Board of Appeals DENIED the petitioner permission to Split an existing parcel of land into 3 parcels with parcels "B" and "C" being 55 ft. wide.
- e) On September 11, 2023, the Planning Commission voted to APPROVE CONDITIONALLY the subdivision lot split (one lot into three).
- f) On April 14, 1976, the Zoning Board of Appeals GRANTED the petitioner permission to erect a 13 sq. ft. sign, not to exceed 3 ft. in width and 5 ft. in height with leading edge of sign 5 ft. from the front property line.

NOTE: The sign advertised a law office use located in the building. The sign no longer exists.

- g) On October 2, 1975, the Building Division issued Building Permit No. 93993 to convert dwelling into an office building (first floor remodel only).
- h) On March 17, 1975, the Planning Commission APPROVED the site plan for office building.
- i) On February 11, 1975, the City Council REZONED the property in question measuring 185 ft. x 135 ft. and containing 24,975 sq. ft. from R-1-C to PB as amended by Zoning Map No. 30-479.
- j) On December 30, 1958, the Macomb County register of Deeds recorded the plat of Royal Gardens Subdivision in L.43 P.13-14.

The majority of the lots were platted with 55 ft. lot widths. The lot widths became legal non-conforming lot widths. The Zoning Ordinance adopted on July 21, 1960 created a new minimum lot width of 60 ft.

- 8) SUBDIVISION LOT SPLIT: ONE LOT INTO THREE LOTS (REVISED PLAN)
12980 TWELVE MILE
Process #PSLS230003
Section 14
Osama Razooq (Warren C. Avey/Urban Land Consultants)
March 25, 2024
Page 3

NOTE: The City of Warren was designated a City on October 27, 1956. The City, during this time was using the Warren Township Zoning Ordinance to regulate the development. Royal Gardens Subdivision was permitted at the time. The City of Warren Zoning Ordinance was adopted on July 21, 1960 and in the process residential lot widths became 60 ft. in width.

- k) Notice letters were sent to the local school district, all City of Warren departments and divisions and affected utilities.

There were no objections, written and/or stated, to the lot split providing the following conditions are complied with:

- 1) From Macomb County Public Works (MCPW): Please be advised that this letter is for comment in relation to right of way and county drain easements only. It appears there will be no work within or near a county drain or easement, therefore this office would have no objection to this request. Prior to site plan approval, any proposed project that is under the jurisdiction of this office shall apply the Macomb County Public Works office design standards. It is advisable to schedule an engineering meeting with this office to discuss how our standards may apply.

4. GENERAL DESCRIPTION OF THE SURROUNDING PROPERTIES IS AS FOLLOWS:

The properties to the north, east, south and west are zoned R-1-C and contain single family dwellings.

5. THE SURVEY PLAN SUBMITTED BY THE PETITIONER INDICATES THAT:

- a) Parcel "A" would be the west 60.09 ft. of the parent parcel, Outlot A, being rectangular in shape measuring 60.09 ft. x 135.16 ft. and containing 8,122 sq. ft. This parcel is undeveloped and contains a lawn. The plan indicates that this parcel is proposed to be constructed with a 2-story single family home with a driveway to Adler Dr.
- b) Parcel "B" would be the east 65.00 ft. of the west 125.09 ft. of Outlot A, being rectangular in shape measuring 65.00 ft. x 135.16 ft. and containing 8,785 sq. ft. This parcel contains the existing residential dwelling (built in approximately 1945 according to Assessing records), lawn area, and asphalt parking area.
- c) Parcel "C" would be the east 60.00 ft. of Outlot A, being rectangular in shape measuring 60 ft. x 135.16 ft. and containing 8,110 sq. ft. This parcel contains asphalt that formally supported an office parking lot, and lawn area.

8) SUBDIVISION LOT SPLIT: ONE LOT INTO THREE LOTS (REVISED PLAN)
12980 TWELVE MILE
Process #PSLS230003
Section 14
Osama Razooq (Warren C. Avey/Urban Land Consultants)
March 25, 2024
Page 4

A note is provided on the plan indicating the asphalt parking lot will be removed for the construction of a new single family dwelling.

The concept plan indicates the buildable areas for the proposed residential dwellings, accessory structures, and driveways, etc. A key on the drawing shows the trees that will be removed. The petitioner will retain the mature trees located on parcels A, B, and C, except for those that will need to be removed for the construction of the new structures and driveways.

d) Parcels "A", "B" and "C" would meet the requirements of the Zoning Ordinance for lot width and area. The parcel is zoned PB, Professional business, but every one family dwelling shall comply with the requirement of VIII (R-1-P, One Family Residential and Parking District).

e) The following private/public utility easements are indicated on the plot plan:

A six (6) ft. private easement for public utilities is located along the south property line of the parcel.

6. CHARACTERISTICS OF THE EXISTING LOTS ARE AS FOLLOWS:

- a) The majority of the lots in Royal Gardens Subdivision were platted at 55 ft. in width, and that is how they have been developed. Outlot A was originally platted at 185 ft. x 135 ft.
- b) The existing dwellings are constructed primarily as ranch style dwellings with detached garages.

8) SUBDIVISION LOT SPLIT: ONE LOT INTO THREE LOTS (REVISED PLAN)
12980 TWELVE MILE
Process #PSLS230003
Section 14
Osama Razooq (Warren C. Avey/Urban Land Consultants)
March 25, 2024
Page 5

RECOMMENDATION

It is recommended that the lot split be APPROVED subject to the standard conditions of the Planning Commission and more specifically:

1. The lots and abutting streets shall be graded and drained. The petitioner must send a letter to the Public Service Director requesting an inspection of the site. The Director, in turn, forwards the request to the Engineering Division to perform the inspection. A copy of the positive results of the inspection shall be provided to the Planning Department.
2. The utility companies be given the opportunity to obtain any easements they may require.
3. Approval of City Council shall be obtained. City Council approval shall become effective upon compliance with all conditions listed. The petitioner shall complete the conditions within one (1) year.
4. The petitioner must provide the Planning Department with documentation indicating that all conditions as assigned are completed. The department then notifies the City Clerk that a certified copy of the resolution shall be recorded with the Macomb County Register of Deeds.

And furthermore recommendations were received from the following division and departments to notify the petitioner that these items will be addressed during the Building Division permit process:

TAXES: Current.

ENGINEERING: Preliminary review of this site yielded no comments from the Engineering Division.

AT&T: AT&T does not object to this parcel split.

MCPW: Please be advised that this letter is for comment in relation to right of way and County drain easements only. It appears there will be no work within or near a County drain or easement, therefore this office would have no objection to this request. Prior to site plan approval, any proposed project that is under the jurisdiction of this office shall apply the Macomb County Public Works Office design standards. It is advisable to schedule an engineering meeting with this office to discuss how our standards may apply.

SUBDIVISION LOT SPLIT; located on the southeast corner of Twelve Mile Road and Adler Drive; 12980 Twelve Mile Road; Section 14; Osama Razooq (Warren C. Avey/Urban Land Consultants). PSLs230003.

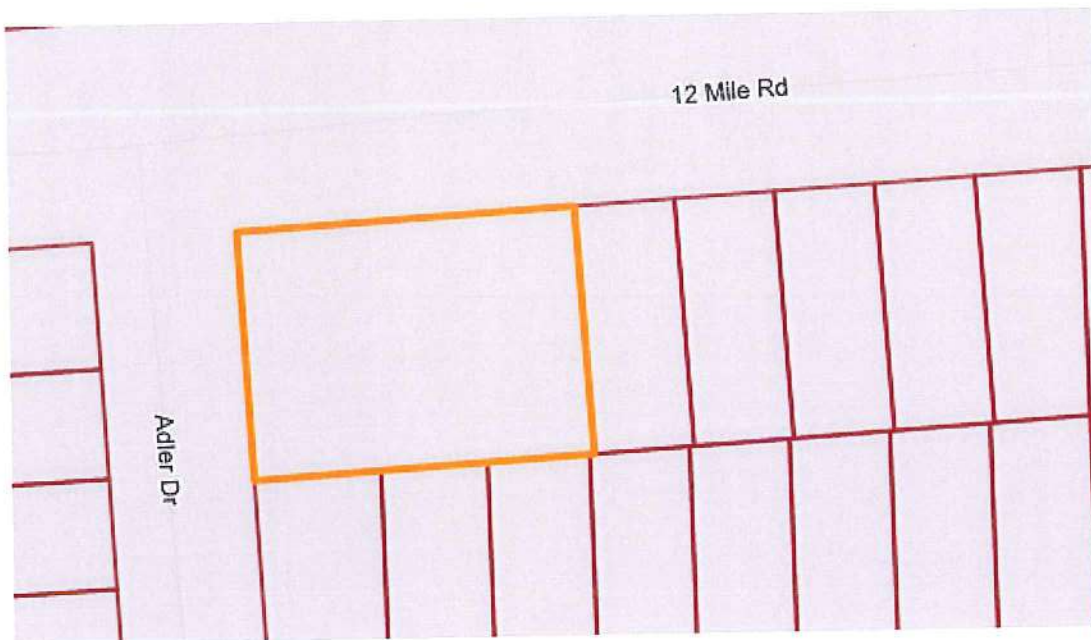

- C. SITE PLAN FOR PARKING LOT: Located on the east side of Amber Avenue, approximately 249.2 ft. south of Timken Avenue; 23364 Amber; Section 26; 2S Realty LLC (Martin Nicaj). **Approved on August 23rd, 2021. Never finished expired.**

MOTION:

A motion was made by Commissioner Tutt to recognize as an expired site plan, supported by Commissioner Robinson.

ROLL CALL:

The motion carried as follows:

Commissioner Tutt.....	Yes
Commissioner Robinson.....	Yes
Commissioner Ansar.....	Yes
Secretary Mouri.....	Yes
Vice Chair Boniecki.....	Yes
Chair Smith.....	Yes

- D. SITE PLAN FOR MOBILE MRI TRAILER PAD: Located on the east side of Hoover Road; approximately 260 ft. north of 13 Mile Road; Section 2; 31150 Hoover Road; Rajeev Jolly/Maxim MRI LLC (Dr. Narayan Verman/Hoover Real Estate): PSP210001. **Approved on March 22nd, 2021. Never finished expired.**

MOTION:

A motion was made by Commissioner Robinson to recognize as an expired site plan, supported by Commissioner Ansar.

ROLL CALL:

The motion carried as follows:

Commissioner Robinson.....	Yes
Commissioner Ansar.....	Yes
Commissioner Tutt.....	Yes
Secretary Mouri.....	Yes
Vice Chair Boniecki.....	Yes
Chair Smith.....	Yes

8. OLD BUSINESS:

SUBDIVISION LOT SPLIT (REVISED PLAN): Located on the southeast corner of Twelve Mile Road and Adler Drive; 12980 Twelve Mile Road; Section 14; Osama Razooq (Warren C. Avey/Urban Land Consultants); PSL230003. **Recommended for approval by the Planning Commission on September 11th, 2023. The petitioner submitted an**

updated survey for a new configuration of the proposed subdivision lot split.

PETITIONERS PORTION:

Mr. Osama Razooq – Good evening and thank you for having me here today again. We've revised the drawing regarding the three lot widths to be 60 x 65 x 60 you approved all the plans September 11, which was 75 x 55 x 55 and we revised it now for lot C.

Secretary Mouri reads the following correspondence:

TAXES: Current.

ENGINEERING: Preliminary review of this site yielded no comments from the Engineering Division.

AT&T: AT&T does not object to this parcel split.

MCPW: Please be advised that this letter is for comment in relation to right of way and county drain easements only. It appears there will be no work within or near a county drain or easement, therefore this office would have no objection to this request. Prior to site plan approval, any proposed project that is under the jurisdiction of this office shall apply the Macomb County Public Works Office design standards. It is advisable to schedule an engineering meeting with this office to discuss how our standards may apply.

Mr. Ron Wuerth reads the recommendation of the Staff:

MOTION:

A motion was made by Vice Chair Boniecki to approve, supported by Commissioner Ansar.

COMMISSIONERS PORTION:

Secretary Mouri – What's the reason for the change?

Mr. Osama Razooq – The original plan needed a variance and ZBA didn't approve it in December it need a variance so they didn't approve it.

Secretary Mouri – Okay thank you.

Commissioner Ansar – You had a chance to review all those recommendations?

Mr. Osama Razooq – Yes, I did.

Commissioner Ansar – Are you okay with them?

Mr. Osama Razooq – Yes.

Chair Smith – In parcel B the driveway comes out to Twelve Mile and it seems kind of close to the driveway coming in for parcel C. It's like a sharp turn there so I don't know if it would be better to widen the driveway or if you're using it as a dual driveway. It looks kind of strange like there might be some interference being close to the second driveway. Do you see how it's coming out and it's going to Twelve Mile where the other one is wide and is coming into parcel C, it just seems kind of awkward there.

Mr. Osama Razooq – Just off of Twelve Mile Road, the driveway just between the Twelve Mile Road and the front porch or the whole driveway?

Chair Smith – No just at the approach coming in.

Mr. Osama Razooq – Yes, that's fine we can make it wider.

Chair Smith – It just seems like it would be a little bit more convenient or designed a little bit different if we had easier access coming through there, what do you think?

Mr. Osama Razooq – Yes, I agree.

Chair Smith – I'd like to make that change then if it's possible. Mr. Wuerth, do you have something you'd like to say?

Mr. Ron Wuerth – I do, the driveway itself remember, it's the Road Commission's jurisdiction, it's their design of the roadway and the driveways that come out.

That driveway as I see it was designed by the surveyor not necessarily by the road authority, they will tell them how that should really look. I don't know about widening it but the flares that come out to the roadway may change to some degree but that's out of our purview, we don't have much of a right to dictate that.

Chair Smith – Thank you for that clarification.

ROLL CALL:

The motion carried as follows:

Vice Chair Boniecki.....	Yes
Commissioner Ansar.....	Yes
Commissioner Robinson.....	Yes
Commissioner Tutt.....	Yes
Secretary Mouri.....	Yes
Chair Smith.....	Yes



April 15, 2024

PLANNING DEPARTMENT

ONE CITY SQUARE, SUITE 315
WARREN, MI 48093-5283
(586) 574-4687
FAX (586) 574-4645
www.cityofwarren.org

TO: Lori M. Stone, Mayor

FROM: Ronald F. Wuerth, Planning Director

A handwritten signature in blue ink, appearing to read "RW", located to the right of the "FROM:" line.

RE: PROPOSED DRAFT FOR THE CITY OF WARREN VAN DYKE CORRIDOR PLAN; AN ADDENDUM TO THE CITY OF WARREN MASTER PLAN; A

comprehensive initiative for a rigorous three-year study encompassing resident and business surveys, as well as strategic engagements with key stakeholders, including City, County, and State officials. By February 2022, Beckett & Raeder, Inc. completed their preliminary study of the Van Dyke Corridor. This proposal is for a resolution to adopt and recommend to City Council and is an addendum to the 2021 City of Warren Master Plan; City of Warren; Tom Bommarito, DDA/TIFA Director (Beckett & Raeder, Inc., Planning Consultants).

At a public hearing on March 25, 2024, the Planning Commission adopted a resolution pertaining to the above-captioned matter. The resolution, as adopted, is a recommendation to the City Council to APPROVE the City of Warren Van Dyke Corridor Plan.

You will find attached herewith a copy of the staff findings and recommendation, resolution, petitioner's letter, minutes and proposed draft in connection with this matter. A link to the draft can be found on the Planning Department webpage.

Should you and/or your staff wish to discuss the details of this project or to go over any of the items in this packet, myself and the Planning staff are available for assistance.

Sincerely,

A large, handwritten signature in blue ink, clearly legible as "Ronald F. Wuerth", positioned above a horizontal line.

Ronald F. Wuerth, AICP
Planning Director

/mzm

Attachments

cc: Tom Bommarito, DDA/TIFA Director



April 15, 2024

TO: Mindy Moore, Secretary
Warren City Council

PLANNING DEPARTMENT

ONE CITY SQUARE, SUITE 315
WARREN, MI 48093-5283
(586) 574-4687
FAX (586) 574-4645
www.cityofwarren.org

FROM: Mayor, Planning Commission and Planning Director

RE: PROPOSED DRAFT FOR THE CITY OF WARREN VAN DYKE CORRIDOR PLAN; AN ADDENDUM TO THE CITY OF WARREN MASTER PLAN; A comprehensive initiative for a rigorous three-year study encompassing resident and business surveys, as well as strategic engagements with key stakeholders, including City, County, and State officials. By February 2022, Beckett & Raeder, Inc. completed their preliminary study of the Van Dyke Corridor. This proposal is for a resolution to adopt and recommend to City Council and is an addendum to the 2021 City of Warren Master Plan; City of Warren; Tom Bommarito, DDA/TIFA Director (Beckett & Raeder, Inc., Planning Consultants).

At a public hearing on March 25, 2024, the Planning Commission adopted a resolution pertaining to the above-captioned matter. The resolution, as adopted, is a recommendation to the City Council to APPROVE the City of Warren Van Dyke Corridor Plan.

You will find attached herewith a copy of the staff findings and recommendation, resolution, petitioner's letter, minutes and proposed draft in connection with this matter. A link to the draft can be found on the Planning Department webpage.

Please schedule this matter for formal action by the City Council. If you have any questions or need additional information, please contact the Planning Director, Ronald Wuerth.

Thank you for your cooperation in this matter.

Respectfully submitted,

Mahmuda Mouri
Commission Secretary

/mzm

Attachments

Read and Concur:

Mayor

**RESOLUTION FOR THE PROPOSED
CITY OF WARREN VAN DYKE CORRIDOR PLAN**

A regular meeting of the City Council of the City of Warren, Macomb County, Michigan held on _____, 2024, at 7 p.m. Eastern Daylight Savings Time in at the Warren Community Center, Warren, Michigan.

PRESENT: _____

ABSENT: _____

The following preamble and resolution was offered by Councilmember _____ and supported by Councilmember _____:

WHEREAS, on March 25, 2024, a public hearing was held before the Planning Commission wherein the proposed resolution for the City of Warren Van Dyke Corridor Plan was considered, and the Commission reviewed evidence concerning compliance with all laws and fines; and

WHEREAS, at said hearing on March 25, 2024, the Planning Commission recommended approval of the proposed resolution for the City of Warren Van Dyke Corridor Plan.

WHEREAS, the proposed draft of the City of Warren Van Dyke Corridor Plan is attached hereto.

NOW THEREFORE BE IT RESOLVED that the report of the Planning Department attached hereto be submitted to the City Council and the said resolution recommended for adoption.

AYES: _____

NAYS: _____

RESOLUTION DECLARED ADOPTED this _____ day of _____, 2024.

MINDY MOORE
Secretary of the Council

RESOLUTION

WHEREAS, on March 6, 2024, a notice was published in the Warren Weekly, a paper of general circulation in the City of Warren, that the Planning Commission would hold a public hearing in the Council Chamber at the Warren Community Center Auditorium, 5460 Arden, Warren, Michigan to consider a resolution for the proposed City of Warren Van Dyke Corridor Plan; and

WHEREAS, on March 25, 2024, a public hearing was held before the Planning Commission wherein the proposed resolution for the City of Warren Van Dyke Corridor Plan was considered, and the Commission reviewed evidence concerning compliance with all laws and fines; and

WHEREAS, at said hearing on March 25, 2024, the Planning Commission recommended approval of the proposed resolution for the City of Warren Van Dyke Corridor Plan.

WHEREAS, the proposed draft of the City of Warren Van Dyke Corridor Plan is attached hereto.

NOW THEREFORE BE IT RESOLVED that the report of the Planning Department attached hereto be submitted to the City Council and the said resolution recommended for adoption.

RESOLUTION adopted at the meeting of March 25, 2024.

PLANNING COMMISSION OF THE CITY OF WARREN



Warren Smith, Chair



Mahmuda Mouri, Secretary



PLANNING DEPARTMENT

ONE CITY SQUARE, SUITE 315

WARREN, MI 48093-5283

(586) 574-4687

Fax (586) 574-4645

www.cityofwarren.org

April 2, 2024

Tom Bommarito
DDA/TIFA Director

RE: PROPOSED DRAFT FOR THE CITY OF WARREN VAN DYKE CORRIDOR PLAN; AN ADDENDUM TO THE CITY OF WARREN MASTER PLAN; A comprehensive initiative for a rigorous three-year study encompassing resident and business surveys, as well as strategic engagements with key stakeholders, including City, County, and State officials. By February 2022, Beckett & Raeder, Inc. completed their preliminary study of the Van Dyke Corridor. This proposal is for a resolution to adopt and recommend to City Council and is an addendum to the 2021 City of Warren Master Plan; City of Warren; Tom Bommarito, DDA/TIFA Director (Beckett & Raeder, Inc., Planning Consultants).

Dear Mr. Bommarito:

At its meeting of March 25, 2024, the City of Warren Planning Commission voted to recommend for **APPROVAL** the above-described draft for the City of Warren Van Dyke Corridor Plan, subject to the standard conditions of the Planning Commission and more specifically:

- 1) Under Acknowledgements:
 - a) Change *Eddie Kabacinski, City Council* to *Eddie Kabacinski, former City Council*.
 - b) Change *James Cummins, Building Department* to *James Cummins, former Building Division*.
 - c) Change *Lucky Hage, TIFA Member* to *Lucky Hage, former TIFA Member*.
- 2) Figure 1-2: Van Dyke Corridor Study Area, page 8 shall be updated to show the southern boundary as Eight Mile Rd., and the northern boundary as Stephens Rd. **Shown this way throughout the document; perhaps they extend it to provide information pertaining to the adjacent communities (Center Line & Detroit) and the cohesiveness?**
- 3) Page 26; Map Key 15; add word "formerly" to Ed & Lil's Flower Shop.

Upon completion of the standard conditions, the Commission's final recommendation shall be forwarded to City Council for approval.

Should you have any questions, please do not hesitate to contact our office at 586-574-4687.

Sincerely,

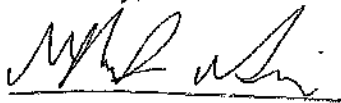
A handwritten signature in black ink, appearing to read 'Mahmuda Mouri', written over a horizontal line.

Mahmuda Mouri
Commission Secretary

/mzm

cc: Mayor
Ronald F. Wuerth, Planning Director
Mary Michaels, Chief Assistant City Attorney
Everett Murphy, Chief Zoning Inspector
James Kazanowski, Fire Department
Brian Barrick, Beckett & Raeder

6.b) PROPOSED DRAFT FOR THE CITY OF WARREN VAN DYKE CORRIDOR PLAN AN AMENDMENT TO THE CITY OF WARREN MASTER PLAN; TOM BOMMARITO, DDA/TIFA DIRECTOR.
PANAP240002
March 25, 2024
Page 1

FINDINGS

1. The last update to a plan related to the Van Dyke Corridor was approximately nineteen (19) years ago, in 2005 (City of Warren Downtown Development Authority Amended Development Plan and Tax Increment Finance Plan). Prior to the 2005 plan, there was a Van Dyke Corridor Plan Development Area No. 1 entitled, "Tax Increment Financing and Development Plan". The original plan was adopted December 1986 and the amended plan adopted February 1991. Beckett & Raeder, Inc., planning consultants.
2. **CURRENT STATUS OF THE AMENDMENT(S)**
 - a) Consistent with the provision of the Michigan Public Act 33 of 2008, as amended (the Michigan Planning Enabling Act). Section 45 extension, addition, revision, or other amendment to Master Plan; adoption; procedures; review and findings.
 - b) The present hearing will be the initial formal review of the proposed amendment by the Planning Commission.
 - c) On March 6, 2024, notice was given in the Warren Weekly for the March 25, 2024 public hearing before the Planning Commission. The notice indicates that the draft Van Dyke Corridor Plan is available on the Planning Department's website, and at each of the branch libraries (Civic Center, Miller, Busch, and Burnette).
 - d) On January 12, 2021, The City Council by formal motion, APPROVED the City of Warren Master Plan.

NOTE: The Master Plan contains information in Section 13 titled Integration and Implementation pertaining to neighborhoods, South Warren, redevelopment, and transportation, topics addressed in the corridor plan.

- e) The City of Warren Van Dyke Corridor Development Area No. 1 Tax Increment Financing and Development Plan was originally adopted December 1986, and amended February 1991.

3. **THE VAN DYKE CORRIDOR PLAN PROVIDES THE FOLLOWING SECTIONS:**

- a) Section 1: Assessment
 - Overview and Purpose
 - Physical Assessment and Summary
 - Existing Conditions and Function
 - Public Transportation
 - Non-motorized Transportation
 - Non-motorized Travel Improvements Opportunities

6.b) PROPOSED DRAFT FOR THE CITY OF WARREN VAN DYKE CORRIDOR PLAN AN AMENDMENT TO THE CITY OF WARREN MASTER PLAN; TOM BOMMARITO, DDA/TIFA DIRECTOR.

PANAP240002

March 25, 2024

Page 2

- Historic Resource Field Study and Summary
 - Land Use Survey and Summary
 - Structure Sensitivity & Total Vulnerability
 - Adopted Master Plan Future Land Use Policy
 - Economic Development Opportunities Along Van Dyke Corridor
 - Market Review and Summary
 - SEMCOG Traffic Analysis Meetings and Summary
 - Regulatory Review & Summary
- b) Section 2: Community Engagement
- Community Survey
 - Stakeholder Engagement
 - Key Takeaways
- c) Section 3: Physical Design Plan
- Corridor Design Specifics
 - Corridor Design Overview
 - Design
 - Community Branding
 - MDOT/SEMCOG Multi-Modal Tool
- d) Section 4: Land Use Strategy
- Opportunities and Constraints
 - Land Use Strategy
- e) Section 5: Implementation Strategy
- Zoning Recommendations
 - Design Implementation
 - Phasing & Cost Opinions
 - Financing
- f) Appendix
- Appendix A: Historic Field Assessment
 - Appendix B: National Register Criteria for Evaluation
 - Appendix C: National Park Service Preservation Briefs
 - Appendix D: Secretary of the Interior's Standards for the Treatment of Historic Properties
 - Appendix E: Michigan SHPO Architectural Properties Identification Form
 - Appendix F: Historic Preservation Bibliography
 - Appendix G: Van Dyke Avenue Safety Countermeasures
 - Appendix H: Analysis Maps

6.b) PROPOSED DRAFT FOR THE CITY OF WARREN VAN DYKE CORRIDOR PLAN AN AMENDMENT TO THE CITY OF WARREN MASTER PLAN; TOM BOMMARITO, DDA/TIFA DIRECTOR.
PANAP240002
March 25, 2024
Page 3

5. **THE FOLLOWING LIST ARE SUGGESTIONS TO THE FINAL DRAFT VAN DYKE CORRIDOR PLAN:**

a) Under Acknowledgements:

- 1) Change *Eddie Kabacinski, City Council* to *Eddie Kabacinski, former City Council*.
- 2) Change *James Cummins, Building Department* to *James Cummins, former Building Department*.
- 3) Change *Lucky Hage, TIFA Member* to *Lucky Hage, former TIFA*.

b) Figure 1-2: Van Dyke Corridor Study Area, page 8 shall be updated to show the southern boundary as Eight Mile Rd., and the northern boundary as Stephens Rd. **Shown this way throughout the document; perhaps they extend it to provide information pertaining to the adjacent communities (Center Line & Detroit) and the cohesiveness?**

c) Page 26; Map Key 15; add word "formerly" to Ed & Lil's Flower Shop.

6.b) PROPOSED DRAFT FOR THE CITY OF WARREN VAN DYKE CORRIDOR PLAN AN AMENDMENT TO THE CITY OF WARREN MASTER PLAN; TOM BOMMARITO, DDA/TIFA DIRECTOR.
PANAP240002
March 25, 2024
Page 4

RECOMMENDATION

The purpose of the public hearing is for the Planning Commission to receive public comment. The Commission, in turn, recommends to the Planning Department and City Attorney for any suggested changes.

Therefore, it is recommended that the Van Dyke Corridor Plan be APPROVED conditionally with additional changes, and then forward the Commission's final recommendation to City Council for approval.

1) Under Acknowledgements:

- a) Change *Eddie Kabacinski, City Council* to *Eddie Kabacinski, former City Council*.
- b) Change *James Cummins, Building Department* to *James Cummins, former Building Division*.
- c) Change *Lucky Hage, TIFA Member* to *Lucky Hage, former TIFA Member*.

2) Figure 1-2: Van Dyke Corridor Study Area, page 8 shall be updated to show the southern boundary as Eight Mile Rd., and the northern boundary as Stephens Rd. **Shown this way throughout the document; perhaps they extend it to provide information pertaining to the adjacent communities (Center Line & Detroit) and the cohesiveness?**

3) Page 26; Map Key 15; add word "formerly" to Ed & Lil's Flower Shop.

- B. PROPOSED DRAFT FOR THE CITY OF WARREN VAN DYKE CORRIDOR PLAN; AN ADDENDUM TO THE CITY OF WARREN MASTER PLAN: A comprehensive initiative for a rigorous three year study encompassing resident and business surveys, as well as strategic engagements with key stakeholders, including City, County, and State officials. By February 2022, Beckett & Raeder, Inc. completed their preliminary study of the Van Dyke Corridor. This proposal is for a resolution to adopt and recommend to City Council and is an addendum to the 2021 City of Warren Master Plan; City of Warren; Tom Bommarito, DDA/TIFA Director (Beckett & Raeder, Inc., Planning Consultants).

PETITIONERS PORTION:

Mr. Tom Bommarito – Thank you Commissioners it's a pleasure to be here tonight, I am the City of Warren DDA and Tax Increment Finance Authority Director. We are very excited tonight to give you this plan, it's something we've been working on for about three years. You can see in the backup; I won't read all of the different things.

Brian from Beckett and Raeder has a great presentation tonight. I just thought we would talk about that the TIFA Board is excited to move forward. We've had meetings with MDOT and with the County and with SEMCOG about this plan. The next step would be with your adoption it would go to City Council with a formal resolution by City Council that would help us then apply for several State and Federal Grants to initiate this plan. Thank you for your time and I'd like to introduce Brian from Beckett and Raeder.

Mr. Brian Barrick – Good evening, Commissioners, again Brian Barrick partner with Beckett and Raeder. I'm here to give you a brief overview of the Van Dyke Corridor Plan, hopefully you've had a chance to look at the documents. We will give you a brief overview here tonight.

The study area ranges from Eight Mile on the south to Stephens Road at the Center Line border on the north. We looked at this area from several perspectives from an inventory perspective an assessment perspective and looking at both zoning ordinance and physical improvement recommendations.

As part of this progress, we've had a rigorous community engagement--

Chair Smith – Excuse me sir, we don't have anything on our screen to look at. One second, we have technical difficulties. We will take a 10 minute recess so we can figure out the technical difficulties because we want to be able to see the plan and all we are looking at is a blank screen. So just hold that thought.

At 7:07 p.m., meeting in recess.

At 7:15 p.m., the meeting continues.

Chair Smith – We have the technical difficulties resolved so we will get started with the meeting again.

CONTINUE PETITIONERS PORTION:

Mr. Brian Barrick – Picking up where we left off engagement methodology, we did have a rigorous community engagement process as part of this study. We had a series of State quarter engagement sessions in April of 2022, sessions involving business owners, city staff, TIFA Board Members, Beautification Commission Members as well as public school representatives. We had another series of sessions in July of 2022, and we also had continuous involvement with MDOT Department of Roads and SEMCOG throughout this process as they are also stakeholders in the Van Dyke Corridor.

We also developed an online community survey, I shouldn't say online, we developed a community survey to gauge current and future preferences regarding land use, business preferences mobility infrastructure improvements and redevelopment opportunities. That survey was hosted online as well as paper copies of that survey provided at the public libraries. We received 199 online responses and 4 paper responses to that survey. Of the responses we received 86% of them were fully completed, which is a good rate, so we are pretty happy with that.

There are a few slides here that show some graphics and some charts, if you want to flip forward to the slide that is titled with takeaways. All of that data boils down to a few simple points, one is that people felt that the existing corridor is uncomfortable and had safety concerns related to the balance of vehicular traffic versus pedestrian bicycles and other modes of transportation. Also the land uses within the corridor there was not the level of business mix that the community felt would best serve them. So generally, it's an uncomfortable place to walk, bike, or be present so those are the items that we thought to address.

We did a historic structure survey inventory and assessment as part of this study. There is a historic building stock within the corridor and tin structures that we felt were appropriate for adaptive reuse. In developing land use strategies, we sought to develop ordinance suggestions for ordinance revisions that would support mixed use and housing. The current ordinance has some deficiencies that discourage those uses. Looking at tools for historic redevelopment of the structures that I mentioned and then developing a business mix in particular zones of the district to highlight particular interests by the community. A bike hub with

connection and prominence on the Iron Belle Trail, entertainment district, and a youth zone. On this side there's a chart that shows different categories of businesses and it lists the amount of dollars that is needed versus what is provided and you can see that the categories towards are business types which could lead to greater success within the corridor namely general merchandising, clothing, etc.

On the next slide we looked at mobility strategies for recommendations looking at complete street concept to rebalance the use of the corridor in an appropriate way for all transportation modes and users. The diagram on the top of the slide indicates additional crosswalk locations, mid walk crossings and improved safety at existing cross walks. Increasing the permeability of the Van Dyke Corridor crossing from east to west as well as introducing pedestrian refuge areas protected by plants and transit user amenities. The cross section on the bottom portion of the slide indicates a cross section that we are proposing. Looking at median plantings and portions of what is the center left turn lane today. Introducing the protected landscape islands protecting the bike lanes on the outer curbs and then introducing pedestrian improvements on the sidewalks with lighting, plantings, etc.

On the next slide this illustrates some of those mobility strategies. The center top photo is protected landscape island protecting the bike lane. Introducing our RFB signals and other safety improvements like cross walks again increasing the permeability of the Van Dyke Corridor from east to west from the neighborhoods to critical goods and services. Also looking at increasing the comfort and useability of transit through the corridor providing shelters, seating, information, live bus routing etc., at bus stop locations.

And then moving on to design and activation strategies, looking at opportunities to introduce green infrastructure within the corridor creating a diversity of landscaping elements, tree canopy and then screening of parking lots to increase the sustainability as well as the pedestrian comfort within the corridor.

Related to that, looking at opportunities to introduce public sculpture, murals, branding, outdoor dining again these community amenities that help increase the comfort of the corridor and improve the business environment. The vacant lots that are present looking at ways to activate those until such time as a redevelopment opportunity comes along using temporary improvements and activations such as community gardens, markets, working with public art installations, working with those landowners to develop those temporary activation strategies until permanent redevelopment can occur.

And on the final slide here is the summary of implementation strategies where we have grouped improvements into different cost tiers indicating that incremental steps can be made based upon funding that is available. As Tom mentions the goal is to seek grant opportunities and the desire of the TIFA Board is to really pursue the tier three improvements that have the most impact and the most benefit to the corridor and the community. With that being said there are opportunities to take incremental steps towards that using the lower cost to your improvements until such time as funding is available for the tier three improvements.

So we do have some phasing strategies and funding opportunities included within the overall report draft for adoption. Tom and I are happy to address any questions that you might have.

Secretary Mouri – There is no correspondence.

Mr. Ron Wuerth reads the recommendations of the Staff:

MOTION:

A motion was made by Vice Chair Boniecki to approve, supported by Commissioner Ansar.

COMMISSIONERS PORTION:

Commissioner Robinson – How soon would the grant writing proposals be started?

Mr. Tom Bommarito – We've technically already begun some of those. You may have heard we have a new building going up on Continental and Van Dyke, Urgent Care Building, apartments above, that was part of a 1.8 million dollar grant we got from the State of Michigan. So we are constantly looking for those, but specifically as you saw in the presentation this calls for a greening of that area and there's a lot of those grants available right now so with your approval and then Council's we will go after those infrastructure grants as soon as we get the final approval from Council.

Commissioner Robinson – Okay great.

Chair Smith – On page 67 it showed Civic Center South and next to it showed a bike hub, right now that's where the new fire department is going to be going. I guess the Urgent Care is going to be next to that, so that might be something that needs to be added to it also.

The other thing is we have noticed in our neighborhood, I don't know how far it's extending out but they have license plate readers scattered

throughout the neighborhood. I have an idea why but I was trying to figure out how they set up and where to put them.

Mr. Tom Bommarito – Along the corridor you’re speaking of?

Chair Smith – No, outside of the corridor.

Mr. Tom Bommarito – Those I’m not sure what they are, I’m not sure they are license plate readers. In the neighborhoods with the little solar thing and the purple light?

Chair Smith – Right.

Mr. Tom Bommarito – I’m not sure what those are, that’s not part of this. On the TIFA Corridor we did install about 12 cameras they are not license plate readers but they are taking photos of the cars going up and down Van Dyke and it’s more of an investigative tool for the police department if something happens on the corridor they will have some cameras. That’s the only thing that we’ve set up.

Chair Smith – So they really wouldn’t have to contact TIFA to put these in the neighborhood, right?

Mr. Tom Bommarito – Again the TIFA district on that little booklet the red outline along Van Dyke is the entire district. So our district is the business along the Van Dyke corridor and it only goes maybe 50 to 100 feet off of Van Dyke in both directions. So this is taking a little bit of tax dollars from the businesses on the corridor and then reinvesting it into the corridor to keep it vibrant is what we are hoping to do.

Chair Smith – Okay, because it does extend further than that in my neighborhood and I was just trying to figure out where the funding was as far as putting those in.

Mr. Tom Bommarito – That might be a police department thing.

Chair Smith – Okay, it’s not a problem but I was just concerned because I didn’t really know and I kind of understand what they are trying to do and it’s a good thing. Thank you, sir.

ROLL CALL:

The motion carried as follows:

- Vice Chair Boniecki..... Yes
- Commissioner Ansar..... Yes
- Commissioner Robinson..... Yes

Commissioner Tutt..... Yes
 Secretary Mouri..... Yes
 Chair Smith..... Yes

7. CORRESPONDENCE:

A. SITE PLAN FOR NEW MEDICAL OFFICE BUILDING AND ADITION TO EXISTING SURGICAL HOSPITAL: Located on the east side of Dequindre Road approximately 427.83 ft. north of John B Avenue; 21230 Dequindre Road; Section 31; John Vitale (Adam Roberts). **Approved on June 21st, 2021. Never finished expired.**

MOTION:

A motion was made by Commissioner Tutt to recognize as an expired site plan, supported by Commissioner Robinson.

ROLL CALL:

The motion carried as follows:

Commissioner Tutt..... Yes
 Commissioner Robinson..... Yes
 Commissioner Ansar..... Yes
 Secretary Mouri..... Yes
 Vice Chair Boniecki..... Yes
 Chair Smith..... Yes

B. SITE PLAN FOR BUILDING ADDITION FOR INDUSTRIAL STORAGE: Located on the east side of Groesbeck Highway, approximately 917.08 ft. north of Stephens Road; 24358 Groesbeck Highway; Section 25; Great White Dort Inc. (Ed Cutlip, AGS Automotive System). **Approved on August 9th, 2021. Never finished expired.**

MOTION:

A motion was made by Vice Chair Boniecki to recognize as an expired site plan, supported by Commissioner Robinson.

ROLL CALL:

The motion carried as follows:

Vice Chair Boniecki..... Yes
 Commissioner Robinson..... Yes
 Commissioner Tutt..... Yes
 Commissioner Ansar..... Yes
 Secretary Mouri..... Yes
 Chair Smith..... Yes



April 16, 2024

PLANNING DEPARTMENT

ONE CITY SQUARE, SUITE 315
WARREN, MI 48093-5283
(586) 574-4687
FAX (586) 574-4645
www.cityofwarren.org

TO: Mindy Moore, Council Secretary
Warren City Council

FROM: Ronald F. Wuerth, AICP
Planning Director

RE: REQUEST FOR PUBLIC ALLEY VACATION; located between Globe Avenue and Nagel Street; approximately 100 ft. south of Nine Mile Road; Section 35; 12000 Nine Mile; Matt Knio; PEV210001

I have reviewed the attached request from Mr. Matt Knio, President of Golden Wheat, Inc., to extend the initial two (2) year time period, as "conditioned", to complete the above-mentioned alley vacation. The initial two (2) year time period began on August 10, 2021 and expired on August 10, 2023.

The petitioner is requesting an extension of an additional two (2) year time period. Mr. Knio indicates that it should not take more than twelve (12) months to complete the project, but the additional time period would help in case of any issues that may materialize.

I am recommending that City Council consider the two (2) year extension request. The time period would begin on August 10, 2023, when the first two (2) year time period expired, and end on August 10, 2025.

Mr. Knio will attend the City Council meeting if you choose to consider this request.

Should you have any questions regarding details of the original request, please contact me directly.

/mzm

Attachment

cc: Mayor Stone
Warren Planning Commission
Mary Kamp



April 15, 2024

Ronald Wuerth
Planning Director
City of Warren
One City Square, Suite 315
Warren, MI 48089

Dear Mr. Wuerth,

Per my application, an alley vacation was approved by City Council on August 10, 2021. The alley in question is located between Globe Avenue and Nagel Street; approximately 100 ft. south of Nine Mile Road. At the time, I had planned to demolish vacant houses on two parcels I own on Globe Street adjacent to the alley with the goal of constructing another building on the property.

The houses were demolished, and I was working with an architect, as well as the City, to create plans for the site. However, due to challenges in utilizing the site, I eventually purchased a supplemental building within the City to address my business needs.

Although my plans for the property have since changed, I would still like to utilize the portion of the alley that was vacated for my use. At this time, I would like to expand my gated parking lot to accommodate my employee parking needs. This will allow my business to expand its operational capabilities at its address and prevent the illegal dumping that has been happening on the now vacant lots. I would continue to permit DTE any and all access necessary for their business operations in the neighboring facility.

GW

To that end, I would appreciate if the original alley vacation could be extended for an additional 2-year period, so that I may pursue a site plan and secure any necessary permits prior to completing the project. I hope to complete the project within 12 months, but the additional time will ensure it is not rushed in any way. If you have any questions regarding this matter, I welcome the opportunity to speak with you regarding my business needs. I appreciate your consideration of this matter.

Regards,

Matt Knio

President

Golden Wheat, Inc.



End of Item 11



COMMUNITY DEVELOPMENT

ONE CITY SQUARE, SUITE 210
WARREN, MI 48093
(586) 574-4686
FAX (586) 574-4685
www.cityofwarren.org

May 20, 2024

Mindy Moore, Council Secretary

RE: Proposed Resolution Authorizing an Agreement between the City of Warren and Macomb Community Action for Grass & Snow Services.

As part of the CDBG Program Year Budget, funds in the amount of \$40,000 have been allocated to provide grass and snow services for low and moderate income senior citizens and severely disabled adults residing in the City of Warren. The City desires to enter into a contract with the Macomb Community Action to provide such services to eligible Warren residents.

Attached for consideration by Council you will find a copy of the proposed agreement with Macomb Community Action, which was reviewed and approved by the City Attorney's Office. Please submit to Council for Consideration at its May 28, 2024 meeting. The appropriate resolution authorizing execution of the agreement for these services is also attached. If you have any questions regarding this matter, please contact Community Development at (586) 574-4686.

Sincerely,

for Tom Bommarito
Community Development Director

Read and Concur:

Lori M. Stone
Mayor

Read and Approved as to Form:

City Attorney's Office

**RESOLUTION TO APPROVE AGREEMENT BETWEEN THE CITY OF WARREN AND
THE MACOMB COMMUNITY ACTION
FOR GRASS AND SNOW SERVICES**

At a regular meeting of the City Council of the City of Warren, Macomb County, Michigan held on May 28, 2024, at 7:00 p.m. Eastern Time at the Warren Community Center, 5460 Arden, Warren, Michigan.

PRESENT: Councilmembers _____

ABSENT: Councilmembers _____

The following preamble and resolutions were offered by Councilmember _____ and supported by Councilmember _____.

The City is the recipient of Community Development Block Grant Funds under Title I of the Housing and Community Development Act of 1974 as amended. (Program Funds)

Program Funds for grass and snow services were previously allocated for qualified low and moderate income senior citizens and severely disabled adults, as defined by the U.S. Census Bureau, residing in the City of Warren.

The Macomb Community Action desires to provide such grass and snow services to qualified low and moderate income Warren residents.

The Mayor and Community Development staff recommend that the City enter into a contract with the County of Macomb, Macomb Community Action to provide grass and snow services to qualified Warren residents with Community Development Block Grant Funds.

Sufficient funding is available in the Senior Grass and Snow Line-Item No. 273-9850-80156-CD2304.

THEREFORE IT IS RESOLVED, that the Mayor and City Clerk are authorized to execute a contract for the period of July 1, 2024 through June 30, 2025 with the County of Macomb, Macomb Community Action, for grass and snow services up to the total amount of \$40,000. Such contract shall be in a form that meets with the approval of the City Attorney.

AYES: Councilmembers _____

NAYES: Councilmembers _____

RESOLUTION DECLARED ADOPTED THIS 28th day of June, 2024.

MINDY MOORE
Secretary of the Council

CERTIFICATION

STATE OF MICHIGAN)
)ss
COUNTY OF MACOMB)

I, Sonja Buffa, duly elected City Clerk for the City of Warren, Macomb County, Michigan, hereby certify that the foregoing is a true and correct copy of the resolution adopted by the Council of the City of Warren at its meeting held on May 28, 2024.

SONJA BUFFA
City Clerk

**GRASS & SNOW PROGRAM CONTRACT
BETWEEN MACOMB COMMUNITY ACTION
AND CITY OF WARREN FOR 2024/2025 PROGRAM YEAR**

This Agreement is made this _____ day of _____, 2024 between the City of Warren ("the CITY"), a Michigan municipal corporation, whose address is One City Square, Warren, Michigan 48093, and the County of Macomb ("MACOMB"), on behalf of the Macomb Community Action, whose address is 21885 Dunham Road, Suite 10, Verkuilen Building, and Clinton Township, Michigan 48036.

The parties stipulates as follows:

1. The CITY is the grant recipient of Community Development Block Grant ("CDBG") funds under Title I of the Housing and Community Development Act of 1974, as amended, hereinafter referred to as "the Funds". Federal Award Identification Number B-23-MC-26-0016 awarded on July 1, 2023. CFDA Number 14.218.
2. The CITY has appropriated \$40,000, a portion of the Funds, to provide home maintenance assistance to eligible residents under the CDBG Program requirements.
3. County of Macomb (MACOMB) (Unique Entity ID KZVMUQJJ4CJ7), develops, staffs, and implements a Grass and Snow Program, which provides home maintenance services to senior citizens and severely disabled adults.
4. MACOMB desires to offer such services to qualified residents in the City of Warren with funds available through the CDBG Program.
5. This Contract is considered a sub-award and will not be used for research and development. There will be no reimbursement for indirect cost related to this award.

For the reasons set forth above, and in consideration of the mutual covenants and promises of the parties, the CITY and MACOMB agree as follows:

SECTION 1. SCOPE OF SERVICES. MACOMB shall provide, in a good and professional manner, and in accordance with the provisions of this Contract, the following services:

1. MACOMB shall provide the residential maintenance services specified in this Agreement to eligible Warren residents ("Program Recipients"). Program Recipients eligible for assistance under this Agreement are defined as:
 - (a) At least sixty (60) years of age or a "severely disabled adult" as defined in the attached Addendum;
 - (b) Unable to perform residential maintenance work;
 - (c) No member or occupant of the household is physically or financially capable of providing the maintenance work; and
 - (d) Low to Moderate Income, as defined by the Department of Housing and Urban Development (HUD) and the City of Warren CDBG Program. These income limits may, at the CITY'S discretion, be revised. A copy of the current schedule of income limits is attached to this Agreement as Exhibit A. Any updates to this schedule will be mailed to MACOMB,
2. MACOMB shall provide the following types of maintenance services:
Lawn and yard maintenance and snow removal.

3. The services shall be performed in order of priority based upon availability of MACOMB's personnel and the need of the recipient.
4. MACOMB shall obtain from the Program Recipients written verification of their age at the time of their application.
5. MACOMB shall obtain from the Program Recipients written self-certification of income at time of application and annually thereafter.
6. MACOMB shall, for each Program Recipient, document the type, date, time and location of service, the Program Recipient's name, age, basis of eligibility, household income, and age of each household member.
7. MACOMB shall furnish the City with such other reports or statistics as the City may request to account for the activities under this Agreement.
8. MACOMB shall retain all records required under this Agreement for a period of five (5) years after expiration of this agreement.
9. MACOMB shall be responsible for obtaining any necessary permits or licenses required by federal, state, or local law.
10. MACOMB will maintain active status in the System for Award Management (SAM).

SECTION 2. TERM OF CONTRACT. The term of this contract shall be from July 1, 2024 to June 30, 2025, unless terminated sooner, as provided in this agreement.

SECTION 3. PERSONNEL AND MATERIALS.

1. MACOMB shall provide, all materials, tools, equipment, transportation and skilled and competent personnel and/or contractors necessary to perform, in a good and professional manner, all work and services required to be performed under this agreement.
2. MACOMB shall take reasonable precautions in the selection of individuals and/or contractors providing work under this agreement to ensure their honesty, courtesy, ability and fitness. MACOMB shall ensure that no solicitations are made to any person by any of its employees or contractors. Furthermore, MACOMB shall not allow persons at the work site other than its employees, contractors or agents engaged in services.
3. An employee of the City may not be hired to perform services under this contract. Any person performing work under this contract shall not be deemed an employee or independent contractor of the CITY.
4. All persons performing any service hereunder shall be qualified and licensed under federal, state and local law to perform such services.
5. MACOMB shall remove any debris, rubbish and materials after each maintenance service, and shall restore the premises to at least the same condition that existed prior to the work.

SECTION 4. ASSIGNMENTS AND SUBCONTRACTS. MACOMB may not assign any part of this contract without the prior knowledge and written consent of the CITY. Any assignments shall be mutually agreed upon by MACOMB and the CITY, and the assignee will be required to execute an assignment agreement with the City. Such assignment agreement must be approved by City Council for the CITY to be valid. Even if any part of this contract is assigned, MACOMB shall not be relieved from its responsibilities under this contract.

MACOMB may subcontract any or all of the work to be performed under this contract with prior knowledge and consent of the City's Community Development Director. Subcontractor must agree in writing to be bound by the terms of this contract including registration on the System for Award Management (SAM) prior to commencement of any work. Even if any work is subcontracted, MACOMB shall not be relieved from its responsibilities under this contract.

SECTION 5. SAFETY AND PROTECTION. MACOMB and any subcontractors shall provide the necessary protection and take all necessary precautions to prevent damage, injury, or loss to any person or property in the performance of any service under this agreement, and shall comply with all applicable safety laws to prevent injuries or accidents. All damage, injury or loss to any private or public property caused by work under this agreement shall be remedied, repaired or replaced by MACOMB at MACOMB's expense to the satisfaction of the City, within seven days' notice from the City. The City reserves all legal and equitable rights to compel performance or to seek compensatory damages for non-compliance.

SECTION 6. COMPENSATION. The total compensation to MACOMB under this Contract shall not exceed the maximum amount of \$40,000 (the Contract Amount). Compensation will be based upon the performance of maintenance services specified in Section 1, Paragraph 2 of this Contract. Compensation shall be at the following rates for services up to the Contract Amount:

Billing rate for grass:
Single Lot (less than 7200 square feet) -\$24.00
Double lot (7201 square feet – ½ acre) -\$32.00
Triple lot (1/2 acre – 1 acre) -\$44.00

Billing rate for snow:
Snow removal 2 inches to 6 inches - \$26.00
Snow removal over 6 inches - \$34.00
Inspection fee - \$5.00

MACOMB shall submit invoices at least quarterly to the CITY, itemizing the type of service and location. Such reports and invoices shall be submitted within twenty (20) days after each quarter ending September 30, December 31, March 31, and June 30. MACOMB will be entitled to compensation only for the maintenance services specified in Section 1, Paragraph 2 of this Contract. Any additional services must be approved in advance by the Community Development Director.

SECTION 7. INSURANCE. MACOMB, and any of its subcontractors, shall maintain and keep in effect during the term of this agreement, the following insurance policies:

1. Workers Compensation & Employers Liability Insurance in the statutory amounts required by the State of Michigan for all laborers and employees.
2. Comprehensive General Liability Insurance

\$1,000,000 per occurrence
\$2,000,000 General Aggregate for Bodily Injury and Property Damage

3. Comprehensive Motor Vehicle Liability
\$1,000,000 Combined Single Limit for Bodily Injury and Property Damage
4. Umbrella - Excess Coverage - \$2,000,000

The City shall be named as an additional insured on said Comprehensive General and Motor Vehicle Liability Insurance and stated on certificate as follows: **“The City of Warren, City of Warren Municipal Building Authority, City of Warren Downtown Development Authority and the 37th District Court, all elected, appointed officials, employees and volunteers as individuals acting within the scope of their authority, as an additional insured.”**

Certificates of insurance shall be submitted to the CITY prior to the commencement of work, must include a waiver of subrogation, and may not be canceled or materially changed without thirty (30) days prior notice to the City.

SECTION 8. TERMINATION FOR CAUSE

1. If, for any cause, MACOMB or the CITY shall fail to fulfill in a timely and proper manner its obligations under this agreement, or shall violate any of the covenants, agreements, or stipulations of this agreement, the CITY or MACOMB shall have the right to terminate this agreement by giving notice to the other party of such termination at least five (5) days before the effective date of such termination. MACOMB shall not commit to services or otherwise to the expenditure of Program Funds after receipt of the notice of termination.
2. Upon termination of this agreement, MACOMB or the CITY shall not be relieved of liability to the other party for any damages sustained by virtue of any breach of the agreement. The CITY may withhold any payments to MACOMB for the purpose of set off until such time as the exact amount of damages due the CITY from MACOMB is determined.

SECTION 9. CONFIDENTIALITY AND RETURN OF DOCUMENTS. Upon termination or expiration of this Agreement, all finished or unfinished documents, data, studies, surveys and reports prepared by MACOMB shall be transferred to the CITY. In addition, all reports and information prepared, used, or collected under this Agreement are confidential and shall not be made available to any individual, group or organization without the prior written approval of the CITY. This section shall survive termination of the agreement.

SECTION 10. TERMINATION FOR CONVENIENCE. The CITY may terminate this agreement at any time for any reason by giving at least thirty (30) days notice in writing to MACOMB. If the contract is terminated for convenience, MACOMB will be paid for the services provided and expenses incurred up to the termination. MACOMB shall not commit to services or otherwise to the expenditure of Program Funds after receipt of the notice of termination. If this Contract is terminated due to the fault of MACOMB, Section 8 shall apply.

SECTION 11. CHANGES. Any changes in services to be performed hereunder, including any increase or decrease in the amount of compensation, shall be mutually agreed upon by MACOMB and the CITY, and shall be incorporated into written amendments approved by the parties.

SECTION 12. INDEPENDENT CONTRACTOR. While carrying out the terms of this contract, MACOMB is an independent contractor and not an officer, employee or agent of the CITY.

MACOMB shall not at any time or in any manner represent that it or any of its agents or employees are agents or employees of the CITY. In addition, MACOMB shall be responsible for the acts or omissions of its employees.

Any participation of the CITY in the administration and/or implementation of this Agreement is for the sole purpose of ensuring compliance with CDBG goals and requirements and shall not be construed as giving rise to any employment, contractual or agency relationship with any person performing or receiving services under this Agreement.

SECTION 13. LIABILITY AND INDEMNITY.

1. MACOMB acknowledges that MACOMB and not the CITY is responsible for the performing its work under this Contract. MACOMB shall be responsible for any property damage or personal injury caused by, related to, or arising from its performance of this Contract or for the acts and omissions of MACOMB and its officers, employees and agents, except as provided below.
2. To the extent permitted by law, MACOMB shall indemnify and hold harmless the CITY, and its officers, employees and agents, for and from any liability, suits, demands, judgments and claims, including reasonable attorney fees and costs, for any personal injury or property damage arising from, or resulting from, its performance of this agreement, or from the violation of any law, ordinance or regulation.
3. All liability to third parties, loss or damages, demands, costs or judgments arising out of activities to be carried out by MACOMB in the performance of this agreement shall be the responsibility of MACOMB if the liability, loss, or damages are caused by, or arise out of, the actions or failure to act on the part of MACOMB or anyone directly or indirectly employed by MACOMB.

All liability to third parties, loss or damages, demands, costs or judgments arising out of activities or performance of the CITY under the terms of this agreement shall be the responsibility of the CITY if the liability, loss, or damage is caused by, or arises out of, the actions or failure to act on the part of the CITY or anyone directly or indirectly employed by the CITY.

In the event that liability to third parties, losses or damages arises as a result of activities conducted jointly by MACOMB and the CITY in fulfillment of their responsibilities under this Contract, such liability, loss or damage shall be borne by MACOMB and the CITY in relation to that party's responsibility for such liability, loss or damage under joint activities.

4. MACOMB shall hold the CITY harmless for any employment claim arising from or related to work performed under this Contract, including but not limited to claims related to workers compensation, insurance rights or liabilities, pension rights or liabilities and unemployment compensation.
5. Nothing in this agreement is to be construed as waiving any governmental immunity provided to the County of Macomb, Macomb Community Action, and City of Warren or their officers, employees or agents under the Governmental Liability for Negligence Act, MCL 691.1401, *et. seq.*, as amended, or by a court of law.
6. The indemnification obligations will survive termination.

SECTION 14. NOTICES. All invoices or notices under this Agreement shall be made by personal delivery or by first class mail, addressed to the CITY as follows:

City of Warren
Office of Community Development
One City Square, Suite 210
Warren, MI 48093

and addressed to MACOMB as follows:

Macomb Community Action
Grass and Snow Program
21885 Dunham Road, Suite 10
Verkuilen Building
Clinton Township, MI 48036

SECTION 15. COMPLIANCE WITH LAWS. MACOMB shall comply with all applicable laws, ordinances and codes of the federal, state, and local governments including but not limited to maintaining an active registration status with the System for Award Management (SAM).

SECTION 16. HEADINGS AND SEVERABILITY. The headings of the sections in this Contract are for convenience only and shall not be used to construe or interpret the scope or intent of the contract. If any part of this Agreement shall be found invalid, that part shall be severable, and remaining provisions shall have full force and effect.

SECTION 17. REPORTS AND INFORMATION. MACOMB, at all times and in such forms as the CITY may require, shall furnish the CITY with such periodic reports as it may request pertaining to the work or services, and/or statistics necessary for the CITY to complete its reporting obligations.

SECTION 18. FEDERAL AUDIT REQUIREMENTS, RECORDS, AND AUDITS. MACOMB shall maintain accounts and records, including personnel, property and financial records, adequate to identify and account for all costs pertaining to this Agreement and such other records as may be deemed necessary by the CITY to assure proper accounting for all project funds, both Federal and Non-Federal shares. MACOMB shall allow the CITY, or any authorized representative thereof, to inspect or audit these records, at any time upon request. MACOMB shall retain the records for five (5) years after the expiration of this Agreement, unless permission to destroy them sooner is granted by the CITY.

Financial management systems standards of MACOMB shall be in compliance 2 CFR Part 200, Uniform Administrative Requirements, Cost Principles, and Audit Requirements for Federal Awards and such other regulations as may be applicable to budgeting, use and reporting of federal funds.

SECTION 19. NONDISCRIMINATION. During the performance of this Agreement, MACOMB agrees as follows:

1. MACOMB and any of its subcontractors will not discriminate against any employee or applicant for employment because of race, religion, sex, color, national origin, age, height, weight, marital status, handicap and/or disability that is unrelated to the individual's ability to perform the particular job. MACOMB will take affirmative action to ensure that applicants

are employed, and that employees are treated during employment, without regard to their race, religion, sex, color, national origin, age, height, weight, marital status, handicap and/or disability that is unrelated to the individuals' ability to perform the particular job. Such action shall include, but not be limited to, the following: employment, upgrading, demotion, or transfer; recruitment or recruitment advertising; layoff or termination; rates of pay or other forms of compensation; and selection for training, including apprenticeship. MACOMB agrees to post in conspicuous places, available to employees and applicants for employment, notices setting forth this clause.

2. MACOMB will, in all solicitations or advertisements for employees placed by or on behalf of MACOMB state that all qualified applicants will receive consideration for employment without regard to race, religion, color, sex, national origin, age, height, weight, marital status, handicap and/or disability.
3. MACOMB will cause the foregoing provisions to be inserted in all subcontracts for any work covered by this Agreement so that such provisions will be binding upon each subcontractor, provided that the foregoing provisions shall not apply to contracts or subcontracts for standard commercial supplies or raw materials.
4. MACOMB will comply with all provisions of Executive Order 11246 of September 24, 1965, and of the rules, regulations and relevant orders of the Secretary of Labor.
5. MACOMB will furnish all information and reports required by Executive Order 11246 of September 24, 1965, and by the rules, regulations and orders of the Secretary of Labor, or pursuant thereto, and will permit access to its books, records, and accounts by the authorized representative of the CITY and the Secretary of Labor for purposes of investigation to ascertain compliance with such rules, regulations and orders.
6. In the event of MACOMB's noncompliance with the nondiscrimination clauses of this Agreement or with any such rules, regulations or orders, this Agreement may be canceled, terminated, or suspended in whole or in part and MACOMB may be declared ineligible for further Government contracts in accordance with procedures authorized in Executive Order 11246 of September 24, 1965, and such other sanctions may be imposed and remedies invoked as provided in Executive Order 11246 of September 24, 1965, or by rule, regulation, or order of the Secretary of Labor, or as otherwise provided by law.
7. MACOMB will include the provisions of paragraphs (1) through (6) of this section in every subcontract or purchase order unless exempted by rules, regulations or orders of the Secretary of Labor issued pursuant to Section 204 of Executive Order 11246 of September 24, 1965, so that such provisions will be binding upon each subcontractor or vendor. MACOMB will take such action with respect to any subcontract or purchase order as the authorized representative of the CITY may direct as a means of enforcing such provisions including sanctions for noncompliance.
8. In the event MACOMB becomes involved in, or is threatened with, litigation with a subcontractor or vendor as a result of such direction by the authorized representative of the CITY, MACOMB may request the United States to enter into such litigation to protect the interests of the United States.

SECTION 20. CERTIFICATION REGARDING LOBBYING. MACOMB certifies, to the best of its knowledge and belief, that:

1. No Federal appropriated funds have been paid or will be paid, by or on behalf of MACOMB, to any person for influencing or attempting to influence an officer or employee of any agency, a Member of Congress, an officer or employee of a Member of Congress in connection with awarding of any Federal contract, the making of any Federal grant or loan, the entering into of any cooperative agreement, and the extension, continuation, renewal, amendment or modification of any Federal contract, grant, loan or cooperative agreement.
2. If any funds other than Federal appropriated funds have been paid or will be paid to any person for influencing or attempting to influence an officer or employee or any agency, a Member of Congress, an officer or employee of Congress or any employee of a member of Congress in connection with this Federal contract, grant, loan or cooperative agreement, the undersigned shall complete and submit Standard Form-LL, "Disclosure Form to Report Lobbying" in accordance with its instructions.
3. MACOMB shall require that the language of this certification be included in the award document for all sub-awards at all tiers (including subcontracts, sub-grants, and contract under grants, loan and cooperative agreements) and that the sub-recipients shall certify and disclose accordingly.

SECTION 21. PATENTS AND COPYRIGHTS. During the performance of this Agreement, MACOMB agrees as follows:

The Federal Government and the City of Warren shall retain rights in any resulting invention in accordance with 37 CFR Part 401, "Rights to Inventions Made by Non-profit Organizations and Small Business Firms Under Government Grant, Contracts and Cooperative Agreements," and any implementing regulations issued by HUD.

The U. S. Department of Housing and Urban Development and the City of Warren reserve a royalty-free, nonexclusive, and irrevocable license to reproduce, publish or otherwise use, and to authorize others to use, for Federal or Local Government purposes: (1) The copyright in any work developed under this contract; and (2) Any rights of copyright to which the contractor purchases ownership through this contract.

SECTION 22. HEADINGS AND SEVERABILITY. During the performance of this Agreement, MACOMB agrees as follows:

The headings of the sections in this Agreement are for convenience only and shall not be used to construe or interpret the scope or intent of the Agreement or in any way affect same. If any section or provision of this Agreement shall be found invalid, that provision shall be separable, and remainder shall have force and effect.

SECTION 23. GOVERNING LAW. During the performance of this Agreement, MACOMB agrees as follows:

This Agreement shall be governed by, interpreted, and enforced in accordance with the laws of the State of Michigan, and in any court having jurisdiction over the property which is located in or whose district includes Macomb County, Michigan.

SECTION 24: APPENDIX A OF TITLE VI PLAN. During the performance of this Agreement, MACOMB agrees as follows:

A. COMPLIANCE WITH REGULATIONS. The contractor shall comply with Regulations relative to nondiscrimination in Federally-assisted programs of the Department of Transportation, Title 49, Code of Federal Regulations, Part 21, as they may be amended from time to time (hereinafter referred to as the Regulations), which are herein incorporated by reference and made a part of this contract.

B. NONDISCRIMINATION. The contractor, with regard to the work performed by it during the contract, shall not discriminate on the grounds of race, color, sex, or national origin in the selection, retention, and treatment of subcontractors, including procurements of materials in the discrimination prohibited by Section 21.5 of the Regulation, including employment practices when the contractor covers a program set for in Appendix B of the Regulations.

C. SOLICITATION FOR SUBCONTRACTS, INCLUDING PROCUREMENTS OF MATERIALS AND EQUIPMENT. In all solicitations either by competitive bidding or negotiation made by the contractor for work to be performed under a subcontract, including procurements of materials or leases of equipment, each potential subcontractor or supplier shall be notified by the contractor of the contractor's obligations under the contract and the Regulations relative to nondiscrimination on the grounds of race, color, or national origin.

D. INFORMATION AND REPORTS. The contractor shall provide all information and reports required by the Regulations, or directives issues pursuant thereto, and shall permit access to its books, records, accounts, other sources of information, and its facilities as may be determined by the State Highway Department or the Federal Highway Administration to be pertinent to ascertain compliance with such Regulations or directives. Where any information required of a contractor is in the exclusive possession of another who fails or refuses to furnish this information, the contractor shall so certify to the State Highway Department or the Federal Highway Administration, as appropriate, and shall set forth what efforts it has made to obtain the information.

E. SANCTIONS FOR NONCOMPLIANCE. In the event the contractor's noncompliance with the nondiscrimination provisions of this contract, the State Highway Department shall impose such contract sanctions as it or the Federal Highway Administration may determine to be appropriate, including, but not limited to:

1. Withholding payments to the contractor under the contract until the contractor complies and/or
2. Cancellation, termination or suspension of the contract, in whole or in part.

F. INCORPORATION OF PROVISIONS. The contractor shall include provisions of paragraphs (1) through (6) in every subcontract, including procurement of material and leases of equipment, unless exempt by the Regulations, or directives issued pursuant thereto. The contractor shall take such action with respect to any subcontract or procurement as the State Highway Department or the Federal Highway Administration may direct as a means of enforcing such provisions including sanctions for noncompliance: provided, however, that, in the event a contractor becomes involved in, or is threatened with, litigation with a subcontractor or supplier as a result of such direction, the contractor may request the State Highway Department to enter into such litigation to protect the interests of the State, and, in addition, the contractor may request the United States to enter into such litigation to protect the interests of the United States.

SIGNATURES

Signed in the presence of:

CITY OF WARREN:

By: _____
Lori M. Stone
Mayor

Date: _____

By: _____
Sonja Buffa
City Clerk

Date: _____

MACOMB COUNTY:

By: _____
Vicki Wolber
Deputy County Executive

Date: _____

ADDENDUM
GRASS & SNOW SERVICES CONTRACT

Definition Severely Disabled Adults:

Persons are classified as having a severe disability if they are at least 18 years of age, and either (a) have used a wheel-chair or another special mobility aid for at least six months prior to the service date; (b) are unable to perform one or more "functional activities" or need assistance with an "ADL" or "IADL"; (c) are physically incapable of performing household chores; or (d) have a selected condition including autism, cerebral palsy, Alzheimer's disease, senility, dementia, or mental retardation; or (e) are under 65 years of age and who are covered by Medicare or who receive SSI.

For the purposes of this definition, the term "functional activities" include seeing, hearing, having one's speech understood, lifting and carrying, walking up a flight of stairs, and walking. An ADL is an "activity of daily living" which includes mobility inside the home, getting in or out of bed or a chair, bathing, dressing, eating, and toileting. An IADL is an "instrumental activity of daily living" and includes exiting the home without human assistance, keeping track of money or bills, preparing meals, doing light housework, and using the telephone.



COMMUNITY DEVELOPMENT

ONE CITY SQUARE, SUITE 210
WARREN, MI 48093
(586) 574-4686
FAX (586) 574-4685
www.cityofwarren.org

May 20, 2024

Mindy Moore
Council Secretary

RE: Adoption of 2024-2025 Housing and Community Development Action Plan
Application for 2024-2025 CDBG, HOME, and HOPWA Funds

To apply for and receive Community Development Block Grant (CDBG), HOME Investment Partnerships Program (HOME) and Housing Opportunities for Persons with AIDS (HOPWA) formula grant (entitlement) funds, the City must prepare and submit to HUD a *Housing and Community Development Action Plan*. The Action Plan is a component of the City's five-year *Housing and Community Development Consolidated Plan*. The Action Plan identifies the resources available to the City to achieve the objectives and implement the strategies in the Consolidated Plan. It lists the specific actions or projects that will be undertaken with the available resources to implement the strategies. It also indicates the measurable outcomes or accomplishments that can be expected from the completion of each project. Once Council approves the Plan these projects cannot be changed unless a formal Plan Amendment is adopted.

The 2024-2025 Proposed Action Plan was made available for public comment for a thirty-day period that ended April 12, 2024. On April 9, 2024, a public hearing was held before Council to receive input on the Proposed Plan. The Proposed Plan was adjusted to account for the actual allocation award from HUD. All of the comments received at the public hearing are summarized and will be attached to the Final Action Plan. The comments received during the development of the Action Plan are summarized and attached for your convenience.

The Action Plan must be approved by City Council and submitted to HUD as soon as possible in order for the City to continue to receive CDBG, HOME, and HOPWA formula grant funds. At this time, it is requested that Council adopt a resolution at its May 28th meeting approving the 2024-2025 Housing and Community Development Action Plan and authorizing submission of CDBG, HOME, and HOPWA funding applications to HUD for the 2024-2025 program year. The appropriate resolution is attached for your convenience. Should you have any questions regarding this matter, please feel free to contact call Community Development at 574-4686.

Sincerely,

for Tom Bommarito
Community Development Director

Read and Concur:

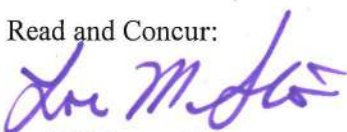
Lori M. Stone, Mayor

Read and approved as to form:

Attorney's Office

**RESOLUTION TO ADOPT 2024-2025 CITY OF WARREN HOUSING AND
COMMUNITY DEVELOPMENT ACTION PLAN,
AUTHORIZE APPLICATION FOR 2024-2025 COMMUNITY DEVELOPMENT BLOCK GRANT
(CDBG), HOME INVESTMENT PARTNERSHIPS (HOME) AND HOUSING OPPORTUNITIES FOR
PERSONS WITH AIDS (HOPWA) PROGRAM FUNDS**

At a regular meeting of the City Council of the City of Warren, Macomb County, Michigan held on May 28, 2024 at 7:00 p.m. Eastern Time in the Warren Community Center, 5460 Arden, Warren, Michigan.

PRESENT: Councilmembers _____

ABSENT: Councilmembers _____

The following preamble and resolutions were offered by Councilmember _____ and supported by Councilmember _____:

The City of Warren is eligible to apply for grant funds made available through the Community Development Block Grant (CDBG) Program enacted under Title I of the Housing and Community Development Act of 1974 as amended, through the HOME Investment Partnerships (HOME) Program enacted under Title II of the Cranston-Gonzalez National Affordable Housing Act, as amended, and through the Housing Opportunities for Persons with AIDS (HOPWA) Program enacted under Title VIII of the Cranston-Gonzalez National Affordable Housing Act, as amended.

The regulations enacted by the U.S. Department of Housing and Urban Development (HUD) to implement the Housing and Community Development Act of 1992 as amended require that CDBG, HOME and HOPWA Program applicants adopt a five-year Housing and Community Development Consolidated Plan that contains goals, objectives and strategies to meet priority housing and community development needs and a one-year action plan identifying the specific activities that will be undertaken to achieve the goals and objectives.

The Community Development Staff has an approved Housing and Community Development Consolidated Plan which satisfies the requirements identified by HUD. The Plan contains four objectives established to meet the City's priority housing and community development needs, and a fifth objective to meet the housing needs of Persons Living with HIV/AIDS (PLWH/A) in the Warren eligible metropolitan area which includes Lapeer, Livingston, Macomb, Oakland, and St. Clair Counties (Warren EMA). The objectives listed in priority are as follows:

1. Preserve existing single family neighborhoods.
2. Preserve existing single family housing stock.

3. Encourage homeownership among very low, low, and moderate income households and provide these households with opportunities to purchase affordable, decent, safe, and sanitary housing.
4. Encourage and cooperate with providers of shelter and support services for the homeless and providers of homeless prevention services.
5. Provide income eligible PLWH/A in the 5 county Warren EMA with access to permanent, stable, decent, and affordable housing.

The City intends to achieve the identified objectives with the following revenues anticipated for the 2024-202 Program Year, including reallocated funds from prior action plans:

<u>2024-2025 CDBG Revenues</u>	
<u>Source</u>	<u>Amount</u>
2024-2025 Formula Allocation	\$1,042,198.00
2024-2025 Program Income (Rehabilitation Loan Repayments – Estimate)	150,000.00
Total	\$1,192,198.00

<u>2024-2025 HOME Revenues</u>	
<u>Source</u>	<u>Amount</u>
2024-2025 Formula Allocation	\$451,572.00
2024-2025 Program Income (Sale of Homes and Repayment of Rehabilitation Loans - Estimated)	322,000.00
Total	\$773,572.00

<u>2024-2025 HOPWA Revenues</u>	
<u>Source</u>	<u>Amount</u>
2024-2025 Formula Allocation	\$1,411,277.00
Total	\$1,411,277.00

The City proposes to undertake the following activities with the 2024-2025 available resources:

Proposed 2024-2025 CDBG Activities

Activity Number/Name	Location	Formula Grant Funds	Program Income	Total Activity Funds
24-01 Residential Rehab - Owner Occupied Housing	City-wide	150,000.00	120,000.00	270,000.00
24-02 Rehab Delivery	City-wide	110,000.00	0.00	110,000.00
24-03 Enforcement Property Maintenance and Rental Registration Codes	South of Nine Mile Road	90,000.00	0.00	90,000.00
24-04 MCCSA- Senior Citizen Grass & Snow Program	City-wide	40,000.00	0.00	40,000.00
24-05 Homeless Prevention (St. Vincent de Paul)	City-wide	30,000.00	0.00	30,000.00
24-06 Shelter & Services for Victims of Domestic Violence (Turning Point)	City-wide	15,000.00	0.00	15,000.00
24-07 Homeless Shelter (MCREST)	City-wide	15,000.00	0.00	15,000.00
24-08 Advocacy for Victims of Child Abuse (Care House)	City-wide	40,000.00	0.00	40,000.00
24-09 Hearts for Homes	City-wide	10,000.00	0.00	10,000.00
24-10 Stillwell Manor Updates	South Van Dyke	164,000.00	0.00	164,000.00
24-11 Road Improvements	South Van Dyke	169,759.00	0.00	169,759.00
24-12 General Administration	N/A	207,939.00	30,000.00	237,939.00
24-13 Fair Housing	N/A	500.00	0.00	500.00
Total		1,042,198.00	150,000.00	1,192,198.00

Proposed 2024-2025 HOME Activities

Activity Number/Name	Location	Formula Grant Funds	Program Income	Total Activity Funds
H24-01 CHDO Housing Development	City-wide	67,735.80	0.00	67,735.80
H24-02 Home Owner Rehab	City-wide	125,000.00	289,800.00	414,800.00
H24-03 Housing Development	SE, SW, SVD	213,679.00		213,679.00
H24-04 Administration	N/A	45,157.20	32,200.00	77,357.20
Total		451,572.00	322,000.00	773,572.00

Proposed 2024-2025 HOPWA Activities

Activity Number/Name	Location	Formula Grant Funds	Total Activity Funds
WA 24-01 STRMU	EMA*	80,000.00	80,000.00
WA 24-02 Supportive Services	EMA	412,500.00	412,500.00
WA 24-03 Tenant Based Rental Assistance	EMA	250,000.00	250,000.00
WA 24-04 Administration	N/A	42,338.00	42,338.00
WA 24-05 Permanent Housing Placement (Move-In)	EMA	60,000.00	60,000.00
WA 24-06 Master Leasing	EMA	160,000.00	160,000.00
WA 24-07 Rehab/Acquisition	EMA	406,439.00	406,439.00
Total		1,411,277.00	1,411,277.00

* EMA – Warren eligible metropolitan area which includes Lapeer, Livingston, Macomb, Oakland, and St. Clair Counties

The Mayor and the Community Development staff recommend adoption of the *2024-2025 Housing and Community Development Action Plan* which incorporate the proposed CDBG, HOME and HOPWA activities as set forth above.

IT IS RESOLVED, that the City of Warren adopts the *2024-2025 Housing and Community Development Action Plan*.

IT IS FURTHER RESOLVED, that the Community Development Committee is authorized to adopt policies and procedures as necessary to administer activities in the 2024-2025 Action Plan, in such form that meets with the approval of the City Attorney.

IT IS FURTHER RESOLVED, that the Mayor of the City of Warren is authorized to perform the following responsibilities in connection with the *2024-2025 Housing and Community Development Action Plan*:

1. Act as the official representative and administrative authority on behalf of the Grantee, the City of Warren;
2. Execute the application to participate in the Community Development Block Grant Program under Title I of the Housing and Community Development Act of 1974, as amended.
3. Execute the application to participate in the HOME Investment Partnerships Program (HOME) Funds made available under Title II of the Cranston-Gonzalez National Affordable Housing Act, as amended.
4. Execute the application to participate in the Housing Opportunities for Persons with AIDS Program (HOPWA) funds made available under the AIDS Housing Opportunity Act, Subtitle D of Title VIII of the Cranston-Gonzalez National Affordable Housing Act, as amended.
5. Sign any documents in connection with the applications;
6. Sign and submit the *2024-2025 Housing and Community Development Action Plan* as adopted, including all understandings, assurances, and certifications contained therein; and to otherwise act in connection with the submission of the Plans and to provide such additional information, or modification, or amendments, as may be required.

AYES: Councilmembers _____

NAYES: Councilmembers _____

RESOLUTION DECLARED ADOPTED THIS 28th day of May, 2024.

MINDY MOORE
Secretary of the Council

CERTIFICATION

STATE OF MICHIGAN)
)ss
COUNTY OF MACOMB)

I, Sonja Buffa, duly elected City Clerk for the City of Warren, Macomb County, Michigan, hereby certify that the foregoing is a true and correct copy of the resolution adopted by the Council of the City of Warren at its meeting held on May 28, 2024.

SONJA BUFFA
City Clerk

**SUMMARY OF PUBLIC INPUT REGARDING DEVELOPMENT OF ACTION PLAN
INCLUDING REQUESTS FOR 2024-2025 FUNDS**

On January 10, 2024, an advertisement was published in the Warren Weekly indicating that the City was seeking input into the development of its 2024-2025 Housing and Community Development Action Plan HOPWA (Housing Opportunities for Persons with HIV/AIDS), HOME (HOME Investment Partnerships Program) and CDBG (Community Development Block Grant Program) Budgets. A special notice regarding only the HOPWA program was published in the Detroit News to reach all five counties (Lapeer, Livingston, Macomb, Oakland, and St. Clair) in the Warren EMA. The notices informed interested parties that they could submit comments directly to the City's Community Development staff or speak at public meetings scheduled as follows:

Meeting to Discuss HOPWA
Monday, January 29, 2024, at 10:00 a.m.
Warren City Hall – Township Room

Meeting to Discuss CDBG & HOME
Tuesday, January 30, 2024 at 10:00 a.m.
Warren City Hall – Township Room

Known affordable housing providers, housing support service providers and other parties who might have an interest in providing input into the development of the plan were sent individual notice of the meetings.

The following individuals were present at the January 29, 2024 HOPWA planning meeting:

- Gina Hensley, City of Warren Office of Community and Economic Development
- Angela Tarasenko, City of Warren Office of Community and Economic Development
- Patrice Garry, Oakland Livingston Human Service Agency
- Heather Zeigler, Oakland Livingston Human Service Agency
- Danielle Sparks, Oakland Livingston Human Service Agency

The following individuals were present at the January 30, 2024 CDBG & HOME planning meeting:

- Angela Tarasenko, City of Warren Office of Community and Economic Development
- Gina Hensley, City of Warren Office of Community and Economic Development
- Stacey Conte, Interfaith Volunteer Care Givers
- Dorie Vazquez-Nolan, Macomb County Child Advocacy Center/ Care House
- Sean Clark, Warren Housing Commission
- Faye Baker, Baker & Associates Realty

Requests for Funding from Additional Public Service Providers:

MCREST – Homeless Shelter
Amount Requested: \$18,000
Proposed Allocation: \$15,000

CARE HOUSE – Child Advocacy
Amount Requested: \$48,000

Proposed Allocation: \$40,000

Turning Point – Shelter for Victims of Domestic Violence

Amount Requested: - \$15,000

Proposed Allocation: - \$15,000

Society of St. Vincent de Paul – Homeless Prevention: Assistance with Utility, Rent and Mortgage Payments

Amount Requested: \$30,000

Proposed Allocation: 30,000

Macomb Community Action – Grass & Snow Program

Amount Requested: \$40,000

Proposed Allocation: \$40,000

Interfaith Volunteer Care Givers

Amount Requested: \$5,180

Proposed Allocation: \$0

Response: –The amount of funding the City receives is limited, and only activities that meet the highest priority needs to improve housing and neighborhoods are considered for funding.

Hearts for Homes

Amount Requested: \$25,000

Proposed Allocation: \$10,000

Empowerment & Development Housing Resource Center (EDHRC)

Amount Requested: \$50,000

Proposed Allocation: \$0

Response: EDHRC has a pending Community Housing Development Organization (CHDO) application with the City. Approved CHDO's may receive operating funding from the HOME grant. Due to limited grant funding, the City is unable to fund both requests.

Oakland Livingston Human Service Agency- (OLHSA, HOPWA Project Sponsor)

Amount Requested: \$962,500

Proposed Allocation: \$962,500

Written Requests for Funding from City Departments

The Engineering Division requested \$260,000 to fund the rehabilitation of Peters Ave. from Chalmers to Orchard. The proposed project entails: removal of existing deteriorated pavement and installation of new concrete pavement, along with some miscellaneous drainage, ADA sidewalk ramp improvements and related restoration.

Proposed Allocation: \$136,000

Response: This amount is being proposed to provide adequate funding for other projects.

The Controller's Office requested \$90,000 to fund continued efforts to enforce the property maintenance and rental registration codes.

Proposed Allocation: \$90,000

Warren Senior Housing requested \$164,000 for upgrades to Stillwell Manor. These improvements include maintenance and upgrades to the boiler system, and improvements to units for accessibility.



May 17, 2024

CITY ATTORNEY'S OFFICE

One City Square, Suite 400
WARREN, MI 48093
(586) 574-4671
FAX (586) 574-4530
www.cityofwarren.org

Ms. Mindy Moore
Council Secretary
City of Warren

Re: Proposed Resolution Approving Grant Application under the FY24 Law Enforcement Mental Health and Wellness Act (LEMHWA) Implementation Projects, and Authorizing Mayor and Clerk to Execute Memorandum of Understanding Relating to Grant Fund Expenditures

Dear Council Secretary Moore:

The City of Warren Police Department is eligible for grants funds in the approximate amount of \$200,000.00 from the Bureau of Justice Assistance under the FY24 Law Enforcement Mental Health and Wellness Act (LEMHWA) Implementation Projects.

If approved, the grant funds will help develop more effective community-oriented policing services. For example, the funds will support a social worker position to improve police and city relations with persons suffering from mental health issues, police wellness training and educational resources, and supplies for the citizens' police academy program.

The program narrative is attached for further explanation, along with the application form. They are also on file with the Clerk and City website. Also attached is a draft memorandum of understanding, which commits to the fund expenditure according to the Program Narrative. Please be advised that boilerplate changes may be required by the BJA.

If acceptable, please submit the proposed resolution, application and associated documents for Council consideration at its meeting on Tuesday, May 28, 2024.

Respectfully,

A handwritten signature in black ink, appearing to read "Mary Michaels".

Mary Michaels
Acting City Attorney

Approved:

A handwritten signature in blue ink, appearing to read "Charles Ruston".

Charles Ruston
Acting Police Commissioner

Approved:

A handwritten signature in blue ink, appearing to read "Lori M. Stone".

Lori M. Stone
Mayor

cc: Captain James Wolfe
Cpl. James Scwab

Richard Fox, Controller
Kristina Battle, Budget Director

ID/105660

**RESOLUTION APPROVING APPLICATION AND AUTHORIZING
MEMORANDUM OF UNDERSTANDING FOR 2024 LAW ENFORCEMENT
MENTAL HEALTH AND WELLNESS ACT IMPLEMENTATION PROJECT**

At a regular meeting of the City Council of the City of Warren, County of Macomb, Michigan held May 28, 2024, at 7 p.m. Eastern _____ Time in the Council Chambers at the Warren Community Center, 5460 Arden, Warren, Michigan.

PRESENT: Council Members: _____

ABSENT: Council Members: _____

The following preamble and resolution were offered by Council Member _____ and supported by Council Member _____.

The City of Warren Police Commissioner and Police Grant Coordinator applied for grant funding available from the U.S. Bureau of Justice Assistance ("BJA") designated as the FY24 Law Enforcement Mental Health and Wellness Act (LEMHWA) Implementation Projects.

If approved, the grant funds will support measures to improve community-oriented policing services, overall wellness of police officers, a social worker position to develop more effective relations with persons suffering from mental or behavioral issues, police wellness training, emotional survival materials, and supplies for the citizens police academy.

The BJA requires the City of Warren to enter into a memorandum of understanding to commit to the expenditure of funds according the grant application and Program Narrative.

The Application is available for public review in the Warren City Clerk's Office and on the City website.

THEREFORE, IT IS RESOLVED, that the Council of the City of Warren reviewed and approves the terms of the application for the FY24 Law Enforcement Mental Health and Wellness Act (LEMHWA) Implementation Projects grant.

IT IS FURTHER RESOLVED, that the Mayor and Clerk are authorized to execute the Memorandum of Understanding with the Bureau of Justice Assistance for the allocation, use and administration of LEMHWA grant funds, and such other associated documents as may be required under the grant program, in such form that meets with the satisfaction of the City Attorney.

FY24 Law Enforcement Mental Health and Wellness Act (LEMHWA) Implementation Projects

City of Warren MI. Police
CFDA: 16.710
Application # O-COPS-2024-171975
Grants.gov due 04/30/2024
JustGrants App due 04/24/2024

Applicant
City of Warren Michigan
Fiscal Agent
One City Square

Program Contacts

Program
Coordinator: Corporal James Schwab
Grant Administrator
(586) 574-4791 Fax (586) 574-4862
Jschwab@warrenpd.org

Financial
Coordinator: Kris Battle
City of Warren Controller's Office
(586) 574-4588
Kbattle@cityofwarren.org

Program Narrative

As a local law enforcement agency, the Warren Police Department is applying for one of the anticipated awards for the FY24 Law Enforcement Mental Health and Wellness Act (LEMHWA) Implementation Projects. The following describes how our agency will use the funds. Goals are to but not limited to; increase officer wellbeing, training to our community, and an addition of a Social Worker to assist the Warren Police Department, city workers, and citizens in our community with an advanced ability to cope with subjects suffering from mental, behavioral and emotional issues is evident and this social worker position will bridge this gap. Mental distress is at the root of many incidents which police are exposed to. This social worker will support and supplement sworn officers in supplying all possible resources to help the individual cope with their mental distress.

City of Warren Police Department

The City of Warren will utilize their award to fund training, equipment, travel to conferences and membership fees for our current Officer Wellness Program. (Actual cost unknown at this time). We would also purchase emotional survival for law enforcement training books and DVD's for the employees totaling \$9235.05. Simulated drunk driving and narcotic glasses to assist in training our Citizen Academy Program. (6 pack of glasses \$549.00) and add Social Worker to the Warren Police Department with an annual salary of \$70,000 per year and city provided vehicle at the cost of \$52,000.

Performance Measurement

Following the purchase of the equipment and implementation of these programs it will support our department through communicating with citizens, city employees, and officers, increasing officer safety, productivity, crime prevention, communication, and efficiency for the criminal justice system and to the service of the community. Performance measure reports will be reported quarterly in the BJA's BMT online website.

Timeline

Project will begin when the funding is available, training, policies & protocols will be implemented and approved by the Bureau of Justice Assistance (BJA). The purchase and program will be initiated within the grant cycle/program period.

Project Design and Implementation

This is not applicable for this project.

Capabilities and Competencies

This is not applicable to this project since there will be no planning or coordination with criminal justice juvenile justice agencies.

This Workspace form is one of the forms you need to complete prior to submitting your Application Package. This form can be completed in its entirety offline using Adobe Reader. You can save your form by clicking the "Save" button and see any errors by clicking the "Check For Errors" button. In-progress and completed forms can be uploaded at any time to Grants.gov using the Workspace feature.

When you open a form, required fields are highlighted in yellow with a red border. Optional fields and completed fields are displayed in white. If you enter invalid or incomplete information in a field, you will receive an error message. Additional instructions and FAQs about the Application Package can be found in the Grants.gov Applicants tab.

OPPORTUNITY & PACKAGE DETAILS:

Opportunity Number:	O-COPS-2024-171975
Opportunity Title:	FY24 Law Enforcement Mental Health and Wellness Act (LEMHWA) Implementation Projects
Opportunity Package ID:	[REDACTED]
CFDA Number:	16.710
CFDA Description:	Public Safety Partnership and Community Policing Grants
Competition ID:	
Competition Title:	
Opening Date:	02/29/2024
Closing Date:	04/24/2024
Agency:	Community Oriented Policing Services
Contact Information:	Office of Community Oriented Policing Services (COPS)

APPLICANT & WORKSPACE DETAILS:

Workspace ID:	[REDACTED]
Application Filing Name:	jschwab497
UEI:	[REDACTED]
Organization:	CITY OF WARREN
Form Name:	Application for Federal Assistance (SF-424)
Form Version:	4.0
Requirement:	Mandatory
Download Date/Time:	Apr 05, 2024 08:15:02 AM EDT
Form State:	No Errors

FORM ACTIONS:

Application for Federal Assistance SF-424

*** 1. Type of Submission:**

- Preapplication
- Application
- Changed/Corrected Application

*** 2. Type of Application:**

- New
- Continuation
- Revision

*** If Revision, select appropriate letter(s):**

*** Other (Specify):**

*** 3. Date Received:**

Completed by Grants.gov upon submission.

4. Applicant Identifier:

5a. Federal Entity Identifier:

5b. Federal Award Identifier:

State Use Only:

6. Date Received by State:

7. State Application Identifier:

8. APPLICANT INFORMATION:

*** a. Legal Name:**

City of Warren

*** b. Employer/Taxpayer Identification Number (EIN/TIN):**

386006931

*** c. UEI:**

d. Address:

*** Street1:**

29900 S Civic Center Blvd.

Street2:

*** City:**

Warren

County/Parish:

Macomb

*** State:**

MI: Michigan

Province:

*** Country:**

USA: UNITED STATES

*** Zip / Postal Code:**

48093-5285

e. Organizational Unit:

Department Name:

Warren Police Department

Division Name:

f. Name and contact information of person to be contacted on matters involving this application:

Prefix:

*** First Name:**

James

Middle Name:

*** Last Name:**

Schwab

Suffix:

Title:

Organizational Affiliation:

*** Telephone Number:**

586-574-4791

Fax Number:

*** Email:**

jschwab@warrenpd.org

Application for Federal Assistance SF-424

* 9. Type of Applicant 1: Select Applicant Type:

C: City or Township Government

Type of Applicant 2: Select Applicant Type:

Type of Applicant 3: Select Applicant Type:

* Other (specify):

* 10. Name of Federal Agency:

Community Oriented Policing Services

11. Catalog of Federal Domestic Assistance Number:

49010

CFDA Title:

Public Safety Partnership and Community Policing Grants

* 12. Funding Opportunity Number:

O-COPS-2024-171975

* Title:

FY24 Law Enforcement Mental Health and Wellness Act (LEMHWA) Implementation Projects

13. Competition Identification Number:

Title:

14. Areas Affected by Project (Cities, Counties, States, etc.):

Add Attachment

Delete Attachment

View Attachment

* 15. Descriptive Title of Applicant's Project:

Officer Wellness Program

Attach supporting documents as specified in agency instructions.

Add Attachments

Delete Attachments

View Attachments

Application for Federal Assistance SF-424

16. Congressional Districts Of:

* a. Applicant

* b. Program/Project

Attach an additional list of Program/Project Congressional Districts if needed.

Add Attachment

Delete Attachment

View Attachment

17. Proposed Project:

* a. Start Date:

* b. End Date:

18. Estimated Funding (\$):

* a. Federal	<input type="text" value="200,000.00"/>
* b. Applicant	<input type="text" value="0.00"/>
* c. State	<input type="text" value="0.00"/>
* d. Local	<input type="text" value="0.00"/>
* e. Other	<input type="text" value="0.00"/>
* f. Program Income	<input type="text" value="0.00"/>
* g. TOTAL	<input type="text" value="200,000.00"/>

* 19. Is Application Subject to Review By State Under Executive Order 12372 Process?

- a. This application was made available to the State under the Executive Order 12372 Process for review on
- b. Program is subject to E.O. 12372 but has not been selected by the State for review.
- c. Program is not covered by E.O. 12372.

* 20. Is the Applicant Delinquent On Any Federal Debt? (if "Yes," provide explanation in attachment.)

Yes No

If "Yes", provide explanation and attach

Add Attachment

Delete Attachment

View Attachment

21. *By signing this application, I certify (1) to the statements contained in the list of certifications** and (2) that the statements herein are true, complete and accurate to the best of my knowledge. I also provide the required assurances** and agree to comply with any resulting terms if I accept an award. I am aware that any false, fictitious, or fraudulent statements or claims may subject me to criminal, civil, or administrative penalties. (U.S. Code, Title 18, Section 1001)

** I AGREE

** The list of certifications and assurances, or an internet site where you may obtain this list, is contained in the announcement or agency specific instructions.

Authorized Representative:

Prefix: * First Name:
Middle Name:
* Last Name:
Suffix:

* Title:

* Telephone Number: Fax Number:

* Email:

* Signature of Authorized Representative: * Date Signed:

If you have questions please contact the Grants.gov Contact Center: support@grants.gov
1-800-518-4726 24 hours a day, 7 days a week. Closed on federal holidays.

The following application tracking information was generated by the system:

Grants.gov Tracking Number:	[REDACTED]
UEI:	[REDACTED]
Submitter's Name:	James C Schwab
CFDA Number:	[REDACTED]
CFDA Description:	Public Safety Partnership and Community Policing Grants
Funding Opportunity Number:	O-COPS-2024-171975
Funding Opportunity Description:	FY24 Law Enforcement Mental Health and Wellness Act (LEMHWA) Implementation Projects
Agency Name:	Community Oriented Policing Services
Application Name of this Submission:	jschwab497
Date/Time of Receipt:	Apr 05, 2024 08:17:07 AM EDT

TRACK MY APPLICATION – To check the status of this application, please click the link below:

https://www.grants.gov/applicants/grant-applications/track-my-application?tracking_num=GRANT14113393

It is suggested you Save and/or Print this response for your records.



May 21, 2024

CITY ATTORNEY'S OFFICE

One City Square, Suite 400

WARREN, MI 48093

(586) 574-4671

FAX (586) 574-4530

www.cityofwarren.org

Ms. Mindy Moore
Council Secretary
City of Warren

Re: 1) Proposed Resolution Granting DTE Electric Company and Overhead and Underground Easement and Approving an Easement Agreement for Properties at 7575, 7583 and 7591 Continental and Continental Parcel No. 13-28-483-022; 2) Proposed Resolution Granting DTE Energy an Overhead and Underground Easement and Approving an Easement Agreement for Property at 7592 Republic; Parcel No. 13-28-483-008; and 3) Request for Temporary Suspension of Council Rules 18.1 and 11.1 to Waive Reconsideration of Resolutions Granting the Easements

Dear Council Secretary Moore:

Attached please find two resolutions to grant DTE Electric Company utility easement in connection with the construction of Fire Station No. 1 at 23211 Van Dyke Ave. Upon approval and recording of the easements, DTE will remove existing utilities from the construction site.

The first resolution would grant a twelve (12') foot wide and eight (8') foot wide easement non-exclusive utility easement for the utilities as depicted in the drawings approved by DTE. The second resolution is for a three-foot wide easement upon 7592 Republic. DTE will install the utilities in coordination with the City Engineer.

The easements are critical to the Fire Station construction, and the removal of existing utility equipment from the construction site. Due to scheduling concerns, Council is requested to suspend Council Rules 18.1 and 11.1 to permit the waiver of its reconsideration period. Mitigating the delay by just a few days will have a cost-savings effect.

Please submit the resolutions and corresponding agreements to Council agenda for consideration at its meeting on May 28, 2024.

Respectfully submitted,

Mary Michaels
Acting City Attorney

cc: Wilburt McAdams, Fire Commissioner
Craig Treppa Purchasing Agent

Tina Gapshes, City Engineer
David Wirth, Civil Engineer

Approved:

Lori M. Stone, Mayor

RESOLUTION GRANTING DTE ELECTRIC COMPANY AN OVERHEAD AND UNDERGROUND EASEMENT AND APPROVING EASEMENT AGREEMENT FOR THE PROPERTY LOCATED AT 7575, 7583 AND 7591 CONTINENTAL AND CONTINENTAL PARCEL NO. 13-28-483-022

At a regular meeting of the City Council of the City of Warren, County of Macomb, Michigan, held on May 28, 2024, at 7:00 p.m. Eastern Daylight Savings Time, at the Warren Community Center 5460 Arden, Warren, Michigan.

PRESENT: Councilpersons _____

ABSENT: Councilpersons _____

The following preamble and resolution were offered by Councilperson _____ and supported by Councilperson _____:

The City of Warren has commenced construction of a new fire station located at 23211 Van Dyke Ave (Fire Station No. 1)

DTE Electric Company requires a non-exclusive easement on properties known as 7575, 7583 AND 7591 Continental and Continental Parcel No. 13-28-483-022 in the areas described in the attached documents entitled "DTE Electric Company Overhead and underground Easement (Right-of-Way) No. 69747899 SRW # 69747906-1 (Easement Agreement), and depicted on the parcel drawing denoted as Exhibit A of that Agreement (Easement).

The Easement would enable Detroit Edison to provide electrical services to the Fire Station NO. 1.

THEREFORE, IT IS RESOLVED, that the City grants the Detroit Electric Company the overhead and underground Easement and agrees to the terms of the Easement consistent with the attached Agreement.

IT IS FURTHER RESOLVED, that the Mayor and Clerk are authorized to execute the Easement Agreement, in such form that meets with the approval of the City Attorney and City Engineer, and any amendments as may be necessary in the future to correct administrative errors, consistent with this Resolution.

IT IS FURTHER RESOLVED, that the Easement Agreement shall be recorded with the Macomb County Register of Deeds.

IT IS FURTHER RESOLVED, that this Resolution shall take immediate effect and reconsideration is waived.

AYES: Councilpersons: _____

NAYS: Councilpersons: _____

RESOLUTION DECLARED ADOPTED this 28TH day of May, 2024.

MINDY MOORE
Council Secretary

CERTIFICATION

STATE OF MICHIGAN)
) SS.
COUNTY OF MACOMB)

I, SONJA BUFFA, duly elected City Clerk for the City of Warren, Macomb County, Michigan, hereby certify that the foregoing is a true and correct copy of the resolution adopted by the Council of the City of Warren at its meeting held on May 28, 2024.

SONJA BUFFA
City Clerk

RESOLUTION GRANTING DTE ELECTRIC COMPANY AN OVERHEAD AND UNDERGROUND EASEMENT AND APPROVING EASEMENT AGREEMENT FOR THE PROPERTY LOCATED AT 7592 REPUBLIC, PARCEL NO. 13-28-483-008

At a regular meeting of the City Council of the City of Warren, County of Macomb, Michigan, held on May 28, 2024, at 7:00 p.m. Eastern Daylight Savings Time, at the Warren Community Center 5460 Arden, Warren, Michigan.

PRESENT: Councilpersons _____

ABSENT: Councilpersons _____

The following preamble and resolution were offered by Councilperson _____ and supported by Councilperson _____:

The City of Warren has commenced construction of a new fire station located at 23211 Van Dyke Ave (Fire Station No. 1)

DTE Electric Company requires a non-exclusive easement on property at 7592 Republic, Parcel No. 13-28-483-008 in the areas described in the attached documents entitled "DTE Electric Company Overhead and underground Easement (Right-of-Way) No. 69747899 SRW # 69747906-2 (Easement Agreement), and depicted on the parcel drawing denoted as Exhibit A of that Agreement (Easement).

The Easement would enable Detroit Edison to provide electrical services to the Fire Station No. 1.

THEREFORE, IT IS RESOLVED, that the City grants the Detroit Electric Company the overhead and underground Easement and agrees to the terms of the Easement consistent with the attached Agreement.

IT IS FURTHER RESOLVED, that the Mayor and Clerk are authorized to execute the Easement Agreement, in such form that meets with the approval of the City Attorney and City Engineer, and any amendments as may be necessary in the future to correct administrative errors, consistent with this Resolution.

IT IS FURTHER RESOLVED, that the Easement Agreement shall be recorded with the Macomb County Register of Deeds.

IT IS FURTHER RESOLVED, that this Resolution shall take immediate effect and reconsideration is waived.

AYES: Councilpersons: _____

NAYS: Councilpersons: _____

RESOLUTION DECLARED ADOPTED this 28TH day of May, 2024.

MINDY MOORE
Council Secretary

CERTIFICATION

STATE OF MICHIGAN)
) SS.
COUNTY OF MACOMB)

I, SONJA BUFFA, duly elected City Clerk for the City of Warren, Macomb County, Michigan, hereby certify that the foregoing is a true and correct copy of the resolution adopted by the Council of the City of Warren at its meeting held on May 28, 2024.

SONJA BUFFA
City Clerk

DTE Electric Company Overhead and Underground Easement (Right of Way) No. 69747899 SRW# 69747906-1

On _____, 20____, for the consideration of system betterment, Grantor grants to Grantee a permanent, non-exclusive overhead and underground easement ("Right of Way") in, on, under and across that part of Grantor's Land to be referred to herein as the "Right of Way Area".

"Grantor" is: CITY OF WARREN, ONE CITY SQUARE, WARREN, MI 48093-6726.

"Grantee" is: DTE Electric Company, a Michigan corporation, One Energy Way, Detroit, Michigan 48226

"Grantor's Land" is in SE 1/4, Section 28, TIN-R12E, Warren Township, Macomb County and State of Michigan, and is described as follows:

Parcel# 12-13-28-483-019: PIPERS VAN DYKE SUB NO 2 LOT 372 L4 P51
Parcel# 12-13-28-483-020: PIPERS VAN DYKE SUB NO 2 LOT 373 L4 P51
Parcel# 12-13-28-483-021: PIPERS VAN DYKE SUB NO 2 LOT 374 L4 P51
Parcel# 12-13-28-483-022: PIPERS VAN DYKE SUB NO 2 LOT 375 L4 P51

Tax Identification Number(s): 12-13-28-483-019, 12-13-28-483-020, 12-13-28-483-021, AND 12-13-28-483-022
More commonly known as: 7575 CONTINENTAL WARREN, MI 48091
7583 CONTINENTAL WARREN, MI 48091
7591 CONTINENTAL WARREN, MI 48091
CONTINENTAL WARREN, MI 48091

The "Right of Way Area" is a **Twelve (12') foot wide easement and an Eight (8') foot wide easement** on part of Grantor's Land. The centerline of the Right of Way Area shall be established in the as-built location of the centerline of Grantee's facilities, and shall be installed on Grantor's Land in the approximate location described as follows:

THE LEGAL DESCRIPTIONS AND EASEMENT DRAWING IS MORE PARTICULARLY DESCRIBED ON EXHIBIT "A AND B" ATTACHED HERETO AND MADE A PART HEREOF.

- 1. Purpose:** The purpose of this Right of Way is to construct, reconstruct, modify, add to, repair, replace, inspect, operate and maintain overhead and underground utility facilities which may consist of underground vaults, pipelines, poles, guys, anchors, wires, manholes, conduits, pipes, cables, transformers and accessories.
- 2. Access:** Grantee has the right of pedestrian and vehicular ingress and egress to and from the Right of Way Area over and across Grantor's Land.
- 3. Buildings or other Permanent Structures:** No buildings or other permanent structures or improvements may be constructed or placed in the Right of Way Area without Grantee's prior, written consent. Grantor agrees, at its own expense, to remove any improvement that interferes with the safe and reliable operation, maintenance and repair of Grantee's facilities upon the written demand of Grantee. If Grantor fails to comply with such demand, Grantor agrees that Grantee may remove any such improvement and bill Grantor for the cost thereof, which cost Grantor shall pay within thirty (30) days after demand therefor.
- 4. Excavation:** Pursuant to 2013 Public Act 174, MISS DIG (1-800-482-7171 or 811 in some areas) must be called before any excavation in the Right of Way Area may proceed.

EXHIBIT A

2/26/2024 7:50 AM



Plot Order 69747899	Work Order Description 23211 VAN DYKE AVE, WARREN	GIS-DBN 69747904	DBN 69747906	RSO 69747919	PCB 69747924
Service Center MTC	Parcel ID CENTR2440	Parcel No.	Parcel Area 69747926	Parcel Date 3/8/24	Parcel Status NONE
Work Order City WARREN	Work Order State MI	Work Order County WARREN	Work Order Zip 48090	Work Order Date 2/26/2024	Work Order Time 7:50 AM
Drawn 01N 12E 28	Plotted Clark, Danielle L	734.280.0062	Scale 1452057	Version 1	Print Date 3/8/24

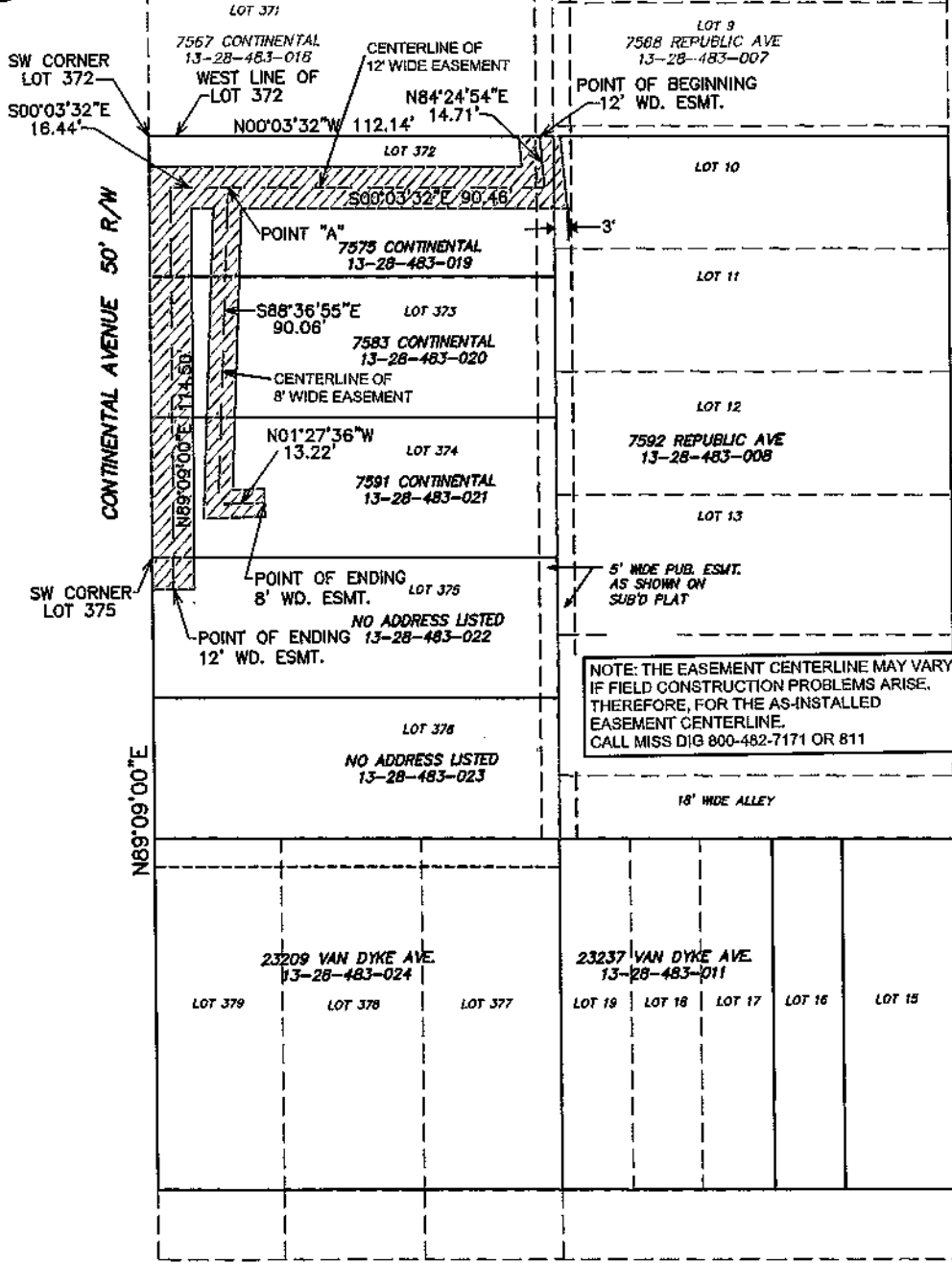

NOTE: THE EASEMENT CENTERLINE MAY VARY IF FIELD CONSTRUCTION PROBLEMS ARISE. THEREFORE, FOR THE AS-INSTALLED EASEMENT CENTERLINE, CALL MISS DIG 800-482-7171 OR 811

V:\202401\20240171\F\20240171_dte_easement.dwg

Piggott, Robert

VAN DYKE AVENUE VARIABLE' R/W

JOB NO. 20240171	HUBBELL, ROTH & CLARK, INC CONSULTING ENGINEERS SINCE 1915	555 HULET DRIVE BLOOMFIELD HILLS, MICH.	P.O. BOX 824 48303 - 0824	SHEET NO. 1
DATE 02/23/24		PHONE: (248) 454-6300 FAX (1st Floor): (248) 454-6312 FAX (2nd Floor): (248) 454-6359 WEB SITE: www.hrcengr.com	OF 2	

EXHIBIT B

OVERALL PROPERTY DESCRIPTIONS

PARCEL 13-28-483-019
LOT 372 OF "PIPERS VAN DYKE SUB No. 2", PART OF THE SOUTHEAST QUARTER OF SECTION 28, T.1N., R.12E., CITY OF WARREN, MACOMB COUNTY, MICHIGAN AS RECORDED IN LIBER 4, PAGE 51, MACOMB COUNTY RECORDS.

PARCEL 13-28-483-020
LOT 373 OF "PIPERS VAN DYKE SUB No. 2", PART OF THE SOUTHEAST QUARTER OF SECTION 28, T.1N., R.12E., CITY OF WARREN, MACOMB COUNTY, MICHIGAN AS RECORDED IN LIBER 4, PAGE 51, MACOMB COUNTY RECORDS.

PARCEL 13-28-483-021
LOT 374 OF "PIPERS VAN DYKE SUB No. 2", PART OF THE SOUTHEAST QUARTER OF SECTION 28, T.1N., R.12E., CITY OF WARREN, MACOMB COUNTY, MICHIGAN AS RECORDED IN LIBER 4, PAGE 51, MACOMB COUNTY RECORDS.

PARCEL 13-28-483-008
LOT 10 EXCEPT THE WEST 3.0 FEET AND ALL OF LOTS 11 TO 14 INCLUSIVE OF "ROTHS SUBDIVISION OF LOT 341 OF PIPERS VAN DYKE SUB No. 2", PART OF THE SOUTHEAST QUARTER OF SECTION 28, T.1N., R.12E., CITY OF WARREN, MACOMB COUNTY, MICHIGAN AS RECORDED IN LIBER 9, PAGE 50, MACOMB COUNTY RECORDS.

DTE EASEMENT DESCRIPTION

A 12' WIDE EASEMENT DESCRIBED AS BEGINNING AT A POINT ON THE WEST LINE OF LOT 372, WHICH IS NORTH 00 DEGREES 03 MINUTES 32 SECONDS WEST 112.14 FEET FROM THE SOUTHWEST CORNER OF SAID LOT 372 OF "PIPERS VAN DYKE SUB No. 2", PART OF THE SOUTHEAST QUARTER OF SECTION 28, T.1N., R.12E., CITY OF WARREN, MACOMB COUNTY, MICHIGAN AS RECORDED IN LIBER 4, PAGE 51, MACOMB COUNTY RECORDS; THENCE NORTH 84 DEGREES 24 MINUTES 54 SECONDS EAST 14.71 FEET; THENCE SOUTH 00 DEGREES 03 MINUTES 32 SECONDS EAST 90.46 FEET ALONG A LINE WHICH IS PARALLEL TO THE WEST LINE OF SAID LOT 372 TO POINT "A"; THENCE CONTINUING SOUTH 00 DEGREES 03 MINUTES 32 SECONDS EAST 16.44 FEET; THENCE NORTH 89 DEGREES 09 MINUTES 00 SECONDS EAST 114.50 FEET ALONG A LINE WHICH IS 6 FEET NORTH OF AND PARALLEL TO THE NORTH LINE OF CONTINENTAL AVENUE (50' RIGHT OF WAY) TO THE POINT OF ENDING;

ALSO AN 8' WIDE EASEMENT DESCRIBED AS BEGINNING AT SAID POINT "A"; THENCE SOUTH 88 DEGREES 36 MINUTES 55 SECONDS EAST 90.06 FEET; THENCE NORTH 01 DEGREES 27 MINUTES 36 SECONDS WEST 13.22 FEET TO THE POINT OF ENDING.

CONTAINS 3,609 SF

2/26/2024 7:50 AM

V:\202401\20240171\F\20240171_dte_easement.dwg

Piggott, Robert

JOB NO. 20240171	 HUBBELL, ROTH & CLARK, INC CONSULTING ENGINEERS SINCE 1915	555 HULET DRIVE BLOOMFIELD HILLS, MICH.	P.O. BOX 824 48309 - 0824	SHEET NO.
DATE 02/23/24		PHONE: (248) 454-6300 FAX (1st. Floor): (248) 454-6312 FAX (2nd. Floor): (248) 454-6359 WEB SITE: www.hrcengr.com	2	OF 2

DTE Electric Company Overhead and Underground Easement (Right of Way) No. 69747899 SRW# 69747906-2

On _____, 20____, for the consideration of system betterment, Grantor grants to Grantee a permanent, non-exclusive overhead and underground easement ("Right of Way") in, on, under and across that part of Grantor's Land to be referred to herein as the "Right of Way Area".

"Grantor" is: CITY OF WARREN, ONE CITY SQUARE, WARREN, MI 48093-6726.

"Grantee" is: DTE Electric Company, a Michigan corporation, One Energy Way, Detroit, Michigan 48226

"Grantor's Land" is in SE 1/4, Section 28, T1N-R12E, Warren Township, Macomb County and State of Michigan, and is described as follows:

ROTHS SUBDIVISION OF LOT 341 OF PIPERS VAN DYKE SUB NO. 2 LOT 10 EXC W 3.0 FT AND ALL OF LOTS 11 TO 14 INCL. L9 P50 (tax description)

Tax Identification Number(s): 12-13-28-483-008 (LOT 10)
More commonly known as: 7592 REPUBLIC WARREN, MI 48091

The "Right of Way Area" is a **Three (3) foot wide easement** on part of Grantor's Land. The centerline of the Right of Way Area shall be established in the as-built location of the centerline of Grantee's facilities, and shall be installed on Grantor's Land in the approximate location described as follows:

THE LEGAL DESCRIPTIONS AND EASEMENT DRAWING IS MORE PARTICULARLY DESCRIBED ON EXHIBIT "A AND B" ATTACHED HERETO AND MADE A PART HEREOF.

- 1. Purpose:** The purpose of this Right of Way is to construct, reconstruct, modify, add to, repair, replace, inspect, operate and maintain overhead and underground utility facilities which may consist of underground vaults, pipelines, poles, guys, anchors, wires, manholes, conduits, pipes, cables, transformers and accessories.
- 2. Access:** Grantee has the right of pedestrian and vehicular ingress and egress to and from the Right of Way Area over and across Grantor's Land.
- 3. Buildings or other Permanent Structures:** No buildings or other permanent structures or improvements may be constructed or placed in the Right of Way Area without Grantee's prior, written consent. Grantor agrees, at its own expense, to remove any improvement that interferes with the safe and reliable operation, maintenance and repair of Grantee's facilities upon the written demand of Grantee. If Grantor fails to comply with such demand, Grantor agrees that Grantee may remove any such improvement and bill Grantor for the cost thereof, which cost Grantor shall pay within thirty (30) days after demand therefor.
- 4. Excavation:** Pursuant to 2013 Public Act 174, MISS DIG (1-800-482-7171 or 811 in some areas) must be called before any excavation in the Right of Way Area may proceed.
- 5. Trees, Bushes, Branches, Roots, Structures and Fences:** Grantee may trim, cut down, remove or otherwise control any trees, bushes, branches and roots growing or that could grow or fall in the Right of Way Area and remove any structures, improvements, fences, buildings or landscaping in the Right of Way Area that Grantee believes could interfere with the safe and reliable construction, operation, maintenance and repair of Grantee's facilities. No landscaping, trees, plant life, structures, improvements or fences may be planted, grown or installed within 8 feet of the front door, or within 2 feet of the other sides, of transformers or switching cabinet enclosures, and Grantee shall not be responsible for any damage to, or removal of, landscaping, trees, plant life, structures, improvements and/or fences located in such areas.

6. **Restoration:** If Grantee's agents, employees, contractors, subcontractors, vehicles or equipment damage Grantor's Land while entering Grantor's Land for the purposes stated in this Right of Way, then Grantee will restore Grantor's Land as nearly as is reasonably practicable to the condition in which it existed prior to such damage. Restoration with respect to paved surfaces shall consist of asphalt cold patching of the damaged portion of any asphalted surfaces when the weather conditions suggest such use and the cement patching of the damaged portion of any cemented surfaces. Grantee shall have no liability, however, for the restoration or cost of any improvements located within the Right of Way Area, including, but not limited to, parking islands, gutters, fences or landscaping such as trees, bushes, or flowers (but not a simple lawn which, if damaged, will be patched and re-seeded by Grantee) that are damaged by Grantee in the course of constructing, reconstructing, modifying, adding to, repairing, replacing, operating or maintaining its facilities as described in paragraph 1 above.

7. **Successors:** This Right of Way runs with the land and binds and benefits Grantor's and Grantee's successors and assigns.

8. **Exemptions:** This Right of Way is exempt from transfer tax pursuant to MCL 207.505(a) and MCL 207.526(a).

9. **Governing Law:** This Right of Way shall be governed by the laws of the State of Michigan.

Grantor:

By: _____ (sign)

By: _____ (sign)

Name: _____ (print)

Name: _____ (print)

Title: _____

Title: _____

Acknowledged before me in _____ County, Michigan, on _____, 20____, by _____ the _____ of CITY OF WARREN.

Notary's Stamp _____

Notary's Signature _____

Acting in _____ County, Michigan

Drafted by and when recorded, return to: La Donna Jackson, DTE Energy, 43230 Elizabeth, Clinton Twp., MI 48036

EXHIBIT A

2/26/2024 7:50 AM



Work Order # 69747899	Work Order Description 23211 VAN DYKE AVE, WARREN	GIS-DNA 69747904	RSW 69747906	ISSD	PHI 69747919	PLC
Service Center MTC	Order #1 CENTR2440	Order #2	COB 69747926	COS	CRK	CRK
Worksite City WARREN	Worksite Vrs.	Worksite County	Worksite State	Worksite Zip	Worksite Date	Worksite Time
Name 01N 12E 28	Order #	Project Name Clark, Danielle L	734.280.0062	OK Request # 1452057	1	3/18/24
						Scale NONE

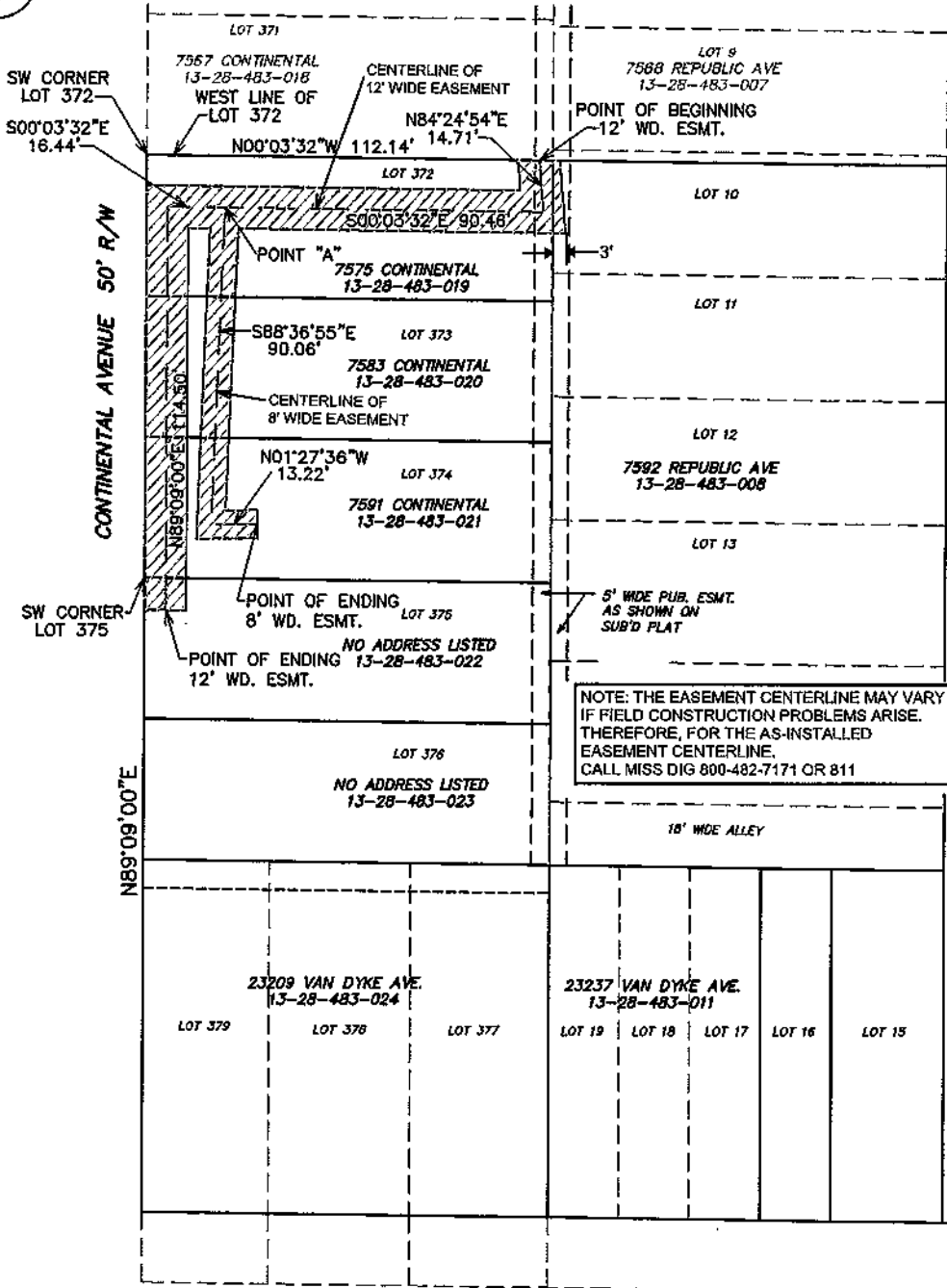

NOTE: THE EASEMENT CENTERLINE MAY VARY IF FIELD CONSTRUCTION PROBLEMS ARISE. THEREFORE, FOR THE AS-INSTALLED EASEMENT CENTERLINE, CALL MISS DIG 800-482-7171 OR 811

VAN DYKE AVENUE VARIABLE' R/W

V:\202401\20240171\F\20240171_dte_easement.dwg

Piggott, Robert

JOB NO. 20240171	HUBBELL, ROTH & CLARK, INC CONSULTING ENGINEERS SINCE 1915	555 HULET DRIVE BLOOMFIELD HILLS, MICH.	P.O. BOX 824 48303 - 0824	SHEET NO.
DATE 02/23/24		PHONE: (248) 454-6300 FAX (1st Floor): (248) 454-6312 FAX (2nd Floor): (248) 454-6399 WEB SITE: www.hrcengr.com	1	OF 2

2/26/2024 7:50 AM

EXHIBIT B

OVERALL PROPERTY DESCRIPTIONS

PARCEL 13-28-483-019
LOT 372 OF "PIPERS VAN DYKE SUB No. 2", PART OF THE SOUTHEAST QUARTER OF SECTION 28, T.1N., R.12E., CITY OF WARREN, MACOMB COUNTY, MICHIGAN AS RECORDED IN LIBER 4, PAGE 51, MACOMB COUNTY RECORDS.

PARCEL 13-28-483-020
LOT 373 OF "PIPERS VAN DYKE SUB No. 2", PART OF THE SOUTHEAST QUARTER OF SECTION 28, T.1N., R.12E., CITY OF WARREN, MACOMB COUNTY, MICHIGAN AS RECORDED IN LIBER 4, PAGE 51, MACOMB COUNTY RECORDS.

PARCEL 13-28-483-021
LOT 374 OF "PIPERS VAN DYKE SUB No. 2", PART OF THE SOUTHEAST QUARTER OF SECTION 28, T.1N., R.12E., CITY OF WARREN, MACOMB COUNTY, MICHIGAN AS RECORDED IN LIBER 4, PAGE 51, MACOMB COUNTY RECORDS.

PARCEL 13-28-483-008
LOT 10 EXCEPT THE WEST 3.0 FEET AND ALL OF LOTS 11 TO 14 INCLUSIVE OF "ROTHS SUBDIVISION OF LOT 341 OF PIPERS VAN DYKE SUB No. 2", PART OF THE SOUTHEAST QUARTER OF SECTION 28, T.1N., R.12E., CITY OF WARREN, MACOMB COUNTY, MICHIGAN AS RECORDED IN LIBER 9, PAGE 50, MACOMB COUNTY RECORDS.

DTE EASEMENT DESCRIPTION

A 12' WIDE EASEMENT DESCRIBED AS BEGINNING AT A POINT ON THE WEST LINE OF LOT 372, WHICH IS NORTH 00 DEGREES 03 MINUTES 32 SECONDS WEST 112.14 FEET FROM THE SOUTHWEST CORNER OF SAID LOT 372 OF "PIPERS VAN DYKE SUB No. 2", PART OF THE SOUTHEAST QUARTER OF SECTION 28, T.1N., R.12E., CITY OF WARREN, MACOMB COUNTY, MICHIGAN AS RECORDED IN LIBER 4, PAGE 51, MACOMB COUNTY RECORDS; THENCE NORTH 84 DEGREES 24 MINUTES 54 SECONDS EAST 14.71 FEET; THENCE SOUTH 00 DEGREES 03 MINUTES 32 SECONDS EAST 90.46 FEET ALONG A LINE WHICH IS PARALLEL TO THE WEST LINE OF SAID LOT 372 TO POINT "A"; THENCE CONTINUING SOUTH 00 DEGREES 03 MINUTES 32 SECONDS EAST 16.44 FEET; THENCE NORTH 89 DEGREES 09 MINUTES 00 SECONDS EAST 114.50 FEET ALONG A LINE WHICH IS 6 FEET NORTH OF AND PARALLEL TO THE NORTH LINE OF CONTINENTAL AVENUE (50' RIGHT OF WAY) TO THE POINT OF ENDING;

ALSO AN 8' WIDE EASEMENT DESCRIBED AS BEGINNING AT SAID POINT "A"; THENCE SOUTH 88 DEGREES 36 MINUTES 55 SECONDS EAST 90.06 FEET; THENCE NORTH 01 DEGREES 27 MINUTES 36 SECONDS WEST 13.22 FEET TO THE POINT OF ENDING.

CONTAINS 3,609 SF

V:\202401\20240171\F\20240171_dte_easement.dwg

Piggott, Robert

JOB NO. 20240171	 HUBBELL, ROTH & CLARK, INC CONSULTING ENGINEERS SINCE 1915	555 HULET DRIVE BLOOMFIELD HILLS, MICH.	P.O. BOX 824 48303 - 0824	SHEET NO.
DATE 02/23/24		PHONE: (248) 454-6300 FAX (1st Floor): (248) 454-6312 FAX (2nd Floor): (248) 454-6359 WEB SITE: www.hrcenr.com	2	OF 2

End of Item 12

CITY OF WARREN
Office of the Council Secretary

Item 4m/14l

INTER-OFFICE COMMUNICATION

DATE: May 14, 2024

TO: Lorie Barnwell, Treasurer and David Muzzarelli, Public Service Director

SUBJECT: Request of the City Treasurer and Public Service Director to waive the bidding process and authorize one (1) year of online service and support to BS&A Software, in the annual amount of \$48,921.00. CONSIDERATION AND ADOPTION OF A RESOLUTION.

At a Regular meeting of the City Council held Tuesday, May 14, 2024, Council made the formal motion to move this item to the main agenda as item 14l, then made the formal motion to table the above listed item approve to get clarification on why the contract would only be for one (1) year.

Trusting this information to be of value.



Mindy Moore
Council Secretary

cc: Attorney
Clerk
Mayor



CITY CONTROLLER'S OFFICE

ONE CITY SQUARE, SUITE 425

WARREN, MI 48093-5289

(586) 574-4600

FAX (58) 574-4614

www.cityofwarren.org

DATE: MAY 6, 2024
TO: MINDY MOORE, SECRETARY, WARREN CITY COUNCIL
SUBJECT: SOL-W-1222; AWARD FOR BS&A ONLINE SERVICE AND SUPPORT

The Purchasing Department, in conjunction with the City Treasurer and Public Service Director recommends that City Council waive the bidding procedure and authorize one year of online service and support beginning August 1, 2024 with BS&A Software, 14965 Abbey Lane, Bath, MI 48808 in the annual amount of \$48,921.00.

BS&A is the software vendor that provides the City with Assessing Software, Treasury Department Software and Building Division Software. In addition, a multitude of Michigan communities, including Macomb County, utilize this system. BS&A provides online service and support. This service allows city customers to view property information on a website. Homeowners, business owners, realtors, appraisers, lenders, title companies, contractors and others now have access to information 24/7.

City of Warren residents that want to access information on their own property or other city properties can do so for free. This allows them to access the purchase prices, assessed values, taxable values, and other descriptive property information.

This proposal represents a win-win for residents, business, and city government. Better access to public records, 24 hours a day, makes our customers happy. Staff will have fewer phone calls, allowing them to concentrate on other areas of public service to assist more residents and businesses in other areas. This web service is user friendly and cost effective. In addition, the citizens benefit greatly from this technological advancement made by the city.

The Information Services Division has indicated that having BS&A provide this service is more economical and practical than having such a system developed internally. They indicate that changes in the Equalizer Program are integrated into the internet program automatically.

Funding for this purchase is provided in the following budget accounts:

Assessing Department Account:	101-1209-80106	\$ 10,494.36
Treasurer's Office Account:	101-1253-80100	\$ 10,494.36
Building Division Account:	101-1371-80106	\$ 24,822.84
Rental Division Account:	230-9230-80100	\$ <u>3,109.44</u>
TOTAL:		\$ <u>48,921.00</u>

Respectfully Submitted,



Craig Treppa
Purchasing Agent



Dave Muzzarelli
Public Service Director

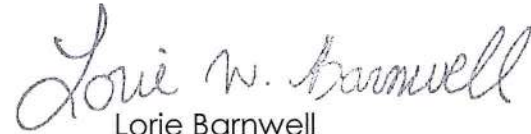

Lorie Barnwell
City Treasurer

Approved By:	Signature	Date
Budget Director:		5/6/2024
Controller:		5/6/2024
MAYOR:		5/7/2024

RESOLUTION

Document No: SOL-W-1222

Product or Service: Online Service and Support

Requesting Department: Assessing, Treasurer, Building & Rental

At a Regular Meeting of the City Council of the City of Warren, County of Macomb, Michigan, held on _____, 2024 at 7 p.m. Local Time, in the Council Chamber at the Warren Community Center Auditorium, 5460 Arden, Warren, Michigan.

PRESENT: Councilmembers: _____

ABSENT: Councilmembers: _____

The following preamble and resolution were offered by Councilmember

_____ and supported by Councilmember _____.

Upon performing a diligent inquiry, the *City Treasurer and Public Service Director* have determined that it is necessary in the interests of the City, to acquire online service and support from a sole source. Justification for a sole source provider include the ability of City customers to view property information such as purchase prices, assessed values, taxable values, and other descriptive property information on a website 24 hours a day, seven days a week.

The BS&A Software, 14965 Abbey Lane, Bath, MI 48808 has been selected as the sole source provider for online service and support.

The Purchasing Agent has conducted a review and concurs with the sole procurement.

Funds are available in the following accounts:

Assessing Department Account:	101-1209-80106	\$ 10,494.36
Treasurer's Office Account:	101-1253-80100	\$ 10,494.36
Building Division Account:	101-1371-80106	\$ 24,822.84
Rental Division Account:	230-9230-80100	\$ 3,109.44
TOTAL:		<u>\$ 48,921.00</u>

IT IS RESOLVED, that the sole source purchase though BS&A Software is hereby accepted by City Council for a one-year period, commencing on August 1, 2024, in an amount of \$48,921.00.

IT IS FURTHER RESOLVED, that the Purchasing Agent and/or Mayor and City Clerk are authorized to execute any such documents that are necessary for this approval consistent with the terms of the:

- Contract
- Resolution

and in such form that meets with the satisfaction of the City Attorney if review is required.

AYES: Councilmembers: _____

NAYS: Councilmembers: _____

RESOLUTION DECLARED ADOPTED this _____ day of _____, 2024.

Mindy Moore
Secretary of the Council



CITY CONTROLLER'S OFFICE

ONE CITY SQUARE, SUITE 425
WARREN, MI 48093-5289
(586) 574-4600
FAX (586) 574-4614
www.cityofwarren.org

May 20, 2024

Ms. Mindy Moore
Council Secretary
City of Warren, Michigan

Re: Request for an Increase in Budgeted Revenues and Appropriations – 37th
District Court, Legal, City Retirement, P&F Retirement and Street lighting

Dear Council Secretary Moore:

The Budget Director with the concurrence of the various department officials has indicated a need to this Council for a transfer of funds between line items in the amount of \$101,625.00 and an additional appropriation of funds in the amount of \$30,000.00 to provide sufficient funding in the several accounts within the General Fund Budget for the balance of the 2024 fiscal year. Additional funds are necessary to cover increased office supply costs, contractual services fees, street lighting costs and contractual obligations.

A copy of an amending budget resolution is attached for Council action.

Respectfully,

A handwritten signature in black ink, appearing to read "Kristina K Battle".

Kristina K Battle
Budget Director

Approved: _____

A handwritten signature in blue ink, appearing to read "Lori M. Stone".
Lori M. Stone, Mayor

cc: Richard Fox
Annette Gattari-Ross
Mary Michaels
Renee Barrick
Jennifer Essenmacher
David Muzzarelli

Re: Court office supplies over budget 1136 72700 and 80100

Annette Gattari-Ross <agattariross@37thdistrictcourt.org>

Mon 5/13/2024 3:23 PM

To:Kris Battle <kbattle@cityofwarren.org>

Cc:Katelynn Best <kbest@37thdistrictcourt.org>

Kris,

Thanks for bringing this to our attention.

As to Office Supplies (101-1136-72700) please add \$15,000 from Permanent Employees (101-1136-70600).

As to Contractual Services (101-1136-80100) please add \$8500 from Permanent Employees (101-1136-70600).

In April of each year, I will check our balances to make sure we have sufficient funds in each account.

Respectfully,



Annette Gattari-Ross
Court Administrator/Magistrate
37th District Court (Warren/Center Line)
P: (586) 574-4928
F: (586) 582-4313

From: Kris Battle <kbattle@cityofwarren.org>
Sent: Thursday, May 9, 2024 7:56 PM
To: Annette Gattari-Ross <agattariross@37thdistrictcourt.org>
Cc: Katelynn Best <kbest@37thdistrictcourt.org>
Subject: Court office supplies over budget 1136 72700 and 80100

Hi - Breakdown of 1136-72700 in BSA:

110,000.00	FY24 Budget
91,938.61	FY24 Expenditures to date
20,482.69	FY24 Open/Encumbered Pos
(2,421.30)	GL Balance
(1,500.00)	Change orders not approved
(3,921.30)	True Balance/shortage@ 5/9/24

Funds can not be transferred from the Building Fund because it is a separate fund.

1237

FY24 Budget Amendment Request

Renee Barrick <rbarrick@cityofwarren.org>

Wed 5/15/2024 1:18 PM

To: Kris Battle <kbattle@cityofwarren.org>

Hi Kris,

Can you move \$3,000 from our Part-time line item to the overtime line item in the FY24 budget?

Thank you,

Renee Barrick

Administrator
General Employees Retirement Office
City of Warren
One City Square, Suite 415
Warren, MI 48093
Phone: 586-574-4634
Email: rbarrick@cityofwarren.org

RESOLUTION AMENDING GENERAL APPROPRIATIONS
FOR FISCAL 2024 BUDGET

A _____ Meeting of the City Council of the City of Warren,
County of Macomb, Michigan held _____, 2024, at 7:00 o'clock p.m.
Eastern Standard Time in the Council Chambers at the Warren Community Center.

PRESENT: Council Members _____

ABSENT: Council Members _____

The following preamble and resolution were offered by Council Member _____
and supported by Council Member _____.

WHEREAS, the budget for fiscal year July 1, 2023 to June 30, 2024 was adopted by
Council on May 9, 2023, and

WHEREAS, the Budget Director with the concurrence of the various department
officials has indicated a need to this Council for a transfer of funds between line items in the
amount of \$101,625.00 and an additional appropriation of funds in the amount of \$30,000.00 to
provide sufficient funding in the several accounts within the General Fund Budget for the balance
of the 2024 fiscal year. Additional funds are necessary to cover increased office supply costs,
contractual services fees, street lighting costs and contractual obligations,

NOW, THEREFORE, BE IT RESOLVED, that the City Council by amending the
original General Appropriation Resolution for Fiscal 2024 Budget, approves the additional
appropriation of funds to the following budget line items in the General Fund Budget in the
amount of \$131,625.00.

<u>Account Number</u>	<u>Account Title</u>	<u>Amount</u>
<u>Transfer to:</u>		
101-1136-72700	Office Supplies	\$ 15,000.00
101-1136-80100	Contractual Services	8,500.00
101-1210-70300	Appointed Official	11,500.00
101-1210-71303	Clothing Allowance	250.00
101-1210-72101	Sick Redemption	2,000.00
101-1237-70900	Overtime	3,000.00
101-1237-71905	Health Savings	250.00
101-1237-72201	Defined Contribution	250.00
101-1238-71500	Social Security	1,200.00
101-1238-71900	Employee Insurances	7,000.00
101-1238-71905	Health Savings	325.00
101-1238-72201	Defined Contribution	2,350.00
101-1238-96910	Medicare Reimbursement	50,000.00
101-1448-92600	Street Lighting	<u>30,000.00</u>
		\$ 131,625.00

<u>Transfer From:</u>		
101-1136-70600	Permanent Employees	\$ 23,500.00
101-1210-70601	Assistant Attorneys	13,750.00
101-1237-70700	Temporary Employees	3,500.00
101-1238-70700	Temporary Employees	10,875.00
101-1238-96905	Veba Reimbursement	50,000.00
101-0000-39601	General Fund Contingency	<u>30,000.00</u>
		\$ 131,625.00

BE IT FURTHER RESOLVED that the City Council hereby revises the appropriations for the General Fund Budget for fiscal 2024 in the amount of \$131,625.00.

AYES: Council Members _____

NAYS: Council Members _____

RESOLUTION DECLARED ADOPTED this ____ day of _____, 2024.

MINDY MOORE
Secretary of the Council

CERTIFICATION

STATE OF MICHIGAN)

) SS

COUNTY OF MACOMB)

I, SONJA BUFFA, duly elected City Clerk for the City of Warren, Macomb County, Michigan, hereby certify that the foregoing is a true and correct copy of the resolution adopted by the Council at its meeting held on _____.

SONJA BUFFA
City Clerk



CITY CONTROLLER'S OFFICE

ONE CITY SQUARE, SUITE 425
WARREN, MI 48093-5289
(586) 574-4600
FAX (586) 574-4614
www.cityofwarren.org

May 20, 2024

Ms. Mindy Moore
Council Secretary
City of Warren, Michigan

Re: Request for an Increase in Budgeted Revenues and Appropriations – 37th
District Court

Dear Council Secretary Moore:

In her correspondence dated May 10, 2024, the 37th District Court Administrator requests an increase in budgeted revenues and appropriations in the amount of \$71,176.00 to account for the receipt of a Michigan State Court Administrative Grant; Clean Slate Overtime reimbursement.

A copy of an amending budget resolution is attached for Council action.

Respectfully,

Kristina K Battle
Budget Director

Approved: _____



Lori M. Stone, Mayor

cc: Richard Fox
Annette Gattari-Ross
Brandon Roy

Clean Slate Overtime/Temporary Staffing Reimbursement----

Kris Battle <kbattle@cityofwarren.org>

Fri 5/10/2024 11:10 AM

To: Annette Gattari-Ross <agattariross@37thdistrictcourt.org>

Cc: Brandon Roy <broy@warrenpd.org>

 1 attachments (1 MB)

20240510102653939.pdf;

Annette and Brandon

Attached is a budget amendment for the 5/28/24 agenda.

Best to treat this as a grant. Just like the CESF grant, all overtime worked for this grant will need to be journalled to the newly created Clean Slate OT line item (1136-74007) from the perspective department's OT accounts (1136-70900 or 1301-70902) for existing personnel who work OT for this purpose.

Any funds not spent in FY24 will be re-appropriated to FY25.

Kris Battle, Budget Director

From: Annette Gattari-Ross <agattariross@37thdistrictcourt.org>

Sent: Friday, May 10, 2024 8:25 AM

To: Kris Battle <kbattle@cityofwarren.org>

Cc: Brandon Roy <broy@warrenpd.org>

Subject: Re: Revisit Clean Slate Overtime/Temporary Staffing Reimbursement----

Kris,

Sorry, I used the grant word loosely. We never applied, the fund was just awarded, so I would say it is a reimbursement grant.

You are correct that there has been no overtime utilized as of this date, but we are going to utilize it now, especially for the police department. Our data migration is impacting us, but we are working on a work around.

So, I suppose we need to request a budget amendment for FY24 for police for \$15,500.

Reimbursement for police for FY25 July 1, 2024 through August 30, 2024 is estimated at \$24,500.

The court estimates it will use overtime in the amount of \$25K for FY25.

What do I need to do from here?

Respectfully,



Annette Gattari-Ross
Court Administrator/Magistrate
37th District Court (Warren/Center Line)
P: (586) 574-4928
F: (586) 582-4313

From: Kris Battle <kbattle@cityofwarren.org>
Sent: Thursday, May 9, 2024 8:18 PM
To: Annette Gattari-Ross <agattariross@37thdistrictcourt.org>
Cc: Brandon Roy <broy@warrenpd.org>
Subject: Re: Revisit Clean Slate Overtime/Temporary Staffing Reimbursement----

Annette and Brandon.

Previously I was under the impression this was a reimbursement and not a grant and yes did do a budget amendment to the Court's budget in FY23 for \$15,000 and FY24 for \$25,000. To my knowledge, no overtime, requests for reimbursement or monies received for reimbursement have occurred thus far.

If this is a grant, then I would need the grant documentation to prepare correspondence to Council and create specific account numbers. My cut off for the 5/28/24 agenda is 5/17/24. Once approved by Council, journals for the specific overtime would need to be done just like the CESF grant. Also, all amounts reported on the grant would need my office's concurrence prior to requesting reimbursement.

Kris Battle, Budget Director

City of Warren Controller's Office
One City Square, Suite 425

Warren, MI 48093-5288

Phone: 586-574-4593

Fax: 586-574-4614

Email: kbattle@cityofwarren.org



CONFIDENTIALITY NOTICE:

The contents of this email message and any attachments are intended solely for the addressee(s) and may contain confidential and/or privileged information and may be legally protected from disclosure. If you are not the intended recipient of this message or their agent, or if this message has been addressed to you in error, please immediately alert the sender by reply email and then delete this message and any attachments. If you are not the intended recipient, you are hereby notified that any use, dissemination, copying, or storage of this message or its attachments is strictly prohibited.

From: Annette Gattari-Ross <agattariross@37thdistrictcourt.org>
Sent: Thursday, May 9, 2024 5:10 PM
To: Kris Battle <kbattle@cityofwarren.org>
Cc: Brandon Roy <broy@warrenpd.org>
Subject: Re: Revisit Clean Slate Overtime/Temporary Staffing Reimbursement----

Kris,

What if anything do we need to prepare for the May 28, 2024 council meeting to start using the grant money that is available until at least August 30, 2024.

Based upon your email 7/5/24 email, I believe you did a budget amendment for the court related to this.

Per my communications with Brandon, grant funds needed to pay for police overtime for FY24 is 15,500. Grant fund need for July 1, 2024 through August 30, 2024 is \$24,500.

The court estimates it will use overtime in the amount of \$25K for FY25.

This will be paid by SCAO through this process.



Michigan Supreme Court

State Court Administrative Office
Michigan Hall of Justice
P.O. Box 30048
Lansing, Michigan 48909
517-373-0128

Thomas P. Boyd
State Court Administrator

MEMORANDUM

DATE: May 12, 2023

TO: Circuit, District, Municipal, and Probate Judges, Court Administrators, and Probate Registers

FROM: Thomas P. Boyd, State Court Administrator

SUBJECT: Automatic Clean Slate Overtime/Temporary Staffing Reimbursement

Thank you for your continued efforts to respond to public record requests during the initial update period of Automatic Clean Slate implementation. Access to accurate public records is a cornerstone of transparency and sustained public trust in the judiciary.

Courts have recently reported delays in processing records requests as a result of clean slate implementation. Under the Michigan Court Rules, each trial court has their own Local Administrative Order (LAO) to govern Access to Records. These LAOs often suggest that records will be made available within a "reasonable amount of time." While some delays are understandable due to the circumstances, the State Court Administrative Office has previously understood a reasonable amount of time as a matter of days, not weeks, and has not understood this language to allow a complete suspension of access.

To facilitate timely processing of records requests with the increased demand and workload due to the implementation of Automatic Clean Slate, courts have reported increased staffing needs. The State Court Administrative Office (SCAO) has listened and heard your concerns.

In an effort to alleviate some of the stress on court staff and internal resources, we have allocated additional funding for trial court Automatic Clean Slate implementation. With these additional funds, courts are able to request reimbursement for overtime or temporary staffing to timely respond to public record requests, removal of bench warrants, and other implementation related work. Each court will have a cap on the funding available for this opportunity, calculated using a universal base amount plus a percentage of total criminal case filings in each court, up to a maximum allocation cap.

The SCAO has developed a process to facilitate the submission of invoices, supporting documentation, progress reports, approvals, and reimbursements for Automatic Clean Slate implementation. Overtime/temp reimbursement will follow the same process, as outlined below.

Automatic Clean Slate Overtime/Temporary Staffing Reimbursement Process

- All invoices must contain a description of the work and the costs requested for overtime or temporary staffing and should indicate the project code: OVT. The invoice template is attached as Appendix B.
- Invoices must be sent monthly to CleanSlate.Billing@courts.mi.gov.
- In addition to the invoice, courts must also provide SCAO with supporting documentation including an itemization of actual hours worked. The Excel template is attached as Appendix C.
- Reimbursement will be provided based on the number of actual hours worked on the engagement within the assigned cap for each trial court.
- A confirmation email will be sent by SCAO to the court indicating approval of the reimbursement, or notifying the court of any items that were not approved as reimbursable expenses for this project.
- Once approved, the SCAO Finance Division will process the invoice and remit payment to the court within (30) days.
- If not already registered, the court is required to register to receive payments by EFT at Sigma Vendor Self Service (VSS) (<http://www.Michigan.gov/SIGMAVSS>). Registration instructions are attached as Exhibit D.
- This funding may be utilized for expenditures incurred for overtime and/or temporary workers required to meet the challenges presented by Automatic Clean Slate implementation. Reimbursement may be sought for overtime and/or temporary workers incurred from April 11, 2023, through July 31, 2023. Reimbursement requests may not exceed and will not be reimbursed in excess of the cap provided for each trial court.
- Amounts requested for this project should be reported along with other cost estimates in the court's monthly progress report but should be listed on a separate line and include the OVT code. The process for submitting the progress report is as follows: Beginning thirty (30) days after the court has started performing services, and every thirty (30) days thereafter until project completion, the court must provide SCAO with a report as to the court's progress toward completion of services. The report must include: 1) the date range for the 30-day period of services covered in the report (the reporting period); 2) the estimated percentage of progress made toward completion of the Services during the reporting period (for example, "The Services are 10% complete, with 90% of the Services yet to be provided." etc.); and 3) the estimated percentage of funds expended for Services as it relates to the overall estimated budgeted amount during the reporting period. These progress reports shall also be sent to: CleanSlate.Billing@courts.mi.gov.

Automatic Clean Slate Overtime/Temporary Staffing Reimbursement Allocation Caps

Region	County	Court Type	Court	Allocation Caps
5	Kent	District	D63	\$38,976
4	Keweenaw	Circuit	C12	\$5,020
4	Keweenaw	District	D97	\$5,287
3	Lake	Circuit	C27	\$5,551
3	Lake	District	D78	\$10,307
6	Lapeer	Circuit	C40	\$7,271
6	Lapeer	District	D71A	\$18,539
4	Leelanau	Circuit	C13	\$5,191
4	Leelanau	District	D86	\$7,124
2	Lenawee	Circuit	C39	\$8,110
2	Lenawee	District	D02A	\$28,292
2	Livingston	Circuit	C44	\$9,137
2	Livingston	District	D53	\$28,277
4	Luce	Circuit	C11	\$5,351
4	Luce	District	D92	\$6,849
4	Mackinac	Circuit	C11	\$5,586
4	Mackinac	District	D92	\$9,135
6	Macomb	Circuit	C16	\$29,949
6	Macomb	District	D37	\$71,176
6	Macomb	District	D38	\$29,948
6	Macomb	District	D39	\$34,541
6	Macomb	District	D40	\$46,931
6	Macomb	District	D41A	\$52,863
6	Macomb	District	D41B	\$35,162
6	Macomb	District	D42-1	\$12,086
6	Macomb	District	D42-2	\$20,638
3	Manistee	Circuit	C19	\$5,704
3	Manistee	District	D85	\$11,614
4	Marquette	Circuit	C25	\$7,683
4	Marquette	District	D96	\$19,533
3	Mason	Circuit	C51	\$6,036
3	Mason	District	D79	\$12,583
3	Mecosta	Circuit	C49	\$6,827
3	Mecosta	District	D77	\$15,520
4	Menominee	Circuit	C41	\$5,639
4	Menominee	District	D95A	\$12,053
3	Midland	Circuit	C42	\$6,884
3	Midland	District	D75	\$16,715
4	Missaukee	Circuit	C28	\$5,546
4	Missaukee	District	D84	\$8,159
2	Monroe	Circuit	C38	\$9,480
2	Monroe	District	D01	\$44,484
3	Montcalm	Circuit	C08	\$6,826
3	Montcalm	District	D64B	\$15,579
4	Montmorency	Circuit	C26	\$5,242



RESOLUTION AMENDING GENERAL REVENUES AND APPROPRIATIONS
FOR FISCAL 2024 BUDGET

A _____ Meeting of the City Council of the City of Warren,
County of Macomb, Michigan held _____, 2024, at 7:00 o'clock p.m.
Eastern Standard Time in the Council Chambers at the Warren Community Center.

PRESENT: Council Members _____

ABSENT: Council Members _____

The following preamble and resolution were offered by Council Member _____,
and supported by Council Member _____.

WHEREAS, the budget for fiscal year July 1, 2023 to June 30, 2024 was adopted by
Council on May 9, 2023, and

WHEREAS, the Court Administrator has indicated a need to this Council for an
increase in budgeted revenues and appropriations in the amount of \$71,176.00 to account for
the receipt of a Clean Slate overtime reimbursement grant from Michigan's State Court
Administrative Office (SCAO),

NOW, THEREFORE, BE IT RESOLVED, that the City Council by amending the
original General Appropriation Resolution for the Fiscal 2024 Budget, approves the additional
revenues and appropriation of funds to the following budget line items in the General Fund
Budget for fiscal 2024 in the amount of \$71,176.00.

<u>Account Number</u>	<u>Account Title</u>	<u>Amount</u>
<u>Increase Revenues:</u>		
101-0080-54750	SCAO Clean Slate OT	\$ 71,176.00
<u>Increase Appropriations:</u>		
101-1136-74007	SCAO Clean Slate OT Expense	\$ 71,176.00

BE IT FURTHER RESOLVED, that the City Council hereby revises the estimated revenues and appropriations for the General Fund Budget for fiscal 2024 in the amount of \$71,176.00.

AYES: Council Members _____

NAYS: Council Members _____

RESOLUTION DECLARED ADOPTED this _____ day of _____, 2024.

MINDY MOORE
Secretary of the Council

CERTIFICATION

STATE OF MICHIGAN)

) SS

COUNTY OF MACOMB)

I, SONJA BUFFA, duly elected City Clerk for the City of Warren, Macomb County, Michigan, hereby certify that the foregoing is a true and correct copy of the resolution adopted by the Council at its meeting held on _____.

SONJA BUFFA
City Clerk



CITY CONTROLLER'S OFFICE

ONE CITY SQUARE, SUITE 425
WARREN, MI 48093-5289
(586) 574-4600
FAX (586) 574-4614
www.cityofwarren.org

May 20, 2024

Ms. Mindy Moore
Council Secretary
City of Warren, Michigan

Re: Request for an Increase in Budgeted Revenues and Appropriations – Building Inspections, Public Service and Property Maintenance.

Dear Council Secretary Moore:

The Budget Director with the concurrence of the various department officials has indicated a need to this Council for a transfer of funds between line items in the amount of \$30,600.00 to provide sufficient funding in the several accounts within the General Fund Budget for the balance of the 2024 fiscal year. Additional funds are necessary to cover increased utility costs and contractual obligations.

A copy of an amending budget resolution is attached for Council action.

Respectfully,

A handwritten signature in black ink, appearing to read "Kristina K Battle".

Kristina K Battle
Budget Director

Approved:

A handwritten signature in blue ink, appearing to read "Lori M. Stone".

Lori M. Stone, Mayor

cc: Richard Fox
David Muzzarelli

**RESOLUTION AMENDING GENERAL APPROPRIATIONS
FOR FISCAL 2024 BUDGET**

A _____ Meeting of the City Council of the City of Warren,
County of Macomb, Michigan held _____, 2024, at 7:00 o'clock p.m.
Eastern Standard Time in the Council Chambers at the Warren Community Center.

PRESENT: Council Members _____

ABSENT: Council Members _____

The following preamble and resolution were offered by Council Member _____,
and supported by Council Member _____.

WHEREAS, the budget for fiscal year July 1, 2023 to June 30, 2024 was adopted by
Council on May 9, 2023, and

WHEREAS, the Budget Director with the concurrence of the various department
officials has indicated a need to this Council for a transfer of funds between line items in the
amount of \$30,600.00 to provide sufficient funding in the several accounts within the General
Fund Budget for the balance of the 2024 fiscal year. Additional funds are necessary to cover
increased utility costs and contractual obligations,

NOW, THEREFORE, BE IT RESOLVED, that the City Council by amending the
original General Appropriation Resolution for Fiscal 2024 Budget, approves the additional
appropriation of funds to the following budget line items in the General Fund Budget in the
amount of \$30,600.00.

<u>Account Number</u>	<u>Account Title</u>	<u>Amount</u>
<u>Transfer to:</u>		
101-1371-70909	Overtime	\$15,000.00
101-1371-71906	Supplemental Life Insurance	900.00
101-1421-70300	Appointed Official	3,100.00
101-1421-71906	Supplemental Life Insurance	100.00
101-1422-70700	Temporary Employees	6,500.00
101-1422-92000	Public Utilities	<u>5,000.00</u>
		\$ 30,600.00
<u>Transfer From:</u>		
101-1371-70602	Clerical	\$ 15,900.00
101-1421-70600	Permanent Employees	3,200.00
101-1422-70705	Temporary Inspection	<u>11,500.00</u>
		\$ 30,600.00

BE IT FURTHER RESOLVED that the City Council hereby revises the appropriations for the General Fund Budget for fiscal 2024 in the amount of \$30,600.00.

AYES: Council Members _____

NAYS: Council Members _____

RESOLUTION DECLARED ADOPTED this ____ day of _____, 2024.

MINDY MOORE
Secretary of the Council

CERTIFICATION

STATE OF MICHIGAN)

) SS

COUNTY OF MACOMB)

I, SONJA BUFFA, duly elected City Clerk for the City of Warren, Macomb County, Michigan, hereby certify that the foregoing is a true and correct copy of the resolution adopted by the Council at its meeting held on _____.

SONJA BUFFA
City Clerk



CITY CONTROLLER'S OFFICE

ONE CITY SQUARE, SUITE 425
WARREN, MI 48093-5289
(586) 574-4600
FAX (586) 574-4614
www.cityofwarren.org

May 20, 2024

Ms. Mindy Moore
Council Secretary
City of Warren, Michigan

Re: Request for an Increase in Budgeted Revenues and Appropriations – Police

Dear Council Secretary Moore:

In correspondence dated May 10, 2024, the Police Department has indicated a need to this Council for an increase in budgeted revenues and appropriations in the amount of \$10,000.00. These funds are being requested to account for the receipt of additional PA 302 Training funds received from the State of Michigan.

A copy of an amending budget resolution is attached for Council action.

Respectfully,

A handwritten signature in black ink, appearing to read "Kristina K Battle".

Kristina K Battle
Budget Director

Approved: _____

A handwritten signature in blue ink, appearing to read "Lori M. Stone".

Lori M. Stone, Mayor

cc: Richard Fox
Cpt. Wolfe
Sgt. Ptaszek

Budge Amendment Request

Mark Ptaszek <mptaszek@warrenpd.org>

Fri 5/10/2024 12:52 PM

To:Kris Battle <kbattle@cityofwarren.org>

Cc:James Wolfe <jwolfe@warrenpd.org>

Kris Battle,

With our conversation and Fund analysis in account #262-9262-86400, "302 Funds" We respectfully request an additional \$10,000 Budget amendment for the account to satisfy the purchases expected for the remainder of the fiscal year 23-24.

Thank you for your assistance in this matter!

Respectfully,

Sergeant Mark Ptaszek #501

Warren Police Department

Administration

29900 Civic Center Drive

Warren, Michigan 48093

586-574-4768 (desk phone)



WARREN POLICE DEPARTMENT
29900 CIVIC CENTER BLVD.
WARREN, MI 48093
(586) 574-4700
FAX (586) 574-4862 www.cityofwarren.org

May 10, 2024

Craig Treppa/Kris Battle
Warren City Hall
Purchasing/Controller's office
One City Square
Warren, Michigan 48093

RE: PURCHASE INFORMATION REGARDING BUILDING SUPPLIES AND EQUIPMENT (UTILIZING 302 FUNDS)

Dear Mr. Treppa/Mrs. Battle,

The Warren Police Department Professional Standards Bureau is required to equip our sworn members with the training and knowledge to handle every-day duties. The example of these duties range from report writing to use-of-force situations. The Professional Standards Bureau is also required to ensure our members are in compliance with MCOLES (Michigan Commission on Law Enforcement Standards) regulations.

MCOLES requires sworn members of the police department to qualify with their firearms every year. MCOLES has now required (new in 2024) members to endure force-on-force training. This means the members of the department will be required to be trained/exposed to real-life deadly force situations such as a "shoot" and "don't shoot" situations, among other scenarios. This type of training uses simmunitions (non lethal paint pellets).

The best way for Members to experience the various force-on-force scenarios would be to expose them to what is described as a "Modular training house". This structure is a fluid configuration that can be built and de-constructed to apply to various situations our Members may face while making contact with subjects. It can be used to mimic actual residential, business, and commercial structures, which could help our Members/SRT Officers hone their skills during similar encounters.

Our Professional Standards Bureau superiors have researched a modular training house that would comply with MCOLES standards and would also suit our needs as a Police Department. A company known as "Simtek" was discovered to have the products that were needed to satisfy the requirements, but the pricing was between \$25,000-\$30,000.

In researching further, it was determined that our Training staff would be able to gather the equipment and items needed to meet the standards and requirements to train our Members as described. The amount needed for the items would not exceed \$6,500.00.

The items to be purchased for this apparatus is approved utilizing the 302 Training Funds.

Specifically, the Businesses that would be used for the purchases:

Groesbeck Lumber and Supply at 23155 Groesbeck in Warren, Michigan.
Lumber and fasteners would amount to \$4,414.04

Metal Mart U.S.A. at 31164 Dequindre in Warren, Michigan.
Metal brackets would amount to \$1,915.81.

This amount is not only in the best interest of the City of Warren, but also exhibits fiscal responsibility while supporting companies invested in this city.

Respectfully,

Mark Ptaszek, Staff Sergeant
Administrative Services Bureau

Paul Houtos, Captain
Professional Standards Bureau

RESOLUTION AMENDING GENERAL REVENUES AND APPROPRIATIONS
FOR FISCAL 2024 BUDGET

A _____ Meeting of the City Council of the City of Warren, County of Macomb, Michigan held _____, 2024, at 7:00 o'clock p.m. Eastern Standard Time in the Council Chambers at the Warren Community Center.

PRESENT: Council Members _____

ABSENT: Council Members _____

The following preamble and resolution were offered by Council Member _____ and supported by Council Member _____.

WHEREAS, the budget for fiscal year July 1, 2023 to June 30, 2024 was adopted by Council on May 9, 2023, and

WHEREAS, the Police Department has indicated a need to this Council for an increase in budgeted revenues and appropriations in the amount of \$10,000.00 to account for the receipt of additional PA 302 Training funds received from the State of Michigan,

NOW, THEREFORE, BE IT RESOLVED, that the City Council by amending the original General Appropriation Resolution for the Fiscal 2024 Budget, approves the additional revenues and appropriation of funds to the following budget line items in the Police Training Fund Budget for fiscal 2024 in the amount of \$10,000.00.

<u>Account Number</u>	<u>Account Title</u>	<u>Amount</u>
<u>Increase Revenues:</u> 262-0080-54400	Police Training	\$ 10,000
<u>Increase Appropriations:</u> 262-9262-86400	Conferences & Workshops	\$ 10,000

BE IT FURTHER RESOLVED, that the City Council hereby revises the estimated revenues and appropriations for the Police Training Special Revenue Fund Budget for fiscal 2024 in the amount of \$10,000.00.

AYES: Council Members _____

NAYS: Council Members _____

RESOLUTION DECLARED ADOPTED this ____ day of _____, 2024.

MINDY MOORE
Secretary of the Council

CERTIFICATION

STATE OF MICHIGAN)

) SS

COUNTY OF MACOMB)

I, SONJA BUFFA, duly elected City Clerk for the City of Warren, Macomb County, Michigan, hereby certify that the foregoing is a true and correct copy of the resolution adopted by the Council at its meeting held on_____.

SONJA BUFFA
City Clerk



CITY CONTROLLER'S OFFICE
 ONE CITY SQUARE, SUITE 425
 WARREN, MI 48093-5289
 (586) 574-4600
 FAX (586) 574-4614
 www.cityofwarren.org

DATE: MAY 15, 2024
 TO: MINDY MOORE, SECRETARY, WARREN CITY COUNCIL
 SUBJECT: RECOMMENDATION TO APPROVE CHANGE ORDER FOR THE BS&A CLOUD MIGRATION PROJECT; SOL-W-1107

The Purchasing Division concurs with the I.S. Department and recommends that City Council approve a change order request for the BS&A Cloud Migration Project, from a total amount of \$855,465.00 to a total amount of \$859,505.00 (an increase of \$4,040.00) to the sole source provider, BS&A Software, 14965 Abbey Lane, Bath, MI 48808.

This increase of \$4,040.00 that is shown in the attached change order is due to additional hours needed to address the Assessing upgrades during the cloud migration project.

Funds are available in the following Account #: 101-1209-82602.

Respectfully Submitted,

Craig Treppa
 Purchasing Agent

Approved By:	Signature	Date
Budget Director:		5/20/2024
Controller:		5/20/2024
MAYOR:		5/21/2024

Change Request

BS&A Software, LLC | bsasoftware.com | 855 BSASOFT

Customer: **City of Warren, Macomb County MI**

Prepared By: Steve Rennell, Account Executive

Change #	1	Date Submitted	4/24/2024
		Date Required	4/24/2024
Module/Area Affected	Cloud Property		

No.	Changed Deliverable	Reason or Description	Net Change in Cost
1	Additional Implementation and Training for Assessing	3 days @ \$1,200/day	\$3,600
2	Add related Travel Expenses		\$440
Total Net Changes			\$4,040.00

BS&A Software, LLC

By: _____

Name: _____

Title: _____

Date: _____

Customer

By: _____

Name: _____

Title: _____

Date: _____



INFORMATION SYSTEMS
ONE CITY SQUARE, SUITE 420
WARREN, MI 48093-6726
(586) 574-4612
www.cityofwarren.org

To: Craig Treppa

From: Shumon Hakim

Date: May 5, 2024

Re: BSA Cloud Migration Change Order (Price Increase)

I am requesting for the approval of price increase in the BSA cloud migration project. According to Steve Rennell, our account executive, the price increase is due to Assessing requiring more time on site. The following supporting documents are attached, email from Steve, new contract amendment, and the original agreement.

Change Request description:

- 1- \$3,600 - Additional Implementation and Training for Assessing
3 days @ \$1,200/day
- 2- \$440 - Travel Expense

Total increase: \$4,040

Thank you for your assistance in the matter.

A handwritten signature in black ink, appearing to read "Shumon Hakim", with a horizontal line extending to the right.

Shumon Hakim
Information Systems Manager

RESOLUTION

Document No: SOL-W-1107

Product or Service: Change Order for BS&A Cloud Migration Project

Requesting Department: I.S.

At a Regular Meeting of the City Council of the City of Warren, County of Macomb, Michigan, held on _____, 2024 at 7:00 p.m. Local Time, in the Council Chamber at the Warren Community Center Auditorium, 5460 Arden, Warren, Michigan.

PRESENT: Councilmembers: _____

ABSENT: Councilmembers: _____

The following preamble and resolution were offered by Councilmember _____ and supported by Councilmember _____.

Upon performing a diligent inquiry, the I.S. Manager has determined that it is necessary in the interests of the I.S. Department and the City, to approve a change order request in the amount of \$4,040.00 for the Assessing upgrades of the BS&A Cloud Migration Project being performed by sole source provider, BS&A Software, 14965 Abbey Lane, Bath, MI 48808.

The Purchasing Agent has conducted a review and concurs with the sole procurement.

Funds are available annually in the following Account: 101-1209-82602.

IT IS RESOLVED, that the change order through the sole source provider, BS&A Software, is hereby accepted by City Council in an amount of \$4,040.00.

IT IS FURTHER RESOLVED, that the Purchasing Agent and/or Mayor and



CITY CONTROLLER'S OFFICE

ONE CITY SQUARE, SUITE 425

WARREN, MI 48093-5289

(586) 574-4600

FAX (586) 574-4614

www.cityofwarren.org

DATE: MAY 10, 2024
TO: MINDY MOORE, SECRETARY, WARREN CITY COUNCIL
SUBJECT: FILE TRI-W-1221 – RECOMMENDATION TO FURNISH AND INSTALL PLAYGROUND EQUIPMENT FOR LICHT PARK UTILIZING THE SOURCEWELL COOPERATIVE CONTRACT #010521-LTS

The Purchasing Division concurs with the Parks and Recreation (P&R) Department and recommends that City Council authorize the Furnish and Installation of Playground Equipment at Licht Park from webuildfun, Inc., PO Box 29, Allen, TX 75013 utilizing the Sourcewell Cooperative Contract #010521-LTS with PlayPower, Inc., 11515 Vanstory Drive #100, Huntersville, NC 28078 (Miracle Recreation), in the total amount of \$597,469.90.

The Parks and Recreation Department is seeking to replace existing playground equipment with new structures at Licht Park. The current equipment has exceeded its useful life. The new equipment will best meet the needs of the residents of Warren. Layouts of the play structures are attached for your review. Please see attached quotation to see what the project includes.

In addition to the playground equipment, the project will include the removal and disposal of the current playground equipment along with the removal and disposal of existing safety surfacing. Concrete curbing will be installed around the perimeter of the playground area.

Webuildfun is the representative for Miracle Recreation.

Funds are available in the following Account: 208-9208-98462.

This project be reimbursed from a Community Enhancement Grant awarded to the City.

Respectfully Submitted,

Craig Treppa
Purchasing Agent

Approved By:	Signature	Date
Budget Director:		5/20/2024
Controller:		5/20/2024
MAYOR:		5/21/2024



CONTRACT EXTENSION

Contract Number: #010521-LTS

Sourcewell, 202 12th Street Northeast, P.O. Box 219, Staples, MN 56479 (Sourcewell) and PlayPower, Inc. (Vendor) 11515 Vanstory Drive, Huntersville, NC 28078 have entered into Contract #010521-LTS for the procurement of Playground and Water Play Equipment with Related Accessories and Services. The Contract has an expiration date of February 17, 2025, but the parties may extend the Contract by mutual consent.

Sourcewell and Vendor acknowledge that extending the Contract benefits the Vendor, Sourcewell and Sourcewell's Members. Vendor and Sourcewell agree to extend the Contract listed above for an additional period, with a new Contract expiration date of February 17, 2026. All other terms and conditions of the Contract remain in full force and effect.

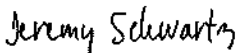
Sourcewell
DocuSigned by:

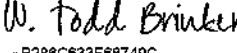
By: C0FD2A139D08489...
Jeremy Schwartz
Title: Chief Procurement Officer
Date: 9/23/2023 | 10:52 AM CDT

PlayPower, Inc.
DocuSigned by:

By: B288C633F68749C...
W. Todd Brinker
Title:
Date: 9/25/2023 | 4:14 PM CDT



- **About Us**
- **Brands**
- **Education**
- **News**
- **Contact**
- **Careers**

Brands

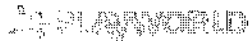
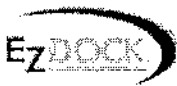
PlayPower is a family of brands that believe in the power of play. Each wholly-owned subsidiary is dedicated to providing fun, safe play solutions that put smiles on people's faces. The exceptional design and durability of our products are unmatched in the industry. Explore our brands' full capabilities below.



WABASH VALLEY



Miracle Recreation Equipment is a leading producer of innovative, durable, and inclusive play spaces for a variety of commercial needs. Our experience shines through in our broad range of customized and themed commercial systems designed to thrill children of all ages and abilities. Meeting high standards of quality, safety and accessibility, Miracle is where everyone can go when they're ready to play. **Find your right choice at the right price by following the link below.**

miracle-recreation.com

Miracle Recreation Equipment Company

878 E Highway 60

Monett, MO 65708

P 888-458-2752 • F 417-235-3551



- OUR PRODUCTS
- MARKETS
- PLANNING
- ABOUT US
- GALLERIES
- CONTACT

Find a Sales Representative

United States of America

webuildfun, Inc.

P.O. Box 29,
Allen, TX 74013

<https://www.webuildfun.com/>

[Contact Us](#)



Proposal Evaluation
Playground and Water Play Equipment with Related Accessories and Services RFP #010521

Possible Points		ABC WATER PRODUCTS INC	AquaWorx, Inc.	BCI Burke Company, LLC	Berliner Seilfabrik Play Equipment Corporation	Columbia Cascade Company	CXT Inc	Ecore International	Henderson Recreation Equipment Limited	Industrial Shadeports Inc.	Keystone Ridge Designs, Inc.	Landscape Structures Inc.	North West Rubber	PlayPower
Conformance to RFP Requirements	50	32	38	42	37	37	35	37	41	35	43	44	41	43
Pricing	400	322	335	329	278	308	344	323	322	334	336	330	325	342
Financial Viability and Marketplace Success	75	49	54	66	54	51	51	60	57	52	62	66	56	68
Ability to Sell and Deliver Service	100	69	81	83	71	66	78	78	78	65	81	83	80	87
Marketing Plan	50	36	42	43	35	37	39	36	37	38	42	43	37	44
Value Added Attributes	75	45	59	65	57	57	63	60	61	62	63	67	56	67
Warranty	50	42	43	44	42	39	38	40	44	43	42	42	41	43
Depth and Breadth of Offered Equipment, Products, or Services	200	156	155	166	147	148	123	143	154	135	144	177	138	178
Total Points	1,000	751	809	838	721	742	781	777	794	764	813	852	774	872
Rank Order		20	10	5	29	22	14.5	18	13	18	8	2	17	1

Possible Points		Prophat Corp.	Public Restroom Company	Balndrop Produces LLC	Rubbersycle LLC	Ry-Lacia Corp	Saris Cycling Group	SoftSurfaces, Inc	The Fountain People	The Recreational Group	TUMV Inc dba American Fence Company	Vertex USA	Waterplay Solutions
Conformance to RFP Requirements	50	42	38	41	37	36	36	45	36	41	37	41	44
Pricing	400	332	316	343	330	259	328	333	331	346	307	299	341
Financial Viability and Marketplace Success	75	58	62	68	60	51	56	62	60	57	49	64	64
Ability to Sell and Deliver Service	100	78	73	83	80	60	74	85	76	76	62	84	82
Marketing Plan	50	44	43	45	35	30	40	44	40	42	37	43	48
Value Added Attributes	75	62	61	66	60	34	60	65	58	58	52	62	67
Warranty	50	45	43	43	43	37	43	46	43	42	42	40	42
Depth and Breadth of Offered Equipment, Products, or Services	200	158	130	166	151	136	115	148	157	147	134	186	164
Total Points	1,000	819	766	851	797	648	750	826	781	809	720	799	847
Rank Order		7	18	3	32	25	21	6	14.5	9	24	11	4

DocuSigned by:

 5836d13c3e3a40d
 Kim Austin, MBA, CPPB, Procurement Lead Analyst

DocuSigned by:

 080201e46d2e41e
 Michael Muñoz, CPPB, Procurement Analyst

DocuSigned by:

 02e61a2e2e0d0c40e
 Carol Jackson, Procurement Analyst

DocuSigned by:

 3839dc13f164c7c
 Beverly Hoernberg, Procurement Analyst



Miracle Recreation Representative Listing United States and Canada

MIRACLE RECREATION EQUIPMENT COMPANY LINK

2024 MIRACLE CATALOG LINK

WHY CHOOSE MIRACLE RECREATION VIDEO - SHAPING THE FUTURE OF PLAY

REP ORGANIZATIONS	TERRITORIES SERVICED	REP PRINCIPLE	MAILING ADDRESS	PHONE #	FAX #	E-MAIL ADDRESS	COMPANY WEBSITE
ASH RECREATION & DESIGN	AR; OK	Brian Ash	931 Monterey Court Monett, MO 65708	800-933-6484 417-393-5788 cell	N/A	brian@ashrecreation.com	https://www.miracle-recreation.com/
BOLAND RECREATION, INC.	IA, WI	Mark Boland	2347 Oak Park Rd. Marshalltown, Ia. 50158	641-752-7589 641-751-5338 cell	641-752-6604	iowaparkplace@mchsi.com	http://www.bojandrecreation.com/
CHURCHICH RECREATION & DESIGN (CRD OF HILTON HEAD)	SC; S. NC	Jeff Churchich	20 Towne Dr., PMB 186 Bluffton, SC 29910	843-757-3156 843-368-8170 cell	843-757-3150	jeff@churchichrecreation.com	https://churchichrecreation.com/
CHURCHICH RECREATION, LLC	CO; E WY; NE,	Kit Steven	PO Box 263 Alamo, CA 94507	510-893-2162 510-295-9507 cell	510-893-2163	kit@miracleplaygroup.com	https://www.miracleplaygroup.com/
CREATIVE RECREATION, LLC	CT; RI; S. E. MA	John Hollerbach	PO Box 330235 W Hartford, CT 06133-0235	860-953-5336	860-953-5337	john@creativerec.com	https://www.creativerec.com/
CUSTOM PLAY SYSTEMS, INC.	KS; W. MO	Greg Stein	5901 NE Diamond Circle Lee's Summit, MO 64064	816-795-7795	816-350-0080	gstein@customplaysystems.com	https://www.customplaysystems.com/
DENZAK RECREATIONAL DESIGN AND SUPPLY	W. NY	Joe Denzak	PO Box 15517 Syracuse, NY 13215	315-492-2631	315-492-2633	drecreat@twcny.rr.com	https://www.denzakrec.com/
GARRETT & COMPANY, INC	ID; UT; W. WY, MT	Vern Garrett	PO Box 57426 Murray, UT 84157	801-265-8443 801-232-4576 cell	801-263-1254	vern@garrettandcompany.com	https://garrettandcompany.com/
HASLEY RECREATION, INC	AL; GA	Eric Hasley	P.O. Box 489 Flowery Branch, GA 30542	770-965-4042	770-936-1970	ehasley@hasley-recreation.com	https://hasley-recreation.com/
HUTCHINSON RECREATION & DESIGN	E. MO; S. IL	Brad & Curt Hutchinson		314-436-5000	636-528-8413	brad@hutchinson-recreation.com curt@hutchinson-recreation.com	https://www.hutchinson-recreation.com/
MIRACLE RECREATION - REGIONAL SALES DIRECTOR	MS	Anthony Cordova	878 E Highway 60 Monett, MO 65708	801-674-0464	N/A	anthony.cordova@playpower.com	https://www.miracle-recreation.com/
KINCADE RECREATION	LA	Tracey Kincade	PO Box 1762 Livingston, TX 77351	936-328-9733 936-328-9733 cell	N/A	kincaderecreation@eastex.net	http://kincaderecreation.net/
LIBERTY PARKS & PLAYGROUNDS	DE; NJ	Joel Lyons	P.O. Box 53 Stratford, NJ 08084	877-808-1583 856-264-4008	888-324-3929	joel@lyonsrecreation.com	https://www.lyonsrecreation.com/
LYONS RECREATION	E. PA	Joel Lyons	P.O. Box 53 Stratford, NJ 08084	877-808-1583 856-264-4008	888-324-3929	joel@lyonsrecreation.com	https://www.lyonsrecreation.com/
MAINE RECREATION & DESIGN	ME	Eric Welzel	347 Lunt Rd. Brunswick, ME 04011	207-729-9368 207-751-4323 cell	N/A	eric@maine-playgrounds.com	https://www.maine-playgrounds.com/
MAY RECREATION EQUIPMENT & DESIGN	S.E. TX	Randy May	3 Sunspree Place The Woodlands, TX 77382	281-363-1908 800-964-6301	281-310-8812	randy@mayrecreation.com	https://mayrecreation.com/
METRO RECREATION	District of Columbia; MD; WV	Michael Slifer	4907 Camden Place N Jefferson, MD 21755	240-409-2870	240-490-5162	mike@metrorecreation.com	https://metrorecreation.com/
MILLER RECREATION EQUIPMENT & DESIGN	W. & C. FL	Joe & Susan Miller	2017 91st Street N.W. Bradenton, FL 34209	941-792-4580	941-794-2909	mrecfla@tampabay.rr.com	https://www.millerrecreation.com/

MIRACLE OF KY & TN	KY; TN	Tami Phillips	931 Commerce Drive Leitchfield, KY 42754	270-230-0221	270-230-0210	tami@miraclekytn.com	https://miraclekytn.com/
MIRACLE OF SOUTH FLORIDA	S. FL	Connie Brown	14451 Lexington Place Davie, FL 33325	954-520-4523 cell	954-473-1964	connieb@miracleofsouthflorida.com	https://www.facebook.com/people/Miracle-of-South-Florida/100057472839055/
Miracle Playgrounds of Indiana	IN	Megan Miller	PO Box 4045 Lawrenceburg, IN 47025	877-220-6705	N/A	megan@miracleofindiana.com	https://www.miracleindiana.com/
MIRACLE PLAYGROUND SALES, INC.	S. CA	Kelly Spence	9106 Pulsar Ct, Suite C Corona, CA 92883	951-695-4515	877-215-3869	kelly.spence@miracleplayground.com	https://www.miracleplayground.com/
MIRACLE PLAYGROUND SALES OF SOUTHERN CALIFORNIA LLC	S. & C. CA	Robert Fryhoff	9106 Pulsar Ct, Suite C Corona, CA 92883	951-695-4515 714-267-7457 cell	877-215-3869	rfryhoff@miracleplayground.com	https://www.miracleplayground.com/
MIRACLE PLAYGROUND SALES SW	AZ; NV	Monte Corley	9106 Pulsar Ct, Suite C Corona, CA 92883	951-695-4515 602-315-5144 cell	877-215-3869	monte@miracleplayground.com	https://www.miracleplayground.com/
MIRACLE PLAYSYSTEMS INCORPORATED	N. & C. CA, OR, WA	Kit Steven	PO Box 263 Alamo, CA 94507	510-893-2162 510-295-9507 cell	510-893-2163	kit@miracleplaygroup.com	https://www.miracleplaygroup.com/
PARK & RECREATION SUPPLY / TEAM REIL	N. IL	John Cederlund	17421 Marengo Road Union, IL 60180	815-923-2099 815-482-2510 cell	815-923-2204	john@getreil.com	https://getreil.com/
PARK PLACE RECREATION DESIGNS	S. TX	Bob Ahrens	PO Box 18186 San Antonio, TX 78218	210-821-5878 210-416-6482 cell	210-832-0115	bob@miracleparkplace.com	https://miracleparkplace.com/
PETTINELLI & ASSOCIATES, INC	NH; VT	Robert Pettinelli	PO Box 5814 Burlington, VT 05402	802-862-3002	802-862-3112	playgrdbob@aol.com	http://pettinelliandassociates.com/
PETTINELLI RECREATION, INC	S. NY; Long Island NY, NYC	Robert K. Pettinelli, Jr	199 Blessings Road Slingerland, NY 12159	518-461-5917	518-326-9859	robertk@pettinelliandassociates.com	https://pettinellirecreation.com/
PLAYGROUND EQUIPMENT SERVICES	OH	Eric Schmidt	3460 Oakmeadow Lane Cincinnati, OH 45239	513-923-2333	513-923-2444	eric@playgroundequipmentservices.com	https://www.playgroundequipmentservices.com/
REC AND ROLL, LLC	HI	Rory Otto	580 Dillingham Blvd. Honolulu, HI 96817	808-485-8885 808-630-1064 cell	N/A	Rory@nylawn.com	https://www.recandrollhawaii.com/
SITE CONCEPTS	VA; N. NC	Jack Huffman	PO Box 9309 Chesapeake, VA 23321	757-465-5701 757-383-8405 cell	757-465-5739	jack@siteconceptsva.com	http://www.siteconceptsva.com/
SITE SPECIFICS	N, W, C MA	Cindy Maak	PO BOX 325 Rochester, MA 02770	508-763-0207 508-633-0722 cell	508-763-0208	cindy@sitespecifics.net	https://www.sitespecifics.net/
SPORTS AND RECREATION ASSOCIATES, LLC	W. PA	Mark Ford	1950 Shady Plain Road Apollo, PA 15613	724-478-1775	724-478-1785	mford46928@aol.com	http://www.sportsrecassoc.com/
TRUE NORTH RECREATION	N. & Panhandle FL	Rich & Kim Falkowski	500 Alfani St Davenport, FL 33896	407-883-8463	N/A	miracle@truenorthrecreation.com	https://www.miracle-recreation.com/
WEBBER RECREATIONAL DESIGN	MN, ND, SD	Jay Webber	1442 Brooke Court Hastings, MN 55033	651-438-3630 612-581-4704 cell	651-438-3939	jwebber@webberrec.com	https://webberrec.com/
WEBBILDFUN, INC	C. TX, W TX, Tx Panhandle, NM, MI	Vince Allen	PO Box 29 Allen, TX 75013	972-727-0653 214-869-2197 cell	972-396-4994	va@webuildfun.com	https://www.webuildfun.com/

CANADA REP AGENCIES

CANADIAN RECREATION SOLUTIONS	AB; BC; SK	Robert McCoy	#74, 52328 Hwy 21 Sherwood Park, AB T8B 1J9	780-465-0123	N/A	robert@canadianrecreationolutions.com	
COASTLINE SPECIALTIES LIMITED	NL	John Pike & Seth Pike	46 Robin Hood Bay Road St. John's, NL A1A 5V3	709-726-9155	N/A	john@coastlinespecialties.ca seth@coastlinespecialties.ca	

PLAYGROUND PLANNERS	E. ON	Maryanne & Shannon Swinimer	14 Laurentide Road Napan ON K2H 6T5	613-828-5502	N/A	shannon@playgroundplanners.com maryanne@playgroundplanners.com	
CRCS	N. ON & MB	Melissa Sheridan	103 Napa Valley Dr Sudbury, ON P3E 0G8	705-522-5555	N/A	Melissa@crsrecreation.ca	
KETZA CONSTRUCTION	YT & NT	Eric Brohman	107 Platinum Road Whitehorse, YT Y1A 5M3	647-386-6447	N/A	ebrohman@ketza.ca	
PPLT CANADA	C. ON	Robb Wilson	P. O. Box 125 Paris ON N3L 3E7	519-757-7573	N/A	robb.wilson@playpower.com	
PPLT CANADA	S.W. ON	Loreen Warner	P. O. Box 125 Paris ON N3L 3E7	519-732-0072	N/A	loreen.warner@playpower.com	
PPLT CANADA	W. ON	Steve Howes	P. O. Box 125 Paris ON N3L 3E7	519-770-7717	N/A	steve.howes@playpower.com	
PPLT CANADA	S. & C. ON	Jake Hoogstraten	P. O. Box 125 Paris ON N3L 3E7	519-761-7752	N/A	jake.hoogstraten@playpower.com	
PPLT CANADA	Maritime Provinces; NS; PE; NB	Scott O'Reilly	76 Astour Drive Eastern Passage, NS B3G 1M7	902-471-1415	N/A	scott.oreilly@playpower.com	
TECHSPORT	QC	Casey Cameron	4994 Route 125 Rawdon, Quebec. J0K 1S0	514-796-3222	N/A	casey@techsport.ca	
PPLT CANADA	Any other Eastern territories	Michael Lovering	P. O. Box 125 Paris ON N3L 3E7	519-757-2767	N/A	michael.lovering@playpower.com	
PPLT CANADA	Any other Western territories	Lorraine Friesen	861 Raymer Road, Kelowna, British Columbia, Canada V1W 1J7	250-681-5117	N/A	lorraine.friesen@playpower.com	

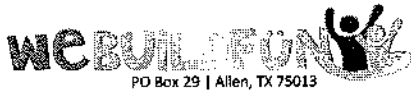

PO Box 29 | Allen, TX 75013



Miracle

of Michigan

CUSTOMER INFORMATION

Customer: **City of Warren**
 Contact: **Anthony Casasanta**
 Contact Info: **586-258-2008** **acasasanta@cityofwarren.org**
 Project Name: **Licht Park Playground Equipment**
 Site Address: **27400 Campbell Rd, Warren, MI 48093**
 End User: **City of Warren**
 Ship To:

CONSULTANT	
Keith Alexander	(734) 560-5537
QUOTE	
Quote Date	Valid Until
5/9/2024	6/8/2024
Est. Delivery:	Est. Install
6-8 Weeks	

ITEM	DESCRIPTION	QTY	EACH	TOTAL
MIRACLE	Miracle playground equipment design 61_45372684521	1	\$306,440.00	\$306,440.00
BENCHES	(4) 6' Bench w/back, rolled edges, expanded metal, Inground, Industry standard coating	1	\$2,768.50	\$2,768.50
FREIGHT	Shipping of Miracle equipment	1	\$12,936.25	\$12,936.25
DISCOUNT	Sourcewell Contract #010521-LTS, Customer ID #16557	1	-\$116,447.20	-\$116,447.20
Safety Surfacing	8040 square feet of Playground Grass Academy. Includes 4" stone sub-base, perimeter boards, safety foam to meet required critical fall heights and installation materials.	1	\$143,967.11	\$143,967.11
INSTALL	Unload and install playground equipment, includes prevailing wage. Does not include any permits or inspections.	1	\$139,130.20	\$139,130.20
	Demo existing playground equipment and excavate and dispose of existing safety surfacing.	1	\$69,264.80	\$69,264.80
	364 linear feet of concrete curb 6" wide x 8" deep around the perimeter of the playground area. Includes 30' long x 5' wide, 4" thick concrete walk from path to playground area.	1	\$18,010.24	\$18,010.24
	Restore approximately 10,000 square feet of playground area with existing equipment.	1	\$21,400.00	\$21,400.00

TAX	Estimated Sales Tax (please provide tax exemption certificate to remove sales tax)	6.00%
	Final Prices Subject to State and Local Sales Tax and Use Tax Rate	
	TOTAL	\$597,469.90

Make Payable to: **webuildfun, Inc PO Box 29, Allen, TX 75013**

Payment Terms: **Other** **Net 45 days**

Prices reflected on quote assumes all site work to be done by others unless noted above.

* All drainage within the playground border and away from the play area to be done by "other" unless noted above. * Price assumes border by "other" unless noted above.
 * No site restoration is included unless noted above. * Additionally, no bond or special insurance coverages are included unless noted above.

Pricing may not be guaranteed beyond 30 days. We are attempting to hold pricing when possible, but due to material and labor costs, price increases have unfortunately become unavoidable. We value our customers and appreciate your understanding during these unprecedented times. All finalized contracts and/or purchase orders must be accompanied by a valid quote within 30 days of issue. Please request a requote when beyond the 30 days.

Approval Signature

Date

PO Number

Send completed quote and purchase order to: **keith@webuildfun.com**

PLEASE RETURN ALL PAGES OF THIS QUOTE UPON ORDERING

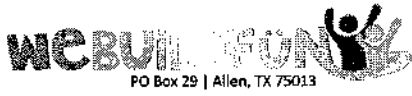

PO Box 29 | Allen, TX 75013



CUSTOMER INFORMATION

Customer: **City of Warren**
 Contact: **Anthony Casasanta**
 Contact Info: **586-258-2008** **acasasanta@cityofwarren.org**
 Project Name: **Licht Park Playground Equipment**
 Site Address: **27400 Campbell Rd, Warren, MI 48093**
 End User: **City of Warren**
 Ship To:

Please provide the following information:

Project Name: **Licht Park Playground Equipment**

Est Project Start Date: _____ Bond Required _____

Est Project Completion Date: _____ Contract Required _____

Add'l Details: _____

CONSULTANT	
Keith Alexander	(734) 560-5537

QUOTE	
Quote Date	Valid Until
5/9/2024	6/8/2024
Est. Delivery:	Est. Install
6-8 Weeks	

Project Total
\$597,469.90

Purchase Order # _____

PROJECT DETAILS

SHIPPING INFO		INVOICE INFO	
Company		Company	
Street Address		Street Address	
City, State, Zip		City, State, Zip	
Contact:		Contact:	
Phone #		Phone #	
Email:		Email:	

Initial here to approve colors shown above

PLEASE RETURN ALL PAGES OF THIS QUOTE UPON ORDERING

Licht Park Warren, MI

FOR KIDS AGES
5-12
THRU

AGE GROUP: 5-12
ELEVATED PLAY ACTIVITIES - TOTAL: 22
ELEVATED PLAY ACTIVITIES ACCESSIBLE BY TRANSFER: 18 REQ'D 0
ELEVATED PLAY ACTIVITIES ACCESSIBLE BY RAMP: 18 REQ'D 11
GROUND LEVEL ACTIVITY TYPE: 5 REQ'D 0
GROUND LEVEL ACTIVITY QUANTITY: 24 REQ'D 0

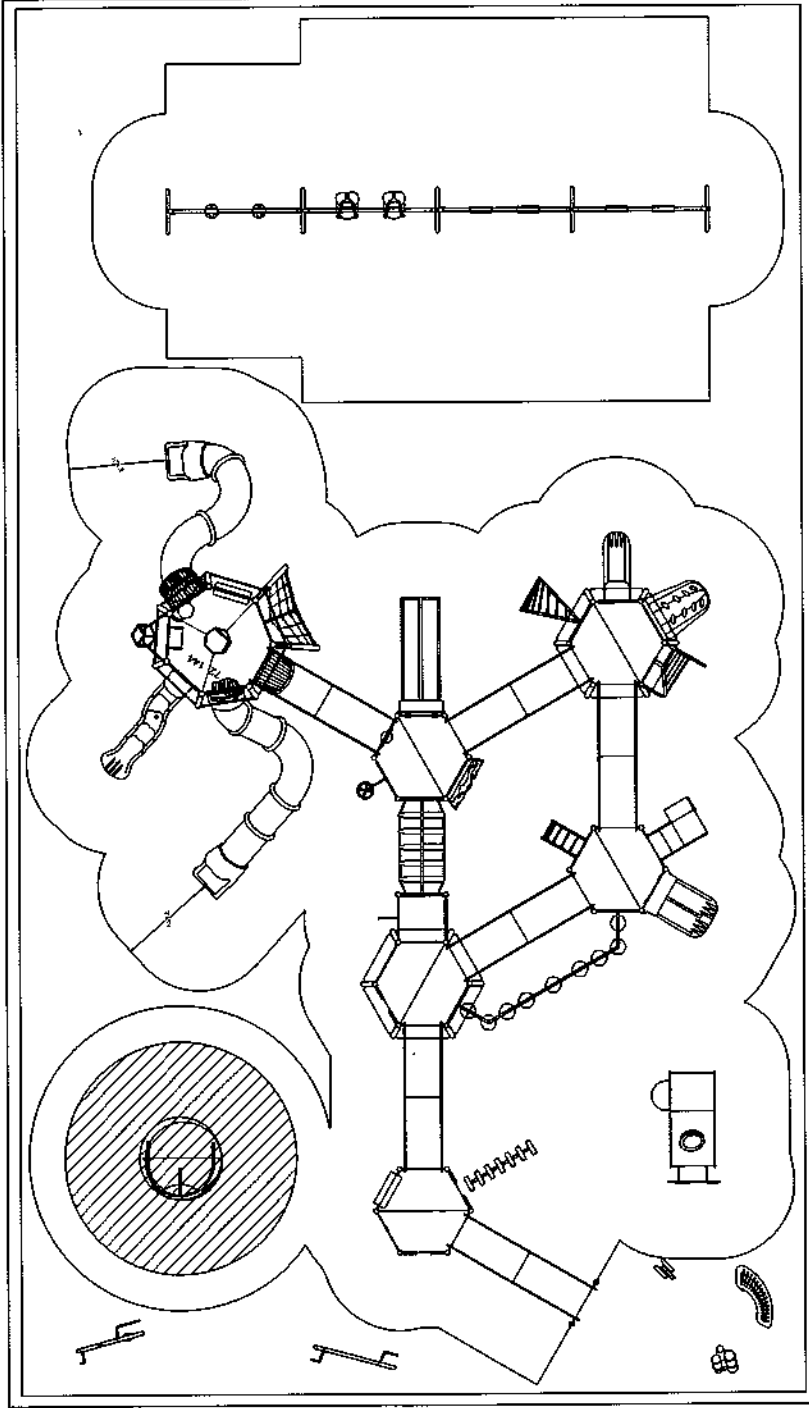

THE PLAY COMPONENTS IDENTIFIED IN THIS PLAN ARE IPEMA CERTIFIED. THE USE AND LAYOUT OF THESE COMPONENTS CONFORM TO THE REQUIREMENTS OF ASTM F1487.

AN ENERGY ABSORBING PROTECTIVE SURFACE IS REQUIRED UNDER & AROUND ALL PLAY SYSTEMS

To promote safe and proper equipment use by children, Miracle recommends the installation of either a Miracle safety sign or other appropriate safety signage near each play system's main entry point(s) to inform parents and supervisors of the age appropriateness of the play system and general rules for safe play.

R0061_45372684521

COMPLIES TO ASTM/CPSC

COMPLIES TO ADA

webuildfun, Inc
103 W. McDermott, #300
Allen, TX

PHONE NO: (972) 727-0653
FAX NO: (972) 396-4994

GROUND SPACE: 100'-0" x 60'-0"
PROTECTIVE AREA: 114'-0" x 84'-9"

DATE: 3/26/2024
DRAWN BY: Chris Yanko

Licht Park Warren, MI

AGE GROUP: 5-12
 ELEVATED PLAY ACTIVITIES - TOTAL: 22
 ELEVATED PLAY ACTIVITIES ACCESSIBLE BY TRANSFER: 18 REQ'D 0
 ELEVATED PLAY ACTIVITIES ACCESSIBLE BY RAMP: 18 REQ'D 11
 GROUND LEVEL ACTIVITY TYPE: 5 REQ'D 0
 GROUND LEVEL QUANTITY: 24 REQ'D 0

FOR KIDS AGES
5-12
 YEARS

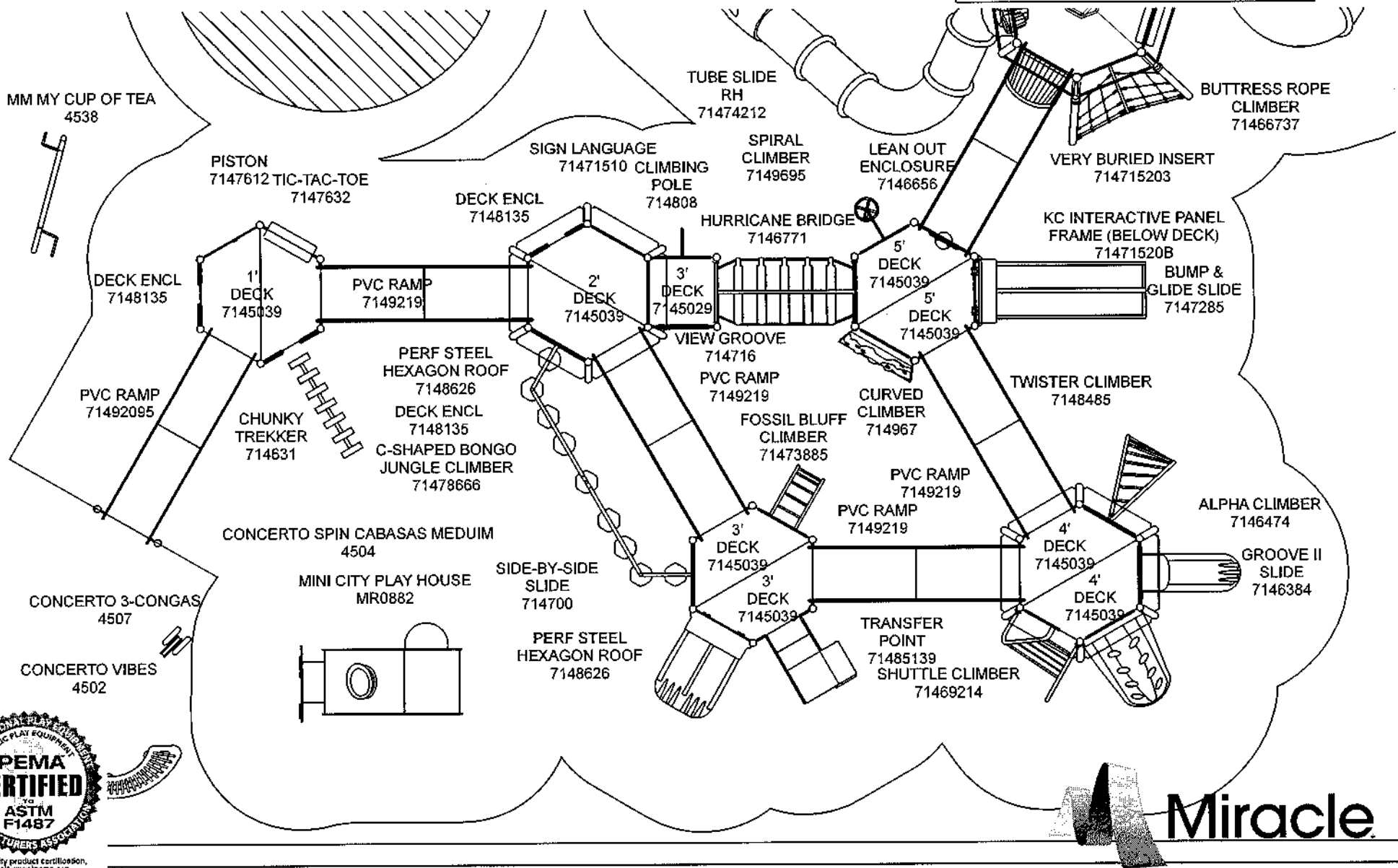

webuildfun, Inc

103 W. McDermott, #300
 Allen, TX

PHONE NO: (972) 727-0553
 FAX NO: (972) 396-4994

GROUND SPACE: 100'-0" x 60'-0"

PROTECTIVE AREA: 114'-0" x 64'-8"

DRAWN BY: Chris Yanko

DATE: 3/26/2024

R0061_45372684521

COMPLIES TO ASTM/CPSC

COMPLIES TO ADA

To promote safe and proper equipment use by children, Miracle recommends the installation of either a Miracle safety sign or other appropriate safety signage near each play system's main entry point(s) to inform parents and supervisors of the age appropriateness of the play system and general rules for safe play.

THE PLAY COMPONENTS IDENTIFIED IN THIS PLAN ARE IPEMA CERTIFIED. THE USE AND LAYOUT OF THESE COMPONENTS CONFORM TO THE REQUIREMENTS OF ASTM F1487.

AN ENERGY ABSORBING PROTECTIVE SURFACE IS REQUIRED UNDER & AROUND ALL PLAY SYSTEMS

Licht Park Warren , MI

AGE GROUP: 5-12	
ELEVATED PLAY ACTIVITIES - TOTAL: 22	
ELEVATED PLAY ACTIVITIES ACCESSIBLE BY TRANSFER: 18 REQ'D 0	
ELEVATED PLAY ACTIVITIES ACCESSIBLE BY RAMP: 18 REQ'D 11	
GROUND LEVEL ACTIVITY TYPE: 5 REQ'D 0	
GROUND LEVEL QUANTITY: 24 REQ'D 0	

FOR KIDS AGES
5-12
YEARS

MM CURIOSITY
THRILLED THE CAT
4536

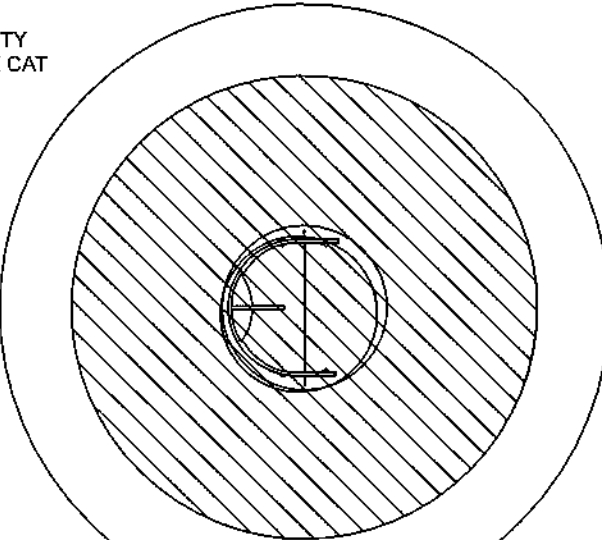

INCLUSIVE WHIRL (2023)
307

VERY BURIED INSERT
714715203

TUBE SLIDE
RH
71474212

KC INTERACTIVE PANEL
FRAME (BELOW DECK)
71471520B

FULL ENCLOSURE
W/SEAT
7148301

CHAMELEON II SLIDE
714670PZ

PVC RAMP
7149219

CALYPSO 3 DRUM
(BELOW DECK)
71471513B

UPPER
ENCLOSURE
7148302

FULL ENCLOSURE
WALL
71483012

WALL
714816

CHAMELEON II SLIDE
7146701

TREE-O
CLIMBER
7146056

PZ "S" TUBE
SLIDE RH
714742123R65

DOUBLE POD SEAT
7148174B

CRITTER PUZZLE
(BELOW DECK)
LEAN OUT 7147631B

ENCLOSURE
7146656

PERF STEEL
HEPTAGON ROOF
7148627

SENSORY PANEL
TEXTURED TRIANGLE HEXAGON MT
71483016

VIEW GROOVE
714716

HEPTAGON MEGA TOWER
714523C127

FULL ENCLOSURE
WALL
71483012

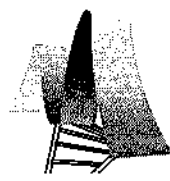

Miracle

webuildfun, Inc
103 W. McDermott, #300
Allen, TX

PHONE NO: (972) 727-0653
FAX NO: (972) 396-4994

R0061_45372684521

COMPLIES TO ASTM/CPSC

GROUND SPACE: 100'-0" x 60'-0"
PROTECTIVE AREA: 114'-0" x 64'-6"

COMPLIES TO ADA

To promote safe and proper equipment use by children, Miracle recommends the installation of either a Miracle safety sign or other appropriate safety signage near each play system's main entry point(s) to inform parents and supervisors of the age appropriateness of the play system and general rules for safe play.

THE PLAY COMPONENTS IDENTIFIED IN THIS PLAN ARE IPEMA CERTIFIED. THE USE AND LAYOUT OF THESE COMPONENTS CONFORM TO THE REQUIREMENTS OF ASTM F1487.

AN ENERGY ABSORBING PROTECTIVE SURFACE IS REQUIRED UNDER & AROUND ALL PLAY SYSTEMS

DRAWN BY: Chris Yanko

DATE: 3/28/2024

Licht Park

Warren, MI

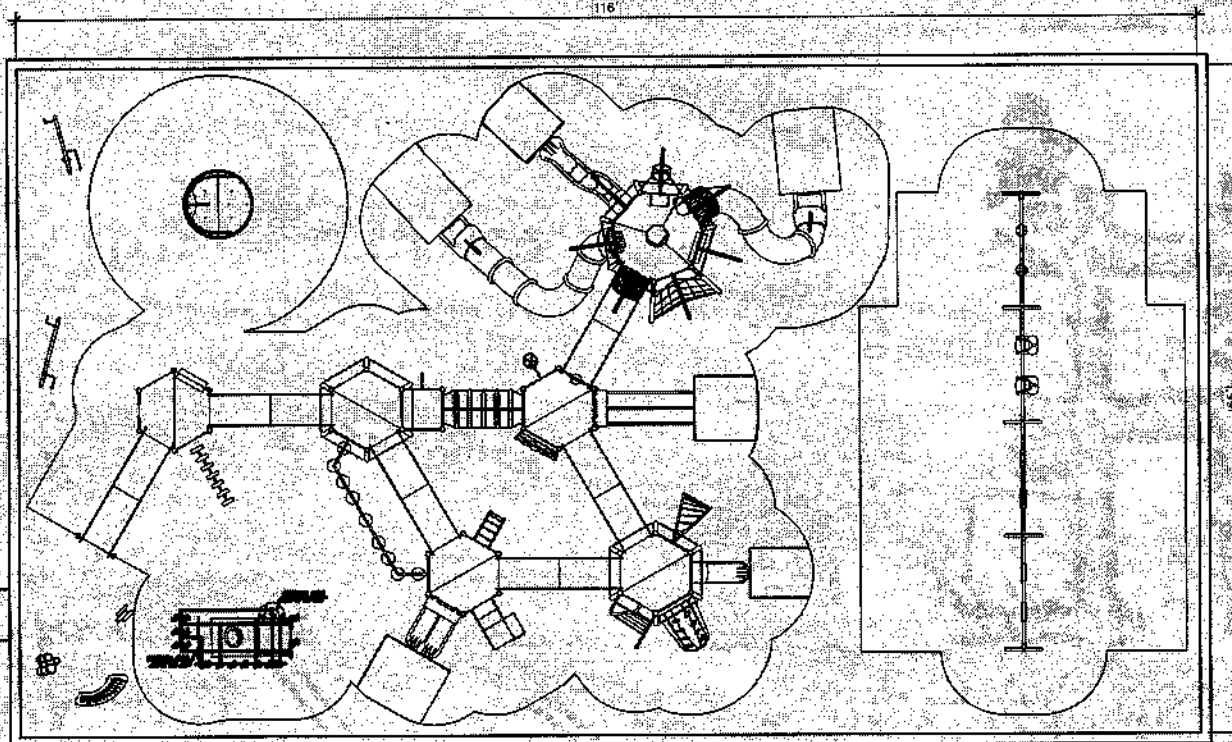

Licht Park
Warren Park

61_45372684521

GROUND SPACE

PROTECTIVE AREA

webuildfun, Inc.

103 W. McDermott #300
Allen, TX 75013

PHONE NO. 972-727-0653

FAX NO. 972-396-4994

DRAWN BY

DATE

\\SERVER\Company_Design and CAD\Templates\logo.png



To promote safe and proper equipment use by Children, Miracle recommends the installation of either a Miracle safety sign or other appropriate safety signage near each playstation's main entry point(s) to inform parents and supervisors of the age appropriateness of the playstation and general rules for safe play.



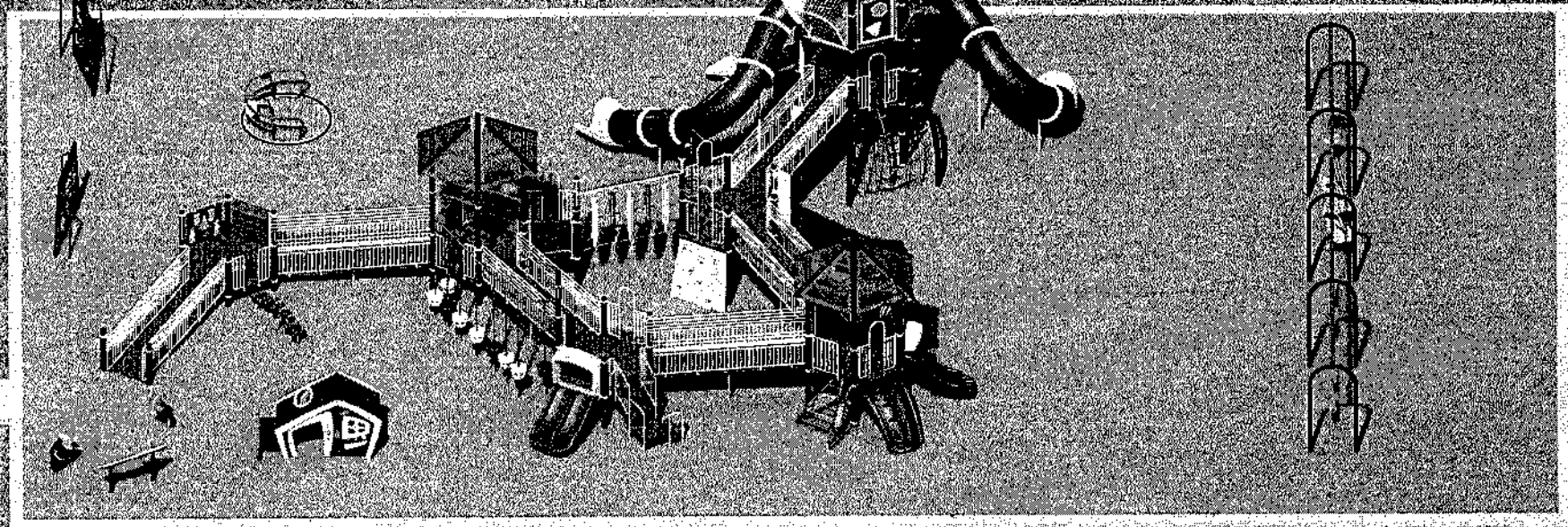

Deck



Green

Metals



Dark Brown



Forest Green



Lime



Beige

Plastics



Beige



Forest Green



Lime

Actual colors may vary. We work hard to ensure our renderings are as life-like as possible.

Licht Park
Warren, MI
R0061_45372684521



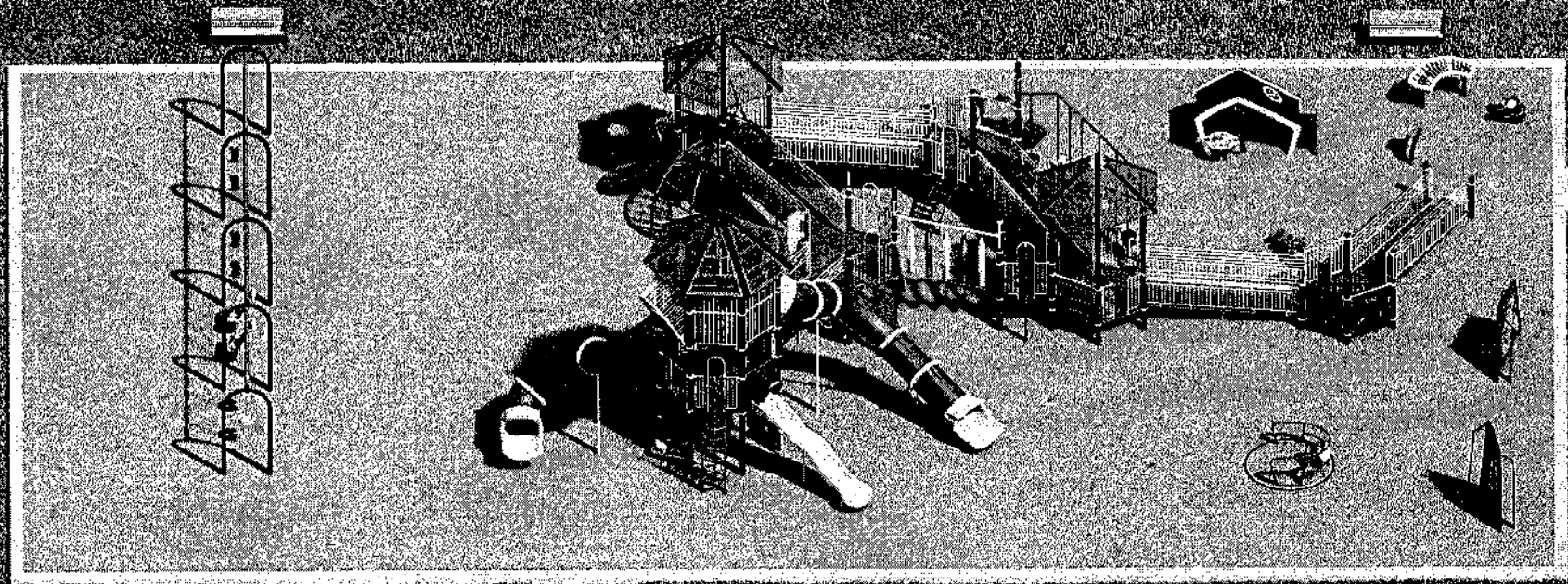

Deck



Green

Metals



Dark Brown



Forest Green



Lime



Beige

Plastics



Beige



Forest Green



Lime

Actual colors may vary. We work hard to ensure our renderings are as life-like as possible.

Licht Park
Warren, MI
R0061_45372684521



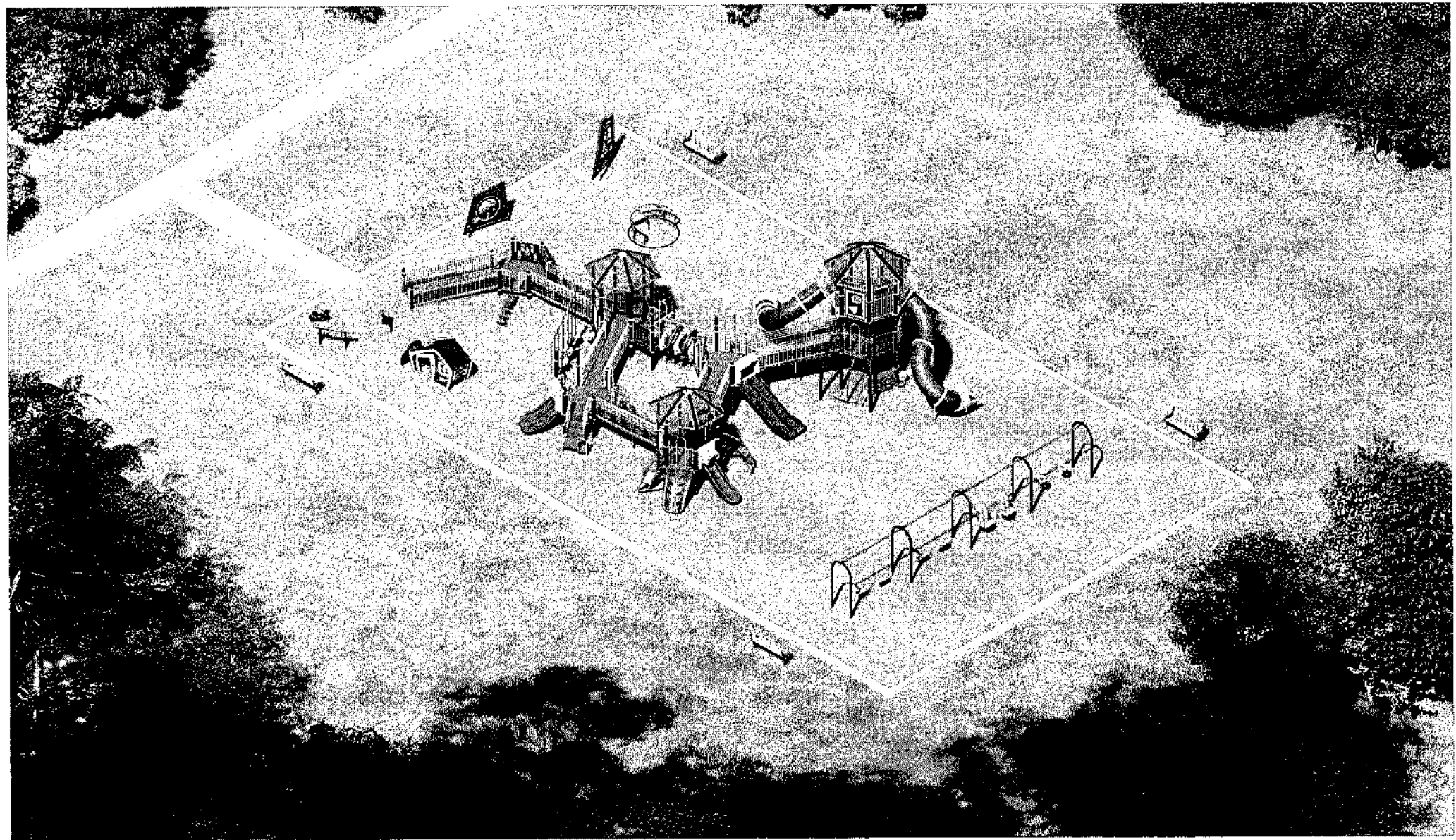

Deck



Green

Metals



Dark Brown



Forest Green



Lime



Beige

Plastics



Beige



Forest Green



Lime

Actual colors may vary. We work hard to ensure our renderings are as life-like as possible.

Licht Park
Warren, MI
R006L_45372684521





Deck



Green

Metals



Dark
Brown



Forest
Green



Lime



Beige

Plastics



Beige



Forest
Green



Lime

Actual colors may vary. We work hard to ensure our renderings are as life-like as possible.

Licht Park
Warren, MI
R0061_45372684521



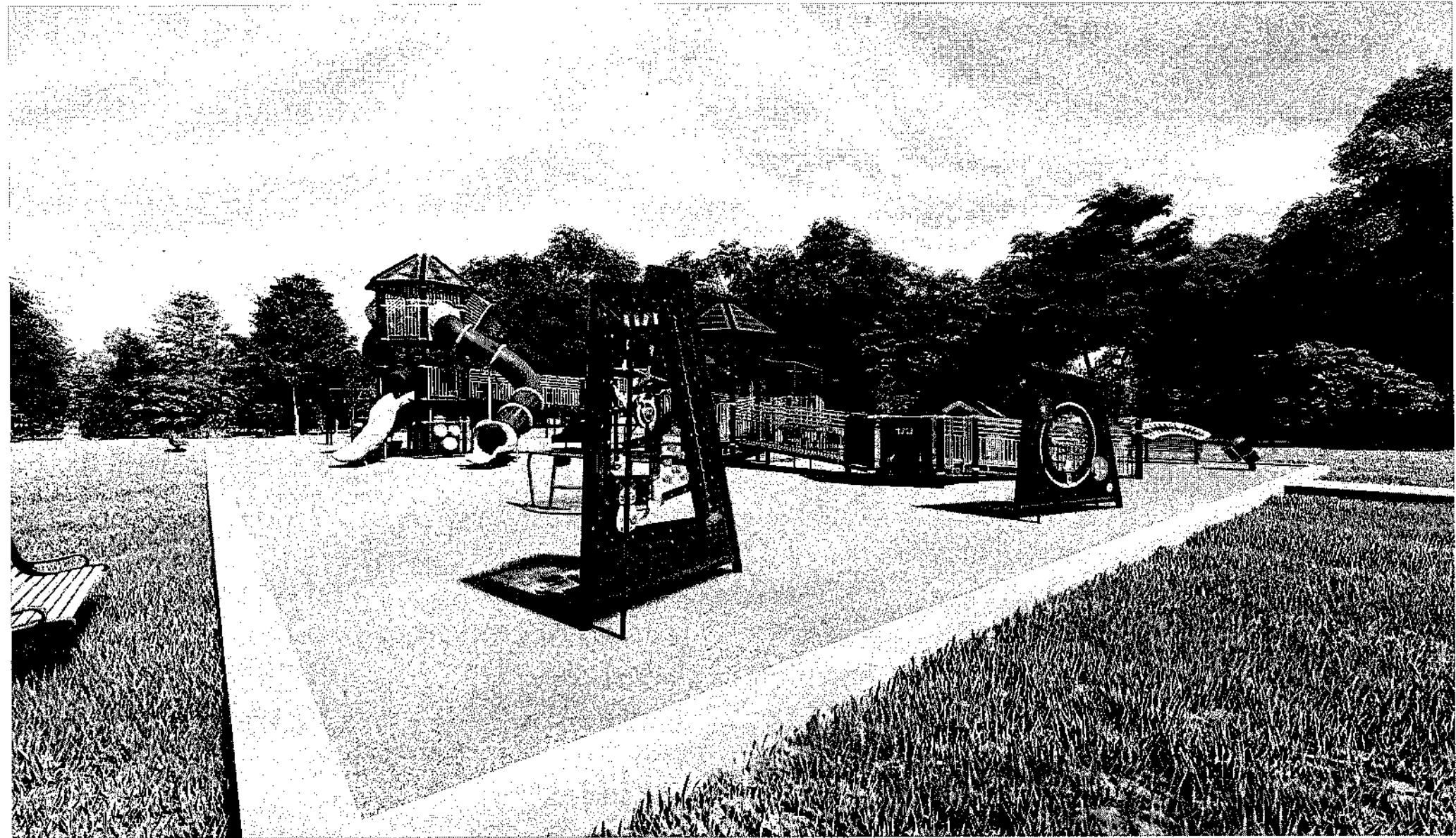

Deck



Green

Metals



Dark
Brown



Forest
Green



Lime



Beige

Plastics



Beige



Forest
Green



Lime

Actual colors may vary. We work hard to ensure our renderings are as life-like as possible.

Licht Park
Warren, MI
R0061_45372684521





Deck



Green

Metals



Dark
Brown



Forest
Green



Lime



Beige

Plastics



Beige



Forest
Green



Lime

Actual colors may vary. We work hard to ensure our renderings are as life-like as possible.

Licht Park
Warren, MI
R0061_45372684521





Deck



Green

Metals



Dark Brown



Forest Green



Lime



Beige

Plastics



Beige



Forest Green



Lime

Actual colors may vary. We work hard to ensure our renderings are as life-like as possible.

Licht Park
Warren, MI
R0061_45372684521





Deck



Green

Metals



Dark Brown



Forest Green



Lime



Beige

Plastics



Beige



Forest Green



Lime

Actual colors may vary. We work hard to ensure our renderings are as life-like as possible.

Licht Park
Warren, MI
R0061_45372684521



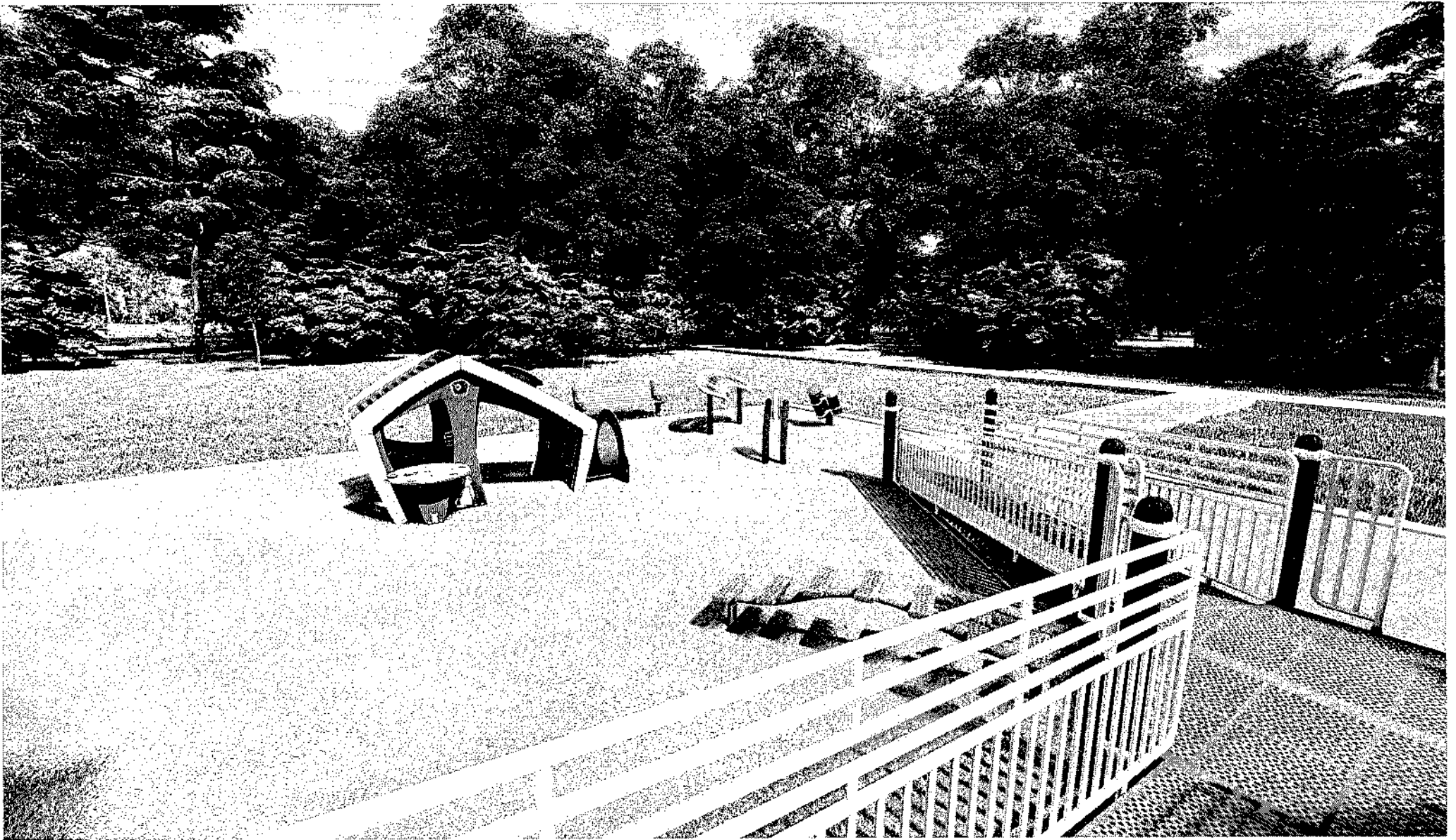

Deck



Green

Metals



Dark Brown



Forest Green



Lime



Beige

Plastics



Beige



Forest Green



Lime

Actual colors may vary. We work hard to ensure our renderings are as life-like as possible.

Licht Park
Warren, MI
R006L_45372684521



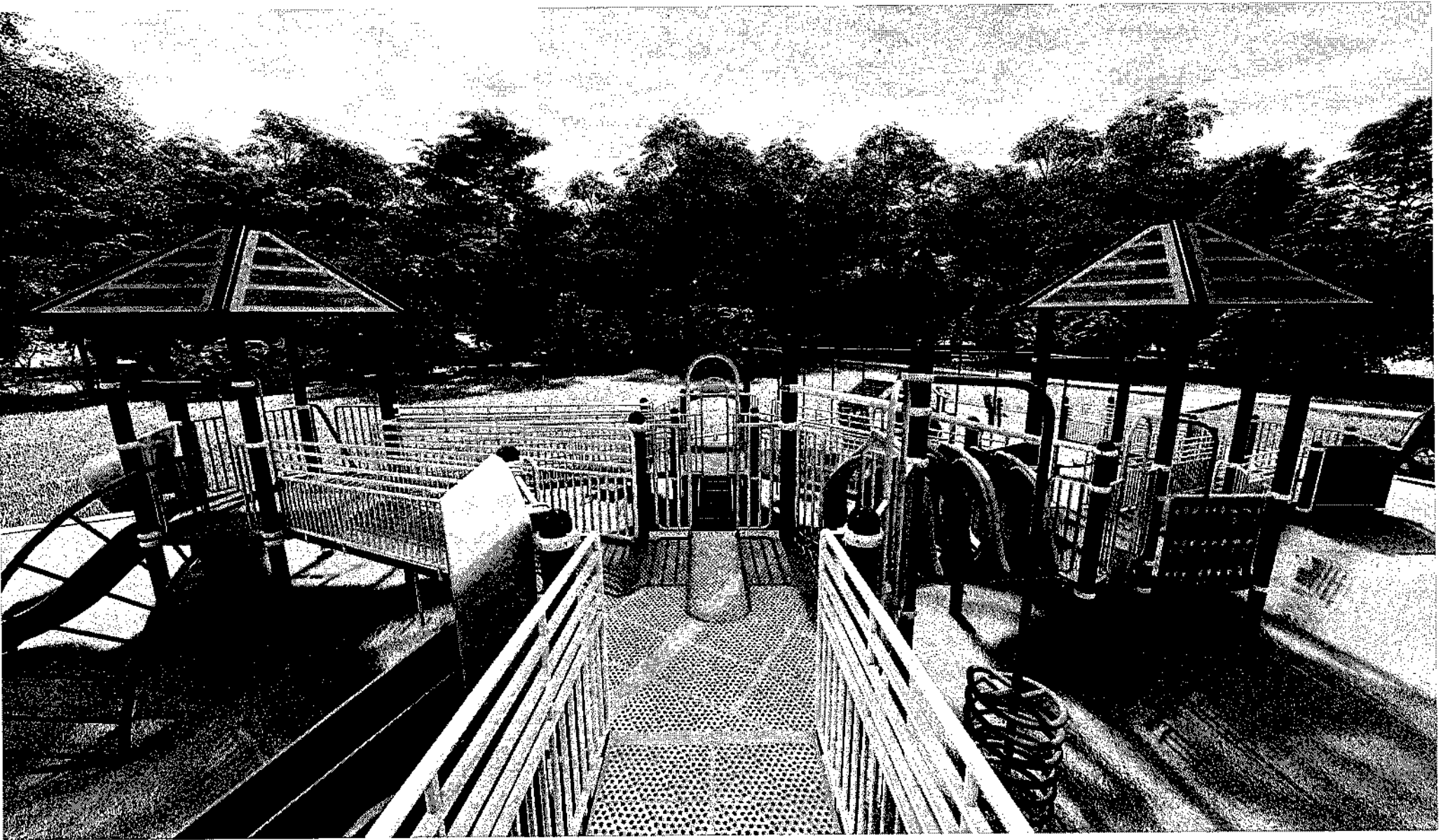

Deck



Green

Metals



Dark Brown



Forest Green



Lime



Beige

Plastics



Beige



Forest Green



Lime

Actual colors may vary. We work hard to ensure our renderings are as life-like as possible.

Licht Park
Warren, MI
R0061_45372684521





Deck



Green

Metals



Dark Brown



Forest Green



Lime



Beige

Plastics



Beige



Forest Green



Lime

Actual colors may vary. We work hard to ensure our renderings are as life-like as possible.

Licht Park
Warren, MI
R0061_45372684521



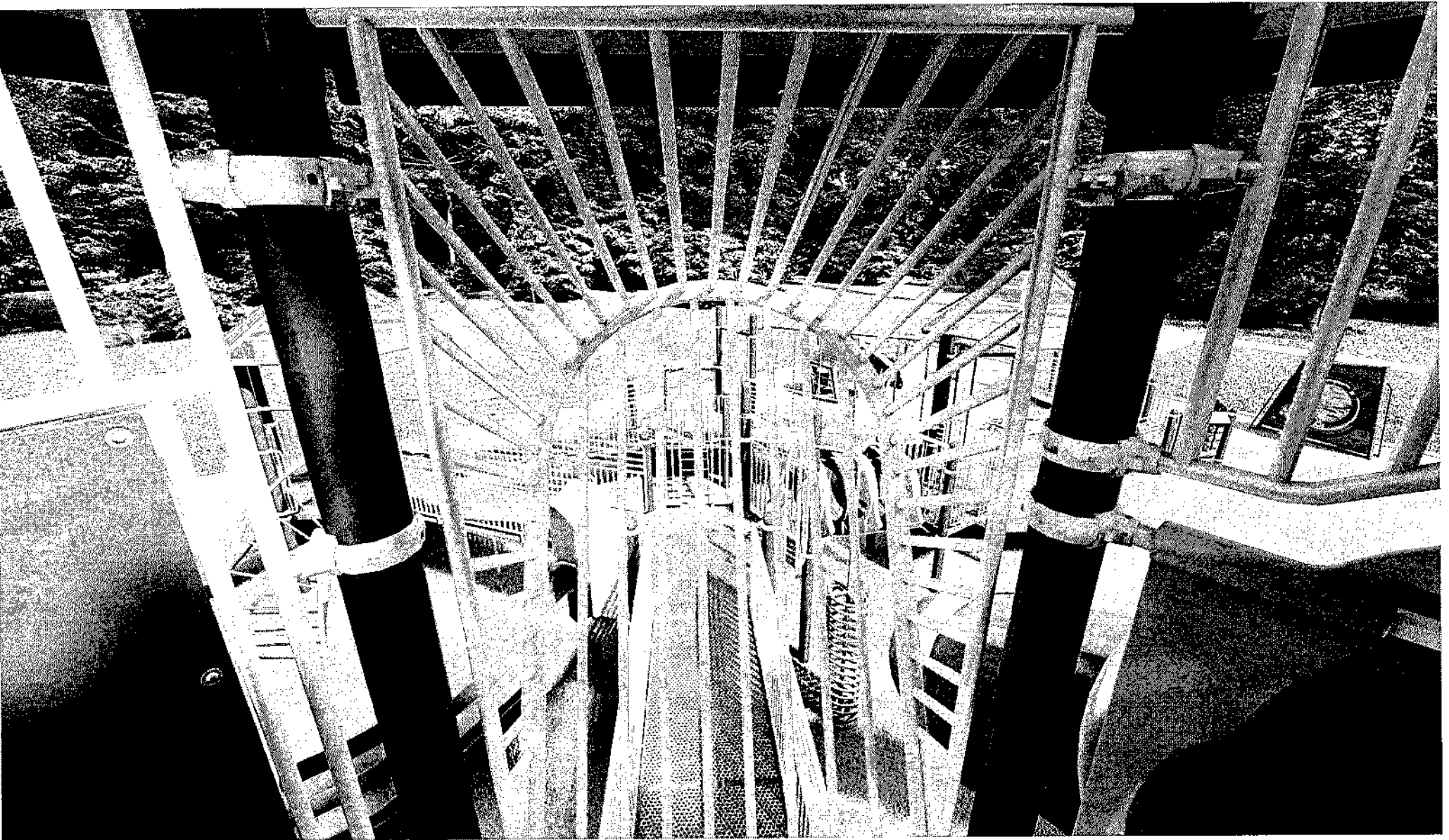

Deck



Green

Metals



Dark Brown



Forest Green



Lime



Beige

Plastics



Beige



Forest Green



Lime

Actual colors may vary. We work hard to ensure our renderings are as life-like as possible.

Licht Park
Warren, MI
R0061_45372684521



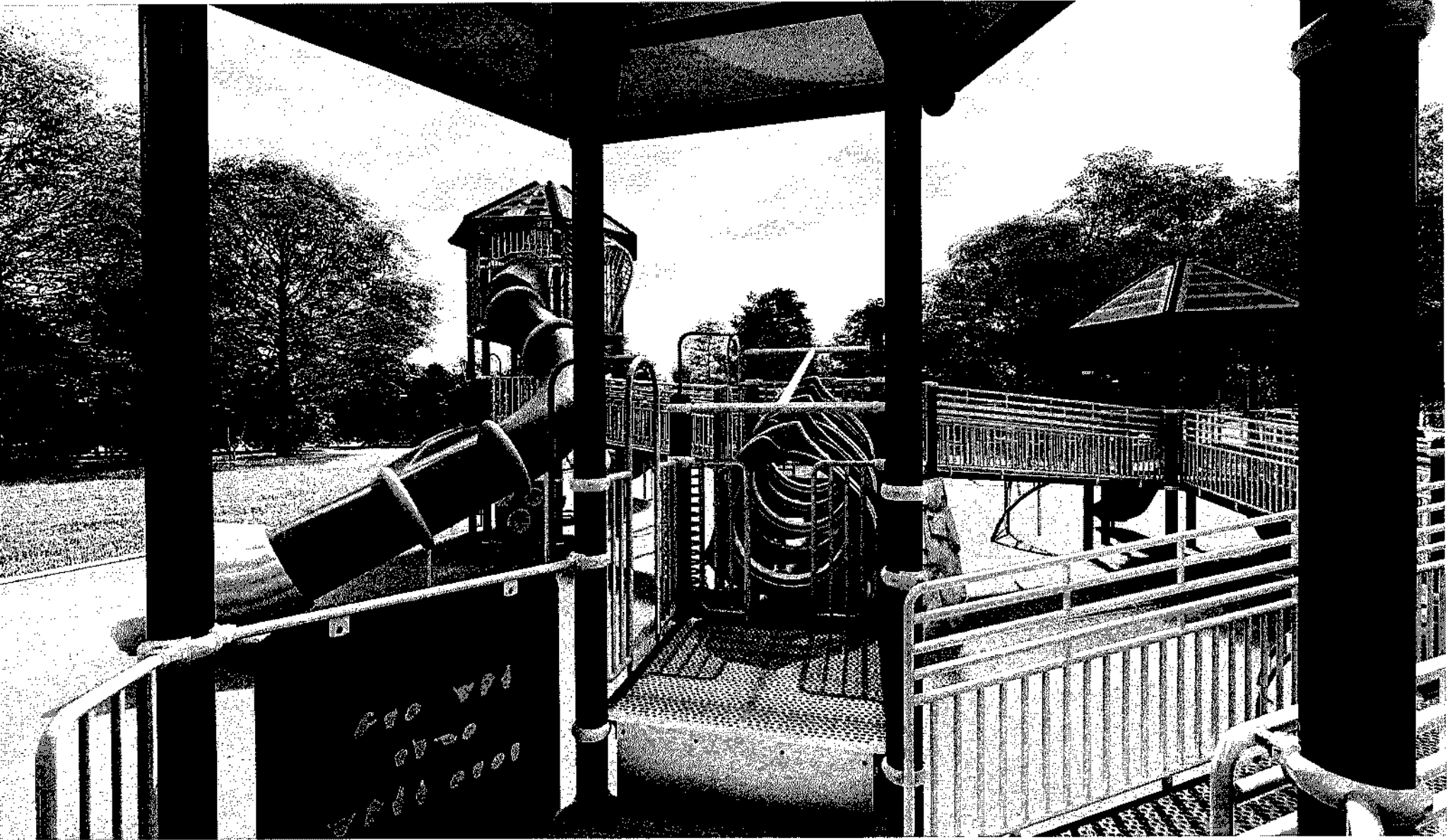

Deck



Green

Metals



Dark
Brown



Forest
Green



Lime



Beige

Plastics



Beige



Forest
Green



Lime

Actual colors may vary. We work hard to ensure our renderings are as life-like as possible.

Licht Park
Warren, MI
R0061_45372684521





Deck



Green

Metals



Dark Brown



Forest Green



Lime



Beige

Plastics



Beige



Forest Green



Lime

Actual colors may vary. We work hard to ensure our renderings are as life-like as possible.

Licht Park
Warren, MI
R0061_45372684521



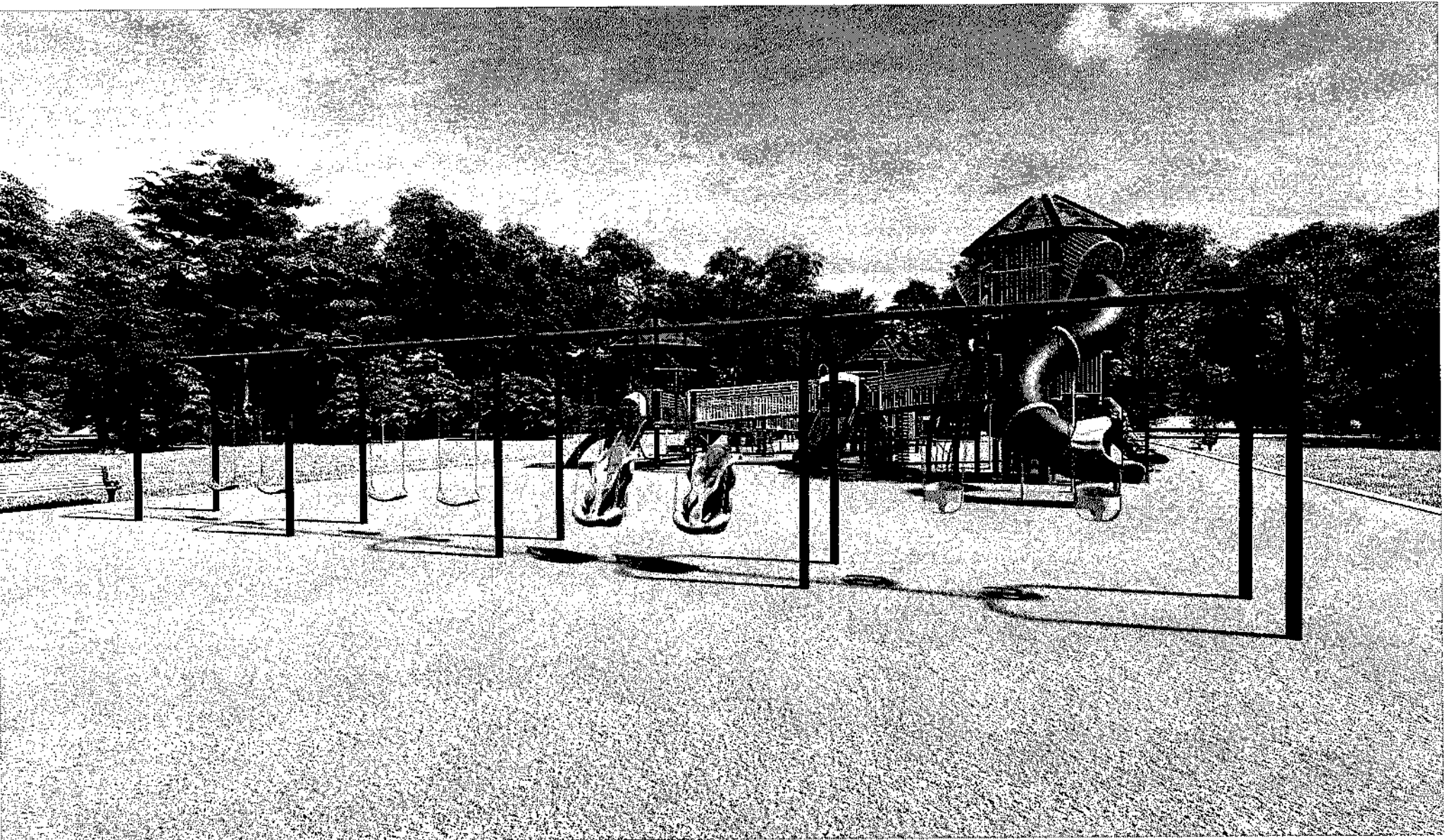

Deck



Green

Metals



Dark Brown



Forest Green



Lime



Beige

Plastics



Beige



Forest Green



Lime

Actual colors may vary. We work hard to ensure our renderings are as life-like as possible.

Licht Park
Warren, MI
R0061_45372684521

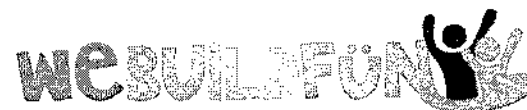



Deck



Green

Metals



Dark Brown



Forest Green



Lime



Beige

Plastics



Beige



Forest Green



Lime

Actual colors may vary. We work hard to ensure our renderings are as life-like as possible.

Licht Park
Warren, MI
R0061_45372684521

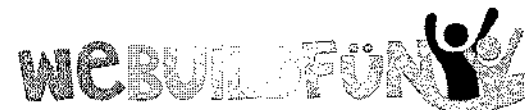

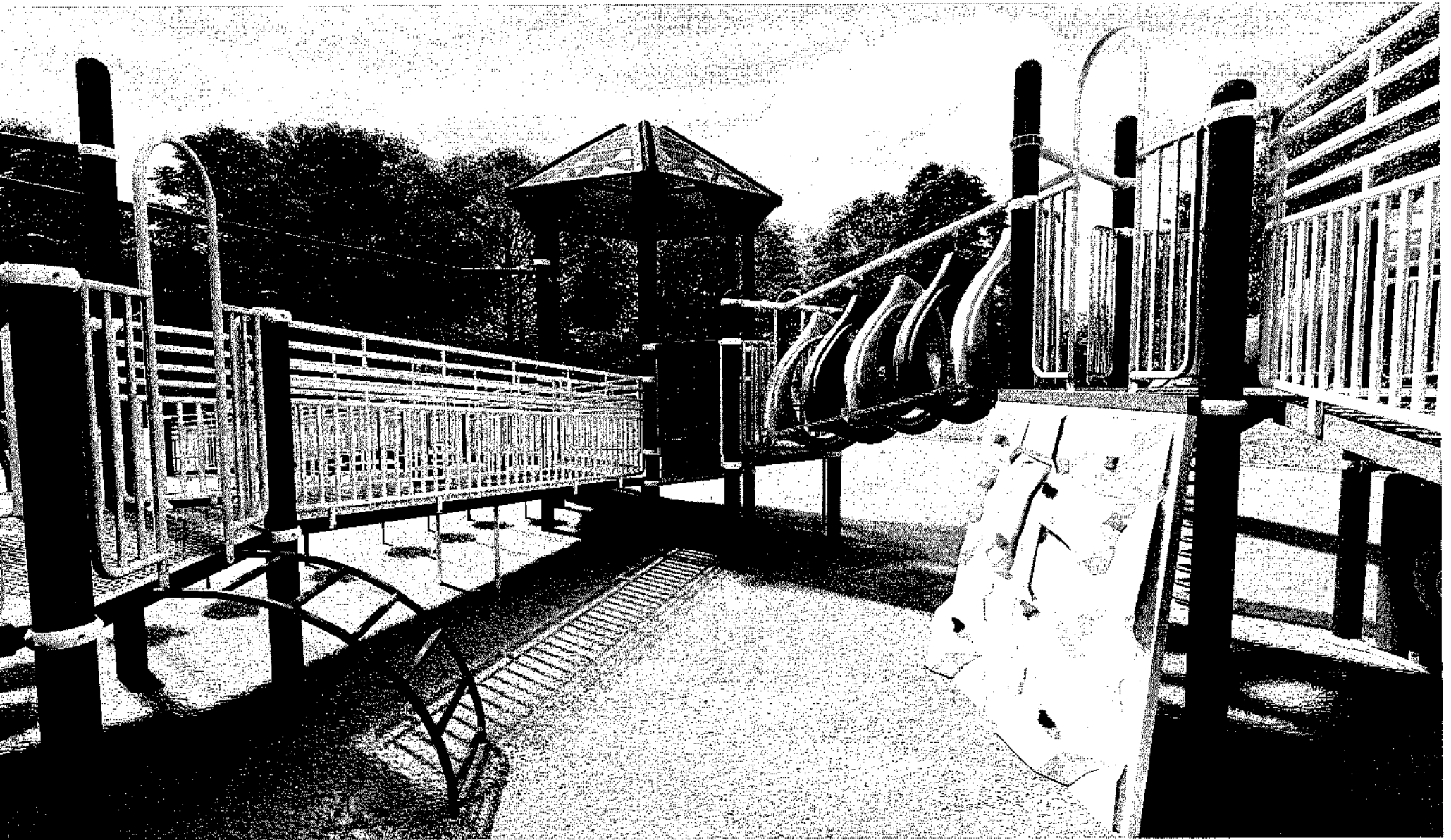

Deck



Green

Metals



Dark
Brown



Forest
Green



Lime



Beige

Plastics



Beige



Forest
Green



Lime

Actual colors may vary. We work hard to ensure our renderings are as life-like as possible.

Licht Park
Warren, MI
R0061_45372684521





PARKS AND RECREATION

5460 ARDEN
WARREN, MI 48093
(586) 268-8400

www.cityofwarren.org

May 2, 2024

Craig Treppa
City of Warren
One City Square
Suite 425
Warren, MI. 48093

Re: Licht Park Playground Equipment

Dear Mr. Treppa,

The Parks & Recreation Department is requesting to purchase new playground equipment for Licht Park. The new equipment will be replacing old equipment that is unsafe for use. The Parks & Recreation Department needs this new equipment to best suit the needs of the residents of Warren. The Department was diligent on searching for the proper type and manufacturer of this equipment. Attached is quote from webuildfun, Inc for a cost of \$597,469.90.

The City relied on Sourcewell Contract #010521-LTS customer id # 16557 for pricing. The funding for this new equipment is part of a Community Enhancement Grant and is available in account #9208-98462.

The Parks & Recreation Department recommends awarding the attached bid to webuildfun. Inc., PO Box 29, Allen, TX 75013. The total bid price of this equipment is \$597,469.90. The specifications of the equipment, the Sourcewell contract and bid is attached.

If you have any questions or require any additional information, please contact me.

Sincerely,

A handwritten signature in cursive script that reads "Anthony Casasanta".

**Anthony Casasanta,
Acting Director, Parks & Recreation**

RESOLUTION

Document No: TRI-W-1221

Product or Service: Furnish and Install Playground Equipment – Licht Park

Requesting Department: Parks & Recreation

At a Regular Meeting of the City Council of the City of Warren, County of Macomb, Michigan, held on _____, 2024 at 7 p.m. Local Time, in the Council Chamber at the Warren Community Center Auditorium, 5460 Arden, Warren, Michigan.

PRESENT: Councilmembers: _____

ABSENT: Councilmembers: _____

The following preamble and resolution were offered by Councilmember _____ and supported by Councilmember _____.

Pursuant to Section 2-344 of the Code of Ordinances, the City may either participate in, sponsor, conduct, or administer a cooperative purchasing agreement for the procurement of any supplies, equipment, goods, or services with one (1) or more public procurement units.

Upon performing a diligent inquiry, the Parks & Recreation (P&R) Director has determined that it is necessary in the interest of the P&R Department and the City to furnish and install new playground equipment at Licht Park utilizing the Sourcewell Cooperative Contract #010521-LTS, pursuant to cooperative purchasing, in a total amount of \$597,469.90. This project includes installation of new playground equipment, the complete removal of existing equipment and existing safety surfacing, installation of concrete curbing to surround the proposed play area, and the restoration of approximately 10,000 sf of playground area. The price also includes all delivery/freight charges.

The purchasing agent has conducted a review and concurs with the cooperative purchasing.

Funds are available in the following P&R Account: 208-9208-98462 and will be reimbursed from the Community Enhancement Grant.

IT IS RESOLVED, that the cooperative purchase with webuildfun, Inc., PO Box 29, Allen, TX 75013, utilizing the Sourcewell Cooperative Contract #010521-LTS with PlayPower, Inc., 11515 Vanstory Drive #100, Huntersville, NC 28078 (Miracle Recreation) is hereby approved by City Council in an amount of \$597,469.90. Webuild fun, Inc. is the representative for Miracle Recreation

IT IS FURTHER RESOLVED, that the City is approved to pay invoices for equipment in advance of installation services.

IT IS FURTHER RESOLVED, that the Purchasing Agent and/or Mayor and City Clerk are authorized to execute any such documents that are necessary for this approval consistent with the terms of the:

- X Cooperative Bid document
- Contract
- X Resolution

and in such form that meets with the satisfaction of the City Attorney if review is required.

AYES: Councilmembers: _____

NAYS: Councilmembers: _____

RESOLUTION DECLARED ADOPTED this ____ day of _____, 2024.

Mindy Moore
Secretary of the Council

CERTIFICATION

STATE OF MICHIGAN)
) SS.
COUNTY OF MACOMB)

I, Sonja Buffa, duly elected City Clerk for the City of Warren, Macomb County, Michigan, hereby certifies that the foregoing is a true and correct copy of the resolution adopted by the Council of the City of Warren at its meeting held on _____, 2024.

Sonja Buffa
City Clerk



CITY CONTROLLER'S OFFICE

ONE CITY SQUARE, SUITE 425
WARREN, MI 48093-5289
(586) 574-4600
FAX (586) 574-4614
www.cityofwarren.org

DATE: MAY 9, 2024
TO: MINDY MOORE, SECRETARY, WARREN CITY COUNCIL
SUBJECT: FILE TRI-W-1220 – RECOMMENDATION TO FURNISH AND INSTALL PLAYGROUND EQUIPMENT FOR VETERANS PARK UTILIZING OMNIA PARTNERS COOPERATIVE CONTRACT #2017001134

The Purchasing Division concurs with the Parks and Recreation (P&R) Department and recommends that City Council authorize the Furnish and Installation of Playground Equipment for Veterans Park from Playcore Wisconsin, Inc. dba Game Time, 150 PlayCore Drive SE, Fort Payne, AL 35967 C/O Sinclair Recreation, LLC, P.O. Box 1409 Holland, MI 49424 utilizing the Omnia Partners Cooperative Contract #2017001134, in a total amount not to exceed \$598,749.32.

The Parks and Recreation Department is seeking to replace existing playground equipment with new structures at the Veterans Park. Layouts of the play structures are attached for your review. Please see attached quotation to see what the project includes.

In addition to the playground equipment, the project will include the removal and disposal of the current playground equipment and timber edging, 12" of new compacted depth engineered wood fiber surfacing, installation of concrete curbing to surround the proposed play area, and poured in place surfacing.

Funds are available in the following Account: 208-9208-98462.

Respectfully Submitted,

Craig Treppa
Purchasing Agent

Approved By:	Signature	Date
Budget Director:		5/20/2024
Controller:		5/20/2024
MAYOR:		5/21/2024

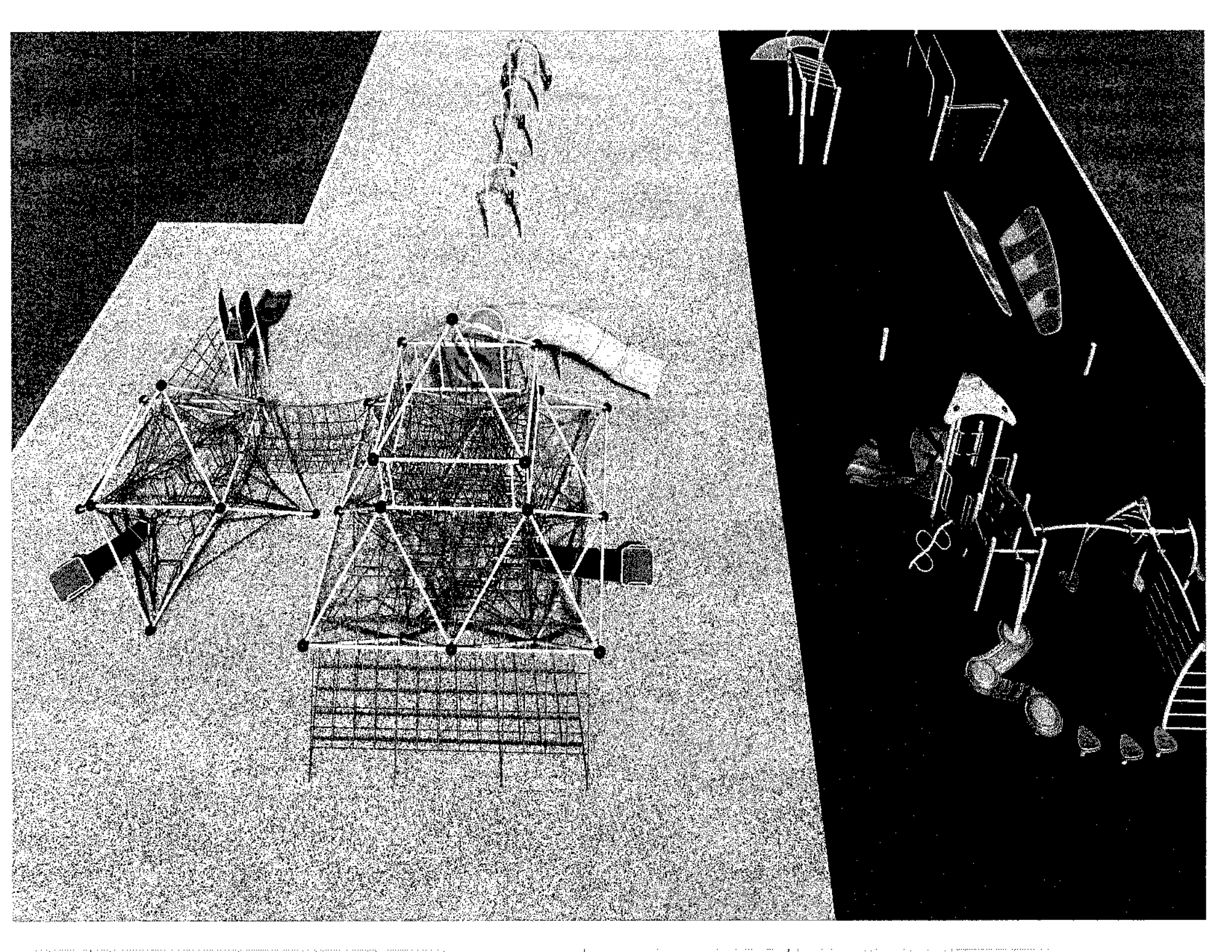

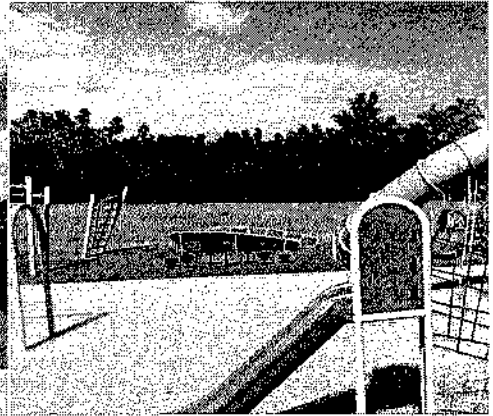
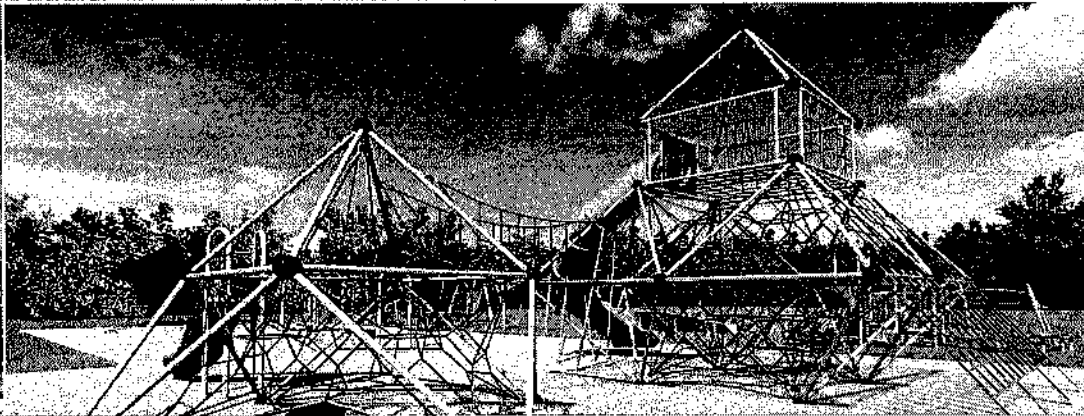
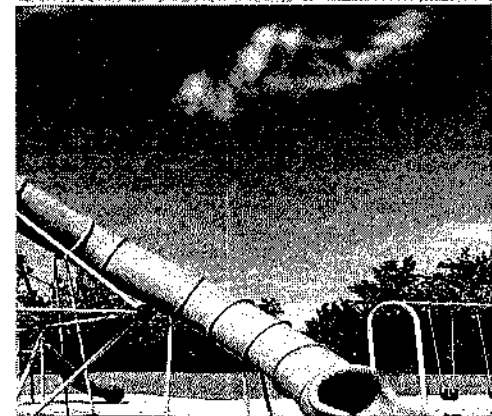
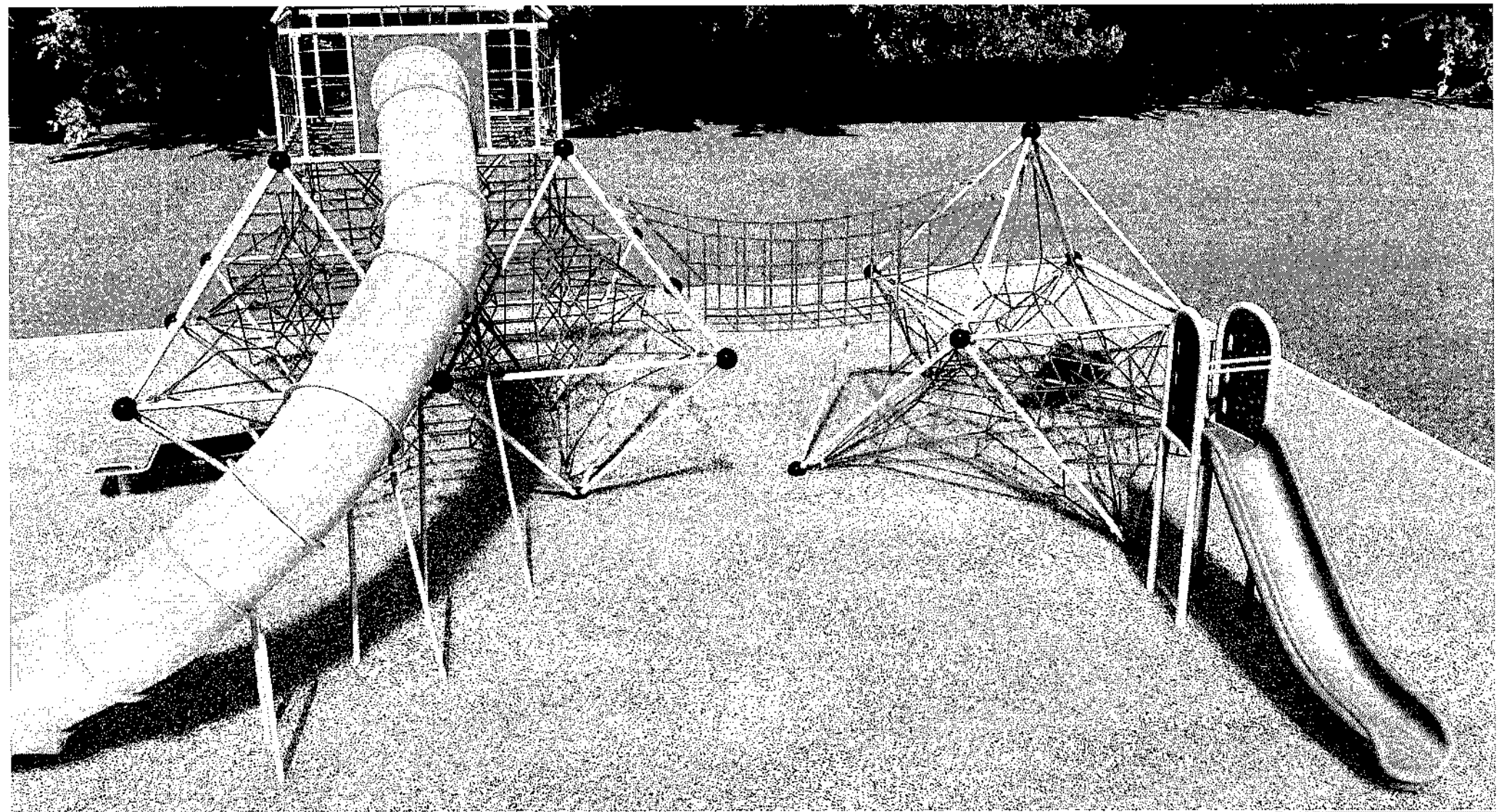

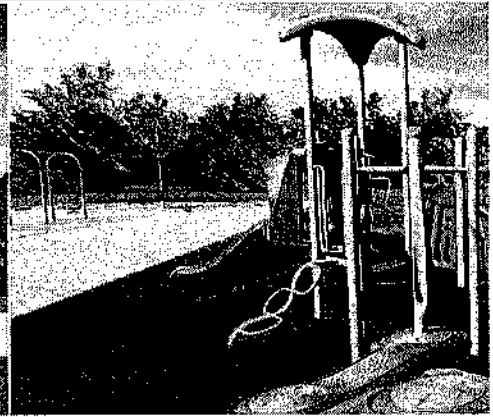

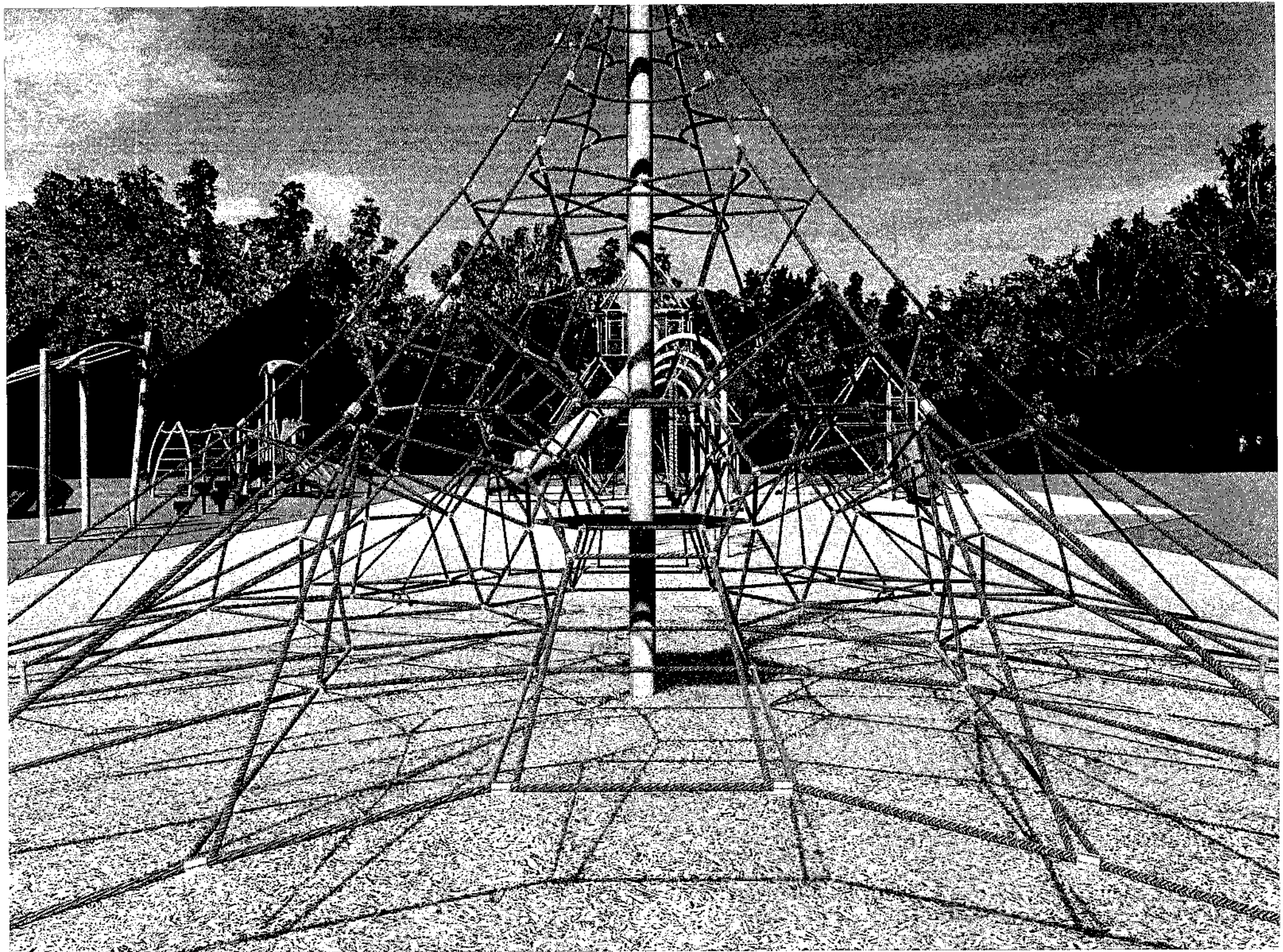

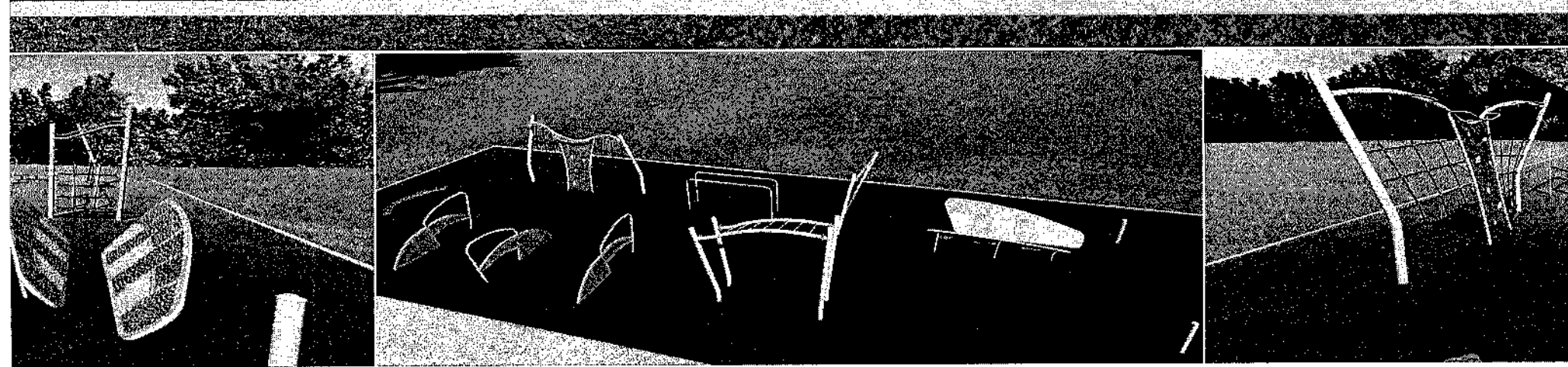
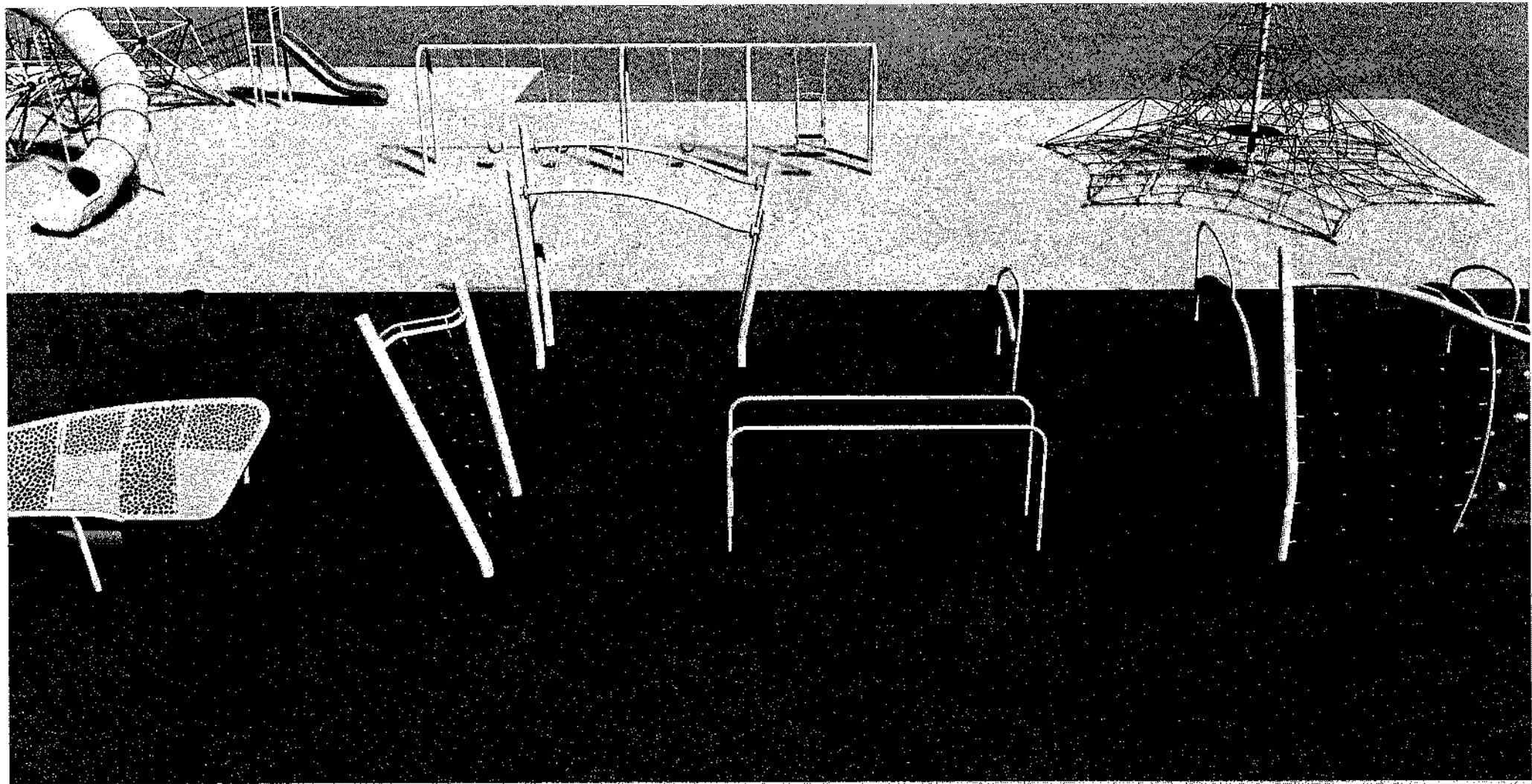

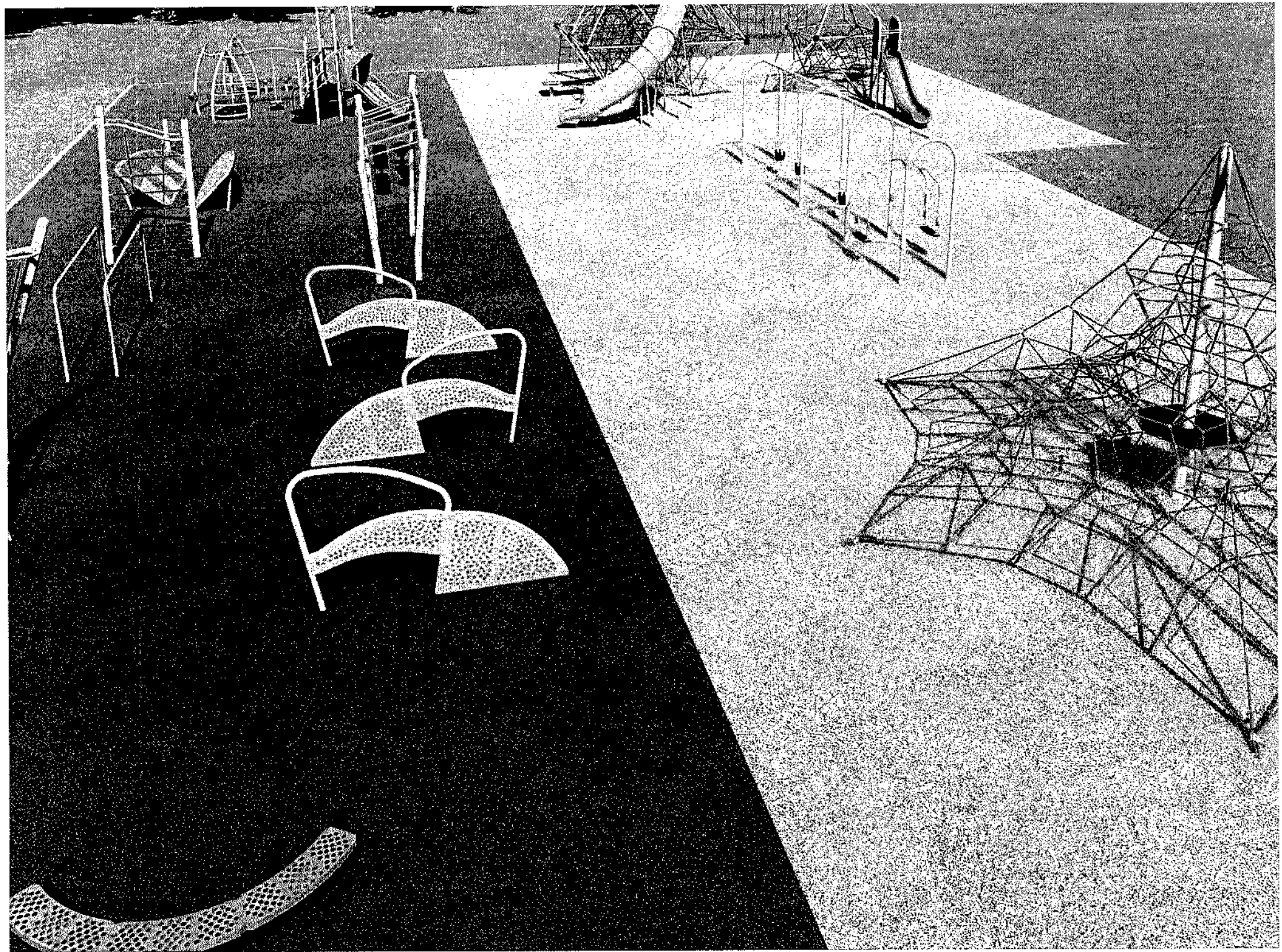



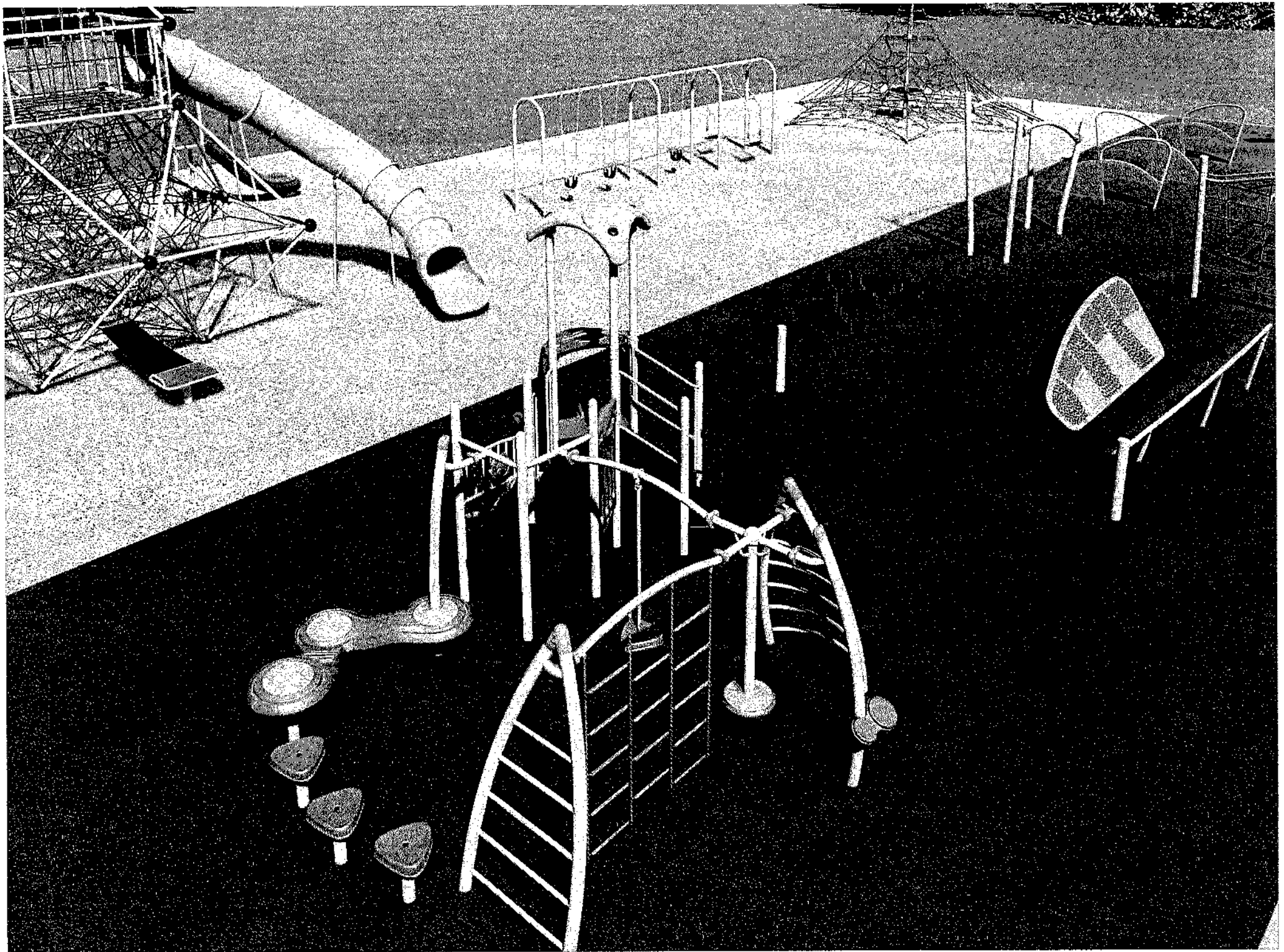

to be
timbers
as to be
restored

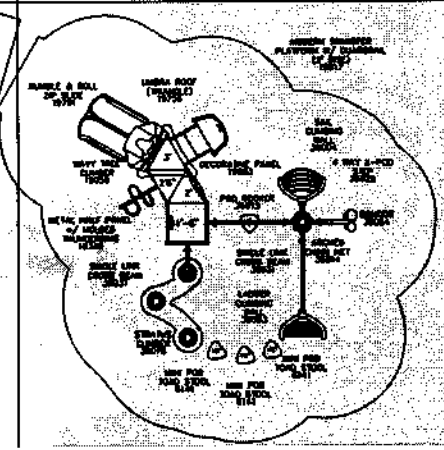
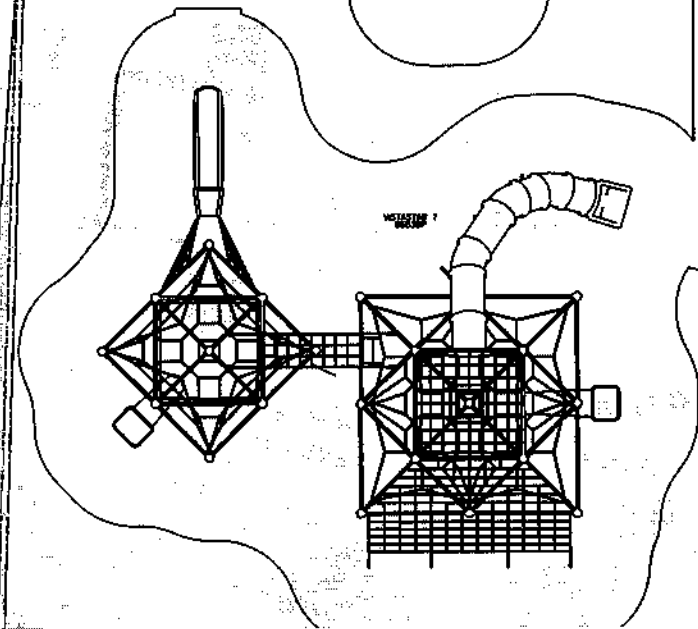
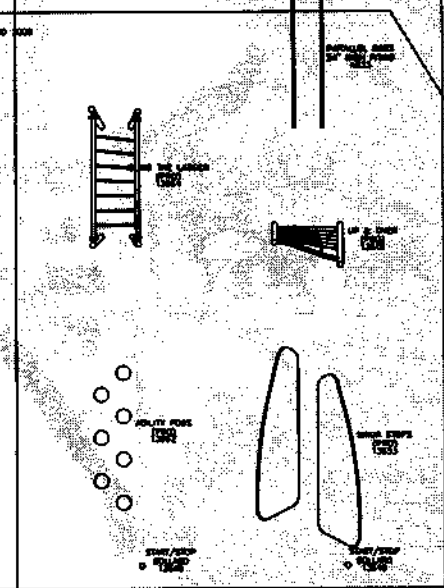
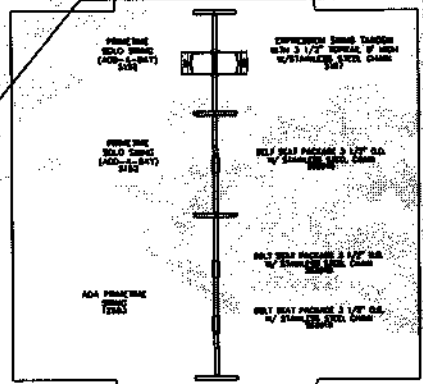
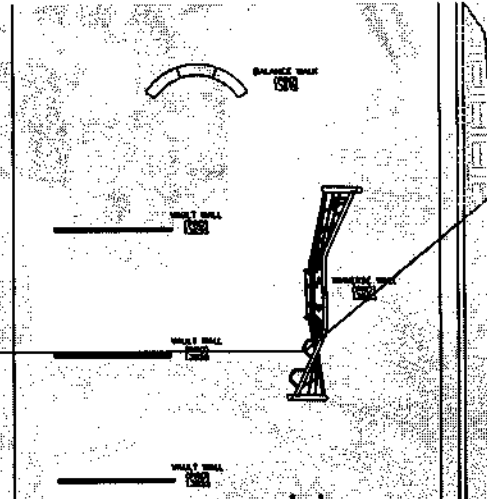
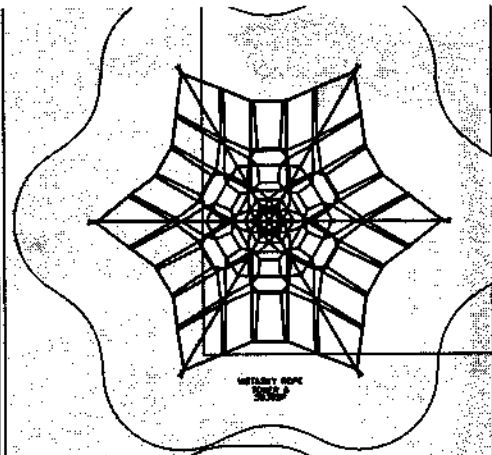

Existing
excavation
removed
backfill
by owner

PIP surface
proposed
and 2-5

STATE OF NORTH CAROLINA
COUNTY OF MECKLENBURG

**FIFTEENTH AMENDMENT TO THE AGREEMENT TO PROVIDE
PLAYGROUND AND OUTDOOR FITNESS EQUIPMENT, SITE ACCESSORIES, SURFACING,
AND RELATED PRODUCTS AND SERVICES**

THIS FIFTEENTH AMENDMENT TO THE AGREEMENT TO PROVIDE PLAYGROUND AND OUTDOOR FITNESS EQUIPMENT, SITE ACCESSORIES, SURFACING, AND RELATED PRODUCTS AND SERVICES (this "Fifteenth Amendment") is made and entered into this 22 of December 2023, by and between Playcore Wisconsin, Inc., dba GameTime an Alabama corporation doing business in North Carolina (the "Company"), and the City of Charlotte, a North Carolina municipal corporation (the "City").

Statement of Background and Intent

- A. The City of Charlotte and the Company entered into an Agreement for Playground and Outdoor Fitness Equipment, Site Accessories, Surfacing, and Related Products and Services dated July 1, 2017 (the "Contract") pursuant to which the Company agreed to provide Playground and Outdoor Fitness Equipment, Site Accessories, Surfacing, and Related Products and Services for the City of Charlotte.
- B. The parties amended the Contract on January 1, 2018, to incorporate unit price adjustments and freight rate adjustments.
- C. The parties amended the Contract on July 1, 2018, to incorporate unit price adjustments due to tariffs on steel and aluminum.
- D. The parties amended the Contract on September 1, 2018, to incorporate federal contract terms and conditions.
- E. The parties amended the Contract on January 1, 2019, to incorporate unit price adjustments and freight rate adjustments.
- F. The parties amended the Contract on April 1, 2019, to incorporate new products and pricing.
- G. The parties amended the Contract on January 1, 2020, to incorporate unit price adjustments and freight rate adjustments.
- H. The parties amended the Contract on January 1, 2021, to incorporate new products, unit price adjustments, and freight rate adjustments.
- I. The parties amended the Contract on March 16, 2021, to incorporate a █% material surcharge.
- J. The parties amended the Contract on May 17, 2021, to incorporate a █% material surcharge.
- K. The parties amended the Contract on July 14, 2021, to incorporate a █% material surcharge.
- L. The parties amended the Contract on December 1, 2021, to add new Products and Services and to incorporate the 2022 Master Price List and Freight Rate Schedule.

- M. The parties amended the Contract on July 1, 2022, to extend the Term of the Contract by the first of two (2) two-year renewal terms and to incorporate certain other changes.
- N. The parties amended the Contract on December 5, 2022, to add new Products and Services and to incorporate the 2023 Master Price List and Freight Rate Schedule, the 2022 Network of Distributors, and incorporate certain other changes.
- O. The parties amended the Contract to extend the Term of the Contract by the second of two (2) two-year renewal terms and to incorporate certain other changes.
- P. The parties now desire to amend the Contract to add new Products and Services and incorporate the 2024 Master Price List and Freight Rate Schedule and incorporate certain other changes.

NOW, THEREFORE, in consideration of the mutual covenants and agreements contained herein, the parties hereby agree to the following:

AGREEMENT

- 1. The terms of the Contract are restated by and incorporated into this Fifteenth Amendment by reference.
- 2. Defined terms used in this Fifteenth Amendment shall have the same meaning as are assigned to such terms in the Contract.
- 3. The Pricing Sheets in Exhibit A of the Contract are hereby replaced in their entirety to the adjustments in the 2024 Master Price List which are attached hereto as Exhibit A.2.
- 4. The Freight Rate Schedules in Exhibit D of the Contract are hereby replaced in their entirety to the adjustments in the 2024 GameTime OMNIA Contract Freight Rates which are attached hereto as Exhibit D.2.
- 5. Except to the extent specifically provided above, this amendment shall not be interpreted or construed as waiving any rights, obligations, remedies, or claims the parties may otherwise have under the Contract.
- 6. In all other respects and except as modified herein, the terms of the Contract shall remain in force and effect.

[Signature Page Follows]

IN WITNESS WHEREOF, and in acknowledgment that the parties hereto have read and understood each and every provision hereof, the parties have caused this Fifteenth Amendment to be executed as of the date first written above.

PLAYCORE WISCONSIN INC.
DBA GAMETIME:

CITY OF CHARLOTTE:
CITY MANAGER'S OFFICE

BY: 
(Signature)

BY: See Attachment Below
(Signature)

PRINT NAME: Clint Whiteside

PRINT NAME: _____

TITLE: Director of Sales

TITLE: _____

DATE: 12/18/2023

DATE: _____



GameTime c/o Sinclair Recreation
 176 E Lakewood Blvd
 Holland, MI 49424
 Ph: 800-444-4954
 Fax: 616-392-8634

05/07/2024
 Quote #
 105639-01-02

City of Warren - 2024 Playground Proposal - Veteran's Park - Prevailing Wages

City of Warren
 Attn: Anthony Casasanta
 Purchasing Department, One City Square, Ste 425
 Warren, MI 48093
 Phone: 586-258-2008

Ship to Zip 48093

Quantity	Part #	Description	Unit Price	Amount
1	INSTALL	GT-Impax - Removal and disposal of existing equipment and timber edging- Does not include restoration or backfilling of previous playground area not included in current proposal.	\$22,800.00	\$22,800.00
5695	EWF	GT-Impax - 12" Compacted depth engineered wood fiber surfacing, blown in	\$3.00	\$17,085.00
11650	INSTALL	GT-Impax - Excavation of area to a depth of 9" for new PIP surfacing and 12" for EWF area- Does not include restoration or backfilling of previous playground area not included in current proposal.	\$2.95	\$34,367.50
422	INSTALL	GT-Impax - Installation of concrete curbing to surround proposed play area	\$90.00	\$37,980.00
4385	PIP	GT-Impax - Poured in Place Surfacing, 50% standard color / 50% black, 4.75" for a 10' CFH- Price includes supply and installation of 4" crushed stone subbase and additional square footage where EWF meets PIP surfacing Does NOT include site security while PIP material cures.	\$30.00	\$131,550.00
1	INSTALL	GT-Impax - Installation of new GameTime equipment into proposed area.	\$137,500.00	\$137,500.00
1	13673	GameTime - Pro 2000- Does not include any scoring or scoreboard or electrical work. Start/stop bollards not to be installed.	\$78,993.00	\$78,993.00
1	RDU	GameTime - 2-5 Unit	\$35,243.00	\$35,243.00
		(3) 6141 -- Mini Pod Toad Stool		
		(2) G12023 -- 3 1/2" Uprt Ass'Y Galv 8'		
		(4) G12024 -- 3 1/2" Uprt Ass'Y Galv 9'		
		(3) G12068 -- 3 1/2" Uprt Ass'Y Galv 13'		
		(1) 18200 -- 36" Sq Punched Deck P/T 1.3125		
		(3) 18201 -- 36" Tri Punched Deck P/T		
		(1) 19001 -- Entry Way		
		(1) 19003 -- Decorative Panel		
		(1) 19059 -- Wavy Tree (2'-6" & 3')		
		(1) 19349 -- Metal Half Panel W/ Thundering		
		(1) 19756 -- Umbra Triangle Roof		
		(3) 19762 -- Umbra Roof Plug		
		(1) 19917 -- Modern Transfer w/Guardrail 2' Rise		
		(7) 26094 -- Triangular Shroud		
		(1) 36003 -- Ladder Climbing Wall		



GameTime c/o Sinclair Recreation
 176 E Lakewood Blvd
 Holland, MI 49424
 Ph: 800-444-4954
 Fax: 616-392-8634

05/07/2024
 Quote #
 105639-01-02

City of Warren - 2024 Playground Proposal - Veteran's Park - Prevailing Wages

Quantity	Part #	Description	Unit Price	Amount
		(1) 36004 – Sail Climbing Wall		
		(1) 36014 – Arched Chain Net Link		
		(1) 36015 – Pod Rocker		
		(1) 36025 – 4 Way X-Pod Step		
		(2) 36031 – Single Link Cross Beam Primetime 36		
		(1) 36064 – Bongos		
		(1) 36076 – Stratus Climber		
		(1) 19791 – Dbl Rumble & Roll 2'-6"/3'		
1	6683SP	GameTime - VistaStar 7	\$118,215.00	\$118,215.00
1	5939SP	GameTime - VistaSky Rope Tower 8	\$16,024.00	\$16,024.00
1	RDU	GameTime - Swings with Seats	\$8,052.00	\$8,052.00
		(3) SS8910 -- Belt Seat 3 1/2" /8' W/Clevis		
		(1) 5167 -- Expression Swing Tandem		
		(1) 12583 – Ada Primetime Swing Frame, 3 1/2" Od		
		(2) 5152 -- Pt Solo Add-A-Bay 3 1/2" X 8'		
Contract: OMNIA #2017001134			Sub Total	\$637,809.50
			Discount	(\$45,945.18)
			Freight	\$6,885.00
			Total	\$598,749.32

This quotation is subject to policies in the current GameTime Playground Catalog and the following terms and conditions. Our quotation is based on shipment of all items at one time to a single destination, unless noted, and changes are subject to price adjustment. Purchases to be supported by your written purchase order made out to GAMETIME C/O SINCLAIR RECREATION. **A 2.5% PROCESSING FEE WILL BE ADDED TO ALL ORDERS PAID VIA CREDIT CARD.**

Pricing: f.o.b. factory, firm for 30 days from date of quotation unless otherwise noted on quotation. Sales tax will be added at time of invoicing unless a tax exemption certificate is provided at time of order entry.

NET 45 CJT

Payment terms: ~~NET 30~~ days for tax supported governmental agencies. A 1.5% per month finance charge will be imposed on all past due accounts. Equipment shall be invoiced separately from other services and shall be payable in advance of those services and project completion. Retainage not accepted.

Shipment: Order shall ship within 10-12 weeks after GameTime's receipt and acceptance of your purchase order, color selections, approved submittals, and receipt of deposit, if required.

Shipment: Vistarope Net shall ship within 18-36 weeks after GameTime's receipt and acceptance of your purchase order, color selections, approved submittals, and receipt of deposit, if required. Port Congestion and transit time affect overall lead time and are impossible to predict.





GameTime c/o Sinclair Recreation
 176 E Lakewood Blvd
 Holland, MI 49424
 Ph: 800-444-4954
 Fax: 616-392-8634

05/07/2024
 Quote #
 105639-01-02

City of Warren - 2024 Playground Proposal - Veteran's Park - Prevailing Wages

Installation: Shall be by a Certified GameTime Installer. Customer shall be responsible for scheduling coordination and site preparation. Site should be level and permit installation equipment access. Purchaser shall be responsible for unknown conditions such as buried utilities, tree stumps, bedrock or any concealed materials or conditions that may result in additional labor or material costs. Payment terms for installation is Net 10 Days.

NOTE: PRICING DOES INCLUDE PREVAILING WAGE RATES FOR THE STATE OF MICHIGAN. THERE WILL BE A BACKCHARGE FOR THE INSTALLATION TO BE DONE THROUGH FELT, PEASTONE, SURFACING, OR WOODCHIPS, UNLESS SPECIFICALLY LISTED IN ABOVE QUOTE.

Submittals: Our design proposal reflects the spirit and intent of the project plans and specifications. While some variations may exist between our quotation and the project design, the differences do not materially affect the intended use. GameTime designs and specifications are unique and not intended to be identical in all respects to other manufacturers. We shall submit for review and approval by the owner's representative detailed drawings depicting the equipment to be furnished accompanied by specifications describing materials. Once approved, these drawings and specifications shall constitute the final documents for the project and shall take precedence over all other requirements.

Exclusions: Unless specifically included, this quotation excludes all site work and landscaping; removal of existing equipment; acceptance of equipment and off-loading; storage of goods prior to installation; equipment assembly and installation; safety surfacing; borders, drainage provisions, or any local/municipal permits or paperwork that may be required.



GameTime c/o Sinclair Recreation
176 E Lakewood Blvd
Holland, MI 49424
Ph: 800-444-4954
Fax: 616-392-8634

05/07/2024
Quote #
105639-01-02

City of Warren - 2024 Playground Proposal - Veteran's Park - Prevailing Wages

Acceptance of quotation:

Accepted By (printed): _____

Signature: _____

Title: _____

Facsimile: _____

Email: _____

P.O. No: _____

Please make P.O.s out to GameTime C/O Sinclair Recreation

Date: _____

Phone: _____

Purchase Amount: \$598,749.32

REQUIRED ORDER INFORMATION:

Bill To: _____

Contact: _____

Address: _____

Address: _____

City, State, Zip: _____

Tel: _____

(For Accounts Payable)

Email: _____

Ship To: _____

Contact: _____

Address: _____

Address: _____

City, State, Zip: _____

Tel: _____

(To call before delivery)

Email: _____

COLOR SELECTIONS: _____

SALES TAX EXEMPTION CERTIFICATE #: _____ (PLEASE PROVIDE A COPY OF CERTIFICATE)

NOTE: IF INSTALLATION IS BEING QUOTED, THERE WILL BE A BACKCHARGE FOR THE INSTALLATION TO BE DONE THROUGH FELT, PEASTONE, SURFACING, OR WOODCHIPS. PRICING VALID FOR 30 DAYS FROM THE DATE OF QUOTATION UNLESS OTHERWISE NOTED. ANY MODIFICATIONS TO AN ACCEPTED QUOTATION MUST BE DOCUMENTED IN WRITING OR WITH A NEW OR SEPARATE QUOTE. VERBAL MODIFICATIONS TO PREVIOUSLY SIGNED QUOTES WILL NOT BE ACCEPTED.

Quote prepared by: Alison Wfegerink



PARKS AND RECREATION

5460 ARDEN
WARREN, MI 48093
(586) 268-8400
www.cityofwarren.org

May 8, 2024

Craig Treppa
City of Warren
One City Square
Suite 425
Warren, MI. 48093

Re: Veterans Park Playground Equipment

Dear Mr. Treppa,

The Parks & Recreation Department is requesting to purchase new playground equipment for Veterans Park. The new equipment will be replacing old equipment that is unsafe for use. The Parks & Recreation Department needs this new equipment to best suit the needs of the residents of Warren. The Department was diligent on searching for the proper type and manufacturer of this equipment. Attached is quote #105639-01-01 from Gametime, Inc for a cost of \$598,749.32.

~~The City relied on Omnia Contract #2017001134 amendment #5, customer id # 121531 for pricing. The funding for this new equipment is part of a Community Enhancement Grant and is available in account #9208-98462.~~

The Parks & Recreation Department recommends awarding the attached bid to Gametime. Inc., 150 PlayCore Drive SE, Fort Payne, AL 35967. The total bid price of this equipment is \$598,749.32. The specifications of the equipment, the Omnia contract and bid is attached.

If you have any questions or require any additional information, please contact me.

Sincerely,

A handwritten signature in black ink that reads "Anthony Casasanta".

**Anthony Casasanta,
Acting Director, Parks & Recreation**

RESOLUTION

Document No: TRI-W-1220

Product or Service: Furnish and Install Playground Equipment – Veterans Park

Requesting Department: Parks & Recreation

At a Regular Meeting of the City Council of the City of Warren, County of Macomb, Michigan, held on _____, 2024 at 7 p.m. Local Time, in the Council Chamber at the Warren Community Center Auditorium, 5460 Arden, Warren, Michigan.

PRESENT: Councilmembers: _____

ABSENT: Councilmembers: _____

The following preamble and resolution were offered by Councilmember _____ and supported by Councilmember _____.

Pursuant to Section 2-344 of the Code of Ordinances, the City may either participate in, sponsor, conduct, or administer a cooperative purchasing agreement for the procurement of any supplies, equipment, goods, or services with one (1) or more public procurement units.

Upon performing a diligent inquiry, the Parks & Recreation (P&R) Director has determined that it is necessary in the interest of the P&R Department and the City to furnish and install new playground equipment at Veterans Park utilizing the Omnia Partners Cooperative Contract #2017001134, pursuant to cooperative purchasing, in a total amount of \$598,749.32. This project includes the complete removal of existing equipment and timber edging, the installation of 12" of new compacted depth engineered wood fiber surfacing, installation of concrete curbing to surround the proposed play area, and poured in place surfacing, along with the complete setup of new equipment, and all delivery/freight charges.

The purchasing agent has conducted a review and concurs with the cooperative purchasing.

Funds are available in the following P&R Account: 208-9208-98462.

IT IS RESOLVED, that the cooperative purchase with Playcore Wisconsin, Inc. dba Game Time, 150 PlayCore Drive SE, Fort Payne, AL 35967 C/O Sinclair Recreation, LLC, P.O. Box 1409 Holland, MI 49424 is hereby approved by City Council in an amount of \$598,749.32.

IT IS FURTHER RESOLVED, that the City is approved to pay invoices for equipment in advance of installation services.

IT IS FURTHER RESOLVED, that the Purchasing Agent and/or Mayor and City Clerk are authorized to execute any such documents that are necessary for this approval consistent with the terms of the:

- Cooperative Bid document
- Contract
- Resolution

and in such form that meets with the satisfaction of the City Attorney if review is required.

AYES: Councilmembers: _____

NAYS: Councilmembers: _____

RESOLUTION DECLARED ADOPTED this ____ day of _____, 2024.

Mindy Moore
Secretary of the Council



**PUBLIC SERVICE DEPARTMENT
ENGINEERING DIVISION**
One City Square, Suite 300
Warren, Michigan 48093-2390
(586) 759-9300
Fax (586) 759-9318
www.cityofwarren.org

TO: Ms. Mindy Moore, City Council Secretary

DATE: May 15, 2024

RE: CONSIDERATION AND ADOPTION OF RESOLUTION to approve Contract Modification No. 2 and FINAL to City Contract W-22-738, Toepfer Road Water Main Replacement (Hoover Rd. to Groesbeck Hwy.), increasing the current contract amount by \$102,824.02 resulting in a Final contract amount of \$1,784,497.51; and to issue Payment No. 7 and Final in the amount of \$177,675.80 to Aielli Construction Company.

Attached hereto is a copy of the proposed Contract Modification No. 2 and Final to the City Contract W-22-738, Toepfer Road Water Main Replacement (Hoover Rd. to Groesbeck Hwy.).

The contract modification is for the final adjustment of quantities and balancing the pay items to as-constructed quantities, resulting in an increase from the amended contract amount by \$102,824.02 resulting in a final contract amount of \$1,784,497.51.

The total amount of the requested additional funding in the attached Contract Modification No. 2 and Final to the City Contract W-22-738, Toepfer Road Water Main Replacement (Hoover Rd. to Groesbeck Hwy.) is \$102,824.02 resulting in a final contract amount of \$1,784,497.51.

The Engineering Division recommends that the Warren City Council approve the Contract Modification No. 2 and Final to the City Contract W-22-738, Toepfer Water Main Replacement (Hoover Rd. to Groesbeck Hwy.) as presented in the attached documents. Availability of funding has been reviewed by the Budget Director as indicated in the attached resolution.

Please place this item on the first available City Council agenda for consideration. If you have any questions regarding this matter, I can be reached in my office at (586) 759-9306.

Sincerely,

Read and Concurred:

Read and Concurred:

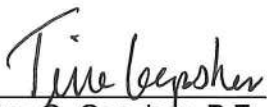
Tina G. Gapshes, P.E.
City Engineer



David Muzzarelli
Public Service Director

Kristina Battle
Budget Director

Approved as to Form:

Recommended to Council:

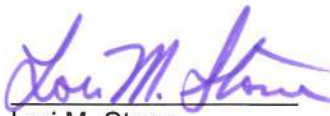
Mary Michaels
Acting City Attorney

Lori M. Stone
Mayor



**PUBLIC SERVICE DEPARTMENT
ENGINEERING DIVISION**

One City Square, Suite 300
Warren, MI 48093
P: (586) 759-9300
F: (586) 759-9318
www.cityowarren.org

CONTRACT MODIFICATION

DATE: May 15, 2024
CONTRACT: W-22-738 Toepfer Road Water Main Replacement
(Hoover Rd. to Groesbeck Hwy.)
MODIFICATION NO.: 2 and Final
TO: Aielli Construction Company
47742 Van Dyke Ave
Shelby Township, MI 48317

NECESSITY FOR REVISION:

The contract modification is for the final adjustment of quantities and balancing the pay items to as-constructed quantities, resulting in an increase from the amended contract amount by \$102,824.02 resulting in a final contract amount of \$1,784,497.51.

The Contractor will be held to furnish all materials and labor required for the completion of the work described herein, including all items incidental thereto or necessary to complete the work, even though not specifically mentioned.

This document shall become an amendment to the Contract, and all provisions of the Contract will apply to all work performed. The total sum of \$102,824.02 is hereby added to the current amended contract amount of \$1,681,673.49, resulting in a final contract amount of \$1,784,497.51.

The above shall be effective upon approval of the Mayor and City Council.

Accepted by:  Paolo Iacobacci, Secretary Date: 5/15/2024
Aielli Construction Company (Contractor)

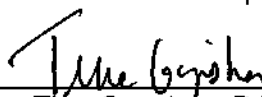
Recommended by:  Date: 5-15-24
Tina Gapshes, P.E., City Engineer

Approved by: _____ Warren City Council Date: _____

Approved by: _____ Date: _____
Lori M. Stone, Mayor

Approved by: _____ Date: _____
Sonja Buffa, City Clerk



City Contract W-22-738
 Toepfer Road Watermain Replacement (Heaver Rd. to Groesbeck Hwy.)

Engineering Division
 FINAL ADJUSTMENT OF QUANTITIES

Contractor: Aielli Construction Company
 Address: 47742 Van Dyke Ave
 City: Shelby Township, MI 48317

ITEM NO.	DESCRIPTION	ORIGINAL BID QUANTITY	UNITS	CONTRACT UNIT PRICE	ORIGINAL BID AMOUNT	FINAL CONTRACT QUANTITY	FINAL CONTRACT AMOUNT	CHANGE CONTRACT QUANTITY	CHANGE CONTRACT AMOUNT
1	Pavement, Rem	2261	Syd	\$ 8.94	\$20,213.34	3166.05	\$28,331.31	905.1	8,117.97
2	Sidewalk, Rem	62	Sft	\$ 1.64	\$101.68	1868.60	\$3,064.50	1,806.6	2,962.82
3	Gate Valve & Well, Rem	10	Ea	\$ 335.87	\$3,358.70	12.00	\$4,028.04	2.0	671.34
4	Hydrant, Rem	3	Ea	\$ 456.60	\$1,370.40	4.00	\$1,827.20	1.0	456.80
5	Water Main, Rem	198	Lft	\$ 30.20	\$5,979.60	272.00	\$8,214.40	74.0	2,234.80
6	Water Main, 12 inch, Abandon in Place	1570	Lft	\$ 8.98	\$10,958.60	1570.00	\$10,958.60	0.0	0.00
7	Water Main, 6 inch, Abandon in Place	1892	Lft	\$ 4.95	\$9,365.40	1892.00	\$9,365.40	0.0	0.00
8	Dr Structure, Rem	1	Ea	\$ 336.11	\$336.11	1.00	\$336.11	0.0	0.00
9	Sewer, Rem, Less than 24 inch	16	Lft	\$ 56.01	\$896.16	52.00	\$2,912.52	36.0	2,016.36
10	Structure Abandonment Special	1	Ea	\$ 1,158.85	\$1,158.85	1.00	\$1,158.85	0.0	0.00
11	Water Main, 6 inch, C909 PVCO	208	Lft	\$ 163.11	\$33,926.88	358.00	\$58,393.38	150.0	24,466.50
12	Water Main, 12 inch, C809 PVCO	1615	Lft	\$ 162.42	\$262,308.30	1817.80	\$295,247.08	202.8	32,938.78
13	Water Main, 12 inch, Lining, CIPP	643	Lft	\$ 252.88	\$162,473.24	489.00	\$123,560.52	(154.0)	(38,912.72)
14	Water Main, 12 inch, C-900/RJ, HDD	50	Lft	\$ 344.61	\$17,230.50	100.00	\$34,461.00	50.0	17,230.50
15	Gate Valve & Well, 6 inch	4	Ea	\$ 6,110.79	\$24,443.16	4.00	\$24,443.16	0.0	0.00
16	Gate Valve & Well, 12 inch	5	Ea	\$ 8,872.84	\$44,364.20	4.00	\$35,491.36	(1.0)	(8,872.84)
17	Hydrant Assembly	6	Ea	\$ 6,889.34	\$41,336.04	6.00	\$41,336.04	0.0	0.00
18	Water Main Connection, 8 inch	10	Ea	\$ 6,840.19	\$68,401.90	8.00	\$41,041.14	(4.0)	(27,360.76)
19	Water Main Connection, 12 inch	3	Ea	\$ 8,943.52	\$26,830.56	8.00	\$71,548.16	5.0	44,717.60
20	Water Main Line Stop, 12" Dia (As Needed)	1	Ea	\$ 10,866.62	\$10,866.62	0.00	\$0.00	(1.0)	(10,866.62)
21	Catch Basin, Type "A"	1	Ea	\$ 4,286.64	\$4,286.64	1.00	\$4,286.64	0.0	0.00
22	Sewer, 12 inch, C76, CI IV w/Sand Backfill	16	Lft	\$ 183.63	\$2,142.28	54.00	\$7,228.82	38.0	5,086.54
23	Structure Adjust	11	Ea	\$ 429.44	\$4,723.84	19.00	\$8,159.36	8.0	3,435.52
24	Structure Reconstruct (up to 60" dia)	1	Ea	\$ 1,060.05	\$1,060.05	8.00	\$6,360.30	5.0	5,300.25
25	Sanitary Lead Repair, 6" (as needed)	20	Lft	\$ 132.16	\$2,643.20	42.00	\$5,550.72	22.0	2,907.52
26	TERS No.1	1	Lsum	\$ 15,000.00	\$15,000.00	0.00	\$0.00	(1.0)	(15,000.00)
27	TERS No.2	1	Lsum	\$ 15,000.00	\$16,000.00	0.70	\$10,500.00	(0.3)	(4,500.00)
28	TERS No.3 (Contractor Design)	1	Lsum	\$ 10,500.00	\$10,500.00	1.00	\$10,500.00	0.0	0.00
29	TERS No.4 (Contractor Design)	1	Lsum	\$ 10,500.00	\$10,500.00	1.00	\$10,500.00	0.0	0.00
30	TERS WALL A	1	Lsum	\$ 119,492.40	\$119,492.40	1.00	\$119,492.40	0.0	0.00
31	TERS WALL B	1	Lsum	\$ 68,292.28	\$68,292.28	1.00	\$68,292.28	0.0	0.00
32	Concrete Pavement, 6 inch w/Integral Curb, Nonreinf	1791	Syd	\$ 102.14	\$182,932.74	2453.19	\$250,568.83	662.2	67,636.09
33	Driveway, Concrete, 8 inch, Nonreinf	80	Syd	\$ 101.70	\$8,136.00	240.76	\$24,479.19	160.7	16,343.19
34	Concrete Sidewalk, 4 inch	48	Sft	\$ 12.15	\$583.20	308.60	\$3,725.19	258.8	3,141.99
35	Concrete ADA Ramp, 7 inch w/detectable warning	148	Sft	\$ 22.04	\$3,261.92	140.00	\$3,085.60	(8.0)	(176.32)
36	Aggregate Base, 10 inch, CIP, 21AA	2360	Syd	\$ 21.63	\$51,046.80	3573.97	\$77,304.87	1,214.0	26,258.17
37	HMA, 5E3	88	Ton	\$ 306.60	\$26,980.80	0.00	\$0.00	(88.0)	(26,980.80)
38	Subgrade Undercutting, 1x3	400	Cyd	\$ 50.80	\$20,320.00	97.40	\$4,928.44	(302.6)	(15,391.56)
39	Cold Weather Protection	1800	Syd	\$ 13.26	\$23,868.00	1044.44	\$13,849.27	(755.6)	(10,018.73)
40	Traffic Control and Maintenance (Materials, Equipment and Labor)	1	Lsum	\$ 11,600.62	\$11,600.62	1.00	\$11,600.62	0.0	0.00
41	Maintenance Gravel	450	Ton	\$ 35.81	\$16,114.50	933.13	\$33,449.13	483.1	16,334.63

42	Sign, Rem. Salv and Reinstall	2	Ea	\$ 276.21	\$552.42	0.00	\$0.00	(2.0)	(552.42)
43	Restoration, Hydroseeding (Incl. 3" Topsoil, Seed & Fertilizer)	2600	Syd	\$ 15.99	\$41,574.00	4072.10	\$65,112.58	1,472.1	23,638.08
44	Aggregate Surface Cse, 21A, 6 Inch	270	Syd	\$ 9.25	\$2,497.50	205.02	\$1,898.44	(65.0)	(601.07)
45	BONDS, INSURANCE AND INITIAL SET-UP EXPENSE (Not to exceed 5% of construction cost)	1	Lsum	\$ 33,144.62	\$33,144.62	1.00	\$33,144.62	0.0	0.00
46	Repair Mis-Marked or Unmarked Water Service	2	Ea	\$ 1,340.83	\$2,681.66	1.00	\$1,340.83	(1.0)	(1,340.83)
47	Downtime Due to Mis-Marked Water Service	8	Hr	\$ 498.31	\$3,986.48	17.50	\$8,720.43	9.5	4,733.95
48	Prefabricated Portable Sanitary Facility	1	Ea	\$ 662.89	\$662.89	1.00	\$662.89	0.0	0.00
49	Exploratory Excavation and Utility Locating	1	Lsum	\$ 3,322.05	\$3,322.05	1.00	\$3,322.05	0.0	0.00
50	Audio-Visual Filming	1	Lsum	\$ 1,657.23	\$1,657.23	1.00	\$1,657.23	0.0	0.00
51	Erosion Control Measures	1	Lsum	\$ 2,278.90	\$2,278.90	1.00	\$2,278.90	0.0	0.00
52	Permit Fee Allowance	5000	Dir	\$ 1.00	\$5,000.00	0.00	\$0.00	(5,000.0)	(5,000.00)
53	Fence, Protective	200	Fl	\$ 38.57	\$7,734.00	256.00	\$9,889.52	56.0	2,165.52
54	Fence, Protective, Temp Base	20	Ea	\$ 175.67	\$3,513.40	20.00	\$3,513.40	0.0	0.00
55	Railroad Inspection and Flagging	20000	Dir	\$ 1.00	\$20,000.00	0.00	\$0.00	(20,000.0)	(20,000.00)
56	Railroad Protection, at Grade Crossing	5000	Dir	\$ 1.00	\$5,000.00	0.00	\$0.00	(5,000.0)	(5,000.00)
57	Contingency For Work Outside of The Original Pay Items	20000	Dir	\$ 1.00	\$20,000.00	6905.01	\$6,905.01	(13,095.0)	(13,084.99)
	\$3,405.1 for gas line; \$3,600 for sink hole								
CONTINGENCY ITEMS									
58	6" D.I. Hydrant Lead		Fl	\$ 131.85		72.00	\$9,493.20	72.00	9,493.20
59	6" Edge Drain		Fl	\$ 21.80		1061.00	\$23,565.80	1061.00	23,565.80
60	1" Water Service		Ea		1689.25	2.00	\$3,778.50	2.00	3,778.50
61	1.5" Water Service		Ea	\$ 2,718.62		1.00	\$2,718.62	1.00	2,718.62
62	Tree Removal, 8"-18"		Ea	\$ 2,438.96		2.00	\$4,877.92	2.00	4,877.92
63	Pavement, Rem 2'-3'		Syd	\$ 8.94		322.20	\$2,880.47	322.20	2,880.47
64	Frame & Cover		Ea	\$ 851.35		9.00	\$7,662.15	9.00	7,662.15
65	12" Valve & Box		Ea	\$ 6,680.04		1.00	\$6,680.04	1.00	6,680.04
66	Remove & Replace 12" Gate Valve & Well @ Gratiot		Ea	\$ 22,784.27		1.00	\$22,784.27	1.00	22,784.27
67	2" Water Service		Ea	\$ 3,618.62		1.00	\$3,618.62	1.00	3,618.62
68	Exploratory digging on Groesback		Ea	\$ 11,641.65		1.00	\$11,641.65	1.00	11,641.65
69	6" Sidewalk		Sfl	\$ 17.74		1445.10	\$25,636.07	1445.10	25,636.07
70	Concrete Pavement, 9 inch w/integral Curb, Nonreinf		Syd	\$ 115.72		500.00	\$57,860.00	500.00	57,860.00
71	Variable Curb		Fl	\$ 55.00		28.00	\$1,540.00	28.00	1,540.00
72	Credit for grout to abandon 12" Water Main		Fl	\$ (2.25)		1570.00	-\$3,532.50	1570.00	(3,532.50)
73	Credit for grout to abandon 8" Water Main		Fl	\$ (1.50)		1892.00	-\$2,838.00	1892.00	(2,838.00)
Original Contract Amount					\$1,497,035.56		\$1,784,497.51		\$287,461.95
Contract Modification No. 1					184,637.93				
Contract Modification No. 2 and Final					111,842.38				
Final Contract Amount					\$1,793,515.87				
Percent Change from the Amended Contract Amount					19.20%				

**RESOLUTION APPROVING CONTRACT MODIFICATION NO. 2 AND FINAL
AND PAYMENT NUMBER 7 AND FINAL
FOR
TO CITY CONTRACT W-22-738
TOEPFER ROAD WATER MAIN REPLACEMENT
(HOOVER RD TO GROESBECK HWY.)
(AIELLI CONSTRUCTION COMPANY)**

At a regular meeting of the City Council of the City of Warren, County of Macomb, Michigan, held on _____, 2024, at 7:00 p.m. Eastern _____ Time, in the Council Chamber at the Warren Community Center Auditorium, 5460 Arden, Warren, Michigan.

PRESENT: Councilmembers _____

ABSENT: Councilmembers _____

The following preamble and resolution were offered by Councilmember _____, and supported by Councilmember _____.

Aielli Construction Company and the City of Warren entered into a contract titled W-22-738 Toepfer Road Water Main Replacement.

Certain changes to the plans and specifications were deemed necessary by the City Engineer due to additional work outside the scope of original contract, field changes, modifications to the original pay items to as-constructed quantities.

In compliance with Section 200, Subsections 236, 238 and 239, Aielli Construction Company and the City Engineer have determined mutually acceptable prices for the additional work and for the modifications to the original contract work.

The Engineering Division recommends approval of the attached Contract Modification No. 2 and Final to the City Contract W-22-738 Toepfer Road Water Main Replacement with the Aielli

Construction Company as submitted, increasing the current contract amount by \$102,824.02 resulting in a final contract amount of \$1,784,497.51.

The City Engineer also recommends that Payment No. 7 and Final to Aielli Construction Company in the amount of \$177,675.80 be issued three (3) days after the approval of Contract Modification No. 2 and Final.

The Engineering Division further recommends Payment No. 7 and Final in the amount of \$177,675.80 for the work completed under the contract WP-22-738, Toepfer Road Water Main Replacement with Aielli Construction Company after three (3) days of the City Council approval of the attached Contract Modification No. 2 and Final.

NOW, THEREFORE, IT IS RESOLVED, that the City of Warren does approve a modification to the Contract titled W-22-738, Toepfer Road Water Main, awarded to Aielli Construction Company, increasing the amended contract amount by \$102,824.02, as presented in the attached Contract Modification No. 2 and Final.

IT IS FURTHER RESOLVED, that the Mayor and Clerk of the City of Warren are hereby authorized to execute Contract Modification No. 2 and Final to City Project WP-22-738, Toepfer Road Water Main Replacement in such form that meets with the approval of the City Attorney.

IT IS FURTHER RESOLVED, that Payment No. 7 and Final in the amount of \$177,675.80 payable to Aielli Construction Company be issued after three (3) days of the City Council's approval of the Contract Modification No. 2 and Final including releasing any interest on retainage

AYES: Councilpersons _____

NAYES: Councilpersons _____

RESOLUTION DECLARED ADOPTED this _____ day of _____ 2024.

MINDY MOORE
Secretary of the Council

CERTIFICATION

STATE OF MICHIGAN)
) SS.
COUNTY OF MACOMB)

I, SONJA BUFFA, duly elected City Clerk for the City of Warren, Macomb County, Michigan, certify that the foregoing is a true and correct copy of the resolution adopted by the Council of the City of Warren at its meeting held on _____, 2024.

SONJA BUFFA
City Clerk

W-22-738 Toepfer Road Water Main Replacement
Contract Modification 2 & Final
Aielli Construction Company



PAYMENT REQUEST

Date : May 6, 2024

NOTE: CITY COUNCIL APPROVAL REQ

To : Sara Karpuk, Budget Cost Analyst, Controller's Office

From : Engineering Division

Re :	Payment No.	7 and Final	Payee :	Aielli Construction Company, Inc
	Project No.	W-22-738		47742 Van Dyke
	Location	Toepfer Road Hoover to Groesbeck		Shelby Township, MI 48317
	Improvement:	Water Main Replacement		

Original Contract Amount (City Council Approval 6/13/23)	<u>\$1,497,035.56</u>
Contract Modification No. 1 (City Council Approval 4/9/2024)	<u>\$184,637.93</u>
Prop. Contract Modification No. 2 and Final	<u>\$102,824.02</u>
Final Contract Amount	<u>\$1,784,497.51</u>

Total Work performed as of: 4/27/24	<u>\$1,784,497.51</u>
Less Retainage 0.00%	<u>\$0.00</u>
Net Amount Earned	<u>\$1,784,497.51</u>
Amount of Previous Payment Requests	<u>\$1,606,821.71</u>

Amount Due This Estimate **\$177,675.80**

Retainage Previously Withheld	<u>\$74,851.78</u>
Retainage Change this Pay Estimate	<u>-\$74,851.78</u>

Chargeable to :	2023 Water & Sewer Capital Improvement Fund	\$177,675.80
-----------------	--	---------------------

Prepared by:

Approved for Payment:



 Olivia C. Girimonte
 Civil Engineer

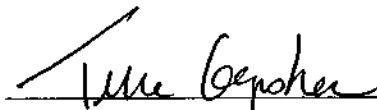

 Tina Gapshes, P.E.
 City Engineer

cc: Payee

CONTRACTOR: Aielli Construction Company
 ADDRESS: 47742 Van Dyke Ave Shelby Township, MI 48317

DATE: 4/27/2024
 HRC Job #: 20210026

City of Warren
 Toepfer Road Water Main Replacement (Hoover Rd. to Groesbeck Hwy.)
 City Contract W-22-738
 Pay Estimate No. 7 (FINAL)

Item No.	Item	Original Contract Quantity	Unit	Contract Bid Price	Original Bid Amount	Auth. Qty to Date	Payment
1	Pavement, Rem	2261	Syd	\$ 8.94	\$ 20,213.34	3169.05	\$ 28,331.31
2	Sidewalk, Rem	62	Sft	\$ 1.64	\$ 101.66	1868.60	\$ 3,064.50
3	Gate Valve & Well, Rem	10	Ea	\$ 335.67	\$ 3,356.70	12.00	\$ 4,028.04
4	Hydrant, Rem	3	Ea	\$ 456.80	\$ 1,370.40	4.00	\$ 1,827.20
5	Water Main, Rem	198	Lft	\$ 30.20	\$ 5,979.60	272.00	\$ 8,214.40
6	Water Main, 12 inch, Abandon in Place	1570	Lft	\$ 6.98	\$ 10,958.60	1570.00	\$ 10,958.60
7	Water Main, 8 inch, Abandon in Place	1892	Lft	\$ 4.95	\$ 9,365.40	1892.00	\$ 9,365.40
8	Dr Structure, Rem	1	Ea	\$ 336.11	\$ 336.11	1.00	\$ 336.11
9	Sewer, Rem, Less than 24 inch	16	Lft	\$ 56.01	\$ 896.16	52.00	\$ 2,912.52
10	Structure Abandonment Special	1	Ea	\$ 1,158.85	\$ 1,158.85	1.00	\$ 1,158.85
11	Water Main, 8 Inch, C909 PVC	208	Lft	\$ 163.11	\$ 33,926.88	358.00	\$ 58,393.38
12	Water Main, 12 inch, C909 PVC	1615	Lft	\$ 162.42	\$ 262,306.30	1817.80	\$ 295,247.08
13	Water Main, 12 inch, Lining, CIPP	643	Lft	\$ 252.68	\$ 162,473.24	489.00	\$ 123,560.52
14	Water Main, 12 inch, C-930/RJ, HDD	50	Lft	\$ 344.61	\$ 17,230.50	100.00	\$ 34,461.00
15	Gate Valve & Well, 8 inch	4	Ea	\$ 6,110.79	\$ 24,443.16	4.00	\$ 24,443.16
16	Gate Valve & Well, 12 inch	5	Ea	\$ 8,872.84	\$ 44,364.20	4.00	\$ 35,491.36
17	Hydrant Assembly	6	Ea	\$ 6,889.34	\$ 41,336.04	6.00	\$ 41,336.04
18	Water Main Connection, 8 inch	10	Ea	\$ 6,840.19	\$ 68,401.90	6.00	\$ 41,041.14
19	Water Main Connection, 12 inch	3	Ea	\$ 8,943.52	\$ 26,830.56	8.00	\$ 71,548.16
20	Water Main Line Stop, 12" Dia (As Needed)	1	Ea	\$ 10,866.62	\$ 10,866.62	0.00	\$ -
21	Catch Basin, Type "A"	1	Ea	\$ 4,286.64	\$ 4,286.64	1.00	\$ 4,286.64
22	Sewer, 12 inch, C76, CI IV w/Sand Backfill	16	Lft	\$ 133.83	\$ 2,141.28	54.00	\$ 7,226.82
23	Structure Adjust	11	Ea	\$ 429.44	\$ 4,723.84	19.00	\$ 8,159.36
24	Structure Reconstruct (up to 60" dia)	1	Ea	\$ 1,060.05	\$ 1,060.05	6.00	\$ 6,360.30
25	Sanitary Lead Repair, 6" (as needed)	20	Lft	\$ 132.16	\$ 2,643.20	42.00	\$ 5,550.72
26	TERS No.1	1	Lsum	\$ 15,000.00	\$ 15,000.00	0.00	\$ -
27	TERS No.2	1	Lsum	\$ 15,000.00	\$ 15,000.00	0.70	\$ 10,500.00
28	TERS No.3 (Contractor Design)	1	Lsum	\$ 10,500.00	\$ 10,500.00	1.00	\$ 10,500.00
29	TERS No.4 (Contractor Design)	1	Lsum	\$ 10,500.00	\$ 10,500.00	1.00	\$ 10,500.00
30	TERS WALL A	1	Lsum	\$ 119,492.40	\$ 119,492.40	1.00	\$ 119,492.40
31	TERS WALL B	1	Lsum	\$ 68,292.26	\$ 68,292.26	1.00	\$ 68,292.26
32	Concrete Pavement, 8 inch w/Integral Curb, Nonreinf	1791	Syd	\$ 102.14	\$ 182,932.74	2453.19	\$ 250,568.83
33	Driveway, Concrete, 8 inch, Nonreinf	80	Syd	\$ 101.70	\$ 8,136.00	240.70	\$ 24,479.19
34	Concrete Sidewalk, 4 inch	48	Sft	\$ 12.15	\$ 583.20	306.60	\$ 3,725.19
35	Concrete ADA Ramp, 7 inch w/detectable warning	148	Sft	\$ 22.04	\$ 3,261.92	140.00	\$ 3,085.60
36	Aggregate Base, 10 inch, CIP, 21AA	2360	Syd	\$ 21.63	\$ 51,046.80	3573.97	\$ 77,304.97
37	HMA, 5E3	88	Ton	\$ 306.69	\$ 26,988.72	0.00	\$ -
38	Subgrade Undercutting, 1x3	400	Cyd	\$ 50.80	\$ 20,240.00	97.40	\$ 4,928.44
39	Cold Weather Protection	1800	Syd	\$ 13.26	\$ 23,868.00	1044.44	\$ 13,849.27
40	Traffic Control and Maintenance (Materials, Equipment and Labor)	1	Lsum	\$ 11,600.62	\$ 11,600.62	1.00	\$ 11,600.62
41	Maintenance Gravel	450	Ton	\$ 33.81	\$ 15,214.50	933.13	\$ 31,549.13
42	Sign, Rem, Salv and Reinstall	2	Ea	\$ 276.21	\$ 552.42	0.00	\$ -
43	Restoration, Hydroseeding (Incl. 3" Topsoil, Seed & Fertilizer)	2600	Syd	\$ 15.99	\$ 41,574.00	4,072.10	\$ 65,112.88
44	Aggregate Surface Cse, 21A, 6 inch	270	Syd	\$ 9.25	\$ 2,497.50	205.02	\$ 1,896.44

City of Warren
 Toepfer Road Water Main Replacement (Hoover Rd. to Groesbeck Hwy.)
 City Contract W-22-738

Pay Estimate No. 7 (FINAL)

45	BONDS, INSURANCE AND INITIAL SET-UP EXPENSE (Not to exceed 5% of construction cost)	1	Lsum	\$ 33,144.62	\$ 33,144.62	1.00	\$ 33,144.62
46	Repair Mis-Marked or Unmarked Water Service	2	Ea	\$ 1,340.83	\$ 2,681.66	1.00	\$ 1,340.83
47	Downtime Due to Mis-Marked Water Service	8	Hr	\$ 498.31	\$ 3,986.48	17.50	\$ 8,720.43
48	Prefabricated Portable Sanitary Facility	1	Ea	\$ 662.89	\$ 662.89	1.00	\$ 662.89
49	Exploratory Excavation and Utility Locating	1	Lsum	\$ 3,322.05	\$ 3,322.05	1.00	\$ 3,322.05
50	Audio-Visual Filming	1	Lsum	\$ 1,657.23	\$ 1,657.23	1.00	\$ 1,657.23
51	Erosion Control Measures	1	Lsum	\$ 2,278.90	\$ 2,278.90	1.00	\$ 2,278.90
52	Permit Fee Allowance	5000	Dir	\$ 1.00	\$ 5,000.00	0.00	\$ -
53	Fence, Protective	200	Ft	\$ 38.67	\$ 7,734.00	256.00	\$ 9,899.52
54	Fence, Protective, Temp Base	20	Ea	\$ 175.67	\$ 3,513.40	20.00	\$ 3,513.40
55	Railroad Inspection and Flagging	20000	Dir	\$ 1.00	\$ 20,000.00	0.00	\$ -
56	Railroad Protection, at Grade Crossing	5000	Dir	\$ 1.00	\$ 5,000.00	0.00	\$ -
57	Contingency For Work Outside of The Original Pay Items	20000	Dir	\$ 1.00	\$ 20,000.00	6905.01	\$ 6,905.01
	\$3,405.1 for gas line; \$3,500 for sink hole						
	Contingency Items						
58	6" D.I. Hydrant Lead		Ft	\$ 131.85	\$ -	72.00	\$ 9,493.20
59	6" Edge Drain		Ft	\$ 21.80	\$ -	1081.00	\$ 23,565.80
60	1" Water Service		Ea	\$ 1,889.25	\$ -	2.00	\$ 3,778.50
61	1.5" Water Service		Ea	\$ 2,718.62	\$ -	1.00	\$ 2,718.62
62	Tree Removal, 8"-18"		Ea	\$ 2,436.96	\$ -	2.00	\$ 4,877.92
63	Pavement, Rem 2'-3'		Syd	\$ 8.94	\$ -	322.20	\$ 2,880.47
64	Frame & Cover		Ea	\$ 851.35	\$ -	9.00	\$ 7,662.15
65	12" Valve & Box		Ea	\$ 6,680.04	\$ -	1.00	\$ 6,680.04
66	Remove & Replace 12" Gate Valve & Well @ Gratiot		Ea	\$ 22,784.27	\$ -	1.00	\$ 22,784.27
67	2" Water Service		Ea	\$ 3,616.62	\$ -	1.00	\$ 3,616.62
68	Exploratory digging on Groesbeck		Ea	\$ 11,641.65	\$ -	1.00	\$ 11,641.65
69	6" Sidewalk		Sft	\$ 17.74	\$ -	1445.10	\$ 25,636.07
70	Concrete Pavement, 9 inch w/Integral Curb, Nonreinf		Syd	\$ 115.72	\$ -	500.00	\$ 57,860.00
71	Variable Curb		Ft	\$ 55.00	\$ -	28.00	\$ 1,540.00
72	Credit for grout to abandon 12" Water Main		Ft	\$ (2.25)	\$ -	1570.00	\$ (3,532.50)
73	Credit for grout to abandon 8" Water Main		Ft	\$ (1.50)	\$ -	1892.00	\$ (2,838.00)
				Total Amount of Contract	\$ 1,497,035.56		
				Total Amount to Date			\$ 1,784,497.51
				Less Retainage			\$ -
				Less Amount- Pay Estimate No. 1			\$ 203,002.70
				Less Amount- Pay Estimate No. 2			\$ 290,709.07
				Less Amount - Pay Estimate No. 3			\$ 327,913.33
				Less Amount - Pay Estimate No. 4			\$ 140,199.16
				Less Amount - Pay Estimate No. 5			\$ 348,458.51
				Less Amount - Pay Estimate No. 6			\$ 296,538.94
				Total Amount Due - Pay Estimate No. 7 FINAL			\$ 177,675.80

I certify that I have checked this periodic estimate; that to the best of my knowledge and belief it is a true and correct statement of work performed by the contractor; that all work included in this periodic estimate has been inspected and it has been performed in full accordance with the requirements of the contract.

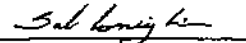
 HUBBELL, ROTH & CLARK, INC.
 Sal Conigliaro, P.E.

City Project No. W-22-738, Toepfer Road
 Water Main Replacement
 Pay Estimate No. 7 and Final



Contractor:
 Address:
 City:

Aielll Construction Company, Inc.
 47742 Van Dyke
 Shelby Township, MI 48317

DESCRIPTION	ORIGINAL CONTRACT AMOUNT	FINAL CONTRACT AMOUNT	AMOUNT PAID TO DATE	AMOUNT THIS PAYMENT
Total Work Performed as of:				
Less Retainage	4/27/24	\$ 1,497,035.56	\$ 1,784,497.51	\$ 1,784,497.51
Net Amount Earned	0.00%		\$ -	\$ -
Less Previous Payments			\$ 1,784,497.51	\$ 1,784,497.51
Total Amount Due this Estimate			\$ 1,606,821.71	\$ 1,606,821.71
			\$ 177,675.80	\$ 177,675.80
Total 2023 Water & Sewer Improvement Fund Work Performed as of:	4/27/24	\$ 1,497,035.56		
Less Retainage	0.00%		\$ 1,784,497.51	\$ 1,784,497.51
Net Amount Earned			\$ -	\$ -
Less Previous Payments			\$ 1,784,497.51	\$ 1,784,497.51
Total 2023 Water & Sewer Capital Improvement Fund Due this Estimate			\$ 1,606,821.71	\$ 1,606,821.71
			\$ 177,675.80	\$ 177,675.80

I certify that I have checked this periodic estimate, that to the best of my knowledge and belief it is true and correct statement of work performed by the contractor, that all work included in this periodic estimate has been inspected by me or my duly authorized representative or assistants and it has been performed in full accordance with the requirements of the contract.

Tina Green
 for the City of Warren, Tina Green, P.E.
 City Engineer

for Aielll Construction Company, Inc.

According to the best of my knowledge and belief I certify that all items and amounts shown on this periodic estimate are correct, that all work has been performed in full accordance with the requirements of the Contract, that the foregoing is a true and correct statement of the contract account up to and including the last day of the period covered by the periodic estimate, that no part of the balance due this estimate has been received. That payment of same due herewith, is without collusion and fraud in any respect.



**PUBLIC SERVICE DEPARTMENT
ENGINEERING DIVISION**

One City Square, Suite 300
Warren, Michigan 48093-2390

P: (586) 759-9300

F: (586) 759-9318

www.cityofwarren.org

May 9, 2024

Ms. Mindy Moore
City Council Secretary

RE: CONSIDERATION AND ADOPTION OF RESOLUTION to Award Bid and Contract for City Project P-24-811, Miller & Denton – Pavement Reconstruction, (ITB-W-0959) to the low bidder, Zuniga Cement Construction, Inc., in the total bid amount not to exceed \$1,469,722.75.

Electronics bids were received and publicly read via Zoom Video Conferencing on May 8, 2024 for City Project P-24-811, Miller & Denton – Pavement Reconstruction, (ITB-W-0959). This project was publicly advertised on the BidNet (MITN) system on April 24, 2024. The scope of the project includes the reconstruction of concrete pavement along Miller Drive and Denton Drive from Van Dyke Ave to Chicago Road. This includes replacing drive approaches, sidewalks, A.D.A. ramps, edge drain installation, and minor catch basin repairs, and related restoration as necessary.

The Engineering Division recommends that the Warren City Council award the Contract P-24-811, Miller & Denton – Pavement Reconstruction to the low bidder – Zuniga Cement Construction, Inc. in the total bid amount not to exceed \$1,469,722.75. Zuniga Cement Construction, Inc. has successfully completed similar work in the City of Warren and in the surrounding Metro area.

The form of the contract document and the proposed City Council resolution authorizing approval of the contract award has been sent for review to the City Attorney. The availability of the funding for this contract, as stated in the attached City Council resolution, has been confirmed and approved by the Budget Director.

Please place this item on the next available City Council agenda for consideration. If you have any questions regarding this matter, I can be reached in my office at (586) 759-9306.

Sincerely,

Read and Concurred:

Funding Approval:



Tina G. Gapshes, P.E.
City Engineer



David Muzzarelli
Public Service Director

Kristina Battle
Budget Director

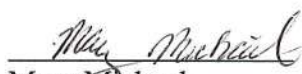
Contract Form Approval:

Recommended to Council:

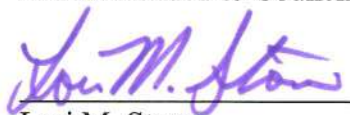
Mary Michaels
Acting City Attorney

Lori M. Stone
Mayor

TGG/DRW

Attachments: Tabulation of Bids and Recommendation, City Council Resolution



BID TABULATION

City Project P-24-811 (ITB-W-0959)
Miller & Denton – Pavement Reconstruction

Uniga Cement Const. 22500 Ryan Warren, MI 48091	Florence Cement 51515 Corridor Shelby Twp, MI 48315	Mark Anthony Contract. 4810 Old Plank Milford, MI 48381
---	---	---

ITEM No.	PAY ITEM DESCRIPTION	UNITS	QUANTITY	UNIT PRICE	AMOUNT	UNIT PRICE	AMOUNT	UNIT PRICE	AMOUNT
DEMOLITION ITEMS									
1	REMOVE SIDEWALK, A.D.A. RAMP OR DRIVE APPROACH	SF	7,645	\$ 2.00	\$ 15,290.00	\$ 1.90	\$ 14,525.50	\$ 1.30	\$ 9,938.50
2	REMOVE EXISTING PAVEMENT INCLUDING INTEGRAL CURB AND GUTTER (SEE GEOTECHNICAL REPORT)	SY	10,791	\$ 9.00	\$ 97,119.00	\$ 7.90	\$ 85,248.90	\$ 8.32	\$ 89,781.12
PAVING ITEMS									
3	INSTALL 10" THICK CONCRETE PAVEMENT WITH INTEGRAL CURB AND GUTTER, USING SLIP FORM PAVEMENT, M.D.O.T. P1 (6 SACK CEMENT CONTENT)	SY	10,791	\$ 68.00	\$ 733,788.00	\$ 74.70	\$ 806,087.70	\$ 77.19	\$ 832,957.29
4	INSTALL 8" THICK CONCRETE SIDEWALK, A.D.A. RAMP OR DRIVE APPROACH, M.D.O.T. GRADE P-NC (7 SACK CEMENT CONTENT)	SF	6,481	\$ 9.75	\$ 63,189.75	\$ 10.70	\$ 69,346.70	\$ 9.77	\$ 63,319.37
5	INSTALL 4" THICK CONCRETE SIDEWALK, M.D.O.T. GRADE P1 (6 SACK CEMENT CONTENT)	SF	628	\$ 8.00	\$ 5,024.00	\$ 8.85	\$ 5,557.80	\$ 6.68	\$ 4,195.04
6	INSTALL 6" THICK CONCRETE SIDEWALK, A.D.A. RAMP OR DRIVE APPROACH, M.D.O.T. GRADE P-NC (7 SACK CEMENT CONTENT)	SF	1,041	\$ 9.00	\$ 9,369.00	\$ 9.35	\$ 9,733.35	\$ 8.81	\$ 9,171.21
7	INSTALL M.D.O.T. CLASS 21AA LIMESTONE SUB-BASE, (MIN. 10" THICK C.I.P.) UNDER CONCRETE PAVEMENT	SY	11,342	\$ 12.00	\$ 136,104.00	\$ 18.90	\$ 214,363.80	\$ 18.68	\$ 211,868.56
8	SUBGRADE UNDERCUT - EXCAVATE UNSUITABLE SUBGRADE MATERIAL AND BACKFILL INSTALL 1x3, TYPE IV - CRUSHED LIMESTONE (C.I.P.) FOR FILLING UNDERCUT	CY	298	\$ 20.00	\$ 5,960.00	\$ 88.00	\$ 26,224.00	\$ 86.61	\$ 25,809.78
9	INSTALL TENSAR BX1100 OR EQUIVALENT GEOGRID TO STABILIZE THE UNDERCUT AREA(S)	SY	900	\$ 1.00	\$ 900.00	\$ 2.15	\$ 1,935.00	\$ 3.00	\$ 2,700.00
10	STATION GRADING	STA	24	\$ 5,500.00	\$ 133,650.00	\$ 7,130.00	\$ 173,259.00	\$ 7,500.71	\$ 182,267.25
11	INSTALL A.D.A. COMPLIANT DETECTABLE WARNING DEVICE	LF	20	\$ 50.00	\$ 1,000.00	\$ 75.00	\$ 1,500.00	\$ 42.92	\$ 858.40
12	VARIABLE HEIGHT SIDEWALK CURB (AS-NEEDED)	LF	100	\$ 10.00	\$ 1,000.00	\$ 50.00	\$ 5,000.00	\$ 21.47	\$ 2,147.00
13	PAVEMENT MARKING, SPRAYABLE THERMOPLASTIC, 4" YELLOW	FT	5,160	\$ 0.75	\$ 3,870.00	\$ 0.75	\$ 3,870.00	\$ 0.89	\$ 4,592.40
14	PAVEMENT MARKING (1 STOP BAR), OVERLAY COLD PLASTIC, 18" STOP BAR	FT	16	\$ 15.00	\$ 240.00	\$ 15.00	\$ 240.00	\$ 17.89	\$ 286.24
15	PAVEMENT MARKING (3 CROSSWALKS), OVERLAY COLD PLASTIC, 6" CROSSWALK	FT	216	\$ 5.00	\$ 1,080.00	\$ 5.00	\$ 1,080.00	\$ 5.96	\$ 1,287.36
16	PAVEMENT MARKING (3 CROSSWALKS), OVERLAY COLD PLASTIC, 12" CROSS HATCHING, WHITE	FT	36	\$ 10.00	\$ 360.00	\$ 10.00	\$ 360.00	\$ 11.93	\$ 429.48
17	COLD WEATHER PROTECTION (AS-NEEDED)	SY	5,396	\$ 5.00	\$ 26,980.00	\$ 0.01	\$ 53.96	\$ 0.01	\$ 53.96
UTILITY ITEMS									
17	REBUILD 2' DIA. MANHOLE, CATCH BASIN, INLET OR GATE WELL, COMPLETE (INCLUDING EXTERNAL STRUCTURE WRAP)	VF	1	\$ 350.00	\$ 350.00	\$ 750.00	\$ 750.00	\$ 1,033.87	\$ 1,033.87
18	REBUILD 4' DIA. MANHOLE, CATCH BASIN, INLET OR GATE WELL, COMPLETE (INCLUDING EXTERNAL STRUCTURE WRAP)	VF	8	\$ 400.00	\$ 3,200.00	\$ 410.00	\$ 3,280.00	\$ 1,276.63	\$ 10,213.04
19	ADJUST 2' DIA. UTILITY STRUCTURE, COMPLETE (INCLUDING HDPE/CONCRETE OR EQUIVALENT ADJUSTMENT RING)	EA	5	\$ 500.00	\$ 2,500.00	\$ 600.00	\$ 3,000.00	\$ 328.54	\$ 1,642.70
20	ADJUST 4' DIA. UTILITY STRUCTURE, COMPLETE (INCLUDING HDPE/CONCRETE OR EQUIVALENT ADJUSTMENT RING)	EA	10	\$ 500.00	\$ 5,000.00	\$ 700.00	\$ 7,000.00	\$ 1,200.86	\$ 12,008.60
21	INSTALL 6" DIA. CORRUGATED PLASTIC EDGE DRAIN WITH GEOTEXTILE WRAP, COMPLETE	LF	4,974	\$ 14.00	\$ 69,636.00	\$ 11.95	\$ 59,439.30	\$ 15.79	\$ 78,539.46
22	INSTALL A.D.A. COMPLIANT OR STANDARD FRAME FOR MANHOLE, CATCH BASIN, INLET OR GATE WELL	EA	15	\$ 550.00	\$ 8,250.00	\$ 335.00	\$ 5,025.00	\$ 389.66	\$ 5,844.90
23	INSTALL A.D.A. COMPLIANT OR STANDARD COVER FOR MANHOLE, CATCH BASIN, INLET OR GATE WELL	EA	15	\$ 350.00	\$ 5,250.00	\$ 335.00	\$ 5,025.00	\$ 278.16	\$ 4,172.40
24	MAINTENANCE GRAVEL, INSTALL AND MAINTAIN (COMPLETE)	TON	300	\$ 20.00	\$ 6,000.00	\$ 26.00	\$ 7,800.00	\$ 29.51	\$ 8,853.00
TRAFFIC CONTROL ITEMS									
25	TRAFFIC CONTROL DEVICES, COMPLETE	LS	1	\$ 6,950.00	\$ 6,950.00	\$ 10,000.00	\$ 10,000.00	\$ 23,272.68	\$ 23,272.68
26	TEMPORARY TRAFFIC CONTROL OR INFORMATIONAL SIGNS	SF	300	\$ 6.00	\$ 1,800.00	\$ 6.00	\$ 1,800.00	\$ 7.16	\$ 2,148.00
RESTORATION ITEMS									
27	INSTALL SEED AND MULCH	LS	1	\$ 25,000.00	\$ 25,000.00	\$ 20,000.00	\$ 20,000.00	\$ 28,179.90	\$ 28,179.90
28	INSTALL TREE (AS-NEEDED)	EA	8	\$ 450.00	\$ 3,600.00	\$ 1,000.00	\$ 8,000.00	\$ 685.86	\$ 5,486.88
29	SPRINKLER LINE (AS-NEEDED)	LF	300	\$ 3.00	\$ 900.00	\$ 10.00	\$ 3,000.00	\$ 8.29	\$ 2,487.00
30	SPRINKLER HEAD, REPLACE (AS-NEEDED)	EA	10	\$ 45.00	\$ 450.00	\$ 95.00	\$ 950.00	\$ 89.46	\$ 894.60
31	SPRINKLER HEAD, RELOCATE (AS-NEEDED)	EA	10	\$ 60.00	\$ 600.00	\$ 85.00	\$ 850.00	\$ 77.53	\$ 775.30
MISCELLANEOUS ITEMS									
32	PREFABRICATED PORTABLE SANITARY FACILITY	EA	1	\$ 1,200.00	\$ 1,200.00	\$ 600.00	\$ 600.00	\$ 894.60	\$ 894.60
33	PROJECT CLEANUP	LS	1	\$ 3,000.00	\$ 3,000.00	\$ 1,000.00	\$ 1,000.00	\$ 10,515.77	\$ 10,515.77
34	CREW DOWNTIME FOR LOCATING MIS-MARKED / UNMARKED SERVICES OR FOR OTHER UNFORESEEN FIELD CONDITIONS	HR	8	\$ 1.00	\$ 8.00	\$ 440.00	\$ 3,520.00	\$ 417.48	\$ 3,339.84
35	REPAIR MIS-MARKED OR UNMARKED WATER SERVICE	EA	5	\$ 1.00	\$ 5.00	\$ 430.00	\$ 2,150.00	\$ 1.19	\$ 5.95
36	CONTINGENCY FOR WORK OUTSIDE OF THE ORIGINAL PAY ITEMS	LS	1	\$ 40,000.00	\$ 40,000.00	\$ 40,000.00	\$ 40,000.00	\$ 40,000.00	\$ 40,000.00
37	AUDIO-VISUAL RECORDING OF THE CONSTRUCTION AREA	LS	1	\$ 1,100.00	\$ 1,100.00	\$ 940.00	\$ 940.00	\$ 1,121.23	\$ 1,121.23
38	SOIL EROSION AND SEDIMENTATION CONTROL MEASURES INCLUDING MCPWC SOIL EROSION PERMIT FEE ALLOWANCE	LS	1	\$ 2,000.00	\$ 2,000.00	\$ 1,000.00	\$ 1,000.00	\$ 1,080.82	\$ 1,080.82
39	PERMIT AND INSPECTION FEE ALLOWANCE - AS NEEDED REIMBURSEMENT (Macomb County, SESC, EGLE)	LS	1	\$ 3,000.00	\$ 3,000.00	\$ 3,000.00	\$ 3,000.00	\$ 3,000.00	\$ 3,000.00
40	BONDS, INSURANCE, MOBILIZATION AND INITIAL SET-UP EXPENSE (Not to exceed 7% of construction cost)	LS	1	\$ 45,000.00	\$ 45,000.00	\$ 97,000.00	\$ 97,000.00	\$ 34,852.52	\$ 34,852.52
TOTAL BID AMOUNT					\$ 1,469,722.75		\$ 1,703,515.01		\$ 1,722,026.02

ITEM No.	ALTERNATE - PAY ITEM DESCRIPTION	UNITS	QUANTITY	UNIT PRICE	AMOUNT	UNIT PRICE	AMOUNT	UNIT PRICE	AMOUNT
41	INSTALL M.D.O.T. CLASS 21AA CRUSHED CONCRETE SUB-BASE, (MIN. 10" THICK C.I.P.) UNDER CONCRETE PAVEMENT	SY	11,342	\$ 10.00	\$ 113,420.00	\$ 17.90	\$ 203,021.80	\$ 17.00	\$ 192,814.00
42	INSTALL CLASS "A" SOD	SY	150	\$ 10.00	\$ 1,500.00	\$ 20.00	\$ 3,000.00	\$ 35.00	\$ 5,250.00

**RESOLUTION TO AWARD BID AND APPROVE CONTRACT FOR
P-24-811, MILLER & DENTON – PAVEMENT RECONSTRUCTION (ITB-W-0959)**

At a regular meeting of the City Council of the City of Warren, County of Macomb, Michigan, held on _____, 2024 at _____ p.m. Eastern Daylight Savings Time, in the Council Chamber at the Warren Community Center Auditorium, 5460 Arden, Warren, Michigan.

PRESENT: Councilpersons _____

ABSENT: Councilpersons _____

The following preamble and resolution were offered by Councilperson

_____ and supported by Councilperson _____.

On May 8, 2024, bids were received for City Project P-24-811, Miller & Denton – Pavement Reconstruction (ITB-W-0959), pursuant to the updated online electronic bid submittal process via BidNet Direct (MITN).

The City Council has received and reviewed the bids as listed on the attached tabulation.

The City Engineer has recommended that the contract for City Project P-24-811, Miller & Denton – Pavement Reconstruction (ITB-W-0959) be awarded to the lowest bidder Zuniga Cement Construction, Inc. in the total bid amount not to exceed \$1,469,722.75.

Funding is available in the 2023 Michigan Transportation Construction Fund (438-9438-97450) (\$1,424,421.84) and the 2024 MTOF Major Roads, Routine Maintenance - Pavement Repairs line item (202-2463-80206) (\$45,300.91).

The Contract documents include the Project Drawings, the Supplemental Specifications, the Advertisement, the Proposal, the Appendix and the City of Warren form documents entitled Instructions to Bidders, Contract, Performance Bond, Payment Bond for Labor, Material and Equipment Rental, Maintenance and Guarantee Bond, Certificate of Worker's Compensation Insurance, General Conditions, and the Specifications for Water Main, Sanitary and Storm Sewers.

THEREFORE, IT IS RESOLVED, pursuant to the recommendation of the City Engineer, that the City Council by formal motion approves the award of contract City Project P-24-811, Miller & Denton – Pavement Reconstruction (ITB-W-0959) to the lowest bidder Zuniga Cement Construction, Inc. in the



Lori M. Stone, Mayor
One City Square, Suite 215
Warren, MI 48093

MEMORANDUM

DATE: May 10, 2024

TO: Mindy Moore, Council Secretary

RE: Appointees

City Council:

Please be advised that the following individual has been appointed to a position within the city:

Name	Title
David Koss	Water Superintendent
Kevin Kitka	Sanitation Superintendent
F. Scott Miller	City Assessor

Thank you for your attention in this matter.

Sincerely,

A handwritten signature in purple ink, appearing to read "Lori M. Stone". The signature is fluid and cursive, with a large, sweeping flourish at the end.

Lori M. Stone
Mayor

Cc: Clerk



HUMAN RESOURCES DEPARTMENT
 ONE CITY SQUARE, SUITE 410
 WARREN, MI 48093-6726
 (586) 574-4670
 www.cityofwarren.org

DATE: MAY 21, 2024
 TO: MELINDA MOORE, SECRETARY OF WARREN CITY COUNCIL
 FROM: JACQUELINE DAMRON, ACTING HUMAN RESOURCES DIRECTOR
 SUBJECT: RECOMMENDATION TO AWARD AN AGREEMENT FOR FURNISHING RECRUITMENT SERVICES FOR THE CITY OF WARREN; ITB-W-1195.

The Purchasing Division concurs with the Acting Human Resources Director and recommends that City Council award bid ITB-W-1195 To Furnish Recruitment Services for the City of Warren for a one-year period, with options to extend for four (4) additional one-year periods, to Amy Cell, LLC. Located at 215 W. Michigan Ave, Ypsilanti, MI 48197, in an annual amount not exceed \$75,000.00.

On Wednesday, April 24, 2024, at 1:00 pm local time, electronic bids were publicly opened for ITB-W-1195 To Furnish Recruitment Services for the City of Warren. Ten (10) firms submitted a bid, which are summarized on the attached bid tabulation sheets submitted for your review.

If approved, these services will be utilized to find qualified candidates for various department head positions within the City and will commence upon the official date of City Council approval.

Funds are available in account 101-1220-80100.

The attached draft contract has been approved as to form by Assistant City Attorney, Laura Sullivan.

 Laura Sullivan

Atty Name Here
 Assistant City Attorney

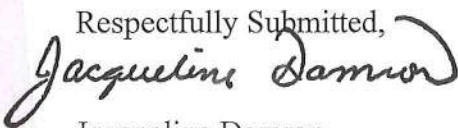
Respectfully Submitted,

Jacqueline Damron
 Acting Human Resources Director

Approved By:	Signature	Date
Purchasing Agent:		5-21-24
Budget Director:		5-21-2024
Controller:		5-21-24
MAYOR:		5/22/24

AS-READ BID SUMMARY

City of Warren One City Square Warren MI 48093		BID: ITB-W-1195 Bid Opening Date: 4/24/2024 Department: HUMAN RESOURCES
Product of Service: FURNISH RECRUITING SERVICES		
BIDDER	LEVEL 1 RECRUITMENT	LEVEL 2 RECRUITMENT
AMY CELL TALENT, LLC.	\$ 18,500.00	\$ 4,950.00
AQUIYEL BUSINESS SERVICES	18% MARK UP	18.5% MARK UP
BLUE CHIP TALENT	\$ 30,000.00	\$ 25,000.00
DSI MEDICAL SERVICES, INC.	NO BID	
ENTECH STAFFING	EXCLUDED	\$15,000.00 Or 15% of annual salary whichever is the lesser amount
GOVERNMENT PROFESSIONAL SOLUTIONS, LLC.	\$ 23,500.00	\$ 19,500.00
JOB IMPULSE	\$ 23,000.00	\$ 20,000.00
MGT OF AMERICA CONSULTING, LLC.	\$ 26,500.00	\$ 25,000.00
PUBLIC SECTOR SEARCH & CONSULTING, INC.	\$ 49,950.00	\$ 42,500.00
REHMANN	\$ 24,500.00	\$ 14,500.00
VIBRUS GROUP, LLC.	\$ 25,000.00	\$ 15,000.00

ITEM 1	DESCRIPTION	PER EVENT FEE
1A	LEVEL 1 RECRUITMENT	\$ 18,500.00
1B	LEVEL 2 RECRUITMENT	\$ 4,950.00

ITEM 2	ADDITIONAL FEES/REIMBURSABLES	RATE/FEE
2A	TRAVEL FEE	\$ 50.00

ITEM 3	EMPLOYEE CLASSIFICATION	HOURLY RATE
3A	PRESIDENT	\$ 125.00
3B	DIRECTOR	\$ 125.00
3C	CONSULTANT	\$ 95.00

**AQUIYEL BUSINESS SERVICES, LLC.
AS-READ BID DETAIL**

RECRUITING SERVICES

ITEM 1	DESCRIPTION	PER EVENT FEE
1A	LEVEL 1 RECRUITMENT	18% MARK UP
1B	LEVEL 2 RECRUITMENT	18.5% MARK UP

ITEM 2	ADDITIONAL FEES/REIMBURSABLES	RATE/FEE
2A	APPLICANT TRAVEL & LODGING	\$ 5,000.00

ITEM 3	EMPLOYEE CLASSIFICATION	HOURLY RATE
3A	MANAGER/ SUPERVISOR	\$ 84.00
3B	RECRUITER	\$ 65.00

**BLUE CHIP TALENT, INC.
AS-READ BID DETAIL**

RECRUITING SERVICES

ITEM 1	DESCRIPTION	PER EVENT FEE
1A	LEVEL 1 RECRUITMENT	\$ 30,000.00
1B	LEVEL 2 RECRUITMENT	\$ 25,000.00

ITEM 2	ADDITIONAL FEES/REIMBURSABLES	RATE/FEE
2A	Travel Expenses (If applicable, if candidate is more than 150 miles away)	\$100 to 2,000
2B	Relocation Package (If applicable, if candidate is relocating from over 50 miles)	\$2,000 to 20,000

**ENTECH STAFFING SOLUTIONS
AS-READ BID DETAIL**

RECRUITING SERVICES

ITEM 1	DESCRIPTION	PER EVENT FEE
1A	LEVEL 1 RECRUITMENT	EXCLUDED
1B	LEVEL 2 RECRUITMENT	\$15,000.00 Or 15% of annual salary - whichever is the lesser amount

ITEM 2	ADDITIONAL FEES/REIMBURSABLES	RATE/FEE
2A	NONE	\$ -

ITEM 3	EMPLOYEE CLASSIFICATION	HOURLY RATE
3A	Director - Licensing and Regulatory	\$120,628 annual
3B	Sr. Deputy Director - Human Services	\$165,562 annual
3C	Chief Deputy Superintendent Education	\$195,719 annual
3D	Sr. Policy Executive - Environmental	\$159,417 annual

GOVERNMENT PROFESSIONAL
AS-READ BID DETAIL

RECRUITING SERVICES

ITEM 1	DESCRIPTION	PER EVENT FEE
1A	LEVEL 1 RECRUITMENT	\$ 23,500.00
1B	LEVEL 2 RECRUITMENT	\$ 19,500.00

ITEM 2	ADDITIONAL FEES/REIMBURSABLES	RATE/FEE
2A	NONE	\$ -

ITEM 3	EMPLOYEE CLASSIFICATION	HOURLY RATE
3A	BRET BAUER, PARTNER	\$ 250.00
3B	CHRIS LOWE, PARTNER	\$ 250.00

ITEM 1	DESCRIPTION	PER EVENT FEE
1A	LEVEL 1 RECRUITMENT	\$ 23,000.00
1B	LEVEL 2 RECRUITMENT	\$ 20,000.00

ITEM 2	ADDITIONAL FEES/REIMBURSABLES	RATE/FEE
2A	N/A	N/A

ITEM 3	EMPLOYEE CLASSIFICATION	HOURLY RATE
3A	TECHNICAL RECRUITER	\$ 35.00

MGT OF AMERICA CONSULTING
AS-READ BID DETAIL

RECRUITING SERVICES

ITEM 1	DESCRIPTION	PER EVENT FEE
1A	LEVEL 1 RECRUITMENT	\$ 26,500.00
1B	LEVEL 2 RECRUITMENT	\$ 25,000.00

ITEM 2	ADDITIONAL FEES/REIMBURSABLES	RATE/FEE
2A	EXPENSES	\$ 1,500.00
2B	ADVERTISING	\$ 5,000.00

ITEM 3	EMPLOYEE CLASSIFICATION	HOURLY RATE
3A	CONSULTANTS	\$ 150.00

**PUBLIC SECTOR SEARCH
AS-READ BID DETAIL**

ITEM 1	DESCRIPTION	PER EVENT FEE
1A	LEVEL 1 RECRUITMENT	\$ 49,950.00
1B	LEVEL 2 RECRUITMENT	\$ 42,500.00

ITEM 2	ADDITIONAL FEES/REIMBURSABLES	RATE/FEE
2A		

ITEM 3	EMPLOYEE CLASSIFICATION	HOURLY RATE
3A		

ITEM 1	DESCRIPTION	PER EVENT FEE
1A	LEVEL 1 RECRUITMENT	\$ 24,500.00
1B	LEVEL 2 RECRUITMENT	\$ 14,500.00

ITEM 2	ADDITIONAL FEES/REIMBURSABLES	RATE/FEE
2A	TRAVEL FOR OUT OF STATE CANDIDATES	PASS THROUGH
2B	SPONSORED ADVERTISEMENT IF REQUESTED	PASS THROUGH
2C	PXT ASSESSMENT	\$ 310.00
2D	LEVEL 1 IN-DEPTH BACKGROUND CHECK	PASS THROUGH

ITEM 3	EMPLOYEE CLASSIFICATION	HOURLY RATE
3A	PRINCIPAL	\$ 365.00
3B	SENIOR MANAGER	\$ 225.00
3C	HR MANAGER	\$ 187.00
3D	SENIOR BUSINESS PARTNER	\$ 145.00
3E	STAFF	\$ 100.00

VIBRUS GROUP
AS-READ BID DETAIL

RECRUITING SERVICES

ITEM 1	DESCRIPTION	PER EVENT FEE
1A	LEVEL 1 RECRUITMENT	\$ 25,000.00
1B	LEVEL 2 RECRUITMENT	\$ 15,000.00

ITEM 2	ADDITIONAL FEES/REIMBURSABLES	RATE/FEE
2A	NONE	

ITEM 3	EMPLOYEE CLASSIFICATION	HOURLY RATE
3A	LEAD RECRUITER	\$ 120.00
3B	LEAD RECRUITER	\$ 120.00
3C	ADMINISTRATION	\$ 75.00
3D	CREDENTIALING	\$ 75.00

RESOLUTION

Document No: ITB-W-1195
Product or Service: Recruitment Services
Requesting Department: Human Resources Department

At a Regular Meeting of the City Council of the City of Warren, County of Macomb, Michigan, held on _____, 2024 at 7 p.m. Local Time in Council Chambers located at Warren Community Center Auditorium, 5460 Arden Ave, Warren, Michigan.

PRESENT: Councilmembers: _____

ABSENT: Councilmembers: _____

The following preamble and resolution were offered by Councilmember _____ and supported by Councilmember _____.

Sealed bids were accepted, publicly opened and read on April 24, 2024.

The following bids have been received by City Council:

BIDDER: **AMOUNT:**

Please see attached bid tabulation

The bid of Amy Cell, LLC., 215 W. Michigan Avenue, Ypsilanti, MI 48097 has been determined to be the low responsible and cost-effective bid for furnishing Recruitment Services for the City of Warren. This contract is termed for one (1) year period with an option to renew for four (4) additional one-year periods, at the same terms and conditions, in an annual amount not to exceed \$75,000.00.

Funds are available in following Account: 101-1220-80100.

IT IS RESOLVED, that the bid of Amy Cell, LLC. is hereby accepted by City Council for a one year period, with options to renew for four (4) additional one-year periods, at the same terms and conditions, and with mutual consent of both parties, in an annual amount not to exceed \$75,000.00.

IT IS FURTHER RESOLVED, that the contract shall become effective when signed by both parties.

IT IS FURTHER RESOLVED, that the Purchasing Agent and/or Mayor and City Clerk are authorized to execute any such documents that are necessary for this approval consistent with the terms of the:

- Bid document
- Contract
- Resolution

and in such form that meets with the satisfaction of the City Attorney if review is required.

AYES: Councilmembers: _____

NAYS: Councilmembers: _____

RESOLUTION DECLARED ADOPTED this ____ day of _____, 2024.

Mindy Moore
Secretary of the Council

INDEPENDENT CONTRACTOR AGREEMENT

This agreement between the City of Warren, a Michigan municipal corporation, whose address is One City Square, Warren, MI 48093 (the City) and independent contractor Amy Cell, LLC. whose address is 215 W. Michigan Ave., Ypsilanti, MI 48197 (the IC) made effective as of _____, sets forth the terms and conditions under which IC will provide search and recruitment services (as defined below) to the City (Agreement).

RECITALS

1. The City desires to engage the services of a firm that specializes in recruitment for local government organizations and has extensive executive-level personnel recruitment experience to conduct national searches leading to the appointment of new non-Civil Service positions as determined in the City's discretion.

2. The City requires a fully-established firm that has been working under its operational name for a minimum of five (5) years in the business of executive search and recruitment, and which has adequate personnel and equipment to perform the Services as indicated in the published Invitation to Bid dated April 9, 2024, the Addendum 1 dated April 12, 2024, and the Addendum 2 dated April 19, 2024 (ITB-W-1195), attached as Exhibit A.

1. The IC has provided references from satisfied local municipalities where the IC has provided similar services over the last three (3) years.

2. The IC desires to conduct a national recruitment search for the City, which includes attracting, interviewing, and recommending candidates to the City and it has submitted a response to ITB-W-1195, which is attached as Exhibit B.

3. The IC has submitted satisfactory evidence that the IC has the practical knowledge and expertise, necessary financial resources, adequate equipment, and experienced and competent personnel and subcontractors to perform the work proposed in ITB-W-1195.

4. The IC has demonstrated that it has the required insurance, as indicated in ITB-W-1195.

5. The parties wish to memorialize their understanding in a binding contract.

NOW THEREFORE, in consideration of the rights, duties, and privileges written below, the parties agree as follows:

1. Term of Agreement. This Agreement becomes effective when signed by both parties and continues for one (1) year with options to extend for four (4) additional one (1) year periods. All extensions require the written mutual consent of both parties.

2. No Exclusive Contract/Additional Services. The IC agrees and understands that this Agreement shall not be construed as an exclusive agreement and that the City may, at any time, secure similar or identical services at its sole option.

3. At Will. This Agreement may be terminated at will by the City upon a minimum of thirty (30) days prior written notice to the IC. In the event of termination, the IC will be compensated for all Services performed and approvable reimbursable expenses in accordance with the bid specifications from the inception date to the termination date. Delivery to the City of all information and materials retained by the IC, affiliates, or subcontractors in performing the Services, whether completed or in progress, is a condition precedent to payment.

4. Services to be Performed. The IC will conduct a national recruitment search, which is to include attracting, interviewing, and recommending candidates for the appointment to new non-Civil Service positions as determined in the City's discretion. The IC agrees to perform all the Level 1 and Level 2 recruitment services described in the Types of Recruitment Services Section on page fifteen (15) of ITB-W-1195 (Services). See Exhibit A.

5. Payment. The IC and the City have meaningfully negotiated the Per Event Fee, the Rate/Fee, and the Hourly Rate set forth in the Pricing Table Section on page seventeen (17) of ITB-W-1195 as the consideration that the City will make for the Services. See Exhibit A.

6. Payment Terms. The City's payment terms are Net 45 days. Time will be computed from the date of complete delivery of Services, as specified, or from the date correct invoices are received in the Office of the City Controller, if the latter is later than the date of delivery. Prices will be considered as net if no cash discount is shown.

Progress payments will be made based on hours of work completed during the engagement in accordance with the firm's fee bid. Interim billings shall cover a period of not less than a calendar month.

The IC will invoice the City monthly. Receipt of invoice by the City is a condition precedent of payment to the IC.

7. Materials. The IC will furnish any materials, equipment, or supplies used to provide the Services.

8. Independent Contractor Status. The parties agree that the IC is an independent contractor and that neither the IC nor the IC's employees or contract personnel are, or shall be deemed to be, employees of the City. The parties acknowledge and agree that the City is entering into this Agreement with reliance on the representations made by the IC relative to its independent contractor status. In its capacity as an independent contractor, the IC agrees to and represents the following:

a. The IC has the right and fully intends to perform services for third parties during the term of this Agreement.

b. The IC has the sole right to control and direct the means, manner, and method by which the Services will be performed.

c. The IC has the right to perform the Services at any place or location and at such times as the IC may determine.

d. The IC has the right to hire assistants as subcontractors or to use employees to provide the Services.

e. The Services shall be performed by the IC, or the IC's employees or contract personnel, and the City shall not hire, supervise, or pay any assistants to help the IC.

f. Neither the IC nor the IC's employees or contract personnel shall receive any training from the City in the professional skills necessary to perform the Services.

g. Neither the IC nor the IC's employees or contract personnel shall be required by the City to devote full time to the performance of the Services.

h. The IC does not receive the majority of its annual compensation from the City.

9. State and Federal Taxes. The City will not withhold FICA (Social Security and Medicare taxes) from the IC's payments or make FICA payments on the IC's behalf or make state or federal unemployment compensation contributions on the IC's behalf or withhold state or federal income tax from the IC's payments. The IC shall pay all taxes incurred while performing services under this Agreement, including all applicable income taxes and, if the IC is not a corporation, self-employment (Social Security) taxes. On demand, the IC shall provide the City with proof that such payments have been made.

10. Fringe Benefits. The IC understands that neither the IC nor the IC's employees or contract personnel are eligible to participate in any employee pension, health, vacation pay, sick pay, or other fringe benefit plan of the City.

11. Worker's Compensation. The City shall not obtain worker's compensation insurance on behalf of the IC or the IC's employees. If the IC hires employees to perform any work under this Agreement, the IC will cover them with worker's compensation insurance and provide the City with a certificate of worker's compensation insurance before the employees begin work.

12. Unemployment Compensation. The City shall make no state or federal unemployment compensation payments on behalf of the IC or the IC's employees or contract personnel. The IC will not be entitled to these benefits in connection

with work performed under this Agreement. If the IC files a petition for and receives unemployment compensation, the total amount of unemployment compensation awarded to and received by the IC shall be deducted from and be an offset against the amount of compensation due and payable to the IC by the City under this Agreement.

13. Insurance. The IC, as an independent contractor, agrees to indemnify, defend, and hold harmless the City from all liability arising out of or in any way related to the IC's performance of services during the term of this Agreement, including any liability resulting from intentional or reckless acts or the acts of the employees or agents of the IC, and agrees to maintain the insurances set forth in the Insurance Requirements Section on page seven (7) of ITB-W-1195. See Exhibit A.

14. Exclusive Agreement. This is the entire Agreement between the IC and the City.

15. Modifying the Agreement. This Agreement may be modified only by a writing signed by both parties.

16. Confidentiality. The IC will not disclose or use, either during or after the term of this Agreement, any proprietary or confidential information of the City without the City's prior written permission except to the extent necessary to perform services on the City's behalf. Proprietary or confidential information includes:

a. The written, printed, graphic, or electronically recorded materials furnished by the City for the IC to use;

b. Business plans, customer lists, operating procedures, trade secrets, design formulas, know-how and processes, computer programs and inventories, discoveries, and improvements of any kind; and

c. Information belonging to customers and suppliers of the City about whom the IC gained knowledge because of the IC's Services to the City. The IC shall not be restricted in using any material that is publicly available, already in the IC's possession, or known to the IC without restriction, or that is rightfully obtained by the IC from sources other than the City. On termination of the IC's Services to the City, or at the City's request, the IC shall deliver to the City all materials in the IC's possession relating to the City's business.

17. Applicable Law. This Agreement shall be governed by the laws of Michigan. Any action in law or equity, brought by either party, shall be brought in a court of law with proper jurisdiction, within Macomb County, Michigan, and shall not be arbitrated.

18. Notices. All notices or other communications required or permitted to be given to a party to this Agreement shall be in writing and delivered to the City at:

The City of Warren Purchasing Division
Attn: Craig Treppa, Purchasing Agent
One City Square, Ste. 425
Warren, MI 48093
ctreppa@cityofwarren.org

And delivered to the IC at:

Amy Cell, LLC
Attn: Amy Cell, President
215 W. Michigan Ave.
Ypsilanti, MI 48197
Amy@amycelltalent.com

The writing shall be (a) personally delivered; (b) sent by certified mail, postage prepaid, return receipt requested; or (c) electronically transmitted. Mail shall be deemed delivered and received on the delivery date, or the date on which delivery is refused by the addressee, in accordance with the U.S. Postal Service's return receipt. An electronic transmission shall be deemed delivered one (1) business day after the electronically transmitted writing is received. The IC will notify the City of a change of address.

19. No Partnership. This Agreement does not create a partnership relationship. The IC does not have the authority to enter contracts on the City's behalf.

20. Assignment and Delegation. The IC may not assign or subcontract any rights or obligations under this Agreement without the City's prior written approval.

21. ITB-W-1195. The terms and conditions set forth in ITB-W-1195 shall be included as part of this Agreement, unless they conflict, in which case, the terms of this Agreement shall govern.

Signatures:

THE CITY OF WARREN

AMY CELL, LLC

By: Lori M. Stone
Its: City Mayor

By: Amy Cell
Its: President

By: Sonja Buffa
Its: Clerk

Exhibit A



Lori M. Stone, Mayor

**Purchasing Division
Office of the Controller**
One City Square, 4th Floor, Suite 425
Warren, Mi 48093-5289

Phone (586) 574-4639
FAX (586) 574-4614

ITB-W-1195

INVITATION TO BID

APRIL 9, 2024

ELECTRONIC BIDS TO FURNISH RECRUITING SERVICES FOR THE CITY OF WARREN ARE BEING ACCEPTED.

ELECTRONIC BIDS MUST BE ENTERED INTO THE BIDNET (MITN) PROCUREMENT SYSTEM ON, OR BEFORE, 12:30 PM, WEDNESDAY, APRIL 24, 2024

PLEASE SEE SPECIAL INSTRUCTIONS ON PAGE TWO (2) OF THE BID FORM

A PUBLIC BID OPENING WILL TAKE PLACE AT 1:00 PM EST ON APRIL 24, 2024 VIA THE "ZOOM APP" WHICH WILL BE HOSTED BY THE CITY COUNCIL OFFICE. PLEASE JOIN THE ZOOM MEETING BETWEEN 12:50 AND 1:00 PM EST, ON THE DAY OF THE BID OPENING IN ORDER TO VIEW OR LISTEN TO THE BID OPENING VIA THE ZOOM APP.

LINK TO ZOOM MEETING:

<https://cityofwarren.zoom.us/j/87597780956?pwd=L4qNfP2rJH33YduAmu1ycyOpBPbYCO.1>

ZOOM CALL-IN #: 1 646 931 3860

ZOOM MEETING ID: 875 9778 0956

ZOOM MEETING PASSCODE: 407011

Addenda, clarifications and changes to the bid documents must be obtained on line by registering (free registration available) for the MITN system as follows: 1) go to www.BidNetDirect.com/MITN, 2) Click on "Register Now", 3) Activate your account & select your registration option. Call 800-835-4603 and press option two (2) to speak live with customer support.

YOU SHOULD REGISTER FOR NIGP CODES

91800 - Consulting Services

91806 - Administrative Consulting

91866 - Human Resources Consulting Services

91875 - Management Consulting

91885 - Personnel/Employment Consulting

96130 - Employment Agency and Search Firm Services

Additional information regarding this bid or any questions can be answered by contacting the Purchasing Agent, Craig Treppa of the City of Warren Purchasing Division preferably by e-mail, ctreppa@cityofwarren.org, subject: ITB-W-1195.

Sincerely,

A handwritten signature in black ink, appearing to read "CT", written over a white background.

**Craig Treppa
Purchasing Agent**

SPECIAL INSTRUCTIONS FOR ELECTRONIC BID SUBMISSION:

The City will require the vendor to perform the following, via the BidNet (MITN) system, within the bid solicitation, in order to have the bid considered for award:

1. The bidder shall complete the bid form in its entirety, sign Page 3 and all other appropriate areas (clauses, etc.), scan the document, and upload the completed document (pages 1-18) with your electronic bid submission.
2. If the Vendor has any questions regarding the steps needed to complete the electronic bid submission, they shall contact the BidNet (MITN) help desk at 1-800-835-4603. Select Option 2 when prompted.
3. Electronic bids must be entered no later than the bid due date and time. The BidNet (MITN) system will prohibit vendors from entering bid information after the scheduled due date/time.
4. The City shall not have access to bid results until after the scheduled due date/time.
5. The bid opening shall be made available to the public via a "Zoom Meeting". Interested parties will need to access the Zoom app and enter the Meeting ID # and the Password in order to obtain access to the public bid opening. Interested members of the public may view or listen to the results at that time.
6. The Zoom Meeting Call-in #, ID# and password for this bid opening can be found on the first page of this bid document.
7. The link to view the bid opening via "Zoom Meeting" can be found on the first page of this bid document.
8. The public shall have the ability to join the Zoom Meeting any time after 12:50 pm EST on the bid due date.
9. The public bid opening via "Zoom" shall occur at 1:00 pm EST on the bid due date.

POINT OF CONTACT FOR QUESTIONS:

All bidders will be held liable to have visited the work site(s) and familiarize themselves with the nature of the work and conditions under which the work will be performed. No extras will be allowed for failure to inspect or to account for working conditions.

Vendors are encouraged to submit any, and all, questions you may have regarding this solicitation via e-mail to Craig Treppa, Purchasing Agent for the City of Warren, at ctreppa@cityofwarren.org. Bidders shall tabulate all questions and submit one inquiry list no later than Tuesday, April 16th, 2024 at 2:00 pm EST. The City of Warren will not respond to questions received after this date and time.

Except as otherwise directed, bidders are not to communicate with other parties within The City of Warren regarding this solicitation without prior written permission from the Purchasing Agent. The City's Purchasing Division is the only office authorized to change any terms, conditions and/or specifications related to this bid.

COMPANY NAME: Amy Cell, LLC

BID PROPOSAL FORM:

The City of Warren is seeking competitive, electronic bids from qualified search and recruitment firms to conduct national searches leading to the selection of new Department Head(s).

DETAILED PRICING:

Please complete the pricing tables on Page seventeen (17).

IT IS MANDATORY FOR ALL BIDDERS TO RETURN THIS SHEET FULLY COMPLETED AND SIGNED BY AN AUTHORIZED REPRESENTATIVE WITH THEIR ELECTRONIC BID. FAILURE TO PROPERLY SIGN IN THE AREA BELOW MAY RESULT IN YOUR BID NOT BEING ACCEPTED.

The undersigned has carefully checked the bid figures and understands that he shall be responsible for any error of omission in this bid offer and is in receipt of all addenda as issued.

Signature of *Amy Cell* **DATE:** 4/19/2024
Authorized Company Representative

Amy Cell COMPANY NAME Amy Cell, LLC
(Print name of Signature)

ADDRESS CITY STATE ZIP CODE
215 W. Michigan Ave Ypsilanti MI 48197

TELEPHONE NUMBER FAX NUMBER E-MAIL ADDRESS
(734)657-0370 n/a amy@amycelltalent.com

WARRANTY (If Applicable)
9 years Amy Cell (734) 657-0370
YEARS IN BUSINESS COMPANY CONTACT PERSON WITH TELEPHONE NUMBER

EXCEPTIONS: Where an exception to any specification is taken, such exception shall be clearly indicated below and along with the specifications attached hereto, shall be considered an integral part of this bid proposal.

No exceptions taken.

COMPANY NAME: Amy Cell, LLC

DISQUALIFICATION:

Failure to comply with the requirements, procedures, and provide information as requested by this document may result in disqualification.

RELATIONSHIP DISCLOSURE:

It is required that any relationship (business or personal) to any City employee or official be disclosed. This includes employment or other professional/personal engagements. The bidder shall not offer any product or service to City personnel as a fringe benefit for doing business with the City. Evidence of this will result in the immediate termination of the contract with the vendor.

VENDOR DISCLOSURE:

The vendor bidding on this project declares that it has not, nor will it, provide gifts, gift certificates, entertainment, favors, or other gratuities to a City official, City employee, agent, or City volunteer, or their families.

The vendor acknowledges that if it violates this policy then the City may terminate the contract with the vendor.

PRICE CLAUSE:

The City requests that prices be held firm for 90 days or bid award, whichever comes first, except for the successful bidder whose prices shall be held firm the entire contract period, which shall be for a one (1) year period with options to extend for four (4) additional one (1) year periods, with mutual consent of both parties.

The bidder shall base the bid amount on all labor, materials, transportation, equipment, services, and insurance necessary to perform the work in conformity with the bid documents, and all addenda to them, as well as compliance with all applicable codes and ordinances. The bid amount must include all incidental items required as part of the work, even if they are not specified or indicated.

At the conclusion of this contract, the awarded firm(s) will be responsible for completing any work that had been authorized by the City during the term of the contract.

Authorized Signature for *Amy Elett*

Pricing Clause

PERFORMANCE:

The City Reserves the right to withhold any, or all, payments until any defects in performance have been satisfactorily corrected.

INVOICING:

Billings are to be generated upon completion of the project, and shall include site location and date of service. The City agrees to pay each invoice within forty-five (45) days of receipt.

Invoices shall be submitted to:

ATTN: PURCHASING DIVISION
ONE CITY SQUARE, STE. 425
WARREN, MI 48093
586-574-4639

COMPANY NAME: Amy Cell, LLC

COMPETENCY OF THE BIDDER:

Bidders will be required to submit satisfactory evidence that they have the practical knowledge and expertise, necessary financial resources, adequate equipment, experienced and competent personnel, and subcontractors to perform the proposed work. The opening and reading of the bid shall not be construed as acceptance of the bidder as a responsible bidder.

The City reserves the right to determine the responsibility of a bidder from its knowledge of the bidder's qualifications or from other sources. The bidder is required to provide the City with any requested information or documentation that will assist the City in determining that they, and their subcontractors, are competent and qualified.

Authorized signature *Amy Elett*
for Competency of the Bidder Clause

WORKMANSHIP:

All work shall be performed in accordance with the best modern practice and workmanship of highest quality. Failure to conform to standards specified by the City shall be considered a breach of the Contract.

Where not more specifically described in any of the various sections of these specifications, workmanship shall conform to all of the methods and operations of best standards and accepted practices of the trade or trades involved, and shall include all items of fabrication, construction or installation regularly furnished or required for completion of the services. All work shall be executed by personnel skilled in their respective lines of work.

CONFIDENTIALITY:

The Firm acknowledges that it may receive confidential information from the City for use in connection with its performance of the Services. The Firm further acknowledges that it may, in the performance of the Services, develop information, including facts, data, and opinions, which are, or in the City's judgment should be, confidential or limited in terms of dissemination. The Firm shall take all precautions necessary to maintain and protect the confidentiality of any such information and to ensure that it shall be used only for the purposes of the Services. All facts, data, and opinions developed by the Firm in the course of its performance of the Services shall be deemed to belong to the City and no such facts, data, or opinions shall be disseminated to anyone for any purpose without the City's express written consent unless required by law. Upon completion of the Services, Firm shall return to the City all material the City supplied to the Firm in connection with the performance of the Services.

COMPANY NAME: Amy Cell, LLC

CONTRACT:

The recommended firm may be required to enter into a formal contract with the City that is consistent with the bid submitted with the City.

The Firm shall include a copy of their proposed contract for inspection by the City Attorney.

The City shall have the right to execute an agreement using the format provided by the recommended firm or by using the City's format.

REFERENCES:

Please list a minimum of four (4) municipalities/companies for which your company has provided similar services in the past three (3) years.

1. Agency: City of Ann Arbor Year: 2020-2022

Address: 301 E Huron St, Ann Arbor, MI 48104

Contact Name: Julie Grand juliebgrand@gmail.com Phone: (734)678-7567

Work Performed: City Administrator, Chief Financial Officer, City Attorney searches.

2. Agency: City of Fraser Year: 2020-2022

Address: 33000 Garfield Rd, Fraser, MI 48026

Contact Name: Amy Baranski amyb@micityoffraser.com Phone: (586)293-3100 x110

Work Performed: HR department support to 70 employees and 100+ retirees, filled approximately 20 positions, restructured leadership team, recruited interim City Manager.

3. Agency: Scio Township Year: 2021-2022

Address: 827 North Zeeb Rd, Ann Arbor, MI 48103

Contact Name: Kathy Knol kknol@sciotownship.org Phone: (734) 369-9400

Work Performed: Township Administrator, Finance Director, IT Manager, HR Manager searches.

4. Agency: City of St Clair Shores Year: 2022

Address: 27600 Jefferson Ave, St Clair Shores, MI 48081

Contact Name: Chris Vitale vitalec@scsmi.net Phone: (586) 801-4732

Work Performed: City Manager search

COMPANY NAME: Amy Cell, LLC

INSURANCE REQUIREMENTS:**INSURANCE CERTIFICATE MUST BE SUBMITTED BY THE INSURANCE AGENCY, NOT THE PROPOSER.**

The awarded vendor shall be required to provide the City with certificates of insurance naming the City of Warren, City of Warren Municipal Building Authority, Downtown Development Authority, Tax Increment Finance Authority, the 37th District Court, all elected appointed officials, employees and volunteers as individuals acting within the scope of their authority, AS AN ADDITIONAL INSURED.

It is understood and agreed by naming the City of Warren as additional insured, coverage afforded is considered to be primary, and any other insurance the City of Warren may have in effect shall be considered secondary and/or excess.

Additionally, the awarded vendor shall provide language, within the "Description of Operations" section, that "AGREES TO WAIVE THEIR INSURER'S RIGHT OF SUBROGATION UNDER ITS POLICIES".

The awarded vendor shall provide the following coverage and limits (Sub-contractors utilized by the awarded bidder shall be subject to these same conditions).

COMMERCIAL GENERAL LIABILITY:

The following coverage is part of the General Liability policy:

Policy should be on an OCCURRENCE BASIS WITH COMBINED SINGLE LIMITS.

General Aggregate	\$2,000,000
Products/Completed Operations Aggregate	\$1,000,000
Personal & Advertising Injury	\$1,000,000
Each Occurrence	\$1,000,000
Fire Damage-Any one fire	\$ 50,000
Medical Expense-Any one person	\$ 5,000
Per project aggregate limit, Independent contractor's coverage, Broad form property damage Blanket contractual liability coverage	

AUTOMOBILE LIABILITY:

Automobile liability insurance coverage shall be \$1,000,000 combined single limit for any auto and include hired autos and non-owned autos.

WORKERS' COMPENSATION INSURANCE:

Workers' compensation insurance shall be statutory under the State of Michigan Workers' Compensation Act.

PROFESSIONAL LIABILITY (ERRORS AND OMISSIONS) INSURANCE:

Professional liability insurance coverage shall be \$1,000,000.00

UMBRELLA LIABILITY POLICY:

Umbrella Liability shall be \$2,000,000 and be "following form"

Coverage shall be provided by a carrier(s) rated A- or better by A.M. Bests.

Insurance certificates shall contain a provision to the effect that the insurance company SHALL NOTIFY the City at least thirty (30) days prior to CANCELLATION OR MATERIAL CHANGE of the insurance.

- (X) Can meet insurance as indicated.
 () Cannot meet but offer the following

Authorized signature for Amy Cell, LLC

Insurance Clause

COMPANY NAME: Amy Cell, LLC

GENERAL CONDITIONS (Effective November 15, 2022)**SIGNATURE**

Bids and all information requested of the vendor shall be entered in the appropriate space on the bid form and Signature Page. Failure to do so may disqualify your offer.

An authorized officer or employee of the vendor shall sign all bids.

BID SUBMISSION

Bids shall be submitted electronically by the date specified and at or prior to the time specified to be considered. Late bids, sealed, e-mail, telegraphic, or telephone bids will NOT be accepted. Bids received after 12:30 pm of the date they are due will not be accepted.

RELATIONSHIP DISCLOSURE

It is required that any relationship (business or personal) to a City employee or official be disclosed. This includes employment or other professional engagements.

ALTERATION OF BID DOCUMENTS

Vendor **changes or alterations to the bid documents, including the specification, may result in the bid being considered non-responsive** and/or the Bidder being debarred. The only authorized vendor changes to the bid documents will be in the areas provided for the Bidder's response including the "Exceptions" section of the bid and on separate attached sheets submitted by the vendor. Vendor shall clearly identify product offered and deviations from the specification. If a change or alteration to the bid document is undetected, and the bid is awarded the contract, the original terms, conditions, and specification in the authorized version of the bid document will be applicable during the terms of the contract. Bidders are responsible for ensuring they have obtained all relevant documents including amendments, clarifications, changes, drawings, etc. as made available by the City.

PRICES

Prices quoted shall be for new products in current production unless otherwise specified. Where refurbished or discontinued items are offered they shall be clearly identified as such.

Prices quoted shall be exclusive of any rebates due the City. Any rebates the City may be entitled to should be shown as a separate line item and include expiration date.

Corrections and/or modifications received after the bid closing time specified will not be accepted.

Unit prices prevail.

All information shall be entered in ink or typewritten. Mistakes may be crossed out and corrections inserted before submission of your bid. The person signing the bid shall initial corrections in ink.

All prices will be F.O.B. DESTINATION, INCLUDE ALL DELIVERY AND ANY ADDITIONAL CHARGES and remain in effect as specified in the bid.

COMPANY NAME: Amy Cell, LLC

AWARD

Unless otherwise stated in the bid documents, the City cannot guarantee exclusivity of the contract for the proposed products or services.

Award of the bids shall be based upon a combination of factors, including but not limited to, adherence to bid requirements, references and any other factors that may be in the City's best interest.

The City reserves the right to reject any and all bids, and to waive any defect or irregularity in bids. The City reserves the right to accept and separate items in the bid and to accept the bid that, in the opinion of the City, is to the best advantage and interest of the public we serve. The City also has the right to re-solicit bids if it is deemed to be in the best interest of the City.

The City reserves the right to reject low bids which have major deviations from our specifications; to accept a higher bid which has only minor deviations. By signing the bid, Bidders agree to accept a split award unless the Bidder clearly indicates that it takes Exception. The bid will be awarded to that responsible, responsive firm whose bid, conforms to this solicitation and will be most advantageous to the City, with regard not only to price but also to availability of product, location and quality of product considered.

The City reserves the right to award all line items, to make no award or to award on an individual line item basis, whichever is deemed to be in the best interest of the City.

Time of delivery may be a consideration in the award.

The City reserves the right to consider as unqualified to perform the contract any bidder who does not habitually perform with its own forces seventy-five (75%) of the work involved.

TERMINATION

1. Failure to Perform. The City may terminate a bid award for the failure to perform a term of the bid specifications to the satisfaction of the City. The City shall provide ten (10) days advance written notice to the Awarded Vendor for the failure to perform services or for the violation of any other term of the bid specifications. Unless futile or the violation is recurring, the City shall provide notice and the opportunity to cure the violation prior to termination. Such notice to cure shall be given in writing by first-class mail. In the event of a dispute, or in order to avoid interruption of service, the City may engage another to perform the work and the Awarded Vendor shall be responsible for any costs the City incurs as a result of the Awarded Vendor's violation. The City may withhold payment to offset any damages the City incurs as a result of the Awarded Vendor's violation.

2. At Will. A bid award may be terminated at will by the City upon a minimum of thirty (30) days prior written notice to the Awarded Vendor. In the event of termination as provided in this subsection, the Awarded Vendor will be compensated for all services performed and approvable reimbursable expenses from the inception date to the termination date provided the services performed and the expenses were provided in accordance with the bid specifications. Payment shall be made upon the Awarded Vendor delivering to the City all information and materials retained by the Awarded Vendor, affiliates, or subcontractors in performing the services described in the bid specifications, whether completed or in progress.

3. MISREPRESENTATION. In addition, the City may reject this Bid, or cancel a contract with an Awarded Vendor, if there is evidence of any misleading or intentionally fraudulent information or documents provided in connection with this Bid.

COMPANY NAME: Amy Cell, LLC

SPECIFICATION

Brand names and numbers, when used, are for reference to indicate the character or quality desired, unless specifically stated "No Substitutes".

Alternate items of the same quality will be considered, provided your offer clearly describes the article. Offers for alternate items shall state the brand and number, or level or quality. When the bidder does not state brand, or level of quality, it is understood the offer is exactly as specified.

All products and services shall be in accordance with all applicable federal, state and local statutes, rules, ordinances, etc.

All personnel shall have the appropriate licenses with endorsements for the work performed.

In addition, any personnel driving a vehicle on City property shall have the appropriate valid driver's license and have or exceed minimum statutory insurance requirements.

E-VERIFY

Any bidder, attesting to his bid by signature, is affirming that the Bidder has registered with, participates in and utilizes the E-Verify Program (or any successor program implemented by federal Department of Homeland Security and Social Security Administration) to verify the work status of all newly hired employees employed by the Bidder.

NON-IRAN LINKED BUSINESSES

By signing below, Bidder certifies and agrees on behalf of Bidder and the company submitting this bid the following: (1) that the Bidder is duly authorized to legally bind the company submitting this bid; (2) that the company submitting this bid is not an "Iran linked business," as defined in Section 2(e) of the Iran Economic Sanctions Act, being Michigan Public Act No. 517 of 2012; and (3) that Bidder and the company submitting this bid will immediately comply with any further certifications or information submissions requested by the City in this regard.

ASSIGNMENT OF AGREEMENT - OTHER CONTRACTORS.

The Awarded Vendor shall not assign the contract or any part thereof without the written consent of the City.

PERIOD AGREEMENTS

No Exclusive Contract/Additional Services. The Awarded Vendor agrees and understands that the contract shall not be construed as an exclusive agreement and that the City may, at any time, secure similar or identical services at its sole option.

Any contract executed pursuant to this Bid, which is for a specific term shall include for an extension of the contract term, at the option of the City, as follows:

The City shall have the sole option to extend the contract herein for a period of two months by written notice to the Awarded Vendor exercising the option served at least ten days prior to the expiration date of the contract. In the event such option is exercised by City, all of the provisions of the contract shall remain in full force and effect other than the date of expiration of the contract.

The quantities have been estimated for bid award purposes and may be estimated based on past usage. The quantities may increase or decrease and the City makes no representation as to guarantee of usage. The quantities are estimated on an annual basis.

COMPANY NAME: Amy Cell, LLC

PAYMENT TERMS

The City's normal payment terms are Net 45 days in connection with cash discounts specified with this bid. Time will be computed from the date of complete delivery of services, supplies, or equipment, as specified, or from the date correct invoices are received in the Office of the City Controller, if the latter is later than the date of delivery. Prices will be considered as net if no cash discount is shown.

Progress payments will be made on the basis of hours of work completed during the course of the engagement in accordance with the firm's fee bid. Interim billings shall cover a period of not less than a calendar month.

MICHIGAN FREEDOM OF INFORMATION ACT (FOIA)

All costs incurred in the preparation and presentation of this bid, in any way whatsoever, shall be wholly absorbed by the Bidder. All supporting documentation shall become the property of the City unless requested otherwise at the time of submission. Michigan FOIA requires the disclosure, upon request, of all public records that are not exempt from disclosure under Section 13 of the Act, which are subject to disclosure under the Act. Therefore, confidentiality of information submitted in response to this RFP is not assured.

EQUAL OPPORTUNITY CLAUSE

This contract requires adherence to the equal opportunity clause, 41 CFR § 60-1.4.

EXCEPTIONS TO THE BID SOLICITATION

Each individual/group shall provide a list of Exceptions taken to this bid. Any Exceptions taken shall be identified and explained in writing. An Exception is defined as the individual/group's inability to meet a mandatory requirement or exceed a requirement in the manner specified in the bid solicitation. If the Bidder provides an alternative solution when taking an Exception to a requirement, the benefits of this alternative solution shall be explained. The City reserves the right to accept or reject any Exception whichever is deemed to be in the best interest of the City.

WITHDRAWAL OF BID

Bidders may withdraw their bids by submitting a written request over the signature of an authorized individual to the Purchasing Department any time prior to the submission deadline. Bidders may thereafter submit a new bid prior to the deadline. Modification or withdrawal of the bid in any manner, oral or written, will not be considered if submitted after the deadline.

DEFAULT TO CITY

It is understood that any Bidder who is in default to the City at the time of opening its bid shall have its bid declared null and void.

BIDDER DISCLOSURE

The Bidder declares that it has not, nor will it, provide gifts, gift certificates, entertainment, favors, or other gratuities to a City official, employee, agent, or volunteer, or to their families.

The Bidder acknowledges that if it violates this policy then the City may terminate the contract with the Bidder.

COMPANY NAME: Amy Cell, LLC

INDEMNITY CLAUSE

To the fullest extent permitted by law, the Bidder expressly agrees to indemnify and hold City and its Affiliates harmless against all losses and liabilities arising out of or related to bodily injury or property damages based upon any act or omission, negligent or otherwise, of Bidder or anyone acting on Bidder's behalf in connection with or incident to the work to be performed hereunder, except that Bidder shall not be responsible to indemnify the City for losses or damages caused by or resulting from the City's sole negligence.

For the purposes of this indemnity clause, "City" shall mean the City, its Affiliates, and their elected and appointed officials, employees, authorities, boards and commissions and volunteers working on behalf of the City and its Affiliates; "losses and liabilities" shall mean loss, cost, expense, damage, liability or claims, whether groundless or not; "breach, misappropriation or unauthorized use of data" shall mean copyright, patent, trademark or other intellectual property infringement or unauthorized use of license, software, programs, product, manuals or instructions; "personal injury" shall mean false arrest, erroneous service of civil papers, false imprisonment, malicious prosecution, assault and battery, libel, slander, defamation of character, discrimination, mental anguish, wrongful entry or eviction, violation of property or deprivation of rights, privileges or immunities secured by the constitution and laws of the United States of America or the State of Michigan, for which Vendor may be held liable to the injured party in any action at law, suit in equity or other proceedings for redress; "bodily injury" shall mean bodily injury, sickness or disease (including death resulting at any time there from) mental anguish and mental injury which may be sustained or claimed by any person or persons; and "property damage" shall mean the damage or destruction of any property, including the loss of use thereof.

The Bidder's obligation to indemnify and hold the City and its Affiliates harmless shall include, but not be limited to (1) the obligation to defend the City and its Affiliates from any such suit, action or proceeding, and (2) the obligation to pay any and all judgments which may be recovered in any such suit, action or proceeding, and/or any and all expenses, including but not limited to costs, attorney fees and settlement expenses which may be incurred.

APPENDIX A OF TITLE VI PLAN

During the performance of this contract, the contractor, for itself, its assignees, and successors, in interest (hereinafter referred to as the "contractor") agrees, as follows:

1. COMPLIANCE WITH REGULATIONS. The contractor shall comply with Regulations relative to nondiscrimination in Federally-assisted programs of the Department of Transportation, Title 49, Code of Federal Regulations, Part 21, as they may be amended from time to time (hereinafter referred to as the Regulations), which are herein incorporated by reference and made a part of this contract.

2. NONDISCRIMINATION. The contractor, with regard to the work performed by it during the contract, shall not discriminate on the grounds of race, color, sex, or national origin in the selection, retention, and treatment of subcontractors, including procurements of materials in the discrimination prohibited by Section 21.5 of the Regulation, including employment practices when the contractor covers a program set for in Appendix B of the Regulations.

COMPANY NAME: Amy Cell, LLC

3. SOLICITATION FOR SUBCONTRACTS, INCLUDING PROCUREMENTS OF MATERIALS AND EQUIPMENT.

In all solicitations either by competitive bidding or negotiation made by the contractor for work to be performed under a subcontract, including procurements of materials or leases of equipment, each potential subcontractor or supplier shall be notified by the contractor of the contractor's obligations under the contract and the Regulations relative to nondiscrimination on the grounds of race, color, sex, or national origin.

4. INFORMATION AND REPORTS. The contractor shall provide all information and reports required by the Regulations, or directives issues pursuant thereto, and shall permit access to its books, records, accounts, other sources of information, and its facilities as may be determined by the State Highway Department or the Federal Highway Administration to be pertinent to ascertain compliance with such Regulations or directives. Where any information required of a contractor is in the exclusive possession of another who fails or refuses to furnish this information, the contractor shall so certify to the State Highway Department or the Federal Highway Administration, as appropriate, and shall set forth what efforts it has made to obtain the information.

5. SANCTIONS FOR NONCOMPLIANCE. In the event the contractor's noncompliance with the nondiscrimination provisions of this contract, the State Highway Department shall impose such contract sanctions as it or the Federal Highway Administration may determine to be appropriate, including, but not limited to:

- a. Withholding payments to the contractor under the contract until the contractor complies and/or
- b. Cancellation, termination or suspension of the contract, in whole or in part.

6. INCORPORATION OF PROVISIONS. The contractor shall include provisions of paragraphs (1) through (6) in every subcontract, including procurement of material and leases of equipment, unless exempt by the Regulations, or directives issued pursuant thereto. The contractor shall take such action with respect to any subcontract or procurement as the State Highway Department or the Federal Highway Administration may direct as a means of enforcing such provisions including sanctions for noncompliance: provided, however, that, in the event a contractor becomes involved in, or is threatened with, litigation with a subcontractor or supplier as a result of such direction, the contractor may request the State Highway Department to enter into such litigation to protect the interests of the State, and, in addition, the contractor may request the United States to enter into such litigation to protect the interests of the United States.

SAFETY DATA SHEETS

IMPORTANT: All City purchases require **SAFETY DATA SHEETS** where applicable, in compliance with the Occupational Safety and Health Administration (OSHA) Hazard Communication Standard.

THE ABOVE GENERAL CONDITIONS ARE CONSIDERED IN FORCE UNLESS SPECIFICALLY ADDRESSED IN ANOTHER SECTION OF THE BID DOCUMENT

We have read and acknowledge the above GENERAL CONDITIONS



(Signature)

COMPANY NAME: Amy Cell, LLC

MINIMUM SPECIFICATIONS FOR RECRUITING SERVICES:**PURPOSE:**

The City of Warren is seeking electronic bids from qualified executive Search and Recruitment firms to conduct national searches leading to the selection of new Department Head(s) for the City.

QUALIFICATIONS OF THE FIRM:

The selected executive search firm shall specialize in recruitment for local government organizations, as defined in the Scope of Services, and/or have extensive executive-level personnel recruitment experience.

Firms must demonstrate that they, or the principals assigned to the project, have successfully completed engagements similar to those specified in the Scope of Work section of this document and to organizations similar in size and complexity to the City of Warren. Interested firms must submit the price proposed to charge the City for providing the required services and/or items, including all fees and costs, and how they are calculated.

MANDATORY REQUIREMENTS:

To be considered for award, the vendor must meet the following requirements:

- Bidder shall be a fully-established business operating under its submittal name for a minimum of five (5) years in the appropriate field of work;
- Bidder shall have adequate personnel to perform the services as indicated in this bid specification;
- Bidder shall possess appropriate equipment to perform the requested service;
- Bidder must provide four (4) references where the firm has provided similar services over the last three (3) years;
- Bidder shall have the proper insurance, as indicated in this bid document.

SCOPE OF SERVICES:

The contractor shall perform all Services described in the Types of Recruitment Services Section on Page fifteen (15) of the bid form.

The contractor will conduct a national recruitment search, which is to include attracting, interviewing, and recommending candidates to the City of the requested positions.

a **COMPANY NAME:** _____

TYPES OF RECRUITMENT SERVICES:**LEVEL 1:**

1. Comply with nondiscrimination provisions established by the EEOC and CCRD;
2. Working with the Mayor and Leadership Team to develop characteristics and attributes of the successful candidates, selection criteria, and recruitment process;
3. Provide a compensation study of the requested position;
4. Developing recruitment strategies and timelines along with targeted recruitment of qualified and experienced individuals;
5. Create and post announcement of position;
6. Providing initial screening of all applications against the qualifications required in the job description;
7. Conduct reference checks and interviews with qualified applicants;
8. Select the top applicants;
9. Report findings and recommend applicants to the City for interviews;
10. Developing and coordinating a final selection process with the Mayor, including interviews with Mayor and Leadership staff;
11. Assist the City with compiling interview questions;
12. Conduct Full background screening and share results with the City's Human Resources Department;
13. Assist with offer to selected applicant;
14. Providing timely notification and any necessary follow up and feedback to all candidates not selected for the position.

LEVEL 2:

1. Comply with nondiscrimination provisions established by the EEOC and CCRD;
2. Working with the Mayor and Leadership Team to develop characteristics and attributes of the successful candidates, selection criteria, and recruitment process;
3. Provide a compensation study of the requested position;
4. Developing recruitment strategies and timelines along with targeted recruitment of qualified and experienced individuals;
5. Create and post announcement of position;
6. Providing initial screening of all applications against the qualifications required in the job description;
7. Conduct reference checks and interviews with qualified applicants;
8. Select and present the top qualified applicants to the City so the City can conduct interviews;
9. Conduct Full background screening and share results with the City's Human Resources Department;
10. Providing timely notification and any necessary follow up and feedback to all candidates not selected for the position.

COMPANY NAME: Amy Cell, LLC

QUESTIONNAIRE:

1. Provide your Company's Name, Address, Phone Number and contact person.
2. When was your firm established?
3. How many employees does your company staff on a full and part-time basis?
4. Where is the location of the office(s) from which the work on this engagement(s) is to be performed?
5. Name all other persons who will be directly responsible for the City of Warren's account, state their experience and qualifications (include resumes if available).
6. Is your agency an Equal Opportunity Employer?
7. Are you able to meet the insurance requirements (please include a copy of a current insurance certificate)?
8. Describe the components and features of your proposed Recruitment Services.
9. List any additional services that your company provides that are not included in the Level 1 and Level 2 Scopes of work.
10. What advertising sources will your firm utilize to post position announcements?
11. How in-depth are your reference checks?
12. Discuss what your full background screening includes.
13. How will interviews be conducted by your firm for Level 1 services (video, in person, etc)?
14. Please provide a sample of your proposed contract, if applicable.
15. Complete the Pricing Tables on Page seventeen (17) of the bid form.

COMPANY NAME: Amy Cell, LLC

PRICING TABLE:

Please complete the pricing table below.

ITEM 1. Please list the price for providing Level 1 and Level 2 Recruitment Services. This price is to cover all aspects of the Recruitment Services as listed above, less reimbursable expenses.

ITEM 2. Please list any additional fees/reimbursables that your firm will be charging the City, along with the corresponding cost (rate) that will be charged the City for these fees/reimbursables.

ITEM 3. Please provide hourly rates for those in your firm that will be providing Recruitment Services. These rates shall only be used in the event the City requests additional services that are not covered in the Scope of Work.

ITEM 1	DESCRIPTION	PER EVENT FEE
1A.	Level 1 Recruitment	\$18,500
1B.	Level 2 Recruitment	\$4,950

ITEM 2	ADDITIONAL FEES/REIMBURSABLES	RATE/FEE
2A.	Travel Fee	\$50.00
2B.		\$
2C.		\$
2D.		\$

ITEM 3	EMPLOYEE CLASSIFICATION	HOURLY RATE
3A.	President	\$125.00
3B.	Director	\$125.00
3C.	Consultant	\$95.00
3D.		\$

COMPANY NAME: Amy Cell, LLC

CHECK LIST FOR BIDDERS**MISTAKES OR OMISSIONS CAN RESULT IN THE REJECTION OF YOUR BID.**

- _____ Is your electronic bid **PROPERLY SIGNED** on the **AUTHORIZED REPRESENTATIVE** portion of the **BID FORM, AND ALL CLAUSES AS INCLUDED IN THE BID DOCUMENT?**
- _____ If required, have you entered a unit price for each bid item? (Unit Price governs)
- _____ Have you uploaded the complete document via the BidNet (MITN) system with your electronic submission?
- _____ Late bids will **NOT** be considered. **Bids must be received by the Purchasing Division before 12:30 P.M., Wednesday, on the date specified.**

COMPANY NAME: Amy Cell, LLC

Exhibit B

Recruiting Services: Recruitment Services Firm Proposal

Prepared for City of Warren



Presented by Amy Cell, LLC

April 24, 2024



Craig Treppa, Purchasing Agent
City of Warren
One City Square
Warren, MI 48093

Dear Mr. Treppa,

Thank you for the opportunity to submit this proposal to assist the City of Warren in its pursuit for a qualified, experienced, professional recruitment services firm to conduct national searches leading to the selection of new Department Head(s).

As you look through this proposal, you will find that we bring extensive experience with executive searches in the public and private sectors and we are committed to providing you exceptional service and sharing with you our passion for Michigan communities. My hope is that upon review you will find us to be an excellent fit for this engagement.

We believe that we are the right partner for the City of Warren due to the following attributes which we will detail in the attached proposal:

- ***Passion for community service*** - Our team has worked for government, economic development and community development organizations. We are passionate about supporting Michigan's communities!
- ***Local knowledge makes for better marketing*** - We get to know the communities we are working with, through research and one on one meetings.
- ***Consensus builders*** - We will interview the Mayor and Leadership Team and align them on the ideal candidate profile.
- ***Top notch candidates*** - Our combination of strategic marketing and targeted outreach results in a robust pool of qualified and motivated candidates. We then winnow the pool down to a short list of candidates through a thorough vetting of the candidates' background and accomplishments.
- ***Diversity, equity, inclusion and belonging*** - We strive to develop candidate pools that are diverse and intentionally create a marketing plan and assessment strategy that is as inclusive as possible. Two of our team members have DEI certifications and our own team is rich in diversity.
- ***Customized approach*** - Each of our executive search engagements is unique. We focus on the key experiences, leadership style, and managerial competencies desired by the group of stakeholders that we interview. We create a tailored profile, service offering and communication approach that fits with your needs. Our extensive experience with planning and project management and transparent communication style will help the Mayor and Leadership Team through the experience as smoothly as possible.

- **Transition support** - We are committed to the success of your new team member, and know how important the onboarding experience is for the organization. We provide onboarding plan development support, and offer a 360 degree feedback report after six months.
- **Our team** - We have a team of 21 highly qualified and diverse recruiters and HR experts.

Since our inception in 2015, we have supported hundreds of employers, communities, and job seekers with customized HR and recruiting services. Our team of seasoned professionals brings expertise and knowledge in the areas of municipal recruiting, human resources, economic development, project management, and marketing. We would be honored to work with the City of Warren on this important endeavor.

Please feel free to contact me with any questions. Thank you very much for the opportunity to share our interest in this engagement.

Best regards,

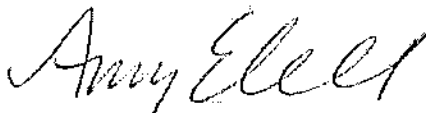

Amy Cell
President, Amy Cell, LLC
734-657-0370
Amy@AmyCellTalent.com

Amy Cell, LLC is a certified Women-Owned Business, proud recipient of the 2022 Michigan Celebrates Small Business 50 Companies to Watch Award (SBAM), 2022 and 2023 Ann Arbor SPARK FASTTRACK Award, and a Gold Resource Partner of MISHRM.

Amy Cell, LLC is an equal opportunity employer.

Table of Contents

A. Qualifications	5
Type of Business	5
History	5
Why Us?	5
Municipal / Public Sector Clients We Have Served	6
Examples of Prior Engagements	8
City of Ann Arbor	8
City of Fraser	9
City of St. Clair Shores	9
Diversity Results	10
References	10
B. Recruitment Work Plan	11
Step Two - Market the Posting to the Right People	12
Step Three - Thoroughly Access Applicants	12
Step Four - Interviews	12
Step Five - Negotiation	12
Step Six - Transition Support	12
Proposed Timeline	13
Key Personnel	14
Our Team	14
Background Checks	15
Reference Checks	15
C. Costs	16
Price Clause	17
Placement Guarantee Terms	18
Payment Terms	18
D. Attachments	19
ATTACHMENT I - Non-Iran Linked Business Confirmation	20
ATTACHMENT II - Certification of Insurance	21
ATTACHMENT III - Addendums 1 and 2	22
ATTACHMENT IV - Team Resumes	23

A. Qualifications

Type of Business

Amy Cell, LLC of 215 W. Michigan Avenue, Ypsilanti, Michigan 48197, operates as a Limited Liability Corporation in the State of Michigan. As a registered LLC in Michigan, we are licensed to operate in the State of Michigan. We provide recruiting, human resources consulting, and career coaching services. We are in good standing with the state of Michigan and have all the necessary licenses and certifications to be able to perform the work indicated in this RFP. The contact person for this proposal is Amy Cell. She can be reached at 734-657-0370 or amy@amycelltalent.com.

History

Since our founding in March of 2015, Amy Cell, LLC has conducted over 1400 searches, including recruitment for 100+ executive and key leadership roles, such as CEOs, City Managers, Executive Directors, Vice Presidents, and other C-Suite roles. In addition to our strong track record of success in both the public and private sectors, Amy Cell brings significant relevant experience to municipal/public sector recruiting, having served as Senior Vice President of Talent Enhancement at the Michigan Economic Development Corporation (MEDC), and as Vice President Talent Enhancement for Ann Arbor SPARK. In these roles, Amy was responsible for programs in talent attraction, retention and development at regional and state levels, and was integral in the design and implementation of talent programs to benefit Michigan employers and citizens (e.g., job seekers, apprentices, displaced workers). Through this decade of public service, Amy Cell established a large professional network and national reputation as a thought leader in talent attraction. The firm's commitment to client satisfaction and a positive jobseeker experience has led to strong growth, and our firm is proud to have all but one of our employees based in Michigan.

Why Us?











Here are the reasons that Councils, Commissions and Boards have trusted us to help them with one of their most important duties:

- We are experts in recruiting and sourcing. We have our own database of 1000+ municipal professionals, and send out monthly communications. We have four LinkedIn recruiter licenses so that we can effectively target top-notch talent, and ensure a diverse applicant pool.
- We are well versed in applicable laws including the Open Meetings Act and Freedom of Information Act.
- In addition to talent acquisition support, we provide HR consulting services to municipal clients, such as training programs, performance review management and have been the outsourced HR function for a municipality. We have had a team member serve as Acting City Manager, and have a team member that

was a long serving local government employee. Thus we understand the day to day activities of local government.

- We have a strong marketing team that is well versed in social media and media relations. We will prepare press releases as directed by the City Council, Administration, HR and Department Heads to support community engagement.
- We focus on success - we can provide a structured onboarding experience to help the new employee hit the ground running. We also offer a 360 degree feedback review after six months to help address any issues to ensure that the new employee has an accurate understanding of what they should keep, stop and start doing.

Municipal / Public Sector Clients We Have Served

Municipal / Public Clients We Have Served		
 Bedford Township	 City Ann Arbor	 City of Clawson
 DEARBORN City of Dearborn	 EASTPOINTE MICHIGAN City of Eastpointe	 FARMINGTON HILLS Michigan City of Farmington Hills
 City of Fraser	 City of Grand Rapids	 GROSSE POINTE City of Grosse Pointe
 Holland MICHIGAN City of Holland	CITY OF JACKSON MICHIGAN City of Jackson	 KENTWOOD Michigan City of Kentwood

 City of Livonia	 City of Madison Heights	 City of Norton Shores
 City of Rochester Hills	 City of St. Clair Shores	 CITY OF TRAVERSE CITY City of Traverse City
 City of Yale	 City of Ypsilanti	 Independence Township OAKLAND COUNTY, MICHIGAN
 Lapeer County Lapeer County	 Lapeer County Road Commission	 Macatawa Area Express Macatawa Area Express
 Macomb Township	 Redford Township	 Scio Township
 Village of Almont Village of Almont	 Village of Capac Village of Capac	 Village of Dundee Village of Dundee
 Washtenaw County Conservation District Washtenaw County Conservation District	 WB Parks WB Parks	

Examples of Prior Engagements

Below is a sample of recent relevant engagements

City of Ann Arbor

Engagements: Amy Cell, LLC has been a key talent resource for the City of Ann Arbor, completing multiple, successful executive searches since 2020. These searches include: **City Administrator** search in June 2020 which resulted in 268 candidates and 3 finalists; **Chief Financial Officer** search in January 2021 resulted in 89 candidates and 4 finalists; **City Attorney** search in July 2021 which resulted in 19 candidates and 1 finalist; and **Director of Human Resources** search in June 2022 which resulted in 95 candidates and 2 finalists.

In addition to completing City Administrator and City Attorney Performance reviews (2020, 2022) and successfully recruiting for a senior staff position in the Public Works department, Amy Cell, LLC also provided organizational development support by designing and implementing 360 feedback assessments for key leaders.

May 25, 2022

"As part of our City Council's Administration Committee, I have enjoyed working closely with Amy Cell on a number of executive level searches. In a competitive recruitment environment shared by all municipalities, Amy was able to present a number of viable candidates for each position - even when a known internal candidate existed. She presented clear, cost-effective plans that were thorough, efficient, and through supplemental materials such as video interviews, provided valuable insight into our candidates.

In addition to her human resources expertise, I appreciated that Amy Cell took the time to capture our council, staff, and community priorities. This understanding of local context has undoubtedly contributed to our successful recruitment efforts."

Fmr Ann Arbor Mayor Pro Tem Julie Grand

City of Fraser

Engagement: In July of 2020 we were selected by the City of Fraser over 5 other firms to provide an independent HR department to support approximately 70 employees and 100+ retirees. During the following 18 months we filled approximately 20 positions, restructured the leadership team, recruited an interim City Manager to address short term issues as well as the permanent City Manager. Additional HR projects included implementation of the BS&A HR module, developed a new handbook, oversaw benefits administration and open enrollment, developing new performance review processes, updating all job descriptions, creating a new compensation structure, and launching an employee newsletter. Additionally, Amy Cell was appointed Acting City Manager at one point during the leadership transitions.

Fraser City Council Meeting, February 10, 2022

"Our vision when we started with Amy Cell hit some major road blocks because some things happened we weren't anticipating and you tackled those with such grace and such dignity and found us candidates."

Fraser City Council Member Amy Baranski

"I just want to thank you and tell you what a privilege and honor it has been to work with you. You have impressed me repeatedly."

Fraser City Council Member Amy Baranski

"Amy, I just want to thank you for everything you have done for us. You accomplished not only what we were looking for, you went beyond that."

Fraser City Council Member David Winowiecki

"Amy, I also wanted to thank you. I feel you were objective and fair, knowledgeable, great people skills. You were exactly what we needed when you came to help us."

Fraser City Council Member Kathy Blanke

City of St. Clair Shores

Engagements: We conducted two successful City Manager searches, one in 2019 and most recently in February 2022. A summary of the searches is as follows: the City Manager search in 2019 which resulted in seven

candidates presented to Council, four finalists selected for in person interviews. The City Manager search in February 2022 resulted in ten candidates presented to Council and four finalists.

St Clair Shores City Council Meeting, April 4, 2022

"Amy Cell and her office did a great job at preparing us and giving us the right candidates to select from."

St Clair Shores Council Member Candice Rusie

"It's been a pleasure again to work with Amy Cell's agency."

St Clair Shores Council Member Chris Vitale

Diversity Results

We have a commitment to having diverse applicant pools, and wanted to share our recent results in this area.

We strive to provide a diverse pool of qualified applicants to our clients. Approximately 47% of recent executive public sector placements have been women and 16% have been people of color including the following searches.

- City of Ann Arbor Attorney
- City of Ann Arbor Chief Financial Officer
- City of Ann Arbor Human Resources Director
- City of Eastpointe City Manager
- City of Fraser City Manager
- City of Fraser Finance Director
- City of Fraser Asst. City Manager
- City of Fraser Asst. Department of Public Works Director
- City of Grand Rapids Economic Development Director
- City of Madison Heights City Manager
- Township of Redford Township Superintendent

References

Please feel free to contact any of the following individuals as references.

215 W. Michigan Ave., Ypsilanti, MI 48197
Phone: 734-657-0370 E-Mail: Amy@AmyCellTalent.com

Client	Project Title Search	Contact Person	Telephone / email
City of Ann Arbor	Director of HR City Administrator, City Attorney Searches	Julie Grand, Former City Council Member	(734) 678-7567 juliegrand@gmail.com
City of Fraser	Recruiting Firm HR Services City Manager Search	Amy Baranski City Council	(586) 293-3100 ext 110 amyb@micityoffraser.com
Scio Township	Township Administrator Finance Director IT Manager HR Manager	Kathy Knol Board Trustee	(734) 369-9400, kknoll@comcast.net , KKnol@sciotownship.org
City of St. Clair Shores	City Manager Search	Chris Vitale, City Council Member	(586) 801-4732 vitalec@scsmi.net
City of Traverse City	City Manager Search	Amy Shamroe, Mayor	(231) 715-1777 ashamroe@traversecitymi.gov
City of Ypsilanti	City Manager Search	Nicole Brown, Mayor	(313) 888-4044 nbrown@cityofypsilanti.com

B. Recruitment Work Plan

To assist the City of Warren in finding candidates for a variety of positions, we will follow our well-honed process. A full description of our approach is included below. We also provide weekly status reports to the hiring representatives.

Step One - Create a Clear Target and Plan

Through a detailed needs assessment, we will learn from you the “must have” and “ideal” experiences and behaviors for the employee. We will start by interviewing stakeholders including the Mayor and Leadership Team, elected officials and staff members to understand the goals, skills, experiences and behaviors that are critical and “ideal” for the position. We will also identify the key selling points of the position, organization and community, which informs the marketing strategy that we create.

Based on stakeholder data, we will create a rubric and align the selection group on experiences, leadership style, communication skills, etc. We will create a comprehensive position profile. We will research the existing compensation and benefits structure as it compares to the market. During this planning meeting we will present the rubric, profile, draft timeline and compensation data to the Mayor and Leadership Team.

Step Two - Market the Posting to the Right People

We use social media and national job boards to promote the opportunity, as well as to promote the amazing aspects of living, working and playing in the City of Warren region. This results in the largest possible pool of qualified applicants. In addition to our proprietary database of executive and professional talent, we will perform targeted outreach to candidates that might not otherwise apply through LinkedIn and other social media platforms, and engage with ICMA Newsletter/Job Center, Michigan Municipal League (MML), and other municipal websites to create a deep, diverse pool of qualified and interested candidates.

Step Three - Thoroughly Assess Applicants

We will thoroughly assess the qualifications and suitability of all candidates in an independent and objective manner. We will use a survey, video interview, phone interview, cyber review, reference checks and background checks to thoroughly assess applicants. We will provide access to and summarize this data for review for the Mayor and Leadership Team. We will coordinate any additional assessments as directed by the Mayor and Leadership Team selection committee.

Step Four - Interviews

We will coordinate an outstanding interview experience for candidates and stakeholders that complies with the Open Meetings Act. Finalists will have a Zoom or on-site interview that can include a wide range of interviews and tours. As directed by the selection committee, we will coordinate schedules, manage candidate communications, and provide on-site logistic support during the on-site interviews. We will thoroughly prepare the selection committee for the interviews by providing guidance, support and interview questions customized to the qualities that emerged through the detailed needs assessment.

Step Five - Negotiation

We will assist with the negotiation process with other administrative and legal parties. Our specific role will be directed by the selection committee.

Step Six - Transition Support

We help candidates successfully transition into their new roles by providing assistance with onboarding and relocation. If desired, we can provide a variety of support to assist with relocation and transition assistance, including housing assistance, partner job search assistance, child and elder care support, and finding local "greeters" to help welcome the new person into the community. We also offer a complimentary 360 degree feedback check-in after six months, and we assist the selection committee with determining performance expectations.

Proposed Timeline

The following timeline details the process (as described above) with a proposed schedule for deliverables and milestones.

Our proposed timeline is further customizable depending on the needs and goals of the City of Warren. It is our goal to create and implement a plan that works well to meet the City’s objectives, recognizing that a flexible approach is often needed as plans unfold.

The detailed timeline below demonstrates how a typical search process flows after we are contracted to begin the search.	
Activity	Time Frame
Stakeholder interviews - We interview stakeholders including the Council, staff, and key community members to understand the goals, skills, experiences and behaviors that are critical and “ideal” for the position. We also learn about the key benefits of the position, organization and community.	Weeks 1, 2
Selection Criteria Matrix - Based on interview feedback and survey data we create a "talent matrix" of key criteria.	Week 3
Marketing plan - Based on the interview feedback and research, we will create a digital and print marketing package that will be used to market the opportunity.	Week 3
Review salary data - Review existing compensation and benefits structure as it compares to market comparables. Present compensation data to the hiring committee at the first meeting and determine target compensation range.	Week 3
Align - We will meet with the selection team to review the hiring criteria and job posting.	Week 4
Market the opportunity - We use social media and national job boards to promote the opportunity, and to promote the amazing aspects of living, working and playing in the community. This results in the largest possible pool of qualified applicants. In addition to our proprietary database of executive and professional talent, we perform targeted outreach through LinkedIn and other social media platforms, and engage with industry associations, which results in a deep, diverse pool of qualified	Weeks 4-8



and interested candidates.	
Assess applicants - We use a survey, video interview, phone interview, cyber review, reference checks and background checks to thoroughly review applicants.	Weeks 4-9
Present candidates - We will provide the selection team with a link to the candidate packets and videos. Selection team members will have approximately one week to review information prior to the meeting to determine finalists.	Week 10
Determine finalists - We will review candidates with the selection team and determine interview panelists.	Week 11
Interviews - We will invite the interviewers, providing them copies of information on the finalist candidates. We also will create sample interview questions and feedback forms.	Week 12
Negotiation & Relocation - We can provide a variety of support regarding contract negotiations, onboarding and developing a 90 day plan. We can provide a six month 360 degree feedback report and coaching session for the new hire to further enhance development and success.	TBD

Key Personnel

Our Team

For this recruitment, we have selected the following team of highly qualified professionals, all of whom are well-versed and experienced in municipal/public sector and executive recruitment. These individuals are based out of our Ypsilanti office.

The table below lists the key persons assigned to this project, as well as their anticipated roles. Resumes are included as an attachment.

Proposed Team Includes:

Name	Title	Anticipated Roles
Amy Cell	President and Founder	Role: Lead. Oversees all search aspects included in this proposal.
Barbie Sigers	Talent Acquisition Director	Role: Manages search activities; participates in meetings; completes stakeholder intake interviews; finalizes the position description. Manages consultants and fine details.
Rebecca Roberts	Senior Associate Consultant	Role: Assists in document production, scheduling and outreach. Assists with candidate screening, background and reference checks. Provides on-site interview support.

Background Checks

We will conduct background checks of shortlisted candidates, using Background Check Central, a highly reputed, Michigan-based firm. Background checks include county criminal records, credit report, state criminal report and if needed, education history and work history.

Background Check Central, 42815 Garfield Road, Suite 208, Clinton Township, MI 48038

Reference Checks

Below are some of the questions asked during the reference check process. We can also include specific questions requested by the Mayor and Leadership Team:

- What is the nature of your relationship with the applicant?
- What duties and responsibilities does/did the applicant have at the time you worked with them?
- What is/was the applicant’s reason for leaving?
- What would you say are the applicant’s strengths?
- What would you say are the applicant’s developmental areas (eg. weaknesses)?
- Have you had any concerns with their performance?
- On a scale from 1-5, how would you rate their: (5 being the best)
 - Overall work performance:

- Communication Skills:
 - Leadership Style & Management Characteristics:
 - Staff Development:
 - Strategic Thinking:
 - Municipal Understanding:
 - Emotional Intelligence & Relationship Orientation:
 - Community Orientation:
 - DEI orientation:
 - Expertise in (One of 5) : The Engineering Unit, The Public Works Unit, The Systems Planning Service Unit, The Wastewater Recovery Unit, The Water Treatment Service Unit.
- Do you think they are capable of performing the job?
 - If you had the chance, would you hire/ work with them again?
 - Do you have any final comments?

C. Costs

Search Components and add-on fees	Level 1	Level 2
Comply with nondiscrimination provisions, established by the EEOC and CCRD	Yes	Yes
Working with the Mayor and Leadership Team to develop characteristics and attributes of the successful candidates, selection criteria, and recruitment process	Yes	Yes
Provide a compensation study of the requested position	Yes	Yes
Developing recruitment strategies and timelines along with targeted recruitment of qualified and experienced individuals	Yes	Yes
Create inviting job posting and post announcement of position	Yes	Yes
Provide initial screening of all applications against the qualifications required in the job description	Yes	Yes
Conduct reference checks and interviews with qualified applicants	Yes	Yes
Select and present the top qualified applicants	Yes	Yes



Report findings and recommend applicants to the City for interviews	Yes	Yes
Developing and coordinating a final selection process with the Mayor, including interviews with Mayor and Leadership Staff	Yes	No
Assist City with compiling interview questions	Yes	No
Conduct full background screening and share results with the City's Human Resources Department.	Yes	Yes
Assist with offer to selected applicant	Yes	No
Providing timely notification and any necessary follow up and feedback to all candidates not selected for the position	Yes	Yes
Write press release announcing finalists (\$500 additional fee outside of Level 1)	Yes	No
Host community reception, gather and analyze feedback (\$1000 additional fee for Level 2)	Yes	No
Develop recruitment brochure (\$500 additional fee outside for Level 2)	Yes	No
360 degree feedback for new hire (\$500 additional fee for Level 2)	Yes	No
Guarantee*	One year	None
Total Cost	\$18,500	\$4,950

Note: Reception food costs, interview food costs, and candidate travel costs are not included above.

Price Clause

The prices will be held for 90 days or until bid award, whichever comes first, except for the successful bidder whose prices shall be held firm the entire contract period, which shall be from a one (1) year period with options to extend for four (4) additional one (1) year periods, with mutual consent of both parties.

Placement Guarantee Terms

In the event the new employee rescinds their acceptance of the job offer, voluntarily leaves employment within one year of their start date or is fired for cause, we will waive our base recruiting fee and conduct one additional search for the cost of direct marketing, travel and third party fees.

Payment Terms

We will invoice one half of the fee upon contract signing to cover advertising and administrative costs. Another payment of one half of the total fee will be invoiced upon the presentation of a slate of finalist candidates. Net 45 day terms kindly requested.

Thank you again for the opportunity to submit this proposal to assist the City of Warren in its pursuit for a qualified, experienced, professional recruitment services firm.

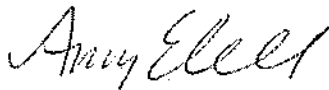

Amy Cell
President, Amy Cell, LLC
734-657-0370
Amy@AmyCellTalent.com

D. Attachments

The remainder of this page is intentionally left blank.

ATTACHMENT I - Non-Iran Linked Business Confirmation

**IRAN ECONOMIC SANCTIONS ACT
Michigan Public Act No. 517 of 2012**

The undersigned, the owner or authorized officer of Amy Cell, LLC, pursuant to the compliance certification requirement provided in the hereby certifies, represents and warrants that the Bidder (including its officers, directors and employees) is not an Iran linked business within the meaning of the Iran Economic Sanctions Act, and that in the event the Bidder is awarded a contract as a result of the aforementioned Request for Proposal, the Bidder will not become Iran linked business at any time during the course of performing the work or any services under the contract.

Specifically, the undersigned, owner or authorized officer of Amy Cell, LLC attests it does not fall within the following definition of the Iran Economic Sanctions Act:

MCL 129.312 (e) of the Act provides: (e) "Iran linked business" means either of the following:

(i) A person [as defined below by MCL 129.312(f)] engaging in investment activities in the energy sector of Iran, including a person that provides oil or liquefied natural gas tankers or products used to construct or maintain pipelines used to transport oil or liquefied natural gas for the energy sector of Iran. (ii) A financial institution that extends credit to another person, if that person will use the credit to engage in investment activities in the energy sector of Iran.

(f) "Person" means any of the following:

(i) An individual, corporation, company, limited liability company, business association, partnership, society, trust, or any other nongovernmental entity, organization, or group. (ii) Any governmental entity or instrumentality of a government, including a multilateral development institution, as defined in section 1701(c)(3) of the international financial institutional act, 22 USC 262(c)(3).



Amy Cell

President

Amy Cell, LLC



ATTACHMENT II - Certification of Insurance

The remainder of this page is intentionally left blank.



CERTIFICATE OF LIABILITY INSURANCE

DATE (MM/DD/YYYY)
3/4/2024

THIS CERTIFICATE IS ISSUED AS A MATTER OF INFORMATION ONLY AND CONFERS NO RIGHTS UPON THE CERTIFICATE HOLDER. THIS CERTIFICATE DOES NOT AFFIRMATIVELY OR NEGATIVELY AMEND, EXTEND OR ALTER THE COVERAGE AFFORDED BY THE POLICIES BELOW. THIS CERTIFICATE OF INSURANCE DOES NOT CONSTITUTE A CONTRACT BETWEEN THE ISSUING INSURER(S), AUTHORIZED REPRESENTATIVE OR PRODUCER, AND THE CERTIFICATE HOLDER.

IMPORTANT: If the certificate holder is an ADDITIONAL INSURED, the policy(ies) must have ADDITIONAL INSURED provisions or be endorsed. If SUBROGATION IS WAIVED, subject to the terms and conditions of the policy, certain policies may require an endorsement. A statement on this certificate does not confer rights to the certificate holder in lieu of such endorsement(s).

PRODUCER Kapnick Insurance Group 333 Industrial Dr Adrian MI 49221	CONTACT NAME: Alyssa Roelofs PHONE (A/C, No, Ext): 734-929-6053 E-MAIL ADDRESS: alyssa.roelofs@kapnick.com	FAX (A/C, No): 517-263-6658
	INSURER(S) AFFORDING COVERAGE	
	INSURER A: Continental Casualty Company	NAIC# 20443
INSURED Amy Cell, LLC 215 W. Michigan Avenue Ypsilanti MI 48197	INSURER B: Berkley Regional Insurance Company	NAIC# 29580
	INSURER C:	
	INSURER D:	
	INSURER E:	
	INSURER F:	

COVERAGES CERTIFICATE NUMBER: 573037635 REVISION NUMBER:

THIS IS TO CERTIFY THAT THE POLICIES OF INSURANCE LISTED BELOW HAVE BEEN ISSUED TO THE INSURED NAMED ABOVE FOR THE POLICY PERIOD INDICATED. NOTWITHSTANDING ANY REQUIREMENT, TERM OR CONDITION OF ANY CONTRACT OR OTHER DOCUMENT WITH RESPECT TO WHICH THIS CERTIFICATE MAY BE ISSUED OR MAY PERTAIN, THE INSURANCE AFFORDED BY THE POLICIES DESCRIBED HEREIN IS SUBJECT TO ALL THE TERMS, EXCLUSIONS AND CONDITIONS OF SUCH POLICIES. LIMITS SHOWN MAY HAVE BEEN REDUCED BY PAID CLAIMS.

INSR LTR	TYPE OF INSURANCE	ADDL INSD	SUBR WVD	POLICY NUMBER	POLICY EFF (MM/DD/YYYY)	POLICY EXP (MM/DD/YYYY)	LIMITS
A	<input checked="" type="checkbox"/> COMMERCIAL GENERAL LIABILITY <input type="checkbox"/> CLAIMS-MADE <input checked="" type="checkbox"/> OCCUR GEN'L AGGREGATE LIMIT APPLIES PER: <input checked="" type="checkbox"/> POLICY <input type="checkbox"/> PRO-JECT <input type="checkbox"/> LOC OTHER:	Y	Y	7038497008	8/9/2023	8/9/2024	EACH OCCURRENCE \$ 2,000,000 DAMAGE TO RENTED PREMISES (Ea occurrence) \$ 1,000,000 MED EXP (Any one person) \$ 10,000 PERSONAL & ADV INJURY \$ 2,000,000 GENERAL AGGREGATE \$ 4,000,000 PRODUCTS - COM/POP AGG \$ 4,000,000 \$
A	<input type="checkbox"/> AUTOMOBILE LIABILITY <input type="checkbox"/> ANY AUTO <input type="checkbox"/> OWNED AUTOS ONLY <input checked="" type="checkbox"/> HIRED AUTOS ONLY <input type="checkbox"/> SCHEDULED AUTOS <input checked="" type="checkbox"/> NON-OWNED AUTOS ONLY	Y	Y	7038497008	8/9/2023	8/9/2024	COMBINED SINGLE LIMIT (Ea accident) \$ 1,000,000 BODILY INJURY (Per person) \$ BODILY INJURY (Per accident) \$ PROPERTY DAMAGE (Per accident) \$ \$
A	<input checked="" type="checkbox"/> UMBRELLA LIAB <input checked="" type="checkbox"/> OCCUR <input type="checkbox"/> EXCESS LIAB <input type="checkbox"/> CLAIMS-MADE <input checked="" type="checkbox"/> DED <input checked="" type="checkbox"/> RETENTION \$ 10,000	Y	Y	7038497011	8/9/2023	8/9/2024	EACH OCCURRENCE \$ 2,000,000 AGGREGATE \$ 2,000,000 \$ <input type="checkbox"/> PER STATE <input type="checkbox"/> OTH-ER
	WORKERS COMPENSATION AND EMPLOYERS' LIABILITY ANY PROPRIETOR/PARTNER/EXECUTIVE OFFICER/MEMBER EXCLUDED? (Mandatory in NH) If yes, describe under DESCRIPTION OF OPERATIONS below	Y/N	N/A				<input type="checkbox"/> E.L. EACH ACCIDENT \$ <input type="checkbox"/> E.L. DISEASE - EA EMPLOYEE \$ <input type="checkbox"/> E.L. DISEASE - POLICY LIMIT \$
A	Professional Liability			652423164	4/1/2024	4/1/2025	Each Claim 1,000,000
A	Employment Practices Liability			652423184	4/1/2024	4/1/2025	Aggregate Limit 1,000,000
B				BMP-1021131-00	8/9/2023	8/9/2024	Aggregate Limit 1,000,000

DESCRIPTION OF OPERATIONS / LOCATIONS / VEHICLES (ACORD 101, Additional Remarks Schedule, may be attached if more space is required)

CERTIFICATE HOLDER Verification Of Coverage United States	CANCELLATION SHOULD ANY OF THE ABOVE DESCRIBED POLICIES BE CANCELLED BEFORE THE EXPIRATION DATE THEREOF, NOTICE WILL BE DELIVERED IN ACCORDANCE WITH THE POLICY PROVISIONS. AUTHORIZED REPRESENTATIVE <i>James A. Kapnick</i>
--	---

© 1988-2015 ACORD CORPORATION. All rights reserved.



ATTACHMENT III - Addendums 1 and 2

The remainder of this page is intentionally left blank.

Lori M. Stone, Mayor



Purchasing Division
Office of the Controller
One City Square, 4th Floor
Warren, Michigan 48093-6289

Phone (586) 574-4639
FAX (586) 574-4614

ADDENDUM 1

APRIL 12, 2024

ITB-W-1195

**REGARDING
FURNISH RECRUITING SERVICES**

PLEASE ALSO BE ADVISED OF THE FOLLOWING RESPONSES TO VENDOR QUESTIONS:

- Q1. Regarding the length of the open positions – Are they contract (or short term), contract with the possibility of being hired direct, or direct hire?
- R1. The positions will be for Full-time appointments of select non-Civil Service positions. The City holds discretion as to what positions the awarded agency will be recruiting.
Per recruitment - City reserves the right to assign what positions are to be recruited. It will not be a blanket of all City positions.
- Q2. Regarding the "Per Event Fee" – Should this reflect a percentage of the annual salary?
- R2. The City is seeking a Per Event Fee for Level 1 and Level 2 Recruitment Services. The assumption is that it will be a firm flat fee per event.
- Q3. What are the job classifications for these openings?
- R3. Select non-Civil Service positions.
- Q4. Will the awarded Vendor be placing drivers?
- R4. These positions require the applicant's driving record to meet City Standards for insurability.
- Q5. How many openings do you currently have?
- R5. Some with possible future recruitments being necessary.

BIDDERS ARE REMINDED:

Additional information regarding this bid or any questions can be answered by contacting Craig Treppa, Purchasing Agent, via email at ctreppa@cityofwarren.org, Subject ITB-W-1195.

Sincerely,

A handwritten signature in black ink, appearing to read "CT", written over a horizontal line.

Craig Treppa
Purchasing Agent

Acknowledged by Mari Kisch

Company Name Amy Cell, LLC

Lori M. Stone, Mayor



Purchasing Division
Office of the Controller
One City Square, 4th Floor
Warren, Michigan 48093-5289

Phone (586) 574-4639
FAX (586) 574-4614

ADDENDUM 2

APRIL 19, 2024

ITB-W-1195

REGARDING

FURNISH RECRUITING SERVICES

PLEASE BE ADVISED OF THE FOLLOWING RESPONSES TO VENDOR QUESTIONS:

- Q1. Can you be more specific to the type of non-civic positions, i.e., Clerical, administrative, janitorial, professional, technical?
R1. These positions are for Directors (Dept Heads) of various Departments within the City.
- Q2. Are we to assume the positions including drivers will not be contract workers?
R2. Correct. There are no positions for drivers. The position will require driving to/from work and to meetings, etc.
- Q4. For the Level 1 Recruitment Scope of Work, what type of positions will fall under this level?
R4. Level 1 is for the Recruitment of a Public Safety Position (i.e. Police Commissioner).
- Q5. For the Level 2 Recruitment Scope of Work, what type of positions will fall under this level?
R5. These positions are for Directors (Dept Heads) of various Departments within the City.
- Q6. Are you looking for direct hire type of positions and/or contract/temp to hire positions?
R6. The City is planning on hiring the candidates direct.
- Q7. Under the pricing section, it states "per event fee," that defines per position we work on, correct?
R7. Yes. The "per event fee" is per position requested by the City for Recruitment.
- Q8. What is the employee classification rate?
R8. This services requires a compensation study for the requested positions.
- Q9. Is the City looking for temporary staffing services?
R9. No
- Q10. Is the City looking to fulfill I.S. positions with this contract or is it a wide range of positions?
R10. There is a wide range of positions.
- Q11. Could the City please clarify if the registration for NIGP codes is mandatory for all prime vendors?
R11. Bids must be obtained and submitted via the BidNet (MITN) system by registering on the BidNet (MITN) system. Go to www.BidNetDirect.com/MITN, 2) Click on "Register Now", 3)

Activate your account & select your registration option. Call 800-835-4603 and press option two (2) to speak live with customer support. If needed, ask for assistance on being set up utilizing the Free Registration Option.

Q12. Could the City please clarify if the register for NIGP codes is mandatory for all subcontractors?

R12. Bidders are to list any subcontracting vendors in their bid response.

Q13. Could the City kindly confirm if NIGP codes are a necessary requirement to bid?

R13. NIGP codes are necessary to be able to bid on the BidNet (MITN) system.

Q14. Could the City please clarify if vendors and/or subcontractors must have all of the NIGP codes in order to bid?

R14. See R13.

Q15. Could the City please clarify if firms are allowed to meet the minimum requirements through subcontractors?

R15. This question can only be answered after review of submitted bids, and the work to be provided by the subcontractor(s), if any.

Q16. Is this a new initiative? If not, could the City please provide the incumbent information?

R16. This is a new initiative.

Q17. Could the City kindly clarify if vendors are required to turn in the ITB document signed by an authorized representative at the end of each of the sheets? If so, where should vendors attach the signed ITB document?

R17. The City requires that the bidder sign Page 3 of the bid form. The City requests that the bidder sign all clauses, and general conditions. Bidders are to sign all addendum, as well.

Q18. Are firms required to pay Holidays, PTO, Sick Leaves, etc., to the consultants placed?

R18. Candidates will be direct hires by the City.

Q19. Can firms provide commercial references?

R19 See Page 6 of the bid form.

Q20. Can firms provide references from ongoing contracts?

R20. Yes

Q21. Could the City please confirm if vendors must have experience recruiting C-Suite candidates?

R21. Yes, they must have experience recruiting C-Suite candidates for Level 1 award.

Q22. Is there a specific format for the proposal response (font size, font type, spacing, etc.)?

R22. Bidders are to submit bid form, addenda, and answers to the questions provided in the bid form. The questions and answers can be attached as a separate document. There is no specific format for the bidder's answers to questions.

Q23. Could the City please elaborate on the preferences for technical responses such as formatting and document/attachment placement?

R23. See R22.

Q24. Could the City kindly confirm the list of documents that should be presented as attachments? Where should these attachments be placed?

R24. See R22. These can be placed as separate bid documents or combined at the end of the ITB-W-1195 bid document.

Q25. Could the City kindly confirm where in the technical response should the section called "QUESTIONNAIRE" must be attached?

R25. See R24.

Q26. Could the City please share the evaluation criteria?

R26. No

Q27. Could the City please clarify if local agencies will be preferred?

R27. The City will review all bids prior to making an award and will award to the firm that the City feels is the best for the City.

Q28. Could the City kindly confirm if vendors must bid under all categories in order to be considered for award?

R28. The bidder does not have to bid under all categories to be considered for award.

Q29. Could the City kindly share the positions to be hired in this contract?

R29. See R4. and R5.

Q30. Under section QUESTIONNAIRE, point 7, it states: "Are you able to meet the insurance requirements (please include a copy of a current insurance certificate)?" Could the City kindly clarify if this document should be presented as attachment? If so, where should it be placed?

R30. Bidder shall indicate whether it can meet insurance requirements on Page 7 of the bid form. If being recommended for award, the bidder must present the proper insurance certificate before an award is made. If submitting your firm's insurance certificate with your bid, it can be added as a separate document or can be included with your submitted bid document.

Q31. Under section QUESTIONNAIRE, point 4, it states: "Where is the location of the office(s) from which the work on this engagement(s) is to be performed?" Could the City please confirm if the positions being sought are to be performed on site or could candidates work remotely?

R31. The City is asking where your main office will be that the work is being directed from. Work is not to be done on-site. However, meetings will take place to allow the awarded firm to obtain a clear understanding of the position(s) to be filled.

Q32. Could the City kindly share the allocated budget for this contract?

R32. No

Q33. Is the City looking for the recruitment of direct hire positions?

R33. See R6.

Q34. If a firm has experience in providing temporary staffing services but not direct hire experience can they bid on this solicitation?

R34. The City is not seeking temporary staffing positions. If your firm believes it can fulfill the requirements of the bid then your firm should submit a bid.

Q35. How are firms expected to answer the Questionnaire section? Are separate attachments allowed?

R35 See R22.

Q36. Does the Questionnaire section need to be included within the 18 page ITB document or as a separate attachment?

R36. Either is acceptable.

Q37. Under the Special Instructions for Electronic Bid Submission it states "The bidder shall complete the bid form in its entirety, sign Page 3 and all other appropriate areas (clauses, etc.), scan the document, and upload the completed document (pages 1-18) with your electronic bid submission." Could the City please clarify if the bid form is the entire electronic bid or is there anything else needed apart from the 18 page document?

R37. Bidders are to submit 18-page document, addenda, answers to questions. See R22.

Q38. Could the City please confirm if by submitting the 18 page bid form document is sufficient for a responsive bid?

R38. See R22. and R37.

Q39. Could the City please confirm if the Questionnaire section is the only technical document firms need to address in order to be a responsive bidder?

R39. See R22. and R37.

Q40. For the pricing, can firms provide a percentage based on the candidates annual salary?

R40 See R2. of Addendum #1.

Q41. For the pricing, is the City looking for firms to provide a flat fee for all the tasks involved in each level?

R41 See R2. of Addendum #1.

Q42. Question 14 in the Questionnaire states "Please provide a sample of your proposed contract, if applicable." Could the City please clarify what is meant by proposed contract? Is it referring to the proposed contract to candidates?

R42. The City will require the awarded firm to enter into a contract with the City. If the firm has a standard contract that they utilized then it should be included with the firm's bid.

- Q43. Question 6 in the Questionnaire states "Is your agency an Equal Opportunity Employer?" Will a statement suffice this point or do firms need to provide something else in order to suffice this requirement?
- R43. Statement is suffice.
- Q44. Do firms need to address the mandatory requirements? If yes, where should firms address these points?
- R44. No. The City will verify.
- Q45. Are electronic signatures allowed?
- R45. Yes
- Q46. Could the City please grant an extension on the due date?
- R46. No. An extension will not be allowed at this time.
- Q47. Could the City please confirm the information vendors should add in the warranty line on page 3?
- R47. The bid form clearly states "Warranty (if Applicable)
- Q48. Are there scores for the evaluation criteria?
- R48. Evaluation criteria will not be shared at this time.
- Q49. Does the City accept remote resources to work on this engagement?
- R49. Work by the awarded firm can be done off-site. However, panel interviews are preferred on-site.
- Q50. Does the City accept offshore resources to work on this engagement?
- R50. No
- Q51. Does the City prefer on-site resources to execute this engagement?
- R51. The City will accept execution of agreements both off-site and on-site.
- Q52. Could the City please clarify how many vendors will be awarded?
- R52. See Award Clause on Page 9 of the bid form.
- Q53. Could the City kindly provide information regarding the anticipated form in which task orders will be released, specifying whether it will be through email, portal, or any other designated method?
- R53. The City will, most likely, issue a Purchase Order for the position(s) to be recruited.
- Q54. What would be the number of awards you intend to give (approximate number)?
- R54. Multiple
- Q57. What is the tentative start date of this engagement?
- R57. The City is planning to make an award as soon as possible.
- Q60. Are there any pain points or issues with the current vendor(s)?
- R60. Not Applicable.

Q61. Could you please share the previous spending on this contract, if any?

R61. Not Applicable

Q62. Is there any mandatory subcontracting requirement for this contract? If yes, Is there any specific goal for the subcontracting?

R62. No

Q63. How many positions were used in the previous contract?

R63. Not Applicable

Q65. If the proposed candidates are not available at the time of award, will the agency allow us to provide replacement personnel with similar or more skill sets?

R65. See Scope of Services in the bid form.

Q66. Are resumes required at the time of proposal submission? If yes, Do we need to submit the actual resumes for proposed candidates or can we submit the sample resumes?

R66. See Scope of Services in the bid form.

Q67. Could you please provide the list of holidays?

R67. This will be discussed during Level 1 and Level 2 recruitment services.

Q68. Are there any mandated Paid Time Off, Vacation, etc.?

R68. See R67.

BIDDERS ARE REMINDED:

Additional information regarding this bid or any questions can be answered by contacting Craig Treppa, Purchasing Agent, via email at ctreppa@cityofwarren.org, Subject ITB-W-1195.

Sincerely,



Craig Treppa
Purchasing Agent

Acknowledged by Mari Kisch

Company Name Amy Cell, LLC

ATTACHMENT IV - Team Resumes

Amy Cell

Barbie Sigers

Rebecca Roberts

The remainder of this page is intentionally left blank.

AMY CELL

734-657-0370

Amy@AmyCellTalent.com

SUMMARY

Dynamic leader passionate about talent attraction, retention and development who has used her creativity, team building skills and expertise to create and launch statewide talent programs and support Michigan communities, companies and people.

EXPERIENCE

AMY CELL, LLC, Ypsilanti, MI

President, 3/2015 - Present

Amy Cell Talent is a talent consultancy that provides a variety of talent acquisition, community development and job seeker support programs to clients. We are a team of skilled and dedicated professionals based in Ypsilanti Michigan.

- Provide efficient and effective talent acquisition services to Michigan technology companies - completed over 600 searches that span executive, administrative, and technical opportunities.
- Provide career development services to job seekers and people in career transitions.
- Supported Community Ventures, a program that provides a career pathway out of poverty.
- Launched a talent program for University technology transfer organizations.
- Frequent speaker, advisor, facilitator, panelist and judge. Engagements have included the Brookings Institution and Edward Lowe Foundation.
- Faculty member, Center for Entrepreneurship, U-Michigan College of Engineering.

MICHIGAN ECONOMIC DEVELOPMENT CORPORATION, Lansing, MI

Senior Vice-President, Talent Enhancement, 1/2011 - 3/2015

MEDC is the state economic development organization. Joined MEDC with the Gov. Snyder administration to develop a Talent function housed within economic development.

- Led the redesign of the state labor exchange and talent marketing strategy. Website average 80K postings per month and 200K active account holders. Approximately 3 million unique users per year. Social media strategy includes newsletters, Twitter, Facebook and LinkedIn.
- Created and launched Community Ventures in 2012, which has placed 4000 structurally unemployed into living wage jobs with a \$11.20 average wage and 68% one year retention rate.
- Launched the Michigan Advanced Technician Training program, a dual education program based on the German apprenticeship model. Program is viewed as a national model and was featured by the Brookings Institute on a German study tour. Program has been adopted by Illinois, and many other states have requested additional information.

- Designed and directed programs to attract and retain highly educated talent, including LiveWorkDetroit, Dream Job, Pure Michigan Opportunity and a college ambassador program. Results included thousands of IT and Engineering student connections to employers.
- Participated on a select task force to determine strategy to propel Michigan to a top 10 state in terms of adults with a post-secondary credential or higher.
- Launched the Community College Skilled Trades Equipment Program - a \$50 million bond initiative to provide community colleges with critical training equipment.
- Launched Global Michigan, an initiative to embrace, attract and retain international talent. Built a team from one staff person to 30. Team had one of the highest employee engagement levels in the state government per a survey managed by PricewaterhouseCoopers.
- Accomplished and well-regarded speaker and presenter with approximately 50 engagements as panelist, moderator or key note presenter.

ANN ARBOR SPARK, Ann Arbor, MI

Vice-President, Talent Enhancement & Entrepreneurial Education, 8/2006 - 1/2011

Ann Arbor SPARK is a non-profit regional economic development organization driving local and statewide economic development initiatives. Key responsibilities included the creation and management of all Talent Enhancement programs, directing all Entrepreneur Education programs and overseeing the SPARK East incubator.

- Positioned SPARK to be a "talent hub" for knowledge-based workers seeking dynamic opportunities through events, job posting service and weekly newsletters. Posted approximately 1000 jobs for 400 companies annually, saving thousands of dollars per hire.
- Created programming to support SPARK East, a successful incubator in a challenged area and have had two companies graduate from the program in the first 18 months.
- Developed and launched numerous entrepreneur education programs including the one-day "Starting Your Own Business" program, Michigan Energy Forum, Entrepreneur Education 1.0 and 2.0 series, Expert Resource Board, Power Lunch and SPARK East Speaker Series.
- Co-developed Shifting Gears, a 4-month developmental program to help displaced "large company" managerial talent transition into "new economy" opportunities. Program later was expanded by the Michigan Economic Development Corporation and helped approximately 400 highly educated, accomplished, later-career people transition to new opportunities.

ROSS SCHOOL OF BUSINESS AT U-MICHIGAN, Ann Arbor, MI

Senior Associate Director, Office of Student Life, 9/2004 - 7/2006

- Created and led the Office of Student Life. Developed policies/processes to support students, including leadership programming, diversity, training, recognition, and student relations.
- Championed school-wide leadership development efforts and programs.
- Created culturally sensitive environment through programming and addressing problems.
- Resolved scores of student relations concerns and community issues.

APPLIED BIOSYSTEMS, Foster City, CA

Senior Manager, Human Resources, 11/2003 - 6/2004

- Led the restructuring and reengineering of IT department. Results included more efficient structure, employee development and redeployment of managers to better utilize talent.
- Launched development councils to coordinate succession planning and employee development.
- Provided organizational effectiveness tools such as leadership development and coaching, training, 360-degree feedback, change management and facilitated new leader assimilations.

HR DRIVERS, Los Altos, CA

Managing Partner, 9/2002 - 10/2003

- Founded HR Consulting Partnership that provides HR consulting, training and outsourcing services to small businesses that want innovative and strategic HR programs and processes.
- Developed extensive HR audit program to thoroughly review each element of HR, to ensure that all legal issues and best practices are considered.

SRI CONSULTING, Menlo Park, CA

HR Manager, 2001 - 2001

- Reported to CFO of SRI International and directed all HR activities for SRI Consulting that resulted in cost savings, strategic leadership change and benefit and compliance improvements.
- Developed new processes for recruiting, merit planning, orientation, mentoring, leadership development/succession planning, performance management and visa management.

FORD MOTOR COMPANY, Dearborn, MI

HR Roles Including Labor Rep, Associate and Analyst, 1995 - 2001

- Provided counsel to business units in employee relations, performance management, diversity, staffing, compensation, job leveling/ranking, succession planning and work/life issues.
- Analyzed U.S. recruiting process; recommended switching to Resumix with an ROI of 40%.
- Participated on team, which integrated Global affiliate manufacturing operations.

PLANTE & MORAN, CPA's, Ann Arbor, MI

Certified Public Accountant, 1990 - 1993

- Passed CPA exam in first sitting.
- Planned, executed, supervised and managed audit and tax engagements.

EDUCATION

THE UNIVERSITY OF MICHIGAN, Ann Arbor, MI

MBA - Ross School of Business Administration, 1993 - 1995

- with High Distinction (Top 10%)

BBA - Ross School of Business Administration, 1987 - 1991

BOARD MEMBERSHIPS

Board & Community Involvement: Michigan Center for Integrative Research in Critical Care, Career Education Advisory Committee, Desai Accelerator, Washtenaw Community College Foundation, Center for Entrepreneurship (CFE) - U-M College of Engineering, Washtenaw Community College Women's Council, Women's Exchange of Washtenaw, U-M SE Michigan Alumni Association, Washtenaw 2030 Steering Committee

The remainder of this page is intentionally left blank.



BARBIE SIGERS

Ann Arbor, MI • 517-230-9911

barbie@amycelltalent.com • [linkedin.com/in/barbie-sigers-916769b](https://www.linkedin.com/in/barbie-sigers-916769b)

SUMMARY Energetic, detail- and results-oriented professional with over twenty years of experience in human resources, pharmaceutical sales and health / fitness training and management.

EXPERIENCE

- AMY CELL, LLC** Ypsilanti, MI 2021-present
Talent Acquisition Director
- Build client relationships and manage recruitment lifecycle from engagement through closure.
 - Recruit for hard to fill, newly created, and specialized positions ranging from entry level personnel to C-suite executives.
 - Strategic sourcing, screening, evaluating and presenting of candidates to hiring managers.
 - Review job postings to ensure accuracy and completeness. Update job posting language as necessary, to capture the attention of target audiences.
 - Design and process job specific questionnaires to understand candidate's work styles, motivation, personality, and other information that cannot be determined from a resume.
- Burn Bootcamp**, Northville, MI 2020 – 2021
Personal Trainer/Group Fitness Instructor
- Designed and coached over 500 training classes.
 - Conducted 1-on-1 coaching sessions with clientele to understand motivators and limitations, improve self-confidence and develop nutrition and training plans.
- Red Effect Infrared Fitness**, Ann Arbor, MI 2018 – 2020
Lead Trainer
- Developed and coached over 800 high intensity interval training classes.
 - Sourced, screened, interviewed and trained new instructors.
 - Integral role in the startup of the facility and building client base.
- CentraState Fitness & Wellness Center**, Freehold, NJ 2014-2018
Personal Trainer / Group Fitness Instructor / Pilates Instructor
- Conducted fitness assessments & goal planning for members.
 - Developed & customized 1-on-1 fitness plans for 25 long term clients.
 - Lead trainer in medically based programming, sports performance training, weight loss, and improvement of overall physical health.
 - Designed & implemented customized individual & group pilates classes.
 - Instructed 8 group training classes per week.
- Esprit Pharma**, Detroit, MI 2006 --2007
Urology/Gynecology Sales Specialist
- Launched new products to urologists, surgeons, and obstetrician-gynecologists.
 - Planned medical education programs to improve sales and build strong rapport with key decision-makers.
- Wyeth Pharmaceuticals**, Grand Rapids, MI 2001 – 2005
Territory Representative
-



- District Rep of the Year and Rookie of the Year.
- Territory analysis, business development & project management to increase product sales.
- Marketed products to cardiologists, neurologists, gastroenterologists, diabetic educators, pharmacists, and internal medicine and family practitioners through presentations, in-services, and education events.

Nelson Professional Sales, Lansing, MI

2000 – 2001

Territory Representative

- Developed and executed business and marketing plan for territory to exceed sales goals.
- Marketed cardiovascular products to cardiologists, internists, and family practitioners.

SmithKline Beecham Pharmaceuticals, Lansing, MI

1998-2000

Sales Consultant

- Ranked #1 in district for three consecutive quarters and #7 in the region of over 200 sales consultants for top product, Augmentin.
- Successfully launched a new product, achieving 64% over sales goal.
- Marketed a wide range of physicians in clinics & hospitals; Conducted in-service's & journal club meetings.

Robert Half International, Okemos, MI

1995-1998

Division Director

- Built a Fortune 500 client base and worked with clients to fill critical executive staffing needs.
- Sourced, screened, evaluated & presented applicants to hiring managers.
- Managed and operated a matrix of skilled candidates for future placements.
- Marketed services and candidate pool based on market trends and business needs; B2B relationship/ account management.

EDUCATION

Eastern Michigan University, Ypsilanti, MI

Bachelor of Business Administration in Human Resource Management

Keller Graduate School of Management, DeVry University

Completed coursework toward Master of Human Resource Management (12 credits)

OTHER SKILLS

Microsoft Office (Word, Excel, PowerPoint and Outlook); Google Productivity Tools, JazzHR, Rippling, Zoho, Zoom



Rebecca Roberts

Kalamazoo, MI, 49009 • 269-447-8676

rebecca@amyceelltalent.com • [linkedin.com/in/rebecca-roberts-0538201a3/](https://www.linkedin.com/in/rebecca-roberts-0538201a3/)

Human Resource Consulting | Recruitment | Training Design | Performance Management | Employee Engagement |
Organizational Development | AR Functions | Inventory Management | Supplier Relations |

WORK EXPERIENCE

AMY CELL, LLC, Ypsilanti, MI

Senior Associate Consultant, 8/2021 - Present

- Restructure performance evaluation forms and process to impact client's non-profit, healthcare organization.
- Develop organizational charts and SOP's for internal usage
- Management of different jobs postings and responsible for posting jobs on multiple platforms in a timely manner
- Produce HR Assessment with recommendations on organizational improvements by analyzing client documents and offer projects to support these recommendations
- Facilitate employee conversations and manage engagement activities to support a series of DEI workshops for 20 employees in a client's organization
- Facilitate full-cycle recruitment services for all level positions in multiple industries

VANDE BUNTE EGGS, Otsego, MI

Business Analyst Internship, 1/2021 - 12/2020

- Conduct supplier analysis to ensure cost effectiveness of production materials
- Manage existing supplier relationships and establish new contacts for cost saving opportunities
- Inventory management, reporting, and purchasing for three facilities
- Establish and maintain spreadsheet and documentation for capital projects and future developments
- CFS inventory management and general IT onsite contact and liaison for third party IT company
- I-9 audit preparation and employee file review

Office Manager, 12/2017 - 5/2021

- General office administration: answering phones, greeting visitors, incoming and outgoing mail administration, updating and creating spreadsheets, scanning invoices, buying equipment
- Supporting HR functions: new hire paperwork and system setup, validation of employee documentation, assist employees with form interpretation, and digitalization of all employee files
- Responsible for AR functions including creating invoices, intracompany transfers, verifying accuracy of orders, and monthly reporting of sales to American Egg Board
- Weekly and monthly reporting of production activity and quality comparison to industry standards and historical data
- Sourced and implemented uniform system for all processing and production employees at two facilities
- Representing the company at food shows in a professional manner
- Miscellaneous duties assigned by management

Accounting Assistant, 11/2016 - 7/2017

- Established system for organization and digitalization of all capital asset files
- Archived accounting records in compliance with retention standards

EDUCATION

GRAND VALLEY STATE UNIVERSITY, Grand Rapids, MI

Bachelors of Arts, Business Administration

215 W. Michigan Ave., Ypsilanti, MI 48197
Phone: 734-657-0370 E-Mail: Amy@AmyCellTalent.com

End of Item 14